









CONTRACTOR:  	300 KT POLYETHYLENE PLANT ARYA SASOL POLYMER COMPANY (ASPC)	OWNER:  شرکت پلیمیر آریا ساسول ARYA SASOL POLYMER COMPANY پارس، تهران																				
VENDOR LOGO: 	GA DRAWING FOR CONVEYING AIR COMPRESSOR WITH DETAILS, PART LIST (44C-80005A~C)	MC:  شرکت مهندسی ايسدكو گروه مهندسی سازه و سازه های صنعتی																				
Owner Document Number :	<table border="1"> <tr> <th>OWNER Project No.</th> <th>Vendor DOC.</th> <th>MR No.</th> <th>Vendor Code</th> <th>Discipline</th> <th>Unit</th> <th>Type</th> <th>Seq. No</th> <th>Rev.:</th> <th>Page</th> </tr> <tr> <td>3944</td> <td>VD</td> <td>0180</td> <td>DYP</td> <td>RE</td> <td>800</td> <td>DWG</td> <td>0032</td> <td>00</td> <td>1 of 3</td> </tr> </table>	OWNER Project No.	Vendor DOC.	MR No.	Vendor Code	Discipline	Unit	Type	Seq. No	Rev.:	Page	3944	VD	0180	DYP	RE	800	DWG	0032	00	1 of 3	
OWNER Project No.	Vendor DOC.	MR No.	Vendor Code	Discipline	Unit	Type	Seq. No	Rev.:	Page													
3944	VD	0180	DYP	RE	800	DWG	0032	00	1 of 3													

GA DRAWING FOR CONVEYING AIR COMPRESSOR WITH DETAILS, PART LIST (44C-80005A~C)

Change the information in this field

P.O. No.:	SHAU23-006-DYPNF-ASS	RESULT CODE : <input type="checkbox"/> AP <input type="checkbox"/> AN <input type="checkbox"/> CO <input type="checkbox"/> RE
MR. No.:	3944-SZP-RE-400-MRQ-0171	NEXT STATUS : <input type="checkbox"/> IFI <input type="checkbox"/> IFA <input type="checkbox"/> AFC <input type="checkbox"/> ASB or FIN
Item No. (Equipment No.):	POWDER CONVEYING SYSTEM(W-40001)	RESUBMISSION DATE :
Vendor Job No.:	PC2312	Approval or review hereunder shall not be considered to relieve Vendor/ Subcontractor of his responsibilities and liability under the Contract.

00	19.May,2025	Issue for Approval	S.Y Lee 	M.J Park 	M.H Yim 	
Rev.	Date	Purpose of Issue	Prepared	Checked	Approved	AC Code

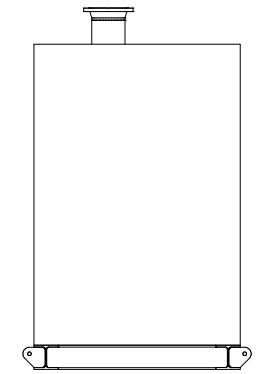
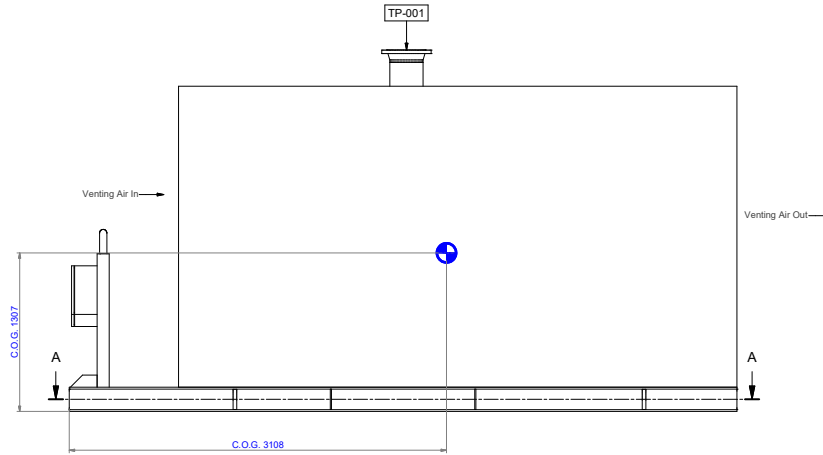
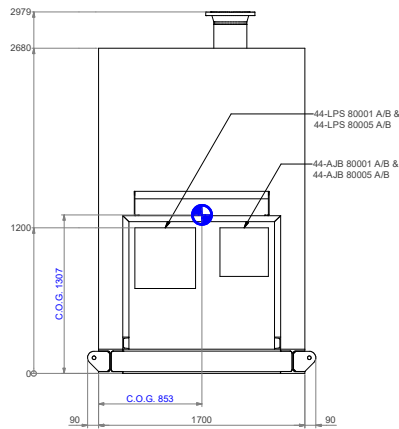
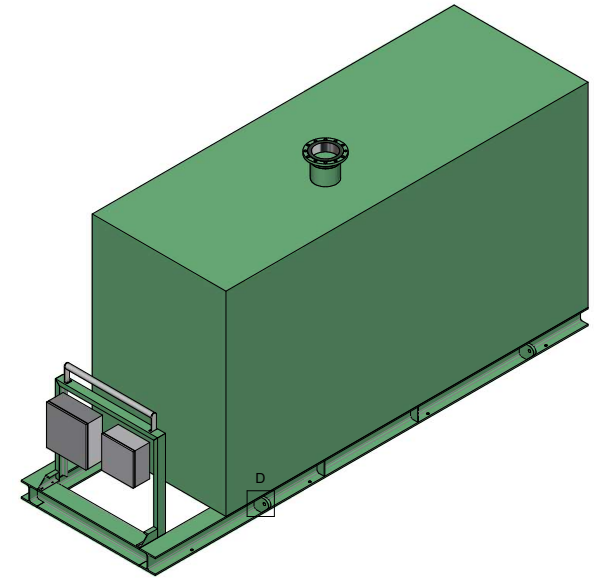
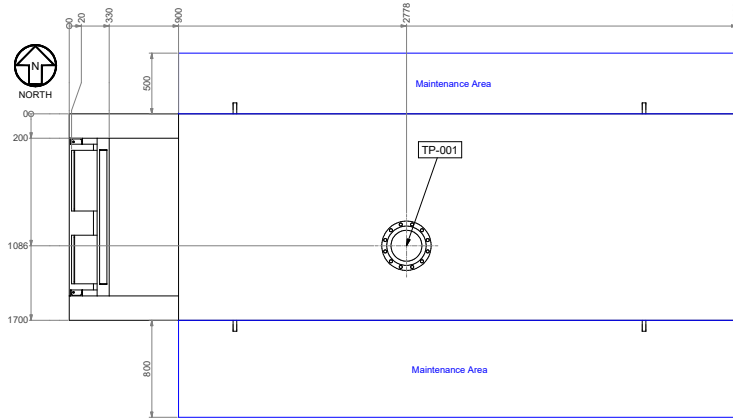
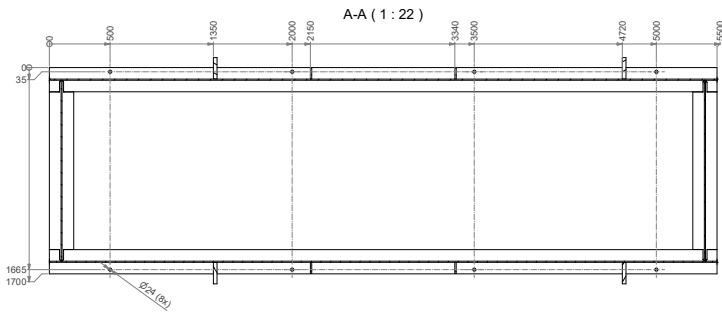

Type:8-T2-16-F1554 Gr.36-110-193

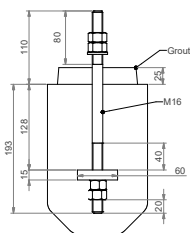

D (1:6) Lifting Points

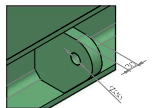

44M-80001 A/B & 44M-80005 A/B		Table		Weight Data SKID (Estimated)			NOZZLE DATA					
Description	Main Motor	ITEM No.	DESCRIPTION	TAG No.	ITEM	Empty lbs [kg]	Operational lbs [kg]	Nozzle	Description	Connection	Size	Rating
Technical Data	Rated Power: 250 kW Speed: 2980 rpm Power Supply: 6kV / 50 Hz / 3ph	1	Local Push Station	44-LPS 80001 A/B & 44-LPS 80005 A/B		18850	-	TP-001	Outlet	RF	10"	150#
		2	Junction box	44-AJB 80001 A/B & 44-AJB 80005 A/B	Skid	8550	{-}					

NOTES			
Subject		Projection	
80001 A/B 80005 A/B/C		First Angle	
Client: Arpa Based Polymer Company		Transmission: 15-05-2025	
Drawn By: ASIPC Project		Checked By: FVT	
Client Doc. No.		Drawn Date: 15-05-2025	
P&ID Rev. No.		Drawn By: MD	
Airpack Nederland BV Groningerlaan 40 4201 RW Zierikzee The Netherlands		Plant Location: East_Ondisore	
Telephone: +31 (0) 111 443495 Email: sales@airpack.nl URL: http://www.airpack.nl		Scale: 1:1 Access Ref: 23383-COM Drawing No: 23383-04B GAD	
Sheet 1 of 1		Sheet 1 of 1	