





CONTRACTOR:  	300 KT POLYETHYLENE PLANT ARYA SASOL POLYMER COMPANY (ASPC)	OWNER:  شرکت پلیمیر آریا ساسول ARYA SASOL POLYMER COMPANY آریا ساسول پلیمر																				
VENDOR LOGO: 	COMPRESSOR PANEL DRAWING LAYOUT	MC:  شرکت مهندسی و مشاوره ISED CO																				
Owner Document Number :	<table border="1"> <thead> <tr> <th>OWNER Project No.</th> <th>Vendor DOC.</th> <th>MR No.</th> <th>Vendor Code</th> <th>Discipline</th> <th>Unit</th> <th>Type</th> <th>Seq. No</th> <th>Rev.:</th> <th>Page</th> </tr> </thead> <tbody> <tr> <td>3944</td> <td>VD</td> <td>0171</td> <td>DYP</td> <td>RE</td> <td>400</td> <td>DWG</td> <td>0161</td> <td>02</td> <td>1 of 9</td> </tr> </tbody> </table>	OWNER Project No.	Vendor DOC.	MR No.	Vendor Code	Discipline	Unit	Type	Seq. No	Rev.:	Page	3944	VD	0171	DYP	RE	400	DWG	0161	02	1 of 9	
OWNER Project No.	Vendor DOC.	MR No.	Vendor Code	Discipline	Unit	Type	Seq. No	Rev.:	Page													
3944	VD	0171	DYP	RE	400	DWG	0161	02	1 of 9													

COMPRESSOR PANEL DRAWING LAYOUT





Project team advise: As there is no comment on dimension, Vendor is allowed to start fabrication but please change documents based on comments in Next Revision.

P.O. No.:	SHAU23-006-DYPNF-ASS	RESULT CODE : <input type="checkbox"/> AP <input checked="" type="checkbox"/> AN <input type="checkbox"/> CO <input type="checkbox"/> RE
MR. No.:	3944-SZP-RE-400-MRQ-0171	NEXT STATUS : <input type="checkbox"/> IFI <input type="checkbox"/> IFA <input type="checkbox"/> AFC <input checked="" type="checkbox"/> ASB or FIN
Item No. (Equipment No.):	POWDER CONVEYING SYSTEM(W-40001)	RESUBMISSION DATE:
Vendor Job No.:	PC2312	Approval or review hereunder shall not be considered to relieve Vendor/ Subcontractor of his responsibilities and liability under the Contract.

M.Shakiba

06-Oct-2025

Rev.	Date	Purpose of Issue	Prepared	Checked	Approved	AC Code
02	29.Sep,2025	Issue for Approval	B.C Yoo	Y.H Hong	M.H Yim	
01	18.Jul,2025	Issue for Approval	B.C Yoo	Y.H Hong	M.H Yim	
00	9.May,2025	Issue for Approval	B.C Yoo	Y.H Hong	M.H Yim	

CONTRACTOR:  	300 KT POLYETHYLENE PLANT ARYA SASOL POLYMER COMPANY (ASPC)	OWNER:  شرکت پلیمر آریا ساسول ARYA SASOL POLYMER COMPANY تهران، ایران								
VENDOR LOGO: 	COMPRESSOR PANEL DRAWING LAYOUT	MC:  شرکت مهندسی ایزدکو ISED CO تهران، ایران								
Owner Document Number :	OWNER Project No. 3944	Vendor DOC. VD	MR No. 0171	Vendor Code DYP	Discipline RE	Unit 400	Type DWG	Seq. No 0161	Rev.: 02	Page 2 of 9

Tabulation of Revised Pages

Page	Revision						Page	Revision						Page	Revision					
	00	01	02																	
1	X	X																		
2	X	X																		
3	X	X	X																	
4	X	X	X																	
5	X	X																		
6	X	X	X																	
7	X	X	X																	
8	X	X																		
9	X	X																		
10																				
11																				
12																				
13																				
14																				
15																				
16																				
17																				
18																				
19																				
20																				
21																				
22																				
23																				
24																				
25																				
26																				
27																				
28																				
29																				
30																				
31																				
32																				
33																				
34																				
35																				
36																				

No.	Description	Tag Number	Make	Model	Qty.
1	Running Indication Lamp (Green)	3H4	TBD	TBD	1
2	Fault Indication Lamp (Amber)	3H6	TBD	TBD	1
3	Start Pushbutton (Green)	2S4	TBD	TBD	1
4	Stop Pushbutton (Red)	2S6	TBD	TBD	1
5	Lamp Test Pushbutton (Black)	2S8	TBD	TBD	1
Terminal Strip Definition					
X1	Connection Pushbuttons & Lamps	X1	Phoenix Contact	3211760	21

INS General Comment:
 Vendor to clarify why manufacturer and model numbers
 have been deleted in this revision?
 Document can not be approved without this items.

GENERAL NOTES

NOTES
 1. BILL OF MATERIALS (BOM) AS PER THE LATEST WIRING DIAGRAM.

REF DRAWINGS	DWG.No.
Wiring Diagram	3944-VD-0171-DYP-RE-400-DIA-0002
I/O List	3944-VD-0171-DYP-RE-400-LST-0080
E&I System Config Diag.	3944-VD-0171-DYP-RE-400-DIA-0078

LEGEND

RESULT CODE: AP AN CO RE RESUBMISSION DATE:

NEXT STATUS: IFI IFA AFC ASB/IFIN

Approval or review hereunder shall not be construed to relieve Vendor/ Subcontractor of his responsibilities and liability under the Contract.

P.O. NO.:
 M.R. NO.:
 ITEM NO. (EQUIPMENT NO.):
 VENDRO JOB NO.:

REV.	DATE	PURPOSE OF ISSUE (P.O.I.)	PREP.	CHKD.	APPR.	AC.
03	26/Aug/25	ISSUED FOR APPROVAL	RT	RB	SC	--
02	16/Jul/25	ISSUED FOR APPROVAL	RT	RB	SC	--
01	25/Apr/25	ISSUED FOR APPROVAL	RT	RB	SC	--
00	24/Mar/25	ISSUED FOR APPROVAL	RT	RB	SC	--



PROJECT:
 300 KT POLYETHYLENE PLANT
 ARYA SASOL POLYMER COMPANY (ASPC)



DRAWING TITLE:
 PANEL LAYOUT DRAWING
 BILL OF MATERIALS FOR
 LOCAL CONTROL PANEL 44LCP-4001010

OWNER PROJECT NO.	VENDOR DWG.	MR NO.	VENDOR CODE	DISCIPLINE	UNIT	TYPE	SEQ.
3944	VD	0171	DYP	RE	400	DWG	0003

SCALE: NONE SIZE: A0 SHEET NO. 1 OF 34 REV. 03

44LCP-4001010

Front Side (Outside) View

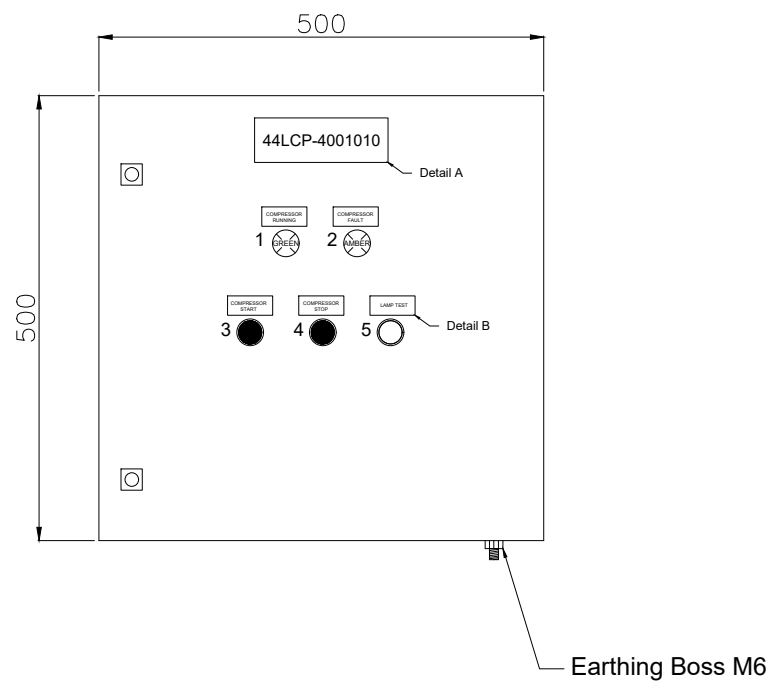

Front Side (Inside) View

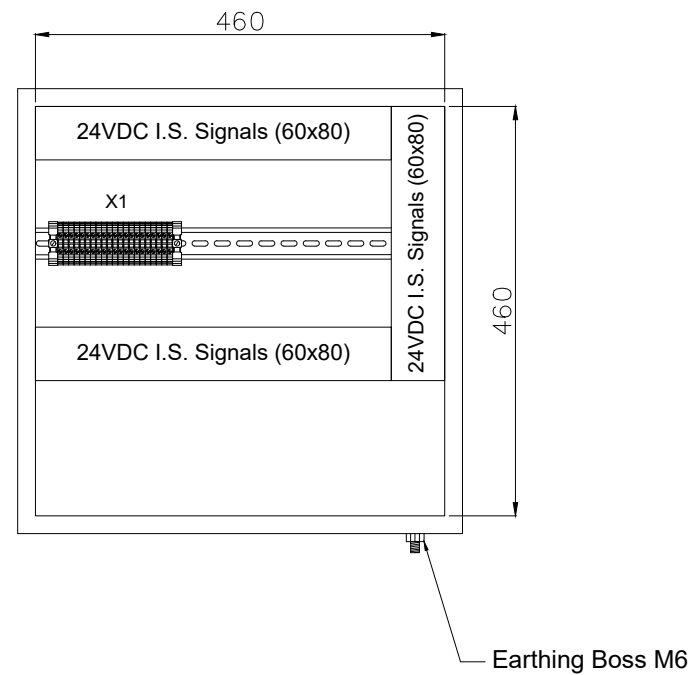

INS General Comment:
Based on the vendor's I/O list, the signals of the LCPs for all compressors are indicated as NIS. Considering that compressors C-40001A/B are installed in a hazardous area and their associated LCPs are equipped with switching devices (Start/Stop/Reset push buttons), the vendor is requested to confirm whether the indicated Ex e certification for the LCPs related to C-40001A/B is adequate and compliant with the area classification requirements.

- GENERAL NOTES**
- PANEL DIMENSIONS: 500x500x210mm
 - PANEL MATERIAL: SS316L STAINLESS STEEL
 - PANEL COLOR: RAL5017 (BLUE)
 - PANEL WALL THICKNESS: 1.6mm
 - PANEL WEIGHT: ~20kg
 - PANEL WILL BE RIGHT HINGED
 - AREA CLASSIFICATION: Ex II, 3G, IIC T3 Eex'e
 - AMBIENT TEMPERATURE: 5°C to +48°C
 - INGRESS PROTECTION: IP65
 - CABLE RACEWAYS SHALL HAVE NO LESS THAN 20% SPARE CAPACITY.
 - DIN RAIL TYPE: NS35
 - BLUE SLOTTED CABLE TRUNKING WILL BE PROVIDED FOR INTRINSICALLY SAFE SIGNALS.
 - SPARES WILL BE PLUGGED WITH SUS EX PLUG
 - GLANDS WILL BE Ex d IP65 NICKEL PLATED BRASS TYPE GLANDS
 - ALL DIMENSIONS IN mm.
 - EXTERNAL EARTH BOLT AND RELATED PARTS ARE ALL COPPER.
 - INDICATION LAMP VOLTAGE: 24VDC

REF DRAWINGS	DWG.No.
Wiring Diagram	3944-VD-0171-DYP-RE-400-DIA-0002
I/O List	3944-VD-0171-DYP-RE-400-LST-0080
E&I System Config Diag.	3944-VD-0171-DYP-RE-400-DIA-0078

Bottom View

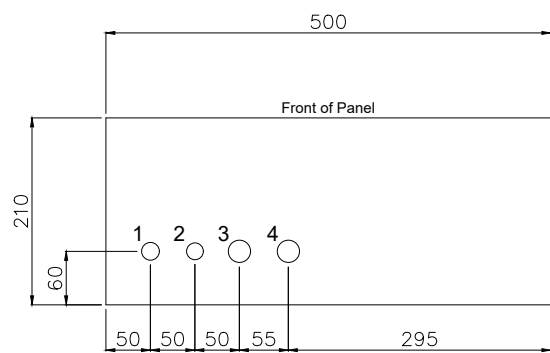

Gland Entry Details

- M20 - 1x (Breather)
- M20 - 1x (Spare)
- M25 - 1x (Cable for Pushbuttons & Lamps)
- M25 - 1x (Spare)

Back (Outside) View Mounting Details

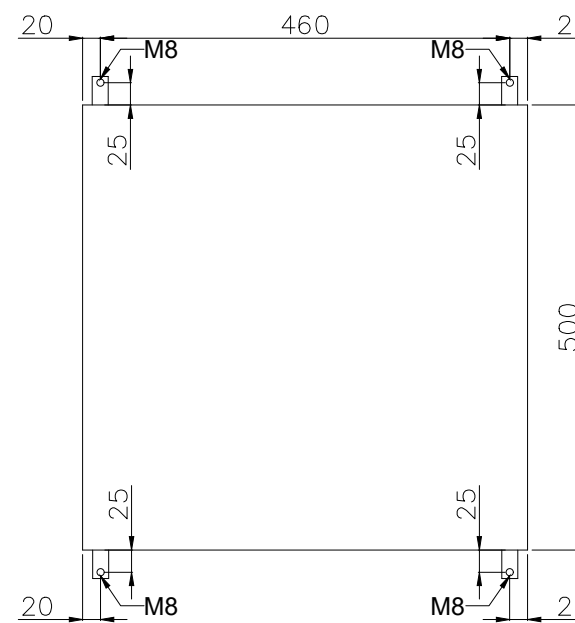

LEGEND

RESULT CODE: AP AN CO RE RESUBMISSION DATE:

NEXT STATUS: IFI IFA IAF ASB/IFIN

Approval or review hereunder shall not be construed to relieve Vendor/ Subcontractor of his responsibilities and liability under the Contract.

P.O. NO.:

M.R. NO.:

ITEM NO. (EQUIPMENT NO.):

VENDRO JOB NO.:

REV.	DATE	PURPOSE OF ISSUE (P.O.I.)	PREP.	CHKD.	APPR.	AC.
03	26/Aug/25	ISSUED FOR APPROVAL		RT	RB	SC
02	16/Jul/25	ISSUED FOR APPROVAL		RT	RB	SC
01	25/Apr/25	ISSUED FOR APPROVAL		RT	RB	SC
00	24/Mar/25	ISSUED FOR APPROVAL		RT	RB	SC

OWNER:



PROJECT:
300 KT POLYETHYLENE PLANT
ARYA SASOL POLYMER COMPANY (ASPC)

MC:
ISEDCO (Logo) **گروه صنعتی ایزدکو** (Logo)

CONTRACTOR: **SAZEH CONSULTANTS** (Logo) **سازش** (Logo)
VENDOR: **DYPNF** (Logo)

DRAWING TITLE:
PANEL LAYOUT DRAWING
LOCAL CONTROL PANEL 44LCP-4001010

OWNER PROJECT NO.	VENDOR DWG.	MR NO.	VENDOR CODE	DISCIPLINE	UNIT	TYPE	SEQ.
3944	VD	0171	DYP	RE	400	DWG	0003
SCALE: NONE	SIZE: A0	SHEET NO. 2	OF 34	REV. 03			

PFJBIA-40060i

Front Side (Outside) View

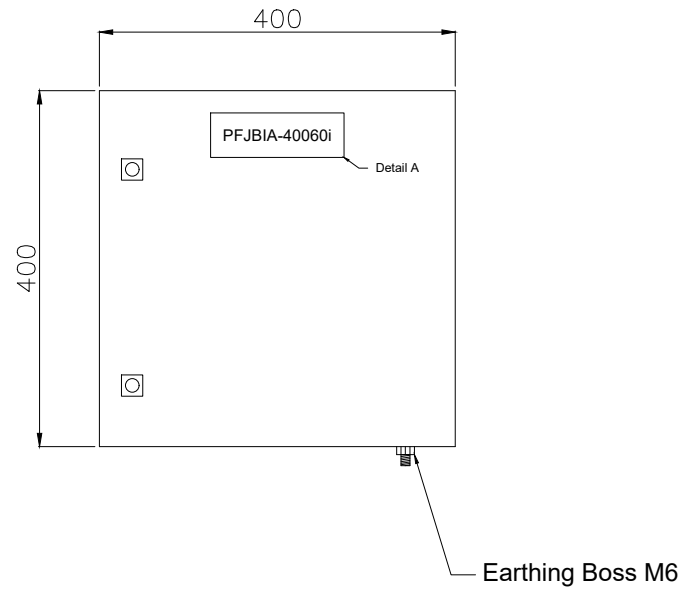

Front Side (Inside) View

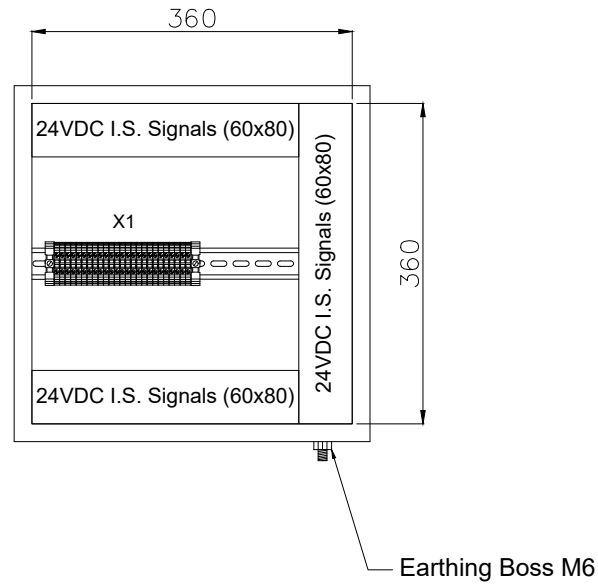

Side (Outside) View

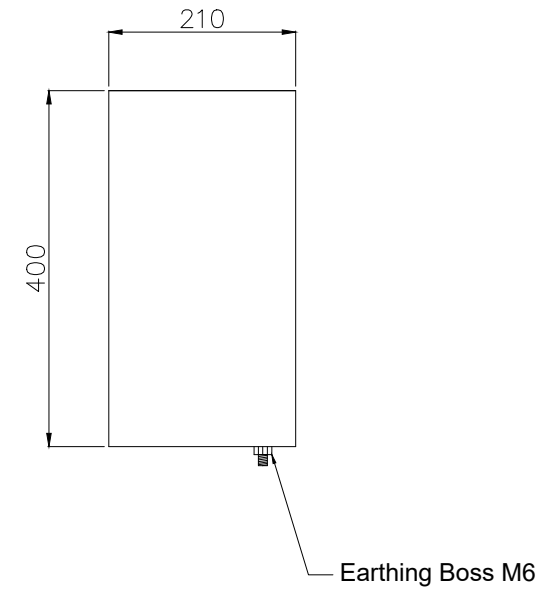

Bottom View

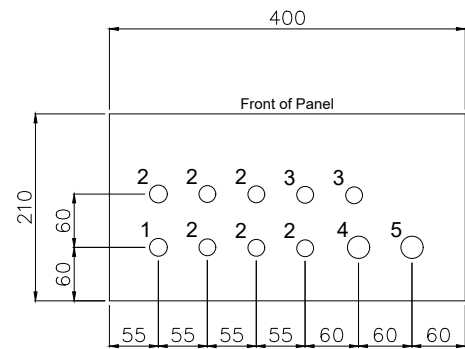

Gland Entry Details

1. M20 - 1x (Breather)
2. M20 - 6x (Cables from Transmitters)
3. M20 - 2x (Spare)
4. M25 - 1x (Multipair Cable from Customer)
5. M25 - 1x (Spare)

Back (Outside) View Mounting Details

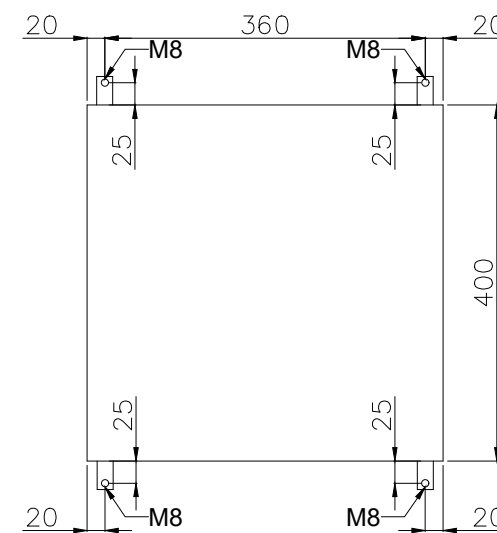

GENERAL NOTES

- NOTES
1. PANEL DIMENSIONS: 400x400x210mm
 2. PANEL MATERIAL: SS316L STAINLESS STEEL
 3. PANEL COLOR: RAL5017 (BLUE)
 4. PANEL WALL THICKNESS: 1.6mm
 5. PANEL WEIGHT: ~15Kg
 6. PANEL WILL BE RIGHT HINGED
 7. AREA CLASSIFICATION: Ex II 3G IIC T3 Eex'e'
 8. AMBIENT TEMPERATURE: 5°C/+48°C
 9. INGRESS PROTECTION: IP65
 10. CABLE RACEWAYS SHALL HAVE NO LESS THAN 20% SPARE CAPACITY.
 11. DIN RAIL TYPE: NS35
 12. BLUE SLOTTED CABLE TRUNKING WILL BE PROVIDED FOR INTRINSICALLY SAFE SIGNALS.
 13. SPARES WILL BE PLUGGED WITH SUS Ex PLUG
 14. GLANDS WILL BE Ex d IP65 NICKEL PLATED BRASS TYPE GLANDS
 15. ALL DIMENSIONS IN mm.
 16. EXTERNAL EARTH BOLT AND RELATED PARTS ARE ALL COPPER.

REF DRAWINGS	DWG.No.
Wiring Diagram	3944-VD-0171-DYP-RE-400-DIA-0002
I/O List	3944-VD-0171-DYP-RE-400-LST-0080
E&I System Config Diag.	3944-VD-0171-DYP-RE-400-DIA-0078

LEGEND

RESULT CODE: AP AN CO RE

NEXT STATUS: IFI IFA JAF ASB/IFIN

Approval or review hereunder shall not be construed to relieve Vendor/ Subcontractor of his responsibilities and liability under the Contract.

P.O. NO.:

M.R. NO.:

ITEM NO. (EQUIPMENT NO.):

VENDRO JOB NO.:

REV.	DATE	PURPOSE OF ISSUE (P.O.I.)	PREP.	CHKD.	APPR.	AC.
03	26/Aug/25	ISSUED FOR APPROVAL	RT	RB	SC	-
02	16/Jul/25	ISSUED FOR APPROVAL	RT	RB	SC	-
01	25/Apr/25	ISSUED FOR APPROVAL	RT	RB	SC	-
00	24/Mar/25	ISSUED FOR APPROVAL	RT	RB	SC	-

OWNER:



PROJECT:

300 KT POLYETHYLENE PLANT
ARYA SASOL POLYMER COMPANY (ASPC)

MC:



CONTRACTOR:



VENDOR:



DRAWING TITLE:
PANEL LAYOUT DRAWING
LOCAL CONTROL PANEL PFJBIA-40060i

OWNER PROJECT NO.	VENDOR DWG.	MR NO.	VENDOR CODE	DISCIPLINE	UNIT	TYPE	SEQ.
3944	VD	0171	DYP	RE	400	DWG	0003
SCALE:	NONE	SIZE:	A0	SHEET NO.	3	OF 34	REV. 03

No.	Description	Tag Number	Make	Model	Qty.
1	Running Indication Lamp (Green)	3H4	TBD	TBD	1
2	Fault Indication Lamp (Amber)	3H6	TBD	TBD	1
3	Start Pushbutton (Green)	2S4	TBD	TBD	1
4	Stop Pushbutton (Red)	2S6	TBD	TBD	1
5	Lamp Test Pushbutton (Black)	2S8	TBD	TBD	1
Terminal Strip Definition					
X1	Connection Pushbuttons & Lamps	X1	Phoenix Contact	3211760	21

GENERAL NOTES

NOTES
1. BILL OF MATERIALS (BOM) AS PER THE LATEST WIRING DIAGRAM.

REF DRAWINGS	DWG.No.
Wiring Diagram	3944-VD-0171-DYP-RE-400-DIA-0002
I/O List	3944-VD-0171-DYP-RE-400-LST-0080
E&I System Config Diag.	3944-VD-0171-DYP-RE-400-DIA-0078

LEGEND

RESULT CODE: AP AN CO RE

NEXT STATUS: IFI IFA AFC ASB/IFIN

Approval or review hereunder shall not be construed to relieve Vendor/ Subcontractor of his responsibilities and liability under the Contract.

P.O. NO.:
M.R. NO.:
ITEM NO. (EQUIPMENT NO.):
VENDRO JOB NO.:

REV.	DATE	PURPOSE OF ISSUE (P.O.I.)	PREP.	CHKD.	APPR.	AC.
03	26/Aug/25	ISSUED FOR APPROVAL	RT	RB	SC	--
02	16/Jul/25	ISSUED FOR APPROVAL	RT	RB	SC	--
01	25/Apr/25	ISSUED FOR APPROVAL	RT	RB	SC	--
00	24/Mar/25	ISSUED FOR APPROVAL	RT	RB	SC	--

OWNER:

PROJECT:
300 KT POLYETHYLENE PLANT
ARYA SASOL POLYMER COMPANY (ASPC)

MC:
 

CONTRACTOR:
 

VENDOR:

DRAWING TITLE:
PANEL LAYOUT DRAWING
BILL OF MATERIALS FOR
LOCAL CONTROL PANEL 44LCP-4002010

OWNER PROJECT NO.	VENDOR DWG.	MR NO.	VENDOR CODE	DISCIPLINE	UNIT	TYPE	SEQ.
3944	VD	0171	DYP	RE	400	DWG	0003
SCALE:	NONE	SIZE:	A0	SHEET NO.	4	OF 34	REV. 03

44LCP-4002010

Front Side (Outside) View

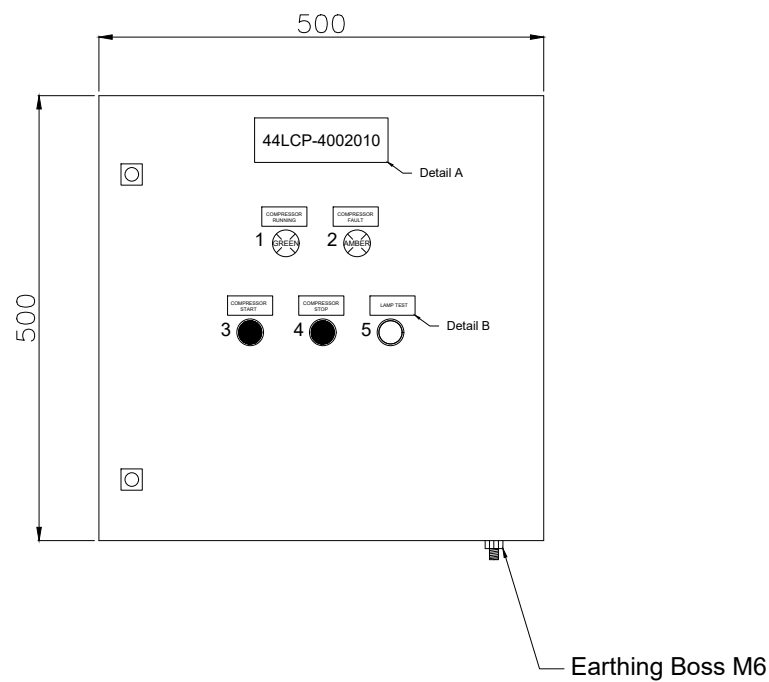

Front Side (Inside) View

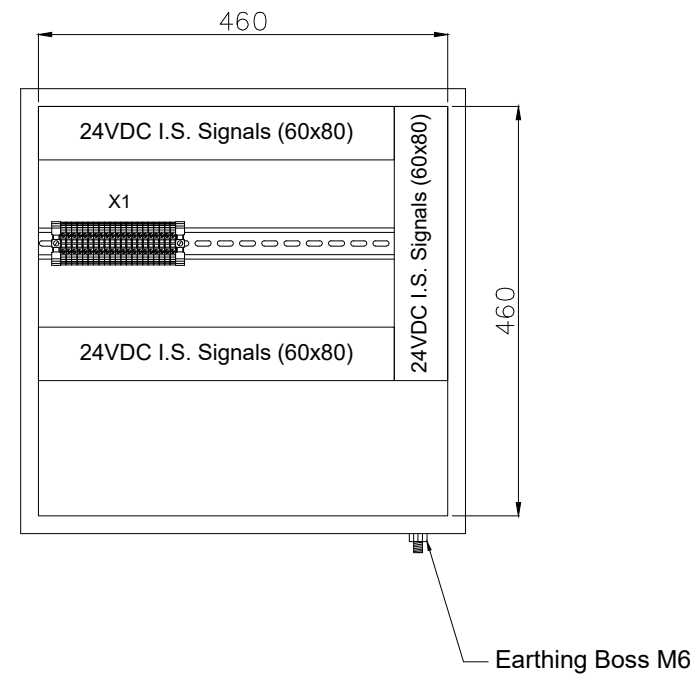

Side (Outside) View

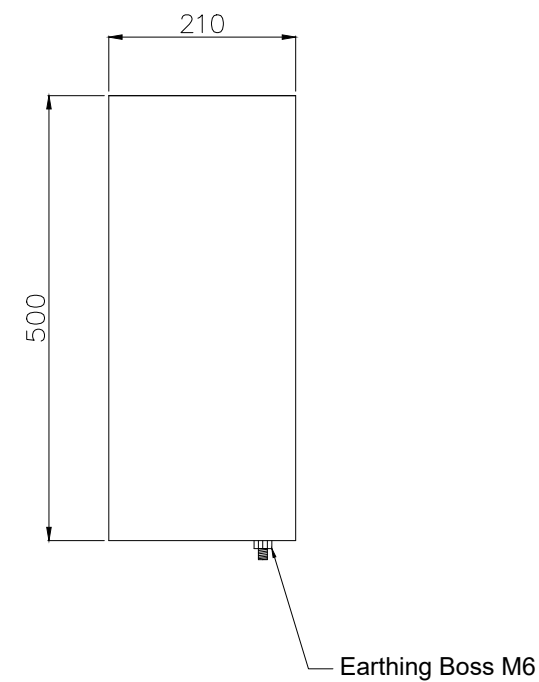

Bottom View

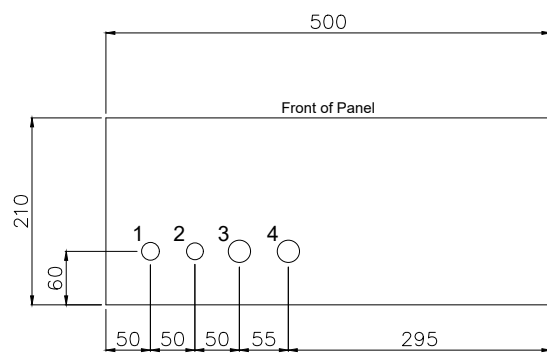

Gland Entry Details

1. M20 - 1x (Breather)
2. M20 - 1x (Spare)
3. M25 - 1x (Cable for Pushbuttons & Lamps)
4. M25 - 1x (Spare)

Back (Outside) View Mounting Details

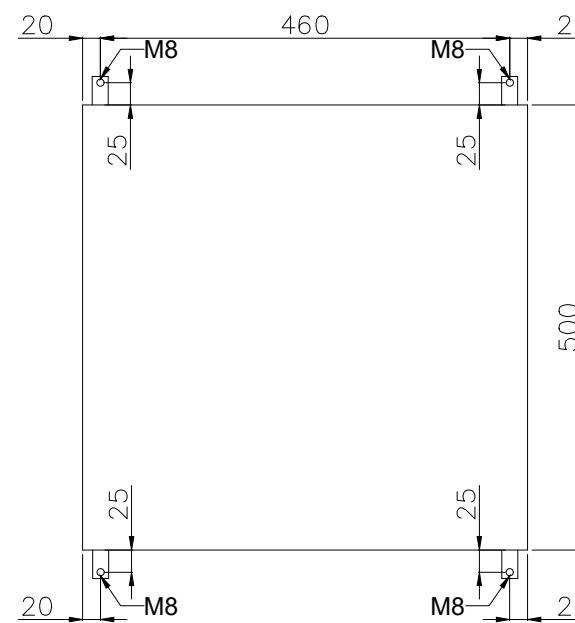

GENERAL NOTES

- NOTES
1. PANEL DIMENSIONS: 500x500x210mm
 2. PANEL MATERIAL: SS316L STAINLESS STEEL
 3. PANEL COLOR: RAL5017 (BLUE)
 4. PANEL WALL THICKNESS: 1.6mm
 5. PANEL WEIGHT: ~20Kg
 6. PANEL WILL BE RIGHT HINGED
 7. AREA CLASSIFICATION: Ex II 3G IIC T3 Eex'e'
 8. AMBIENT TEMPERATURE: 5°C/+48°C
 9. INGRESS PROTECTION: IP65
 10. CABLE RACEWAYS SHALL HAVE NO LESS THAN 20% SPARE CAPACITY.
 11. DIN RAIL TYPE: NS35
 12. BLUE SLOTTED CABLE TRUNKING WILL BE PROVIDED FOR INTRINSICALLY SAFE SIGNALS.
 13. SPARES WILL BE PLUGGED WITH SUS Ex PLUG
 14. GLANDS WILL BE Ex'd IP65 NICKEL PLATED BRASS TYPE GLANDS
 15. ALL DIMENSIONS IN mm.
 16. EXTERNAL EARTH BOLT AND RELATED PARTS ARE ALL COPPER.
 17. INDICATION LAMP VOLTAGE: 24VDC

REF DRAWINGS	DWG.No.
Wiring Diagram	3944-VD-0171-DYP-RE-400-DIA-0002
I/O List	3944-VD-0171-DYP-RE-400-LST-0080
E&I System Config Diag.	3944-VD-0171-DYP-RE-400-DIA-0078

LEGEND

RESULT CODE: AP AN CO RE

NEXT STATUS: IFI IFA JAF ASB/IFIN

Approval or review hereunder shall not be construed to relieve Vendor/ Subcontractor of his responsibilities and liability under the Contract.

P.O. NO.:

M.R. NO.:

ITEM NO. (EQUIPMENT NO.):

VENDOR JOB NO.:

REV.	DATE	PURPOSE OF ISSUE (P.O.I.)	PREP.	CHKD.	APPR.	AC.
03	26/Aug/25	ISSUED FOR APPROVAL	RT	RB	SC	-
02	16/Jul/25	ISSUED FOR APPROVAL	RT	RB	SC	-
01	25/Apr/25	ISSUED FOR APPROVAL	RT	RB	SC	-
00	24/Mar/25	ISSUED FOR APPROVAL	RT	RB	SC	-

OWNER:



PROJECT:

300 KT POLYETHYLENE PLANT
ARYA SASOL POLYMER COMPANY (ASPC)

MC:



CONTRACTOR:



VENDOR:



DRAWING TITLE:
PANEL LAYOUT DRAWING
LOCAL CONTROL PANEL 44LCP-4002010

OWNER PROJECT NO.	VENDOR DWG.	MR NO.	VENDOR CODE	DISCIPLINE	UNIT	TYPE	SEQ.
3944	VD	0171	DYP	RE	400	DWG	0003
SCALE:	NONE	SIZE:	A0	SHEET NO.	5 OF 34	REV.	03

PFJBIA-40061i

Front Side (Outside) View

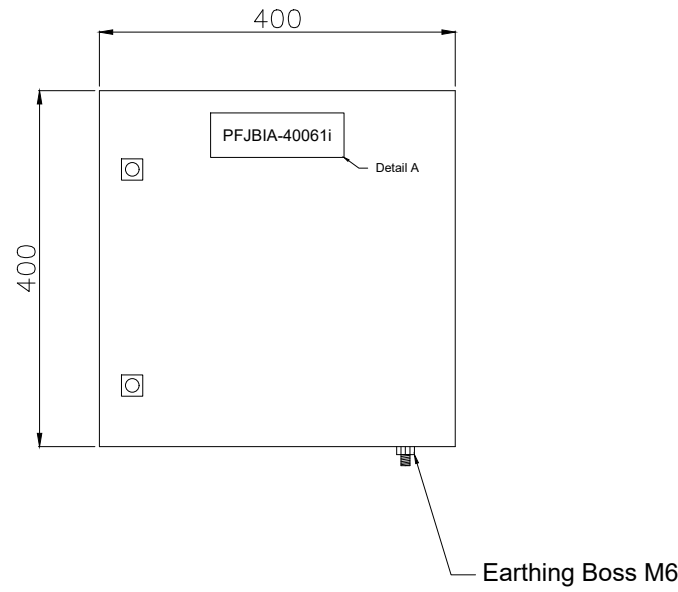

Front Side (Inside) View

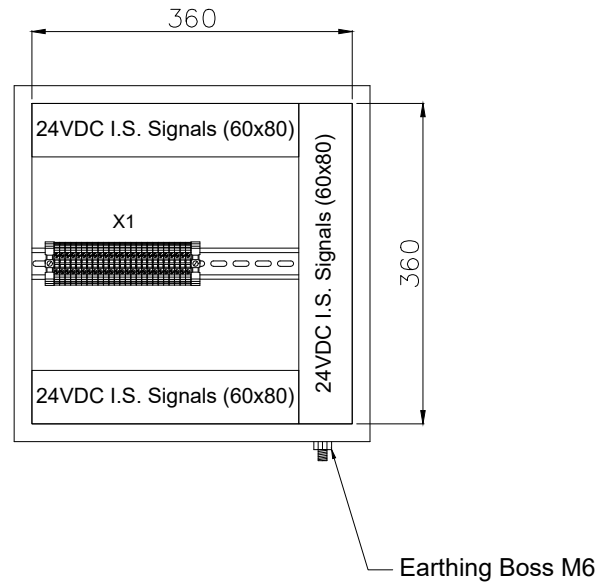

Side (Outside) View

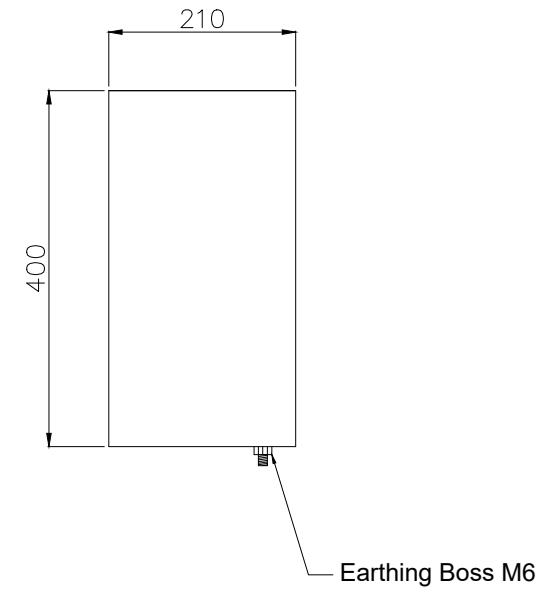

Bottom View

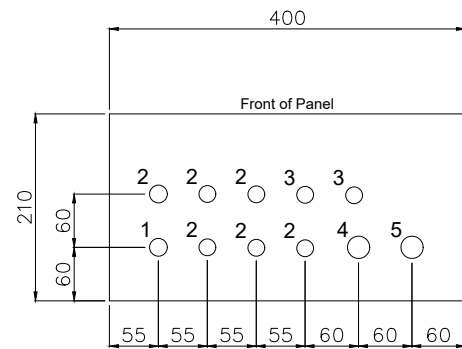

Gland Entry Details

1. M20 - 1x (Breather)
2. M20 - 6x (Cables from Transmitters)
3. M20 - 2x (Spare)
4. M25 - 1x (Multipair Cable from Customer)
5. M25 - 1x (Spare)

Back (Outside) View Mounting Details

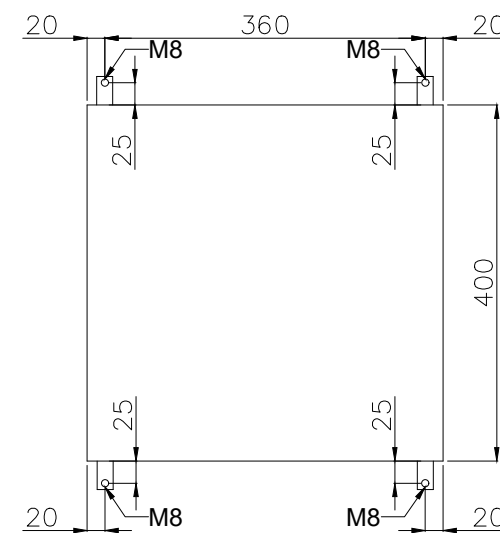

GENERAL NOTES

- NOTES
1. PANEL DIMENSIONS: 400x400x210mm
 2. PANEL MATERIAL: SS316L STAINLESS STEEL
 3. PANEL COLOR: RAL5017 (BLUE)
 4. PANEL WALL THICKNESS: 1.6mm
 5. PANEL WEIGHT: ~15Kg
 6. PANEL WILL BE RIGHT HINGED
 7. AREA CLASSIFICATION: Ex II 3G IIC T3 Eex'e'
 8. AMBIENT TEMPERATURE: 5°C/+48°C
 9. INGRESS PROTECTION: IP65
 10. CABLE RACEWAYS SHALL HAVE NO LESS THAN 20% SPARE CAPACITY.
 11. DIN RAIL TYPE: NS35
 12. BLUE SLOTTED CABLE TRUNKING WILL BE PROVIDED FOR INTRINSICALLY SAFE SIGNALS.
 13. SPARES WILL BE PLUGGED WITH SUS Ex PLUG
 14. GLANDS WILL BE Ex d IP65 NICKEL PLATED BRASS TYPE GLANDS
 15. ALL DIMENSIONS IN mm.
 16. EXTERNAL EARTH BOLT AND RELATED PARTS ARE ALL COPPER.

REF DRAWINGS	DWG.No.
Wiring Diagram	3944-VD-0171-DYP-RE-400-DIA-0002
I/O List	3944-VD-0171-DYP-RE-400-LST-0080
E&I System Config Diag.	3944-VD-0171-DYP-RE-400-DIA-0078

LEGEND

RESULT CODE: AP AN CO RE RESUBMISSION DATE:

NEXT STATUS: IFI IFA JAF ASB/IFIN

Approval or review hereunder shall not be construed to relieve Vendor/ Subcontractor of his responsibilities and liability under the Contract.

P.O. NO.:

M.R. NO.:

ITEM NO. (EQUIPMENT NO.):

VENDRO JOB NO.:

REV.	DATE	PURPOSE OF ISSUE (P.O.I.)	PREP.	CHKD.	APPR.	AC.
03	26/Aug/25	ISSUED FOR APPROVAL	RT	RB	SC	-
02	16/Jul/25	ISSUED FOR APPROVAL	RT	RB	SC	-
01	25/Apr/25	ISSUED FOR APPROVAL	RT	RB	SC	-
00	24/Mar/25	ISSUED FOR APPROVAL	RT	RB	SC	-

OWNER:



PROJECT:

300 KT POLYETHYLENE PLANT
ARYA SASOL POLYMER COMPANY (ASPC)

MC:



CONTRACTOR:



VENDOR:



DRAWING TITLE:
PANEL LAYOUT DRAWING
LOCAL CONTROL PANEL PFJBIA-40061i

OWNER PROJECT NO.	VENDOR DWG.	MR NO.	VENDOR CODE	DISCIPLINE	UNIT	TYPE	SEQ.
3944	VD	0171	DYP	RE	400	DWG	0003
SCALE:	NONE	SIZE:	A0	SHEET NO.	6 OF 34	REV.	03

NAME PLATE DETAILS

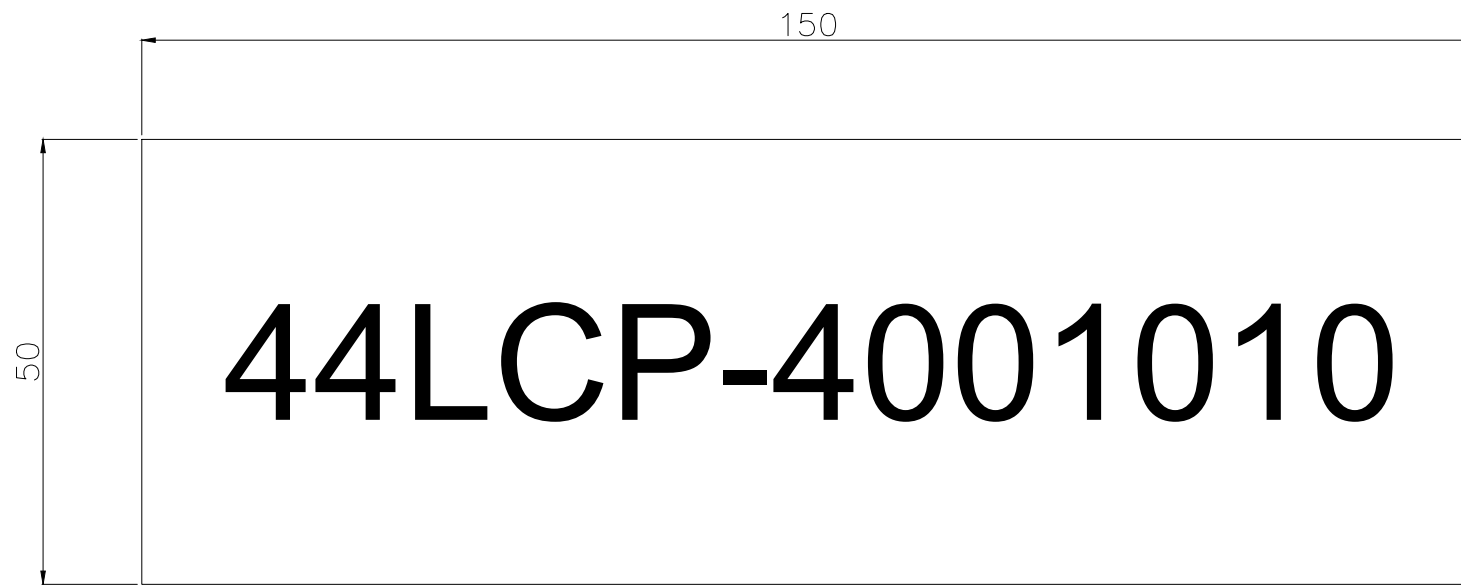

DETAIL A
SCALE 10:1
BLACK LETTERS WITH WHITE
BACKGROUND

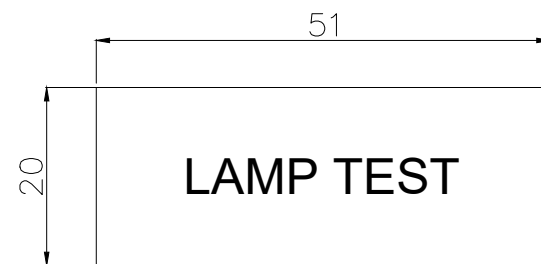

DETAIL B
SCALE 10:1
BLACK LETTERS WITH WHITE
BACKGROUND

GENERAL NOTES

- NOTES
1. NAME PLATES WILL BE MADE OF STAINLESS STEEL
2. NAME PLATES WILL BE MOUNTED ON THE INSIDE OF THE DOOR AND ON THE OUTSIDE OF THE DOOR

REF DRAWINGS	DWG.No.
Wiring Diagram	3944-VD-0171-DYP-RE-400-DIA-0002
I/O List	3944-VD-0171-DYP-RE-400-LST-0080
E&I System Config Diag.	3944-VD-0171-DYP-RE-400-DIA-0078

LEGEND

RESULT CODE: AP AN CO RE RESUBMISSION DATE:

NEXT STATUS: IFI IFA AFC ASB/IFIN

Approval or review hereunder shall not be construed to relieve Vendor/ Subcontractor of his responsibilities and liability under the Contract.

P.O. NO.:

M.R. NO.:

ITEM NO. (EQUIPMENT NO.):

VENDRO JOB NO.:

REV.	DATE	PURPOSE OF ISSUE (P.O.I.)	PREP.	CHKD.	APPR.	AC.
03	26/Aug/25	ISSUED FOR APPROVAL	RT	RB	SC	--
02	16/Jul/25	ISSUED FOR APPROVAL	RT	RB	SC	--
01	25/Apr/25	ISSUED FOR APPROVAL	RT	RB	SC	--
00	24/Mar/25	ISSUED FOR APPROVAL	RT	RB	SC	--

OWNER:



PROJECT:

300 KT POLYETHYLENE PLANT
ARYA SASOL POLYMER COMPANY (ASPC)

MC:



CONTRACTOR:



VENDOR:



DRAWING TITLE:
PANEL LAYOUT DRAWING
LOCAL CONTROL PANEL 44AJB-80005C

OWNER DOC. NO.						
OWNER PROJECT NO.	VENDOR DWG.	MR NO.	VENDOR CODE	DISCIPLINE	UNIT	TYPE SEQ.
3944	VD	0171	DYP	RE	400	DWG 0003
SCALE: NONE	SIZE: A0	SHEET NO. 34	OF 34	REV. 03		