





OWNER:  شرکت سست و سویی توهمه ایران (سهامی خاص)	BUSHEHR PETROCHEMICAL COMPANY MEG PLANT						EPC CONTRACTOR:  Chagalesh-Enerchimi-Steam Joint Venture BUPC-MEG PLANT PROJECT		
	PULSATION DAMPER MECHANICAL STRENGHT CALCULATION FOR EMERGENCY INSTRUMENT AIR COMPRESSOR								
MC :  شرکت سست و سویی توهمه ایران (سهامی خاص)							Project	Area	Phase
Owner Document Number: 17811-24D	BU	20	VD	303	ME	CAL	0078	Rev.:	Page
								02	1 of 62

PULSATION DAMPER MECHANICAL STRENGHT CALCULATION FOR EMERGENCY INSTRUMENT AIR COMPRESSOR

Rev.	Date	Purpose of Issue	Prepared	Checked	Approved	AC Code
02	23/06/2022	Issue For Approve	KP	CL	JR	
01	09/05/2022	Issue For Approve	KP	CL	JR	
00	26/04/2022	Issue For Approve	KP	CL	JR	
					Class: 1	Phase: P

Report – Instrument air inlet_LI4731 C220006CLC007

PV-Elite Calculation Summary

Client: Airpack Nederland BV.
Client location: Zierikzee
Ref number client: 17811-OO-0702(KP)

PPV Engineering

Author: H.Hoezen
- Telephone: +31 (0)594 581010
- E-mail: h.hoezen@ppv-engineering.nl

June 22, 2022
Order number: P22-115-01
Document number: 22-11501-C05
Revision: 1

Table of Contents

Cover Sheet	2
Vessel Design Summary:	3
Nozzle Summary:	5
Nozzle Schedule:	6
Bill of Material:	7
Input Echo:	8
Internal Pressure Calculations:	13
Element and Detail Weights:	18
Nozzle Flange MAWP:	20
Nozzle Calcs.: N2	21
Nozzle Calcs.: N3	24
Nozzle Calcs.: Noz N1	27

Pulsation damper inlet
C220006CLC007
Static calculation

DESIGN CALCULATION

In Accordance with ASME Section VIII Division 1

ASME Code Version : 2021

Analysis Performed by : PPV-Engineering B.V.

Job File : ...\Instrument air inlet_LI4731.pvdb

Date of Analysis : Jun 21,2022 9:22am

PV Elite 24 SP1, March 2022

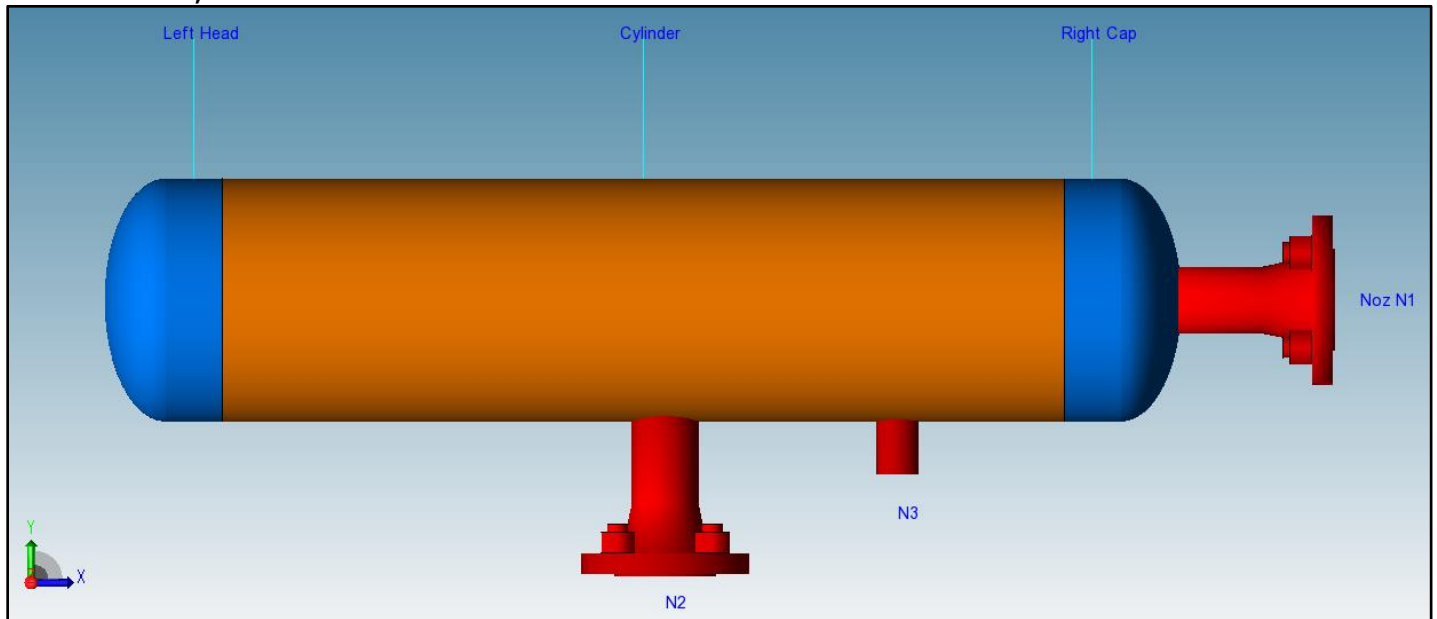

Pulsation damper inlet

C220006CLC007

Static calculation

PV Elite 24 SP1 Licensee: PPV-Engineering B.V.

FileName : Instrument air inlet_LI4731

Vessel Design Summary: Step: 15 9:22am Jun 21, 2022

Vessel Design Summary:

ASME Code, Section VIII Division 1, 2021

Diameter Spec : 219.100 mm OD
Vessel Design Length, Tangent to Tangent 862.63 mm
Specified Datum Line Distance 51.31 mm
Internal Design Temperature 85 °C
Internal Design Pressure 1.250 MPa
External Design Temperature 85 °C
Maximum Allowable Working Pressure 1.815 MPa
Shop Test Pressure 2.550 MPa
Required Minimum Design Metal Temperature -28.9 °C
Warmest Computed Minimum Design Metal Temperature -38.0 °C
Wind Design Code No Wind Loads
Earthquake Design Code No Seismic

Materials of Construction:

Component Type	Material	Class	Thickness	UNS #	Normalized	Impact Tested
Shell	SA-106 B	K03006	No	No
Head	SA-234 WPB	K03006	No	No
Nozzle	SA-106 B	K03006	No	No
Nozzle Flg	SA-105	K03504	No	No

Normalized is determined based on the UCS-66 material curve selection and Figure UCS-66.

Impact Tested is based on material selection and material data properties.

Element Pressures and MAWP (MPa & mm):

Element Description or Type	Design Pressure + Stat. head	Ext. Press.	Element M.A.W.P	Total Corrosion Allowance	Str. Flg. Gov.	In Creep Range
Left Head	1.250	0.00	4.830	3.0000	Yes	No
Cylinder	1.250	0.00	3.864	3.0000	N/A	No
Right Cap	1.250	0.00	4.830	3.0000	Yes	No

Element Types and Properties:

Element Type	"To" Elev mm	Element Length mm	Nominal Thickness mm	Finished Thickness mm	Reqd Thk Internal mm	Reqd Thk External mm	Long Eff	Circ Eff
Ellipse	0.0	51.3	8.2	8.2	4.5	...	0.85	0.85
Cylinder	760.0	760.0	8.2	7.2	4.5	...	0.85	0.85
Ellipse	811.3	51.3	8.2	8.2	4.5	...	0.85	0.85

Pulsation damper inlet

C220006CLC007

Static calculation

PV Elite 24 SP1 Licensee: PPV-Engineering B.V.

FileName : Instrument air inlet_LI4731 -----

Vessel Design Summary: Step: 15 9:22am Jun 21,2022

Weights:

Fabricated - Bare W/O Removable Internals	51.8	kgm
Shop Test - Fabricated + Water (Full)	82.4	kgm
Shipping - Fab. + Rem. Intls.+ Shipping App.	51.8	kgm
Erected - Fab. + Rem. Intls.+ Insul. (etc)	51.8	kgm
Empty - Fab. + Intls. + Details + Wghts.	51.8	kgm
Operating - Empty + Operating Liquid (No CA)	51.8	kgm
Field Test - Empty Weight + Water (Full)	82.4	kgm

PV Elite is a trademark of Hexagon AB, 2022, All rights reserved.

Pulsation damper inlet

C220006CLC007

Static calculation

PV Elite 24 SP1 Licensee: PPV-Engineering B.V.

FileName : Instrument air inlet_LI4731

Nozzle Summary: Step: 13 9:22am Jun 21, 2022

Nozzle Calculation Summary (MPa & mm):

Description	MAWP	Ext	MAPNC	UG-45	[tr]	Weld Path	Areas or Stresses
N2	3.864	OK	4.50	OK	No Calc[*]
N3	3.864	OK	4.50	OK	No Calc[*]
Noz N1	4.83	OK	4.50	OK	No Calc[*]

Nozzle MAWP Summary:

Minimum MAWP Nozzles : 3.864 Nozzle : N3

Minimum MAWP Shells/Flanges : 1.815 MPa

Computed Vessel M.A.W.P. : 1.815 MPa

[*] - This was a small opening and the areas were not computed.

Note: MAWPs (Internal Case) shown above are at the High Point.

Multiple output lines for the same nozzle indicates required Code calculations in both the longitudinal and circumferential planes of reinforcement where applicable.

Check the Spatial Relationship between the Nozzles:

From Node	Nozzle Description	X Coordinate mm	Layout Angle deg	Dia. Limit mm
20	N2	451.315	270.000	97.700
20	N3	661.315	270.000	54.672
30	Noz N1	0.000	0.000	97.700

The nozzle spacing is computed by the following:

= $\sqrt{l^2 + lc^2}$ where

l - Arc length along the inside vessel surface in the long. direction.

lc - Arc length along the inside vessel surface in the circ. direction

If any interferences/violations are found, they will be noted below.

No interference violations have been detected!

PV Elite is a trademark of Hexagon AB, 2022, All rights reserved.

Pulsation damper inlet

C220006CLC007

Static calculation

PV Elite 24 SP1 Licensee: PPV-Engineering B.V.

FileName : Instrument air inlet_LI4731

Nozzle Schedule: Step: 12 9:22am Jun 21, 2022

Nozzle Schedule:

Description	Nominal or Actual Size	Schd or FVC Type	Flg Type	Nozzle O/Dia mm	Wall Thk mm	Reinforcing Pad Diameter	Pad Thk mm	Cut Length mm	Flg Class
N3	38 mm	Actual	None	38.1	8.382	56	...
N2	50 mm	160	WNF	60.3	8.738	85	150
Noz N1	50 mm	160	WNF	60.3	8.738	82	150

General Notes for the above table:

The Cut Length is the Outside Projection + Inside Projection + Drop + In Plane Shell Thickness. This value does not include weld gaps, nor does it account for shrinkage.

In the case of Oblique Nozzles, the Outside Diameter must be increased. The Re-Pad WIDTH around the nozzle is calculated as follows:
Width of Pad = (Pad Outside Dia. (per above) - Nozzle Outside Dia.)/2

For hub nozzles, the thickness and diameter shown are those of the smaller and thinner section.

Nozzle Material and Weld Fillet Leg Size Details (mm):

Description	Material	Shl Grve Weld	Noz Shl/Pad Weld	Pad OD Weld	Pad Grve Weld	Inside Weld
N3	SA-106 B	8.340	6.000
N2	SA-106 B	8.340	6.000
Noz N1	SA-106 B	7.160	6.000

Note: The Outside projections below do not include the flange thickness.

Nozzle Miscellaneous Data:

Description	Elev/Distance From Datum mm	Layout Angle deg	Proj Outside mm	Proj Inside mm	Installed in Component
N3	610.000	270.0	47.62	0.00	Cylinder
N2	400.000	270.0	74.00	0.00	Cylinder
Noz N1	...	0.0	72.00	0.00	Right Cap

PV Elite is a trademark of Hexagon AB, 2022, All rights reserved.

Pulsation damper inlet

C220006CLC007

Static calculation

PV Elite 24 SP1 Licensee: PPV-Engineering B.V.

FileName : Instrument air inlet_LI4731 -----

Bill of Material: Step: 11 9:22am Jun 21,2022

Bill of Materials:

QTY	DESCRIPTION	MATERIAL
2	ELLIPTICAL HEAD: 2.0 X 1, 8.2mm THK X 202.7mm ID X 51.3mm	SA-234 WPB
1	CYLINDER: 8.2mm THK X 204.8mm ID X 760.0mm	SA-106 B
1	NAMEPLATE	...

PV Elite is a trademark of Hexagon AB, 2022, All rights reserved.

Pulsation damper inlet

C220006CLC007

Static calculation

PV Elite 24 SP1 Licensee: PPV-Engineering B.V.

FileName : Instrument air inlet_LI4731 -----

Input Echo: Step: 1 9:22am Jun 21, 2022

Units used in this Analysis (SI_ASME):

Name	System Unit	Constant	User Unit
Length	Feet	304.8000	mm
Force	Pounds	4.4480	N
Mass	Pounds	0.4536	kgm
Area	sq. inches	645.1600	mm ²
Moment	ft. lbs.	1356.3000	N-mm
Stress	lbs./sq.in.	0.0069	MPa
Temperature	Degrees F	0.5556	°C
Pressure	psig	0.0069	MPa
Elast. Modulus	lbs./sq.in.	0.0069	MPa
Pipe Density	lbs./cu.in.	0.0277	kg/cm ³
Ins. Density	lbs./cu.ft.	0.1602E-04	kg/cm ³
Fluid Density	lbs./cu.ft.	0.1602E-04	kg/cm ³
Wind Speed	miles/hr	1.6093	km/hr
Tray Weight	lbs./sq.ft.	0.0005	kg/cm ²
Inertia	in.**4	416231.0000	mm**4
G Load	G's	1.0000	g's
Wind Load	lbs./sq.ft.	0.0479	kPa
Elevation	Feet	304.8000	mm
Volume	in.**3	0.0164	ltr
Diameter	inches	25.4000	mm
Thickness	inches	25.4000	mm

PV Elite Vessel Analysis Program: Input Data

Pulsation damper inlet

C220006CLC007

Static calculation

Design Internal Pressure (for Hydrotest)	1.25	MPa
Design Internal Temperature	85.0	°C
Projection of Nozzle from Vessel Top	0	mm
Projection of Nozzle from Vessel Bottom	0	mm
Minimum Design Metal Temperature	-28.9	°C
Type of Construction	Welded	
Special Service	None	
Degree of Radiography	RT-3	
Use Higher Longitudinal Stresses (Flag)	Y	
Select t for Internal Pressure (Flag)	N	
Select t for External Pressure (Flag)	N	
Select t for Axial Stress (Flag)	N	
Select Location for Stiff. Rings (Flag)	N	
Consider Vortex Shedding	N	

Shop Pressure Test:

Type of Pressure Test	User Entered Pressure
Pressure Test Position	Horizontal

Load Case 1	NP+EW+WI+FW+BW
Load Case 2	NP+EW+EE+FS+BS
Load Case 3	NP+OW+WI+FW+BW
Load Case 4	NP+OW+EQ+FS+BS
Load Case 5	NP+HW+HI
Load Case 6	NP+HW+HE

Pulsation damper inlet

C220006CLC007

Static calculation

PV Elite 24 SP1 Licensee: PPV-Engineering B.V.

FileName : Instrument air inlet_LI4731 -----

Input Echo: Step: 1 9:22am Jun 21, 2022

Load Case 7	IP+OW+WI+FW+BW
Load Case 8	IP+OW+EQ+FS+BS
Load Case 9	EP+OW+WI+FW+BW
Load Case 10	EP+OW+EQ+FS+BS
Load Case 11	HP+HW+HI
Load Case 12	HP+HW+HE
Load Case 13	IP+WE+EW
Load Case 14	IP+WF+CW
Load Case 15	IP+VO+OW
Load Case 16	IP+VE+EW
Load Case 17	NP+VO+OW
Load Case 18	FS+BS+IP+OW
Load Case 19	FS+BS+EP+OW

Wind Design Code No Wind Loads

Seismic Design Code No Seismic

Design Pressure + Static Head	Y
Consider MAP New and Cold in Noz. Design	N
Consider External Loads for Nozzle Des.	Y
Use ASME VIII-1 Appendix 1-9	N

Perform Blast Load Analysis	No
Material Database Year	Current w/Addenda or Code Year

Configuration Directives:

Do not use Nozzle MDMT Interpretation VIII-1 01-37	No
Use Table G instead of exact equation for "A"	Yes
Shell Head Joints are Tapered	Yes
Compute "K" in corroded condition	Yes
Use Code Case 2286	No
Use the MAWP to compute the MDMT	Yes
For thickness ratios ≤ 0.35 , MDMT will be -155F (-104C)	Yes
For PWHT & P1 Materials the MDMT can be $< -55F (-48C)$	No
Using Metric Material Databases, ASME II D	No
Calculate B31.3 type stress for Nozzles with Loads	Yes
Reduce the MDMT due to lower membrane stress	Yes
Consider Longitudinal Stress in MDMT Calculations	Yes

Complete Listing of Vessel Elements and Details:

Element From Node	10
Element To Node	20
Element Type	Elliptical
Description	Left Head
Distance "FROM" to "TO"	51.315 mm
Element Outside Diameter	219.1 mm
Element Thickness	8.18 mm
Internal Corrosion Allowance	3 mm
Nominal Thickness	8.18 mm
External Corrosion Allowance	0 mm
Design Internal Pressure	1.25 MPa
Design Temperature Internal Pressure	85 °C
Design External Pressure	0 MPa
Design Temperature External Pressure	85 °C
Effective Diameter Multiplier	1.2

Pulsation damper inlet
C220006CLC007

Static calculation

PV Elite 24 SP1 Licensee: PPV-Engineering B.V.

FileName : Instrument air inlet_LI4731 -----

Input Echo: Step: 1 9:22am Jun 21,2022

Material Name	SA-234 WPB	
Allowable Stress, Ambient	117.9	MPa
Allowable Stress, Operating	117.9	MPa
Allowable Stress, Hydrotest	153.28	MPa
Material Density	0.00775	kg/cm ³
P Number Thickness	30.988	mm
Yield Stress, Operating	222.99	MPa
UCS-66 Chart Curve Designation	B	
External Pressure Chart Name	CS-2	
UNS Number	K03006	
Product Form	Smls. & wld. fittings	
Efficiency, Longitudinal Seam	0.85	
Efficiency, Circumferential Seam	0.85	
Elliptical Head Factor	2.0	
Weld is pre-Heated	No	

Element From Node	20	
Element To Node	30	
Element Type	Cylinder	
Description	Cylinder	
Distance "FROM" to "TO"	760	mm
Element Outside Diameter	219.1	mm
Element Thickness	7.16	mm
Internal Corrosion Allowance	3	mm
Nominal Thickness	8.18	mm
External Corrosion Allowance	0	mm
Design Internal Pressure	1.25	MPa
Design Temperature Internal Pressure	85	°C
Design External Pressure	0	MPa
Design Temperature External Pressure	85	°C
Effective Diameter Multiplier	1.2	
Material Name	SA-106 B	
Allowable Stress, Ambient	117.9	MPa
Allowable Stress, Operating	117.9	MPa
Allowable Stress, Hydrotest	153.28	MPa
Material Density	0.00775	kg/cm ³
P Number Thickness	30.988	mm
Yield Stress, Operating	222.99	MPa
UCS-66 Chart Curve Designation	B	
External Pressure Chart Name	CS-2	
UNS Number	K03006	
Product Form	Smls. pipe	
Efficiency, Longitudinal Seam	0.85	
Efficiency, Circumferential Seam	0.85	
Weld is pre-Heated	No	

Element From Node	20	
Detail Type	Nozzle	
Detail ID	N2	
Dist. from "FROM" Node / Offset dist	400	mm
Nozzle Diameter	50	mm
Nozzle Schedule	160	
Nozzle Class	150	
Layout Angle	270.0	
Blind Flange (Y/N)	N	
Weight of Nozzle (Used if > 0)	0	N
Grade of Attached Flange	GR 1.1	

Pulsation damper inlet

C220006CLC007

Static calculation

PV Elite 24 SP1 Licensee: PPV-Engineering B.V.

FileName : Instrument air inlet_LI4731 -----

Input Echo: Step: 1 9:22am Jun 21,2022

```

Nozzle Matl                SA-106 B
Element From Node          20
Detail Type                 Nozzle
Detail ID                   N3
Dist. from "FROM" Node / Offset dist  610 mm
Nozzle Diameter            38.1 mm
Nozzle Schedule            None
Nozzle Class                None
Layout Angle                270.0
Blind Flange (Y/N)         N
Weight of Nozzle ( Used if > 0 )      0 N
Grade of Attached Flange    None
Nozzle Matl                SA-106 B
    
```

```

-----
Element From Node          30
Element To Node            40
Element Type                Elliptical
Description                 Right Cap
Distance "FROM" to "TO"    51.315 mm
Element Outside Diameter    219.1 mm
Element Thickness           8.18 mm
Internal Corrosion Allowance 3 mm
Nominal Thickness           8.18 mm
External Corrosion Allowance 0 mm
Design Internal Pressure    1.25 MPa
Design Temperature Internal Pressure 85 °C
Design External Pressure    0 MPa
Design Temperature External Pressure 85 °C
Effective Diameter Multiplier 1.2
Material Name               SA-234 WPB
    Allowable Stress, Ambient 117.9 MPa
    Allowable Stress, Operating 117.9 MPa
    Allowable Stress, Hydrotest 153.28 MPa
    Material Density          0.00775 kg/cm³
    P Number Thickness        30.988 mm
    Yield Stress, Operating   222.99 MPa
    UCS-66 Chart Curve Designation B
    External Pressure Chart Name CS-2
    UNS Number                K03006
    Product Form               Smls. & wld. fittings
Efficiency, Longitudinal Seam 0.85
Efficiency, Circumferential Seam 0.85
Elliptical Head Factor      2.0
Weld is pre-Heated         No
    
```

```

Element From Node          30
Detail Type                 Nozzle
Detail ID                   Noz N1
Dist. from "FROM" Node / Offset dist  0 mm
Nozzle Diameter            50 mm
Nozzle Schedule            160
Nozzle Class                150
Layout Angle                0.0
Blind Flange (Y/N)         N
Weight of Nozzle ( Used if > 0 )      0 N
Grade of Attached Flange    GR 1.1
    
```

Pulsation damper inlet
C220006CLC007

Static calculation

PV Elite 24 SP1 Licensee: PPV-Engineering B.V.

FileName : Instrument air inlet_LI4731 -----

Input Echo: Step: 1 9:22am Jun 21,2022

Nozzle Mat1

SA-106 B

PV Elite is a trademark of Hexagon AB, 2022, All rights reserved.

Pulsation damper inlet
C220006CLC007

Static calculation

PV Elite 24 SP1 Licensee: PPV-Engineering B.V.

FileName : Instrument air inlet_LI4731

Internal Pressure Calculations: Step: 3 9:22am Jun 21, 2022

Internal Pressure Results Summary:

Element Thickness, Pressure, Diameter and Allowable Stress :

From	To	Int. Press + Liq. Hd MPa	Nominal Thickness mm	Total Corr Allowance mm	Element Diameter mm	Allowable Stress(SE) MPa
Left Head		1.25	8.18	3	219.1	100.22
Cylinder		1.25	8.18	3	219.1	100.22
Right Cap		1.25	8.18	3	219.1	100.22

Element Required Thickness and MAWP :

From	To	Design Pressure MPa	M.A.W.P. Corroded MPa	M.A.P. New & Cold MPa	Minimum Thickness mm	Required Thickness mm
Left Head		1.25	4.83	8.022	8.18	4.5
Cylinder		1.25	3.864	6.726	7.16	4.5
Right Cap		1.25	4.83	8.022	8.18	4.5
Minimum			1.815	1.96		

Note : The M.A.W.P is Governed by a Standard Flange !

Note : The M.A.P.(NC) is Governed by a Flange !

Elements Suitable for Design Internal Pressure.

Internal Pressure Calculation Results:

ASME Code, Section VIII Division 1, 2021

Elliptical Head From 10 To 20 SA-234 WPB , UCS-66 Crv. B at 85 °C

Left Head

Longitudinal Joint: User Defined

Material UNS Number: K03006

Required Thickness due to Internal Pressure [tr]:

$$\begin{aligned}
 &= (P \cdot D_o \cdot K_{cor}) / (2 \cdot S \cdot E + 2 \cdot P \cdot (K_{cor} - 0.1)) \text{ per Appendix 1-4 (c)} \\
 &= (1.25 \cdot 219.1 \cdot 0.963) / (2 \cdot 117.9 \cdot 0.85 + 2 \cdot 1.25 \cdot (0.963 - 0.1)) \\
 &= 1.3022 + 3.0000 = 4.3022 \text{ mm}
 \end{aligned}$$

Note: The thickness required was less than the Code Minimum, therefore the Code Minimum value of 1.5000 mm per UG-16 will be used.

Max. Allowable Working Pressure at given Thickness, corroded [MAWP]:

$$\begin{aligned}
 &= (2 \cdot S \cdot E \cdot t) / (K_{cor} \cdot D_o - 2 \cdot t \cdot (K_{cor} - 0.1)) \text{ per Appendix 1-4 (c)} \\
 &= (2 \cdot 117.9 \cdot 0.85 \cdot 5.18) / (0.963 \cdot 219.1 - 2 \cdot 5.18 \cdot (0.963 - 0.1)) \\
 &= 5.137 \text{ MPa}
 \end{aligned}$$

Maximum Allowable Pressure, New and Cold [MAPNC]:

$$= (2 \cdot S \cdot E \cdot t) / (K \cdot D_o - 2 \cdot t \cdot (K - 0.1)) \text{ per Appendix 1-4 (c)}$$

Pulsation damper inlet
C220006CLC007

Static calculation

PV Elite 24 SP1 Licensee: PPV-Engineering B.V.

FileName : Instrument air inlet_LI4731 -----

Internal Pressure Calculations: Step: 3 9:22am Jun 21, 2022

$$= (2 \cdot 117.9 \cdot 0.85 \cdot 8.18) / (1 \cdot 219.1 - 2 \cdot 8.18 \cdot (1 - 0.1))$$

$$= 8.022 \text{ MPa}$$

Actual stress at given pressure and thickness, corroded [Sact]:

$$= (P \cdot (K_{cor} \cdot D_o - 2 \cdot t \cdot (K_{cor} - 0.1))) / (2 \cdot E \cdot t)$$

$$= (1.25 \cdot (0.963 \cdot 219.1 - 2 \cdot 5.18 \cdot (0.963 - 0.1))) / (2 \cdot 0.85 \cdot 5.18)$$

$$= 28.689 \text{ MPa}$$

Straight Flange Required Thickness:

$$= (P \cdot R_o) / (S \cdot E + 0.4 \cdot P) + c_a \text{ per Appendix 1-1 (a)(1)}$$

$$= (1.25 \cdot 109.5) / (117.9 \cdot 0.85 + 0.4 \cdot 1.25) + 3$$

$$= 4.360 \text{ mm}$$

Straight Flange Maximum Allowable Working Pressure:

$$= (S \cdot E \cdot t) / (R_o - 0.4 \cdot t) \text{ per Appendix 1-1 (a)(1)}$$

$$= (117.9 \cdot 0.85 \cdot 5.18) / (109.5 - 0.4 \cdot 5.18)$$

$$= 4.83 \text{ MPa}$$

Factor K, corroded condition [Kcor]:

$$= (2 + (\text{Inside Diameter} / (2 \cdot \text{Inside Head Depth}))^2) / 6$$

$$= (2 + (208.7 / (2 \cdot 53.68))^2) / 6$$

$$= 0.963266$$

MDMT Calculations in the Knuckle Portion:

Govrn. thk, tg = 8.18, tr = 1.882, c = 3 mm, E* = 0.85

Thickness Ratio = tr * E* / (tg - c) = 0.309, Temp. Reduction = 78 °C

Min Metal Temp. w/o impact per UCS-66, Curve B	-29 °C
Min Metal Temp. at Required thickness (UCS 66.1)	-104 °C

MDMT Calculations in the Head Straight Flange:

Govrn. thk, tg = 8.18, tr = 1.97, c = 3 mm, E* = 0.85

Thickness Ratio = tr * E* / (tg - c) = 0.323, Temp. Reduction = 78 °C

Min Metal Temp. w/o impact per UCS-66, Curve B	-29 °C
Min Metal Temp. at Required thickness (UCS 66.1)	-104 °C

Cylindrical Shell From 20 To 30 SA-106 B , UCS-66 Crv. B at 85 °C

Cylinder

Longitudinal Joint: Spot Radiography per UW-11(b) Type 1

Material UNS Number: K03006

Required Thickness due to Internal Pressure [tr]:

$$= (P \cdot R_o) / (S \cdot E + 0.4 \cdot P) \text{ per Appendix 1-1 (a)(1)}$$

$$= (1.25 \cdot 109.5) / (117.9 \cdot 0.85 + 0.4 \cdot 1.25)$$

$$= 1.3596 + 3.0000 = 4.3596 \text{ mm}$$

Note: The thickness required was less than the Code Minimum, therefore the Code Minimum value of 1.5000 mm per UG-16 will be used.

Max. Allowable Working Pressure at given Thickness, corroded [MAWP]:

$$= (S \cdot E \cdot t) / (R_o - 0.4 \cdot t) \text{ per Appendix 1-1 (a)(1)}$$

$$= (117.9 \cdot 0.85 \cdot 4.16) / (109.5 - 0.4 \cdot 4.16)$$

$$= 3.864 \text{ MPa}$$

Pulsation damper inlet
C220006CLC007

Static calculation

PV Elite 24 SP1 Licensee: PPV-Engineering B.V.

FileName : Instrument air inlet_LI4731 -----

Internal Pressure Calculations: Step: 3 9:22am Jun 21, 2022

Maximum Allowable Pressure, New and Cold [MAPNC]:

$$= (S \cdot E \cdot t) / (R_o - 0.4 \cdot t) \text{ per Appendix 1-1 (a)(1)}$$

$$= (117.9 \cdot 0.85 \cdot 7.16) / (109.5 - 0.4 \cdot 7.16)$$

$$= 6.726 \text{ MPa}$$

Actual stress at given pressure and thickness, corroded [Sact]:

$$= (P \cdot (R_o - 0.4 \cdot t)) / (E \cdot t)$$

$$= (1.25 \cdot ((109.5 - 0.4 \cdot 4.16)) / (0.85 \cdot 4.16))$$

$$= 38.138 \text{ MPa}$$

Minimum Design Metal Temperature Results:

Govrn. thk, tg = 7.16, tr = 0.951, c = 3 mm, E* = 0.85

Thickness Ratio = tr * E* / (tg - c) = 0.194, Temp. Reduction = 78 °C

Min Metal Temp. w/o impact per UCS-66, Curve B -29 °C

Min Metal Temp. at Required thickness (UCS 66.1) -104 °C

Elliptical Head From 30 To 40 SA-234 WPB , UCS-66 Crv. B at 85 °C

Right Cap

Longitudinal Joint: User Defined

Material UNS Number: K03006

Required Thickness due to Internal Pressure [tr]:

$$= (P \cdot D_o \cdot K_{cor}) / (2 \cdot S \cdot E + 2 \cdot P \cdot (K_{cor} - 0.1)) \text{ per Appendix 1-4 (c)}$$

$$= (1.25 \cdot 219.1 \cdot 0.963) / (2 \cdot 117.9 \cdot 0.85 + 2 \cdot 1.25 \cdot (0.963 - 0.1))$$

$$= 1.3022 + 3.0000 = 4.3022 \text{ mm}$$

Note: The thickness required was less than the Code Minimum, therefore the Code Minimum value of 1.5000 mm per UG-16 will be used.

Max. Allowable Working Pressure at given Thickness, corroded [MAWP]:

$$= (2 \cdot S \cdot E \cdot t) / (K_{cor} \cdot D_o - 2 \cdot t \cdot (K_{cor} - 0.1)) \text{ per Appendix 1-4 (c)}$$

$$= (2 \cdot 117.9 \cdot 0.85 \cdot 5.18) / (0.963 \cdot 219.1 - 2 \cdot 5.18 \cdot (0.963 - 0.1))$$

$$= 5.137 \text{ MPa}$$

Maximum Allowable Pressure, New and Cold [MAPNC]:

$$= (2 \cdot S \cdot E \cdot t) / (K \cdot D_o - 2 \cdot t \cdot (K - 0.1)) \text{ per Appendix 1-4 (c)}$$

$$= (2 \cdot 117.9 \cdot 0.85 \cdot 8.18) / (1 \cdot 219.1 - 2 \cdot 8.18 \cdot (1 - 0.1))$$

$$= 8.022 \text{ MPa}$$

Actual stress at given pressure and thickness, corroded [Sact]:

$$= (P \cdot (K_{cor} \cdot D_o - 2 \cdot t \cdot (K_{cor} - 0.1))) / (2 \cdot E \cdot t)$$

$$= (1.25 \cdot (0.963 \cdot 219.1 - 2 \cdot 5.18 \cdot (0.963 - 0.1))) / (2 \cdot 0.85 \cdot 5.18)$$

$$= 28.689 \text{ MPa}$$

Straight Flange Required Thickness:

$$= (P \cdot R_o) / (S \cdot E + 0.4 \cdot P) + c_a \text{ per Appendix 1-1 (a)(1)}$$

$$= (1.25 \cdot 109.5) / (117.9 \cdot 0.85 + 0.4 \cdot 1.25) + 3$$

$$= 4.360 \text{ mm}$$

Straight Flange Maximum Allowable Working Pressure:

$$= (S \cdot E \cdot t) / (R_o - 0.4 \cdot t) \text{ per Appendix 1-1 (a)(1)}$$

$$= (117.9 \cdot 0.85 \cdot 5.18) / (109.5 - 0.4 \cdot 5.18)$$

$$= 4.83 \text{ MPa}$$

Pulsation damper inlet
C220006CLC007

Static calculation

PV Elite 24 SP1 Licensee: PPV-Engineering B.V.

FileName : Instrument air inlet_LI4731 -----

Internal Pressure Calculations: Step: 3 9:22am Jun 21, 2022

Factor K, corroded condition [Kcor]:

$$= (2 + (\text{Inside Diameter} / (2 * \text{Inside Head Depth}))^2) / 6$$

$$= (2 + (208.7 / (2 * 53.68))^2) / 6$$

$$= 0.963266$$

MDMT Calculations in the Knuckle Portion:

Govrn. thk, tg = 8.18, tr = 1.882, c = 3 mm, E* = 0.85
Thickness Ratio = tr * E*/(tg - c) = 0.309, Temp. Reduction = 78 °C

Min Metal Temp. w/o impact per UCS-66, Curve B -29 °C
Min Metal Temp. at Required thickness (UCS 66.1) -104 °C

MDMT Calculations in the Head Straight Flange:

Govrn. thk, tg = 8.18, tr = 1.97, c = 3 mm, E* = 0.85
Thickness Ratio = tr * E*/(tg - c) = 0.323, Temp. Reduction = 78 °C

Min Metal Temp. w/o impact per UCS-66, Curve B -29 °C
Min Metal Temp. at Required thickness (UCS 66.1) -104 °C

Note: Heads and Shells Exempted to -20F (-29C) by paragraph UG-20F

Hydrostatic Test Pressure Results:

Pressure per UG99b	= 1.30 * M.A.W.P. * Sa/S	2.360 MPa
Pressure per UG99b[35]	= 1.30 * Design Pres * Sa/S	1.625 MPa
Pressure per UG99c	= 1.30 * M.A.P. - Head(Hyd)	2.548 MPa
Pressure per UG100	= 1.10 * M.A.W.P. * Sa/S	1.997 MPa
Pressure per PED	= max(1.43*DP, 1.25*DP*ratio)	1.787 MPa
Pressure per App 27-4	= M.A.W.P.	1.815 MPa
User Defined Hydrostatic Test Pressure at High Point		2.550 MPa

Horizontal Test performed per: User Hydro Pressure

Please note that Nozzle, Shell, Head, Flange, etc MAWPs are all considered when determining the hydrotest pressure for those test types that are based on the MAWP of the vessel.

Stresses on Elements due to Test Pressure (MPa):

From To	Stress	Allowable	Ratio	Pressure
Left Head	37.5	153.3	0.245	2.55
Cylinder	44.7	153.3	0.292	2.55
Right Cap	37.5	153.3	0.245	2.55

Stress ratios for Nozzle and Pad Materials (MPa):

Description	Pad/Nozzle	Ambient	Operating	Ratio
N2	Nozzle	117.90	117.90	1.000
N3	Nozzle	117.90	117.90	1.000
Noz N1	Nozzle	117.90	117.90	1.000

Pulsation damper inlet
 C220006CLC007

Static calculation

PV Elite 24 SP1 Licensee: PPV-Engineering B.V.

FileName : Instrument air inlet_LI4731 -----

Internal Pressure Calculations: Step: 3 9:22am Jun 21,2022

Minimum 1.000

Stress ratios for Pressurized Vessel Elements (MPa):

Description	Ambient	Operating	Ratio
Left Head	117.90	117.90	1.000
Cylinder	117.90	117.90	1.000
Right Cap	117.90	117.90	1.000
Minimum			1.000

Hoop Stress in Nozzle Wall during Pressure Test (MPa):

Description	Ambient	Operating	Ratio
N2	7.79	153.28	0.051
N3	4.78	153.28	0.031
Noz N1	7.79	153.28	0.051

Elements Suitable for Test Pressure.

PV Elite is a trademark of Hexagon AB, 2022, All rights reserved.

Pulsation damper inlet
C220006CLC007

Static calculation

PV Elite 24 SP1 Licensee: PPV-Engineering B.V.

FileName : Instrument air inlet_LI4731 -----

Element and Detail Weights: Step: 5 9:22am Jun 21,2022

Element and Detail Weights:

From	To	Element Metal Wgt. kgm	Element ID Volume ltr	Corroded Metal Wgt. kgm	Corroded ID Volume ltr	Extra due Misc % kgm
10	20	5.5314	2.7479	3.50277	2.94718	...
20	30	32.2363	25.0355	20.7012	26.5241	...
30	40	5.5314	2.7479	3.50277	2.94718	...
Total		43	30.53	27	32.42	0

Weight of Details:

From	Type	Weight of Detail kgm	X Offset, Dtl. Cent. mm	Y Offset, Dtl. Cent. mm	Z Offset Dtl. Cent. mm	Description
20	Noz1	4.14184	400	-132.552	...	N2
20	Noz1	0.28886	610	-121.44	...	N3
30	Noz1	4.1201	102	Noz N1

Total Weight of Each Detail Type:

Nozzles	8.6

Sum of the Detail Weights	8.6 kgm

Weight Summation Results: (kgm)

	Fabricated	Shop Test	Shipping	Erected	Empty	Operating
Main Elements	43.3	43.3	43.3	43.3	43.3	43.3
Nozzles	8.6	8.6	8.6	8.6	8.6	8.6
Test Liquid	...	30.5
Totals	51.8	82.4	51.8	51.8	51.8	51.8

Weight Summary:

Fabricated Wt.	- Bare Weight without Removable Internals	51.8 kgm
Shop Test Wt.	- Fabricated Weight + Water (Full)	82.4 kgm
Shipping Wt.	- Fab. Wt + removable Intls.+ Shipping App.	51.8 kgm
Erected Wt.	- Fab. Wt + or - loose items (trays,platforms etc.)	51.8 kgm
Ope. Wt. no Liq	- Fab. Weight + Internals. + Details + Weights	51.8 kgm
Operating Wt.	- Empty Weight + Operating Liq. Uncorroded	51.8 kgm
Oper. Wt. + CA	- Corr Wt. + Operating Liquid	36.3 kgm
Field Test Wt.	- Empty Weight + Water (Full)	82.4 kgm

Note:

The Corroded Weight and thickness are used in the Horizontal Vessel Analysis (Ope Case) and Earthquake Load Calculations.

Outside Surface Areas of Elements:

From	To	Surface Area
------	----	-----------------

Pulsation damper inlet

C220006CLC007

Static calculation

PV Elite 24 SP1 Licensee: PPV-Engineering B.V.

FileName : Instrument air inlet_LI4731 -----

Element and Detail Weights: Step: 5 9:22am Jun 21,2022

		mm ²
10	20	87357.8
20	30	527996
30	40	87357.8
Total		702711.750 mm ²

PV Elite is a trademark of Hexagon AB, 2022, All rights reserved.

Pulsation damper inlet
 C220006CLC007

Static calculation

PV Elite 24 SP1 Licensee: PPV-Engineering B.V.

FileName : Instrument air inlet_LI4731 -----

Nozzle Flange MAWP: Step: 6 9:22am Jun 21,2022

Nozzle Flange MAWP Results: (MPa & °C)

Nozzle Description	Flange Rating		Design Temp	Class	Grade/Group	Equiv. Press	Max Pressure		
	Op.	Ambient					UG-44(b)	50%	DNV
N2	1.82	1.96	85	150	GR 1.1
Noz N1	1.82	1.96	85	150	GR 1.1
Min Rating	1.815	1.960 MPa [for Core Elements]				

Pressure Ratings are per ASME B16.5 2017 Metric Edition

PV Elite is a trademark of Hexagon AB, 2022, All rights reserved.

Pulsation damper inlet
C220006CLC007

Static calculation

PV Elite 24 SP1 Licensee: PPV-Engineering B.V.

FileName : Instrument air inlet_LI4731 -----

Nozzle Calcs.: N2 Nozl: 13 9:22am Jun 21,2022

Input, Nozzle Desc: N2

From: 20

Pressure for Reinforcement Calculations	P	1.2500	MPa
Temperature for Internal Pressure	Temp	85	°C
Parent Material		SA-106 B	
Parent Allowable Stress at Temperature	Sv	117.90	MPa
Parent Allowable Stress At Ambient	Sva	117.90	MPa
Inside Diameter of Cylindrical Shell	D	202.74	mm
Shell Finished (Minimum) Thickness	t	7.1600	mm
Shell Internal Corrosion Allowance	c	3.0000	mm
Shell External Corrosion Allowance	co	0.0000	mm
Distance from Bottom/Left Tangent		451.31	mm
User Entered Minimum Design Metal Temperature		-28.89	°C

Type of Element Connected to the Parent : Nozzle

Material		SA-106 B	
Material UNS Number		K03006	
Material Specification/Type		Smls. pipe	
Allowable Stress at Temperature	Sn	117.90	MPa
Allowable Stress At Ambient	Sna	117.90	MPa
Diameter Basis (for tr calc only)		Outside	
Layout Angle		270.00	deg
Diameter		50.0000	mm
Size and Thickness Basis		Nominal	
Nominal Thickness		160	
Flange Material		SA-105	
Flange Type		Weld Neck Flange	
Corrosion Allowance	can	3.0000	mm
Joint Efficiency of Shell Seam at Nozzle	E1	1.00	
Joint Efficiency of Nozzle Neck	En	1.00	
Outside Projection	ho	74.0000	mm
Weld leg size between Nozzle and Pad/Shell	Wo	6.0000	mm
Groove weld depth between Nozzle and Vessel Wgnv		8.3400	mm
Flange Class		150	
Flange Grade		GR 1.1	

The Pressure Design option was Design Pressure + static head.

Nozzle Sketch (may not represent actual weld type/configuration)

Pulsation damper inlet

C220006CLC007

Static calculation

PV Elite 24 SP1 Licensee: PPV-Engineering B.V.

FileName : Instrument air inlet_LI4731 -----

Nozzle Calcs.: N2

Nozl: 13 9:22am Jun 21,2022

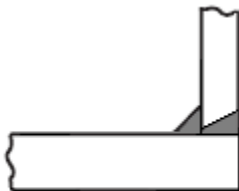
**Abutting/Set-on Nozzle No Pad****Reinforcement CALCULATION, Description: N2**

ASME Code, Section VIII, Div. 1, 2021, UG-37 to UG-45

Actual Outside Diameter Used in Calculation	60.325 mm.
Actual Thickness Used in Calculation	8.738 mm

Nozzle input data check completed without errors.

Reqd thk per UG-37(a) of Cylindrical Shell, tr [Int. Press]

$$= P \cdot R / (S_v \cdot E - 0.6 \cdot P) \text{ per UG-27 (c)(1)}$$

$$= 1.25 \cdot 104.4 / (117.9 \cdot 1 - 0.6 \cdot 1.25)$$

$$= 1.1136 \text{ mm}$$

Reqd thk per UG-37(a) of Nozzle Wall, trn [Int. Press]

$$= P \cdot R_o / (S_n \cdot E + 0.4 \cdot P) \text{ per Appendix 1-1 (a)(1)}$$

$$= 1.25 \cdot 30.16 / (117.9 \cdot 1 + 0.4 \cdot 1.25)$$

$$= 0.3184 \text{ mm}$$

UG-40, Limits of Reinforcement : [Internal Pressure]

Parallel to Vessel Wall (Diameter Limit)	D1	97.6996 mm
Parallel to Vessel Wall, opening length	d	48.8498 mm
Normal to Vessel Wall (Thickness Limit), no pad	Tlnp	10.4000 mm

Taking a UG-36(c)(3)(a) exemption for nozzle: N2.

This calculation is valid for nozzles that meet all the requirements of paragraph UG-36. Please check the Code carefully, especially for nozzles that are not isolated or do not meet Code spacing requirements. To force the computation of areas for small nozzles go to Tools->Configuration and check the box to force the UG-37 small nozzle area calculation.

UG-45 Minimum Nozzle Neck Thickness Requirement: [Int. Press.]

Wall Thickness for Internal/External pressures	ta = 3.3184 mm
Wall Thickness per UG16(b),	tr16b = 4.5000 mm
Wall Thickness, shell/head, internal pressure	trb1 = 4.1136 mm
Wall Thickness	tb1 = max(trb1, tr16b) = 4.5000 mm
Wall Thickness	tb2 = max(trb2, tr16b) = 4.5000 mm
Wall Thickness per table UG-45	tb3 = 6.4200 mm

Determine Nozzle Thickness candidate [tb]:

$$= \min[tb3, \max(tb1, tb2)]$$

$$= \min[6.42, \max(4.5, 4.5)]$$

$$= 4.5000 \text{ mm}$$

Minimum Wall Thickness of Nozzle Necks [tUG-45]:

$$= \max(ta, tb)$$

Pulsation damper inlet
C220006CLC007

Static calculation

PV Elite 24 SP1 Licensee: PPV-Engineering B.V.

FileName : Instrument air inlet_LI4731 -----

Nozzle Calcs.: N2 Nozl: 13 9:22am Jun 21, 2022

$$= \max(3.318, 4.5)$$

$$= 4.5000 \text{ mm}$$

Available Nozzle Neck Thickness = $0.875 * 8.738 = 7.645 \text{ mm}$ --> OK

Nozzle Junction Minimum Design Metal Temperature (MDMT) Calculations:

Nozzle Neck to Flange Weld, min(Curve:B, Curve:A)

Govrn. thk, tg = 7.645, tr = 0.318, c = 3 mm, E* = 1
Thickness Ratio = $tr * E*/(tg - c) = 0.0685$, Temp. Reduction = 78 °C

Min Metal Temp. w/o impact per UCS-66, Curve A	-8 °C
Min Metal Temp. at Required thickness (UCS 66.1)	-104 °C
Min Metal Temp. w/o impact per UG-20(f)	-29 °C

Nozzle-Shell/Head Weld (UCS-66(a)1(b)), Curve: B

Govrn. thk, tg = 7.16, tr = 1.114, c = 3 mm, E* = 1
Thickness Ratio = $tr * E*/(tg - c) = 0.268$, Temp. Reduction = 78 °C

Min Metal Temp. w/o impact per UCS-66, Curve B	-29 °C
Min Metal Temp. at Required thickness (UCS 66.1)	-104 °C

Gov. MDMT of the nozzle to shell joint welded assembly : -104 °C

Flange MDMT including Temperature reduction per UCS-66.1:

Unadjusted MDMT of ASME B16.5/47 flanges per UCS-66(c)	-18 °C
Flange MDMT with Temp reduction per UCS-66(b)(1)(-b)	-38 °C

Where the Stress Reduction Ratio per UCS-66(b)(1)(-b) is :
Design Pressure/Ambient Rating = $1.25/1.96 = 0.638$

Weld Size Calculations, Description: N2

Intermediate Calc. for nozzle/shell Welds Tmin 5.1800 mm

Results Per UW-16.1:

	Required Thickness	Actual Thickness
Nozzle Weld	$3.6260 = 0.7 * t_{min}$	$4.2420 = 0.7 * W_o$ mm

Skipping the nozzle attachment weld strength calculations. Per UW-15(b)(2) the nozzles exempted by UG-36(c)(3)(a) (small nozzles) do not require a weld strength check.

Maximum Allowable Pressure for this Nozzle at this Location:

Converged Maximum Allowable Pressure in the Operating case: 3.864 MPa

Note: The MAWP of this junction was limited by the parent Shell/Head.

The Drop for this Nozzle is : 4.5914 mm
The Cut Length for this Nozzle is, Drop + Ho + H + T : 85.7514 mm

PV Elite is a trademark of Hexagon AB, 2022, All rights reserved.

Pulsation damper inlet
C220006CLC007

Static calculation

PV Elite 24 SP1 Licensee: PPV-Engineering B.V.

FileName : Instrument air inlet_LI4731 -----

Nozzle Calcs.: N3 Nozl: 14 9:22am Jun 21,2022

Input, Nozzle Desc: N3 From: 20

Pressure for Reinforcement Calculations	P	1.2500	MPa
Temperature for Internal Pressure	Temp	85	°C
Parent Material		SA-106 B	
Parent Allowable Stress at Temperature	Sv	117.90	MPa
Parent Allowable Stress At Ambient	Sva	117.90	MPa
Inside Diameter of Cylindrical Shell	D	202.74	mm
Shell Finished (Minimum) Thickness	t	7.1600	mm
Shell Internal Corrosion Allowance	c	3.0000	mm
Shell External Corrosion Allowance	co	0.0000	mm
Distance from Bottom/Left Tangent		661.31	mm
User Entered Minimum Design Metal Temperature		-28.89	°C

Type of Element Connected to the Parent : Nozzle

Material		SA-106 B	
Material UNS Number		K03006	
Material Specification/Type		Smls. pipe	
Allowable Stress at Temperature	Sn	117.90	MPa
Allowable Stress At Ambient	Sna	117.90	MPa
Diameter Basis (for tr calc only)		Outside	
Layout Angle		270.00	deg
Diameter		38.1000	mm
Size and Thickness Basis		Actual	
Actual Thickness	tn	8.3820	mm
Corrosion Allowance	can	3.0000	mm
Joint Efficiency of Shell Seam at Nozzle	E1	1.00	
Joint Efficiency of Nozzle Neck	En	1.00	
Outside Projection	ho	47.6250	mm
Weld leg size between Nozzle and Pad/Shell	Wo	6.0000	mm
Groove weld depth between Nozzle and Vessel Wgnv		8.3400	mm

The Pressure Design option was Design Pressure + static head.

Nozzle Sketch (may not represent actual weld type/configuration)

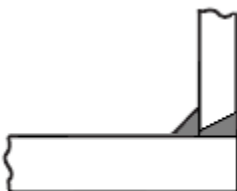

Abutting/Set-on Nozzle No Pad

Pulsation damper inlet
C220006CLC007

Static calculation

PV Elite 24 SP1 Licensee: PPV-Engineering B.V.

FileName : Instrument air inlet_LI4731 -----

Nozzle Calcs.: N3 Nozl: 14 9:22am Jun 21, 2022

Reinforcement CALCULATION, Description: N3

ASME Code, Section VIII, Div. 1, 2021, UG-37 to UG-45

Actual Outside Diameter Used in Calculation	38.100 mm.
Actual Thickness Used in Calculation	8.382 mm

Nozzle input data check completed without errors.

Reqd thk per UG-37(a) of Cylindrical Shell, tr [Int. Press]

$$= P \cdot R / (S_v \cdot E - 0.6 \cdot P) \text{ per UG-27 (c)(1)}$$

$$= 1.25 \cdot 104.4 / (117.9 \cdot 1 - 0.6 \cdot 1.25)$$

$$= 1.1136 \text{ mm}$$

Reqd thk per UG-37(a) of Nozzle Wall, trn [Int. Press]

$$= P \cdot R_o / (S_n \cdot E + 0.4 \cdot P) \text{ per Appendix 1-1 (a)(1)}$$

$$= 1.25 \cdot 19.05 / (117.9 \cdot 1 + 0.4 \cdot 1.25)$$

$$= 0.2011 \text{ mm}$$

UG-40, Limits of Reinforcement : [Internal Pressure]

Parallel to Vessel Wall (Diameter Limit)	D1	54.6720 mm
Parallel to Vessel Wall, opening length	d	27.3360 mm
Normal to Vessel Wall (Thickness Limit), no pad	Tlnp	10.4000 mm

Taking a UG-36(c)(3)(a) exemption for nozzle: N3.

This calculation is valid for nozzles that meet all the requirements of paragraph UG-36. Please check the Code carefully, especially for nozzles that are not isolated or do not meet Code spacing requirements. To force the computation of areas for small nozzles go to Tools->Configuration and check the box to force the UG-37 small nozzle area calculation.

UG-45 Minimum Nozzle Neck Thickness Requirement: [Int. Press.]

Wall Thickness for Internal/External pressures	ta = 3.2011 mm
Wall Thickness per UG16(b),	tr16b = 4.5000 mm
Wall Thickness, shell/head, internal pressure	trb1 = 4.1136 mm
Wall Thickness	tb1 = max(trb1, tr16b) = 4.5000 mm
Wall Thickness	tb2 = max(trb2, tr16b) = 4.5000 mm
Wall Thickness per table UG-45	tb3 = 6.1200 mm

Determine Nozzle Thickness candidate [tb]:

$$= \min[tb3, \max(tb1, tb2)]$$

$$= \min[6.12, \max(4.5, 4.5)]$$

$$= 4.5000 \text{ mm}$$

Minimum Wall Thickness of Nozzle Necks [tUG-45]:

$$= \max(ta, tb)$$

$$= \max(3.201, 4.5)$$

$$= 4.5000 \text{ mm}$$

Available Nozzle Neck Thickness = 8.3820 mm --> OK

Nozzle Junction Minimum Design Metal Temperature (MDMT) Calculations:

Nozzle-Shell/Head Weld (UCS-66(a)1(b)), Curve: B

Govrn. thk, tg = 7.16, tr = 1.114, c = 3 mm, E* = 1

Thickness Ratio = tr * E*/(tg - c) = 0.268, Temp. Reduction = 78 °C

Pulsation damper inlet

C220006CLC007

Static calculation

PV Elite 24 SP1 Licensee: PPV-Engineering B.V.

FileName : Instrument air inlet_LI4731 -----

Nozzle Calcs.: N3 Nozl: 14 9:22am Jun 21,2022

Min Metal Temp. w/o impact per UCS-66, Curve B -29 °C

Min Metal Temp. at Required thickness (UCS 66.1) -104 °C

Gov. MDMT of the nozzle to shell joint welded assembly : -104 °C

Weld Size Calculations, Description: N3

Intermediate Calc. for nozzle/shell Welds Tmin 5.1800 mm

Results Per UW-16.1:

	Required Thickness	Actual Thickness
Nozzle Weld	3.6260 = 0.7 * tmin.	4.2420 = 0.7 * Wo mm

Skipping the nozzle attachment weld strength calculations. Per UW-15(b)(2) the nozzles exempted by UG-36(c)(3)(a) (small nozzles) do not require a weld strength check.

Maximum Allowable Pressure for this Nozzle at this Location:

Converged Maximum Allowable Pressure in the Operating case: 3.864 MPa

Note: The MAWP of this junction was limited by the parent Shell/Head.

The Drop for this Nozzle is : 1.8061 mm

The Cut Length for this Nozzle is, Drop + Ho + H + T : 56.5911 mm

PV Elite is a trademark of Hexagon AB, 2022, All rights reserved.

Pulsation damper inlet
C220006CLC007

Static calculation

PV Elite 24 SP1 Licensee: PPV-Engineering B.V.

FileName : Instrument air inlet_LI4731 -----

Nozzle Calcs.: Noz N1 Nozl: 15 9:22am Jun 21, 2022

Input, Nozzle Desc: Noz N1

From: 30

Pressure for Reinforcement Calculations	P	1.2500	MPa
Temperature for Internal Pressure	Temp	85	°C
Parent Material		SA-234	WPB
Parent Allowable Stress at Temperature	Sv	117.90	MPa
Parent Allowable Stress At Ambient	Sva	117.90	MPa
Inside Diameter of Elliptical Head	D	202.74	mm
Aspect Ratio of Elliptical Head	Ar	2.00	
Head Finished (Minimum) Thickness	t	8.1800	mm
Head Internal Corrosion Allowance	c	3.0000	mm
Head External Corrosion Allowance	co	0.0000	mm
Distance from Head Centerline	L1	0.0000	mm
User Entered Minimum Design Metal Temperature		-28.89	°C

Type of Element Connected to the Parent : Nozzle

Material		SA-106	B
Material UNS Number		K03006	
Material Specification/Type		Smls.	pipe
Allowable Stress at Temperature	Sn	117.90	MPa
Allowable Stress At Ambient	Sna	117.90	MPa
Diameter Basis (for tr calc only)		Outside	
Layout Angle		0.00	deg
Diameter		50.0000	mm
Size and Thickness Basis		Nominal	
Nominal Thickness		160	
Flange Material		SA-105	
Flange Type		Weld Neck	Flange
Corrosion Allowance	can	3.0000	mm
Joint Efficiency of Shell Seam at Nozzle	E1	1.00	
Joint Efficiency of Nozzle Neck	En	1.00	
Outside Projection	ho	72.0000	mm
Weld leg size between Nozzle and Pad/Shell	Wo	6.0000	mm
Groove weld depth between Nozzle and Vessel Wgnv		7.1600	mm
Flange Class		150	
Flange Grade		GR 1.1	

The Pressure Design option was Design Pressure + static head.

Nozzle Sketch (may not represent actual weld type/configuration)

Pulsation damper inlet
 C220006CLC007
 Static calculation
 PV Elite 24 SP1 Licensee: PPV-Engineering B.V.
 FileName : Instrument air inlet_LI4731 -----
 Nozzle Calcs.: Noz N1 Nozl: 15 9:22am Jun 21,2022

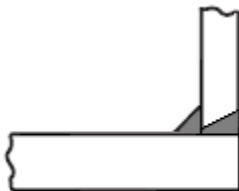

Abutting/Set-on Nozzle No Pad

Reinforcement CALCULATION, Description: Noz N1

ASME Code, Section VIII, Div. 1, 2021, UG-37 to UG-45

Actual Outside Diameter Used in Calculation 60.325 mm.
 Actual Thickness Used in Calculation 8.738 mm

Nozzle input data check completed without errors.

Reqd thk per UG-37(a) of Elliptical Head, tr [Int. Press]
 = $P \cdot D \cdot K1 / (2 \cdot Sv \cdot E - 0.2 \cdot P)$ per Appendix 1-4(c)
 = $0.876 \cdot 1.25 \cdot 208.7 / (2 \cdot 117.9 \cdot 1 - 0.2 \cdot 1.25)$
 = 0.9704 mm

Reqd thk per UG-37(a) of Nozzle Wall, trn [Int. Press]
 = $P \cdot Ro / (Sn \cdot E + 0.4 \cdot P)$ per Appendix 1-1 (a)(1)
 = $1.25 \cdot 30.16 / (117.9 \cdot 1 + 0.4 \cdot 1.25)$
 = 0.3184 mm

UG-40, Limits of Reinforcement : [Internal Pressure]

Parallel to Vessel Wall (Diameter Limit)	Dl	97.6996	mm
Parallel to Vessel Wall, opening length	d	48.8498	mm
Normal to Vessel Wall (Thickness Limit), no pad	Tlnp	12.9500	mm

*Taking a UG-36(c)(3)(a) exemption for nozzle: Noz N1.
 This calculation is valid for nozzles that meet all the requirements of paragraph UG-36. Please check the Code carefully, especially for nozzles that are not isolated or do not meet Code spacing requirements. To force the computation of areas for small nozzles go to Tools->Configuration and check the box to force the UG-37 small nozzle area calculation.*

UG-45 Minimum Nozzle Neck Thickness Requirement: [Int. Press.]

Wall Thickness for Internal/External pressures	ta	= 3.3184	mm
Wall Thickness per UG16(b),	tr16b	= 4.5000	mm
Wall Thickness, shell/head, internal pressure	trb1	= 4.0670	mm
Wall Thickness	tb1 = max(trb1, tr16b)	= 4.5000	mm
Wall Thickness	tb2 = max(trb2, tr16b)	= 4.5000	mm
Wall Thickness per table UG-45	tb3	= 6.4200	mm

Determine Nozzle Thickness candidate [tb]:
 = min[tb3, max(tb1, tb2)]
 = min[6.42, max(4.5, 4.5)]
 = 4.5000 mm

Minimum Wall Thickness of Nozzle Necks [tUG-45]:
 = max(ta, tb)

Pulsation damper inlet
C220006CLC007

Static calculation

PV Elite 24 SP1 Licensee: PPV-Engineering B.V.

FileName : Instrument air inlet_LI4731 -----

Nozzle Calcs.: Noz N1 Nozl: 15 9:22am Jun 21, 2022

$$= \max(3.318, 4.5)$$

$$= 4.5000 \text{ mm}$$

Available Nozzle Neck Thickness = $0.875 * 8.738 = 7.645 \text{ mm}$ --> OK

Nozzle Junction Minimum Design Metal Temperature (MDMT) Calculations:

Nozzle Neck to Flange Weld, Curve: B

Govrn. thk, tg = 7.645, tr = 0.318, c = 3 mm, E* = 1
Thickness Ratio = $tr * E*/(tg - c) = 0.0685$, Temp. Reduction = 78 °C

Min Metal Temp. w/o impact per UCS-66, Curve B	-29 °C
Min Metal Temp. at Required thickness (UCS 66.1)	-104 °C

Nozzle-Shell/Head Weld (UCS-66(a)1(b)), Curve: B

Govrn. thk, tg = 7.645, tr = 0.318, c = 3 mm, E* = 1
Thickness Ratio = $tr * E*/(tg - c) = 0.0685$, Temp. Reduction = 78 °C

Min Metal Temp. w/o impact per UCS-66, Curve B	-29 °C
Min Metal Temp. at Required thickness (UCS 66.1)	-104 °C

Gov. MDMT of the nozzle to shell joint welded assembly : -104 °C

Flange MDMT including Temperature reduction per UCS-66.1:

Unadjusted MDMT of ASME B16.5/47 flanges per UCS-66(c)	-18 °C
Flange MDMT with Temp reduction per UCS-66(b)(1)(-b)	-38 °C

Where the Stress Reduction Ratio per UCS-66(b)(1)(-b) is :
Design Pressure/Ambient Rating = $1.25/1.96 = 0.638$

Weld Size Calculations, Description: Noz N1

Intermediate Calc. for nozzle/shell Welds Tmin 5.1800 mm

Results Per UW-16.1:

	Required Thickness	Actual Thickness
Nozzle Weld	$3.6260 = 0.7 * t_{min}$	$4.2420 = 0.7 * W_o$ mm

Skipping the nozzle attachment weld strength calculations. Per UW-15(b)(2) the nozzles exempted by UG-36(c)(3)(a) (small nozzles) do not require a weld strength check.

Maximum Allowable Pressure for this Nozzle at this Location:

Converged Maximum Allowable Pressure in the Operating case: 4.83 MPa

Note: The MAWP of this junction was limited by the parent Shell/Head.

The Drop for this Nozzle is : 2.4222 mm
The Cut Length for this Nozzle is, Drop + Ho + H + T : 82.6022 mm

PV Elite is a trademark of Hexagon AB, 2022, All rights reserved.

Report – Instrument air outlet_LI4732 C220006CLC008

PV-Elite Calculation Summary

Client: Airpack Nederland BV.
Client location: Zierikzee
Ref number client: 17811-OO-0702(KP)

PPV Engineering

Author: H.Hoezen
- Telephone: +31 (0)594 581010
- E-mail: h.hoezen@ppv-engineering.nl

June 22, 2022
Order number: P22-115-01
Document number: 22-11501-C06
Revision: 1

Table of Contents

Cover Sheet	2
Vessel Design Summary:	3
Nozzle Summary:	5
Nozzle Schedule:	6
Bill of Material:	7
Input Echo:	8
Internal Pressure Calculations:	13
Element and Detail Weights:	18
Nozzle Flange MAWP:	20
Nozzle Calcs.: N2	21
Nozzle Calcs.: N3	24
Nozzle Calcs.: Noz N1	27

Pulsation damper outlet
C220006CLC008
Static Calculation

DESIGN CALCULATION

In Accordance with ASME Section VIII Division 1

ASME Code Version : 2021

Analysis Performed by : PPV-Engineering B.V.

Job File : ...\Instrument air outlet_LI4732.pvdb

Date of Analysis : Jun 21,2022 9:30am

PV Elite 24 SP1, March 2022

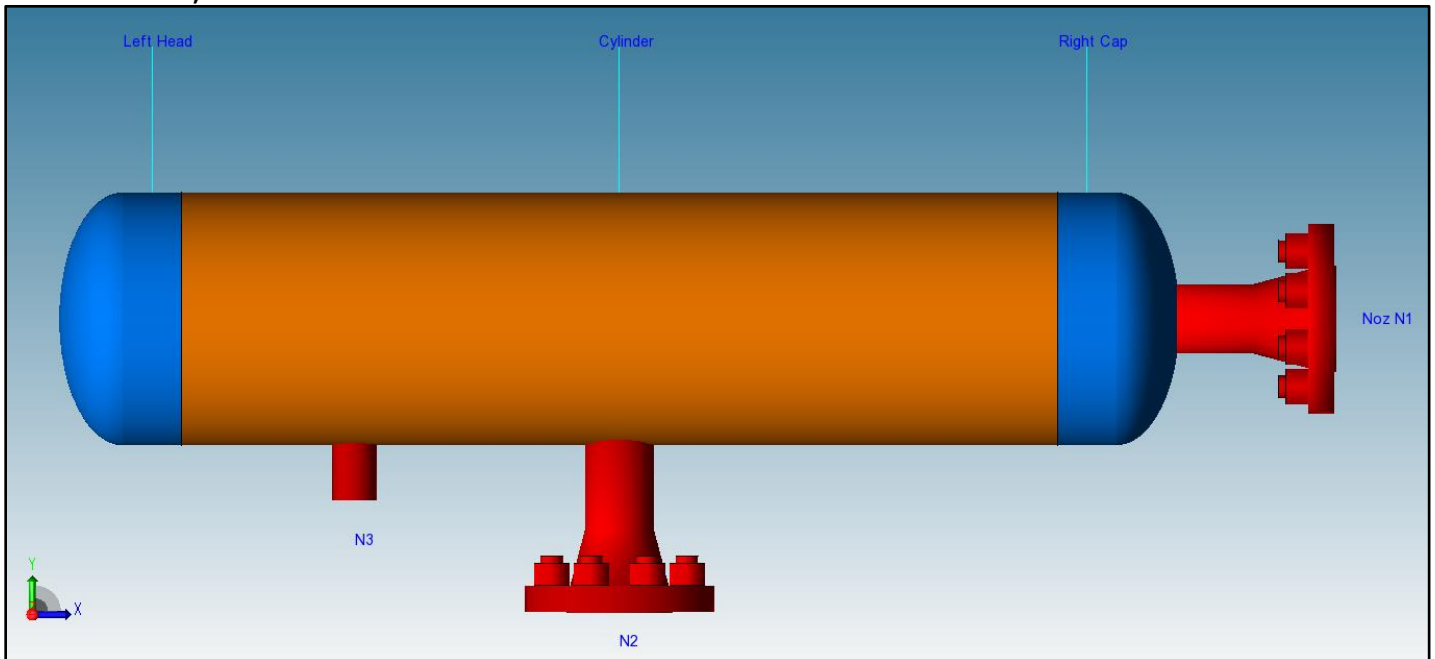

Pulsation damper outlet

C220006CLC008

Static Calculation

PV Elite 24 SP1 Licensee: PPV-Engineering B.V.

FileName : Instrument air outlet_LI4732

Vessel Design Summary: Step: 15 9:30am Jun 21, 2022

Vessel Design Summary:

ASME Code, Section VIII Division 1, 2021

Diameter Spec : 219.100 mm OD
Vessel Design Length, Tangent to Tangent 862.63 mm
Specified Datum Line Distance 51.31 mm
Internal Design Temperature 210 °C
Internal Design Pressure 2.400 MPa
External Design Temperature 210 °C
Maximum Allowable Working Pressure 3.864 MPa
Shop Test Pressure 6.640 MPa
Required Minimum Design Metal Temperature -28.9 °C
Warmest Computed Minimum Design Metal Temperature -47.0 °C
Wind Design Code No Wind Loads
Earthquake Design Code No Seismic

Materials of Construction:

Component Type	Material	Class	Thickness	UNS #	Normal ized	Impact Tested
Shell	SA-106 B	K03006	No	No
Head	SA-234 WPB	K03006	No	No
Nozzle	SA-106 B	K03006	No	No
Nozzle Flg	SA-105	K03504	No	No

Normalized is determined based on the UCS-66 material curve selection and Figure UCS-66.
Impact Tested is based on material selection and material data properties.

Element Pressures and MAWP (MPa & mm):

Element Description or Type	Design Pressure + Stat. head	Ext. Press.	Element M.A.W.P	Total Corrosion Allowance	Str. Flg. Gov.	In Creep Range
Left Head	2.400	0.00	4.830	3.0000	Yes	No
Cylinder	2.400	0.00	3.864	3.0000	N/A	No
Right Cap	2.400	0.00	4.830	3.0000	Yes	No

Element Types and Properties:

Element Type	"To" Elev mm	Element Length mm	Nominal Thickness mm	Finished Thickness mm	Reqd Thk Internal mm	Reqd Thk External mm	Long Eff	Circ Eff
Ellipse	0.0	51.3	8.2	8.2	5.5	...	0.85	0.85
Cylinder	760.0	760.0	8.2	7.2	5.6	...	0.85	0.85
Ellipse	811.3	51.3	8.2	8.2	5.5	...	0.85	0.85

Pulsation damper outlet

C220006CLC008

Static Calculation

PV Elite 24 SP1 Licensee: PPV-Engineering B.V.

FileName : Instrument air outlet_LI4732 -----

Vessel Design Summary: Step: 15 9:30am Jun 21,2022

Weights:

Fabricated - Bare W/O Removable Internals	54.1	kgm
Shop Test - Fabricated + Water (Full)	84.6	kgm
Shipping - Fab. + Rem. Intls.+ Shipping App.	54.1	kgm
Erected - Fab. + Rem. Intls.+ Insul. (etc)	54.1	kgm
Empty - Fab. + Intls. + Details + Wghts.	54.1	kgm
Operating - Empty + Operating Liquid (No CA)	54.1	kgm
Field Test - Empty Weight + Water (Full)	84.6	kgm

PV Elite is a trademark of Hexagon AB, 2022, All rights reserved.

Pulsation damper outlet

C220006CLC008

Static Calculation

PV Elite 24 SP1 Licensee: PPV-Engineering B.V.

FileName : Instrument air outlet_LI4732

Nozzle Summary: Step: 13 9:30am Jun 21,2022

Nozzle Calculation Summary (MPa & mm):

Description	MAWP	Ext	MAPNC	UG-45	[tr]	Weld Path	Areas or Stresses
N2	3.864	OK	5.15	OK	No Calc[*]
N3	3.864	OK	5.15	OK	No Calc[*]
Noz N1	4.83	OK	5.05	OK	No Calc[*]

Nozzle MAWP Summary:

Minimum MAWP Nozzles : 3.864 Nozzle : N3
 Minimum MAWP Shells/Flanges : 3.864 Element : Cylinder
 Minimum MAPnc Shells/Flanges : 6.726 Element : Cylinder

Computed Vessel M.A.W.P. : 3.864 MPa

[*] - This was a small opening and the areas were not computed.

Note: MAWPs (Internal Case) shown above are at the High Point.

Multiple output lines for the same nozzle indicates required Code calculations in both the longitudinal and circumferential planes of reinforcement where applicable.

Check the Spatial Relationship between the Nozzles:

From Node	Nozzle Description	X Coordinate mm	Layout Angle deg	Dia. Limit mm
20	N2	431.315	270.000	97.700
20	N3	201.315	270.000	54.672
30	Noz N1	0.000	0.000	97.700

The nozzle spacing is computed by the following:

= sqrt(ll² + lc²) where

ll - Arc length along the inside vessel surface in the long. direction.

lc - Arc length along the inside vessel surface in the circ. direction

If any interferences/violations are found, they will be noted below.

No interference violations have been detected!

PV Elite is a trademark of Hexagon AB, 2022, All rights reserved.

Pulsation damper outlet

C220006CLC008

Static Calculation

PV Elite 24 SP1 Licensee: PPV-Engineering B.V.

FileName : Instrument air outlet_LI4732

Nozzle Schedule: Step: 12 9:30am Jun 21, 2022

Nozzle Schedule:

Description	Nominal or Actual Size	Schd or FVC Type	Flg Type	Nozzle O/Dia mm	Wall Thk mm	Reinforcing Pad Diameter	Thk mm	Cut Length mm	Flg Class
N3	38 mm Actual		None	38.1	8.382	56	...
N2	50 mm	160	WNF	60.3	8.738	85	300
Noz N1	50 mm	160	WNF	60.3	8.738	73	300

General Notes for the above table:

The Cut Length is the Outside Projection + Inside Projection + Drop + In Plane Shell Thickness. This value does not include weld gaps, nor does it account for shrinkage.

In the case of Oblique Nozzles, the Outside Diameter must be increased. The Re-Pad WIDTH around the nozzle is calculated as follows:
Width of Pad = (Pad Outside Dia. (per above) - Nozzle Outside Dia.)/2

For hub nozzles, the thickness and diameter shown are those of the smaller and thinner section.

Nozzle Material and Weld Fillet Leg Size Details (mm):

Description	Material	Shl Grve Weld	Noz Shl/Pad Weld	Pad OD Weld	Pad Grve Weld	Inside Weld
N3	SA-106 B	8.340	6.000
N2	SA-106 B	8.340	6.000
Noz N1	SA-106 B	7.160	6.000

Note: The Outside projections below do not include the flange thickness.

Nozzle Miscellaneous Data:

Description	Elev/Distance From Datum mm	Layout Angle deg	Proj Outside mm	Proj Inside mm	Installed in Component
N3	150.000	270.0	47.62	0.00	Cylinder
N2	380.000	270.0	74.00	0.00	Cylinder
Noz N1	...	0.0	63.00	0.00	Right Cap

PV Elite is a trademark of Hexagon AB, 2022, All rights reserved.

Pulsation damper outlet

C220006CLC008

Static Calculation

PV Elite 24 SP1 Licensee: PPV-Engineering B.V.

FileName : Instrument air outlet_LI4732 -----

Bill of Material: Step: 11 9:30am Jun 21,2022

Bill of Materials:

QTY	DESCRIPTION	MATERIAL
2	ELLIPTICAL HEAD: 2.0 X 1, 8.2mm THK X 202.7mm ID X 51.3mm	SA-234 WPB
1	CYLINDER: 8.2mm THK X 204.8mm ID X 760.0mm	SA-106 B
1	NAMEPLATE	...

PV Elite is a trademark of Hexagon AB, 2022, All rights reserved.

Pulsation damper outlet

C220006CLC008

Static Calculation

PV Elite 24 SP1 Licensee: PPV-Engineering B.V.

FileName : Instrument air outlet_LI4732 -----

Input Echo: Step: 1 9:30am Jun 21, 2022

Units used in this Analysis (SI_ASME):

Name	System Unit	Constant	User Unit
Length	Feet	304.8000	mm
Force	Pounds	4.4480	N
Mass	Pounds	0.4536	kgm
Area	sq. inches	645.1600	mm ²
Moment	ft. lbs.	1356.3000	N-mm
Stress	lbs./sq.in.	0.0069	MPa
Temperature	Degrees F	0.5556	°C
Pressure	psig	0.0069	MPa
Elast. Modulus	lbs./sq.in.	0.0069	MPa
Pipe Density	lbs./cu.in.	0.0277	kg/cm ³
Ins. Density	lbs./cu.ft.	0.1602E-04	kg/cm ³
Fluid Density	lbs./cu.ft.	0.1602E-04	kg/cm ³
Wind Speed	miles/hr	1.6093	km/hr
Tray Weight	lbs./sq.ft.	0.0005	kg/cm ²
Inertia	in.**4	416231.0000	mm**4
G Load	G's	1.0000	g's
Wind Load	lbs./sq.ft.	0.0479	kPa
Elevation	Feet	304.8000	mm
Volume	in.**3	0.0164	ltr
Diameter	inches	25.4000	mm
Thickness	inches	25.4000	mm

PV Elite Vessel Analysis Program: Input Data

Pulsation damper outlet

C220006CLC008

Static Calculation

Design Internal Pressure (for Hydrotest)	2.4	MPa
Design Internal Temperature	210.0	°C
Projection of Nozzle from Vessel Top	0	mm
Projection of Nozzle from Vessel Bottom	0	mm
Minimum Design Metal Temperature	-28.9	°C
Type of Construction	Welded	
Special Service	None	
Degree of Radiography	RT-3	
Use Higher Longitudinal Stresses (Flag)	Y	
Select t for Internal Pressure (Flag)	N	
Select t for External Pressure (Flag)	N	
Select t for Axial Stress (Flag)	N	
Select Location for Stiff. Rings (Flag)	N	
Consider Vortex Shedding	N	

Shop Pressure Test:

Type of Pressure Test	User Entered Pressure
Pressure Test Position	Horizontal

Load Case 1	NP+EW+WI+FW+BW
Load Case 2	NP+EW+EE+FS+BS
Load Case 3	NP+OW+WI+FW+BW
Load Case 4	NP+OW+EQ+FS+BS
Load Case 5	NP+HW+HI
Load Case 6	NP+HW+HE

Pulsation damper outlet

C220006CLC008

Static Calculation

PV Elite 24 SP1 Licensee: PPV-Engineering B.V.

FileName : Instrument air outlet_LI4732 -----

Input Echo: Step: 1 9:30am Jun 21, 2022

Load Case 7	IP+OW+WI+FW+BW
Load Case 8	IP+OW+EQ+FS+BS
Load Case 9	EP+OW+WI+FW+BW
Load Case 10	EP+OW+EQ+FS+BS
Load Case 11	HP+HW+HI
Load Case 12	HP+HW+HE
Load Case 13	IP+WE+EW
Load Case 14	IP+WF+CW
Load Case 15	IP+VO+OW
Load Case 16	IP+VE+EW
Load Case 17	NP+VO+OW
Load Case 18	FS+BS+IP+OW
Load Case 19	FS+BS+EP+OW

Wind Design Code No Wind Loads

Seismic Design Code No Seismic

Design Pressure + Static Head	Y
Consider MAP New and Cold in Noz. Design	N
Consider External Loads for Nozzle Des.	Y
Use ASME VIII-1 Appendix 1-9	N

Perform Blast Load Analysis	No
Material Database Year	Current w/Addenda or Code Year

Configuration Directives:

Do not use Nozzle MDMT Interpretation VIII-1 01-37	No
Use Table G instead of exact equation for "A"	Yes
Shell Head Joints are Tapered	Yes
Compute "K" in corroded condition	Yes
Use Code Case 2286	No
Use the MAWP to compute the MDMT	Yes
For thickness ratios ≤ 0.35 , MDMT will be -155F (-104C)	Yes
For PWHT & P1 Materials the MDMT can be $< -55F (-48C)$	No
Using Metric Material Databases, ASME II D	No
Calculate B31.3 type stress for Nozzles with Loads	Yes
Reduce the MDMT due to lower membrane stress	Yes
Consider Longitudinal Stress in MDMT Calculations	Yes

Complete Listing of Vessel Elements and Details:

Element From Node	10
Element To Node	20
Element Type	Elliptical
Description	Left Head
Distance "FROM" to "TO"	51.315 mm
Element Outside Diameter	219.1 mm
Element Thickness	8.18 mm
Internal Corrosion Allowance	3 mm
Nominal Thickness	8.18 mm
External Corrosion Allowance	0 mm
Design Internal Pressure	2.4 MPa
Design Temperature Internal Pressure	210 °C
Design External Pressure	0 MPa
Design Temperature External Pressure	210 °C
Effective Diameter Multiplier	1.2

Pulsation damper outlet
C220006CLC008

Static Calculation

PV Elite 24 SP1 Licensee: PPV-Engineering B.V.

FileName : Instrument air outlet_LI4732 -----

Input Echo: Step: 1 9:30am Jun 21,2022

Material Name	SA-234 WPB	
Allowable Stress, Ambient	117.9	MPa
Allowable Stress, Operating	117.9	MPa
Allowable Stress, Hydrotest	153.28	MPa
Material Density	0.00775	kg/cm ³
P Number Thickness	30.988	mm
Yield Stress, Operating	205.2	MPa
UCS-66 Chart Curve Designation	B	
External Pressure Chart Name	CS-2	
UNS Number	K03006	
Product Form	Smls. & wld. fittings	
Efficiency, Longitudinal Seam	0.85	
Efficiency, Circumferential Seam	0.85	
Elliptical Head Factor	2.0	
Weld is pre-Heated	No	

Element From Node	20	
Element To Node	30	
Element Type	Cylinder	
Description	Cylinder	
Distance "FROM" to "TO"	760	mm
Element Outside Diameter	219.1	mm
Element Thickness	7.16	mm
Internal Corrosion Allowance	3	mm
Nominal Thickness	8.18	mm
External Corrosion Allowance	0	mm
Design Internal Pressure	2.4	MPa
Design Temperature Internal Pressure	210	°C
Design External Pressure	0	MPa
Design Temperature External Pressure	210	°C
Effective Diameter Multiplier	1.2	
Material Name	SA-106 B	
Allowable Stress, Ambient	117.9	MPa
Allowable Stress, Operating	117.9	MPa
Allowable Stress, Hydrotest	153.28	MPa
Material Density	0.00775	kg/cm ³
P Number Thickness	30.988	mm
Yield Stress, Operating	205.2	MPa
UCS-66 Chart Curve Designation	B	
External Pressure Chart Name	CS-2	
UNS Number	K03006	
Product Form	Smls. pipe	
Efficiency, Longitudinal Seam	0.85	
Efficiency, Circumferential Seam	0.85	
Weld is pre-Heated	No	

Element From Node	20	
Detail Type	Nozzle	
Detail ID	N2	
Dist. from "FROM" Node / Offset dist	380	mm
Nozzle Diameter	50	mm
Nozzle Schedule	160	
Nozzle Class	300	
Layout Angle	270.0	
Blind Flange (Y/N)	N	
Weight of Nozzle (Used if > 0)	0	N
Grade of Attached Flange	GR 1.1	

Pulsation damper outlet

C220006CLC008

Static Calculation

PV Elite 24 SP1 Licensee: PPV-Engineering B.V.

FileName : Instrument air outlet_LI4732 -----

Input Echo: Step: 1 9:30am Jun 21,2022

Nozzle Matl	SA-106 B
Element From Node	20
Detail Type	Nozzle
Detail ID	N3
Dist. from "FROM" Node / Offset dist	150 mm
Nozzle Diameter	38.1 mm
Nozzle Schedule	None
Nozzle Class	None
Layout Angle	270.0
Blind Flange (Y/N)	N
Weight of Nozzle (Used if > 0)	0 N
Grade of Attached Flange	None
Nozzle Matl	SA-106 B

Element From Node	30
Element To Node	40
Element Type	Elliptical
Description	Right Cap
Distance "FROM" to "TO"	51.315 mm
Element Outside Diameter	219.1 mm
Element Thickness	8.18 mm
Internal Corrosion Allowance	3 mm
Nominal Thickness	8.18 mm
External Corrosion Allowance	0 mm
Design Internal Pressure	2.4 MPa
Design Temperature Internal Pressure	210 °C
Design External Pressure	0 MPa
Design Temperature External Pressure	210 °C
Effective Diameter Multiplier	1.2
Material Name	SA-234 WPB
Allowable Stress, Ambient	117.9 MPa
Allowable Stress, Operating	117.9 MPa
Allowable Stress, Hydrotest	153.28 MPa
Material Density	0.00775 kg/cm ³
P Number Thickness	30.988 mm
Yield Stress, Operating	205.2 MPa
UCS-66 Chart Curve Designation	B
External Pressure Chart Name	CS-2
UNS Number	K03006
Product Form	Smls. & wld. fittings
Efficiency, Longitudinal Seam	0.85
Efficiency, Circumferential Seam	0.85
Elliptical Head Factor	2.0
Weld is pre-Heated	No

Element From Node	30
Detail Type	Nozzle
Detail ID	Noz N1
Dist. from "FROM" Node / Offset dist	0 mm
Nozzle Diameter	50 mm
Nozzle Schedule	160
Nozzle Class	300
Layout Angle	0.0
Blind Flange (Y/N)	N
Weight of Nozzle (Used if > 0)	0 N
Grade of Attached Flange	GR 1.1

Pulsation damper outlet

C220006CLC008

Static Calculation

PV Elite 24 SP1 Licensee: PPV-Engineering B.V.

FileName : Instrument air outlet_LI4732 -----

Input Echo: Step: 1 9:30am Jun 21,2022

Nozzle Matl

SA-106 B

PV Elite is a trademark of Hexagon AB, 2022, All rights reserved.

Pulsation damper outlet
C220006CLC008

Static Calculation

PV Elite 24 SP1 Licensee: PPV-Engineering B.V.

FileName : Instrument air outlet_LI4732

Internal Pressure Calculations: Step: 3 9:30am Jun 21, 2022

Internal Pressure Results Summary:

Element Thickness, Pressure, Diameter and Allowable Stress :

From	To	Int. Press + Liq. Hd MPa	Nominal Thickness mm	Total Corr Allowance mm	Element Diameter mm	Allowable Stress(SE) MPa
Left Head		2.4	8.18	3	219.1	100.22
Cylinder		2.4	8.18	3	219.1	100.22
Right Cap		2.4	8.18	3	219.1	100.22

Element Required Thickness and MAWP :

From	To	Design Pressure MPa	M.A.W.P. Corroded MPa	M.A.P. New & Cold MPa	Minimum Thickness mm	Required Thickness mm
Left Head		2.4	4.83	8.022	8.18	5.4759
Cylinder		2.4	3.864	6.726	7.16	5.59857
Right Cap		2.4	4.83	8.022	8.18	5.4759
Minimum			3.864	5.11		

Note : The M.A.P.(NC) is Governed by a Flange !

MAWP: 3.864 MPa, limited by: Cylinder.

Elements Suitable for Design Internal Pressure.

Internal Pressure Calculation Results:

ASME Code, Section VIII Division 1, 2021

Elliptical Head From 10 To 20 SA-234 WPB , UCS-66 Crv. B at 210 °C

Left Head

Longitudinal Joint: User Defined

Material UNS Number: K03006

Required Thickness due to Internal Pressure [tr]:

$$\begin{aligned}
 &= (P \cdot D_o \cdot K_{cor}) / (2 \cdot S \cdot E + 2 \cdot P \cdot (K_{cor} - 0.1)) \text{ per Appendix 1-4 (c)} \\
 &= (2.4 \cdot 219.1 \cdot 0.963) / (2 \cdot 117.9 \cdot 0.85 + 2 \cdot 2.4 \cdot (0.963 - 0.1)) \\
 &= 2.4759 + 3.0000 = 5.4759 \text{ mm}
 \end{aligned}$$

Max. Allowable Working Pressure at given Thickness, corroded [MAWP]:

$$\begin{aligned}
 &= (2 \cdot S \cdot E \cdot t) / (K_{cor} \cdot D_o - 2 \cdot t \cdot (K_{cor} - 0.1)) \text{ per Appendix 1-4 (c)} \\
 &= (2 \cdot 117.9 \cdot 0.85 \cdot 5.18) / (0.963 \cdot 219.1 - 2 \cdot 5.18 \cdot (0.963 - 0.1)) \\
 &= 5.137 \text{ MPa}
 \end{aligned}$$

Maximum Allowable Pressure, New and Cold [MAPNC]:

$$\begin{aligned}
 &= (2 \cdot S \cdot E \cdot t) / (K \cdot D_o - 2 \cdot t \cdot (K - 0.1)) \text{ per Appendix 1-4 (c)} \\
 &= (2 \cdot 117.9 \cdot 0.85 \cdot 8.18) / (1 \cdot 219.1 - 2 \cdot 8.18 \cdot (1 - 0.1)) \\
 &= 8.022 \text{ MPa}
 \end{aligned}$$

Pulsation damper outlet
C220006CLC008

Static Calculation

PV Elite 24 SP1 Licensee: PPV-Engineering B.V.

FileName : Instrument air outlet_LI4732 -----

Internal Pressure Calculations: Step: 3 9:30am Jun 21, 2022

Actual stress at given pressure and thickness, corroded [Sact]:

$$= (P \cdot (K_{cor} \cdot D_o - 2 \cdot t \cdot (K_{cor} - 0.1))) / (2 \cdot E \cdot t)$$

$$= (2.4 \cdot (0.963 \cdot 219.1 - 2 \cdot 5.18 \cdot (0.963 - 0.1))) / (2 \cdot 0.85 \cdot 5.18)$$

$$= 55.083 \text{ MPa}$$

Straight Flange Required Thickness:

$$= (P \cdot R_o) / (S \cdot E + 0.4 \cdot P) + c_a \text{ per Appendix 1-1 (a)(1)}$$

$$= (2.4 \cdot 109.5) / (117.9 \cdot 0.85 + 0.4 \cdot 2.4) + 3$$

$$= 5.599 \text{ mm}$$

Straight Flange Maximum Allowable Working Pressure:

$$= (S \cdot E \cdot t) / (R_o - 0.4 \cdot t) \text{ per Appendix 1-1 (a)(1)}$$

$$= (117.9 \cdot 0.85 \cdot 5.18) / (109.5 - 0.4 \cdot 5.18)$$

$$= 4.83 \text{ MPa}$$

Factor K, corroded condition [Kcor]:

$$= (2 + (\text{Inside Diameter} / (2 \cdot \text{Inside Head Depth}))^2) / 6$$

$$= (2 + (208.7 / (2 \cdot 53.68))^2) / 6$$

$$= 0.963266$$

MDMT Calculations in the Knuckle Portion:

Govrn. thk, tg = 8.18, tr = 3.938, c = 3 mm, E* = 0.85

Thickness Ratio = tr * E* / (tg - c) = 0.646, Temp. Reduction = 20 °C

Min Metal Temp. w/o impact per UCS-66, Curve B -29 °C
Min Metal Temp. at Required thickness (UCS 66.1) -48 °C

MDMT Calculations in the Head Straight Flange:

Govrn. thk, tg = 8.18, tr = 4.16, c = 3 mm, E* = 0.85

Thickness Ratio = tr * E* / (tg - c) = 0.683, Temp. Reduction = 18 °C

Min Metal Temp. w/o impact per UCS-66, Curve B -29 °C
Min Metal Temp. at Required thickness (UCS 66.1) -47 °C

Cylindrical Shell From 20 To 30 SA-106 B , UCS-66 Crv. B at 210 °C

Cylinder

Longitudinal Joint: Spot Radiography per UW-11(b) Type 1

Material UNS Number: K03006

Required Thickness due to Internal Pressure [tr]:

$$= (P \cdot R_o) / (S \cdot E + 0.4 \cdot P) \text{ per Appendix 1-1 (a)(1)}$$

$$= (2.4 \cdot 109.5) / (117.9 \cdot 0.85 + 0.4 \cdot 2.4)$$

$$= 2.5986 + 3.0000 = 5.5986 \text{ mm}$$

Max. Allowable Working Pressure at given Thickness, corroded [MAWP]:

$$= (S \cdot E \cdot t) / (R_o - 0.4 \cdot t) \text{ per Appendix 1-1 (a)(1)}$$

$$= (117.9 \cdot 0.85 \cdot 4.16) / (109.5 - 0.4 \cdot 4.16)$$

$$= 3.864 \text{ MPa}$$

Maximum Allowable Pressure, New and Cold [MAPNC]:

$$= (S \cdot E \cdot t) / (R_o - 0.4 \cdot t) \text{ per Appendix 1-1 (a)(1)}$$

$$= (117.9 \cdot 0.85 \cdot 7.16) / (109.5 - 0.4 \cdot 7.16)$$

$$= 6.726 \text{ MPa}$$

Pulsation damper outlet
C220006CLC008

Static Calculation

PV Elite 24 SP1 Licensee: PPV-Engineering B.V.

FileName : Instrument air outlet_LI4732 -----

Internal Pressure Calculations: Step: 3 9:30am Jun 21, 2022

Actual stress at given pressure and thickness, corroded [Sact]:

$$\begin{aligned} &= (P*(Ro-0.4*t))/(E*t) \\ &= (2.4*((109.5-0.4*4.16)))/(0.85*4.16) \\ &= 73.226 \text{ MPa} \end{aligned}$$

Minimum Design Metal Temperature Results:

Govrn. thk, tg = 7.16, tr = 2.016, c = 3 mm, E* = 0.85

Thickness Ratio = tr * E*/(tg - c) = 0.412, Temp. Reduction = 48 °C

Min Metal Temp. w/o impact per UCS-66, Curve B -29 °C

Min Metal Temp. at Required thickness (UCS 66.1) -48 °C

Elliptical Head From 30 To 40 SA-234 WPB, UCS-66 Crv. B at 210 °C

Right Cap

Longitudinal Joint: User Defined

Material UNS Number: K03006

Required Thickness due to Internal Pressure [tr]:

$$\begin{aligned} &= (P*Do*Kcor)/(2*S*E+2*P*(Kcor-0.1)) \text{ per Appendix 1-4 (c)} \\ &= (2.4*219.1*0.963)/(2*117.9*0.85+2*2.4*(0.963-0.1)) \\ &= 2.4759 + 3.0000 = 5.4759 \text{ mm} \end{aligned}$$

Max. Allowable Working Pressure at given Thickness, corroded [MAWP]:

$$\begin{aligned} &= (2*S*E*t)/(Kcor*Do-2*t*(Kcor-0.1)) \text{ per Appendix 1-4 (c)} \\ &= (2*117.9*0.85*5.18)/(0.963*219.1-2*5.18*(0.963-0.1)) \\ &= 5.137 \text{ MPa} \end{aligned}$$

Maximum Allowable Pressure, New and Cold [MAPNC]:

$$\begin{aligned} &= (2*S*E*t)/(K*Do-2*t*(K-0.1)) \text{ per Appendix 1-4 (c)} \\ &= (2*117.9*0.85*8.18)/(1*219.1-2*8.18*(1-0.1)) \\ &= 8.022 \text{ MPa} \end{aligned}$$

Actual stress at given pressure and thickness, corroded [Sact]:

$$\begin{aligned} &= (P*(Kcor*Do-2*t*(Kcor-0.1)))/(2*E*t) \\ &= (2.4*(0.963*219.1-2*5.18*(0.963-0.1)))/(2*0.85*5.18) \\ &= 55.083 \text{ MPa} \end{aligned}$$

Straight Flange Required Thickness:

$$\begin{aligned} &= (P*Ro)/(S*E+0.4*P) + ca \text{ per Appendix 1-1 (a)(1)} \\ &= (2.4*109.5)/(117.9*0.85+0.4*2.4)+3 \\ &= 5.599 \text{ mm} \end{aligned}$$

Straight Flange Maximum Allowable Working Pressure:

$$\begin{aligned} &= (S*E*t)/(Ro-0.4*t) \text{ per Appendix 1-1 (a)(1)} \\ &= (117.9 * 0.85 * 5.18)/(109.5 - 0.4 * 5.18) \\ &= 4.83 \text{ MPa} \end{aligned}$$

Factor K, corroded condition [Kcor]:

$$\begin{aligned} &= (2 + (\text{Inside Diameter}/(2 * \text{Inside Head Depth}))^2)/6 \\ &= (2 + (208.7/(2 * 53.68))^2)/6 \\ &= 0.963266 \end{aligned}$$

MDMT Calculations in the Knuckle Portion:

Govrn. thk, tg = 8.18, tr = 3.938, c = 3 mm, E* = 0.85

Pulsation damper outlet
C220006CLC008

Static Calculation

PV Elite 24 SP1 Licensee: PPV-Engineering B.V.

FileName : Instrument air outlet_LI4732 -----

Internal Pressure Calculations: Step: 3 9:30am Jun 21, 2022

Thickness Ratio = $tr * E^*/(tg - c) = 0.646$, Temp. Reduction = 20 °C

Min Metal Temp. w/o impact per UCS-66, Curve B -29 °C
Min Metal Temp. at Required thickness (UCS 66.1) -48 °C

MDMT Calculations in the Head Straight Flange:

Govrn. thk, tg = 8.18, tr = 4.16, c = 3 mm, $E^* = 0.85$
Thickness Ratio = $tr * E^*/(tg - c) = 0.683$, Temp. Reduction = 18 °C

Min Metal Temp. w/o impact per UCS-66, Curve B -29 °C
Min Metal Temp. at Required thickness (UCS 66.1) -47 °C

Note: Heads and Shells Exempted to -20F (-29C) by paragraph UG-20F

Hydrostatic Test Pressure Results:

Pressure per UG99b	= 1.30 * M.A.W.P. * Sa/S	5.024 MPa
Pressure per UG99b[35]	= 1.30 * Design Pres * Sa/S	3.120 MPa
Pressure per UG99c	= 1.30 * M.A.P. - Head(Hyd)	6.643 MPa
Pressure per UG100	= 1.10 * M.A.W.P. * Sa/S	4.251 MPa
Pressure per PED	= max(1.43*DP, 1.25*DP*ratio)	3.432 MPa
Pressure per App 27-4	= M.A.W.P.	3.864 MPa
User Defined Hydrostatic Test Pressure at High Point		6.640 MPa

Horizontal Test performed per: User Hydro Pressure

Please note that Nozzle, Shell, Head, Flange, etc MAWPs are all considered when determining the hydrotest pressure for those test types that are based on the MAWP of the vessel.

Stresses on Elements due to Test Pressure (MPa):

From To	Stress	Allowable	Ratio	Pressure
Left Head	97.6	153.3	0.637	6.64
Cylinder	116.4	153.3	0.760	6.64
Right Cap	97.6	153.3	0.637	6.64

Stress ratios for Nozzle and Pad Materials (MPa):

Description	Pad/Nozzle	Ambient	Operating	Ratio
N2	Nozzle	117.90	117.90	1.000
N3	Nozzle	117.90	117.90	1.000
Noz N1	Nozzle	117.90	117.90	1.000
Minimum				1.000

Stress ratios for Pressurized Vessel Elements (MPa):

Description	Ambient	Operating	Ratio
Left Head	117.90	117.90	1.000
Cylinder	117.90	117.90	1.000
Right Cap	117.90	117.90	1.000

Pulsation damper outlet

C220006CLC008

Static Calculation

PV Elite 24 SP1 Licensee: PPV-Engineering B.V.

FileName : Instrument air outlet_LI4732 -----

Internal Pressure Calculations: Step: 3 9:30am Jun 21,2022

 Minimum 1.000

Hoop Stress in Nozzle Wall during Pressure Test (MPa):

Description	Ambient	Operating	Ratio
N2	20.27	153.28	0.132
N3	12.44	153.28	0.081
Noz N1	20.27	153.28	0.132

Elements Suitable for Test Pressure.

PV Elite is a trademark of Hexagon AB, 2022, All rights reserved.

Pulsation damper outlet
C220006CLC008

Static Calculation

PV Elite 24 SP1 Licensee: PPV-Engineering B.V.

FileName : Instrument air outlet_LI4732

Element and Detail Weights: Step: 5 9:30am Jun 21,2022

Element and Detail Weights:

From	To	Element Metal Wgt. kgm	Element ID Volume ltr	Corroded Metal Wgt. kgm	Corroded ID Volume ltr	Extra due Misc % kgm
10	20	5.5314	2.7479	3.50277	2.94718	...
20	30	32.2363	25.0355	20.7012	26.5241	...
30	40	5.5314	2.7479	3.50277	2.94718	...
Total		43	30.53	27	32.42	0

Weight of Details:

From	Type	Weight of Detail kgm	X Offset, Dtl. Cent. mm	Y Offset, Dtl. Cent. mm	Z Offset Dtl. Cent. mm	Description
20	Noz1	5.31107	380	-132.552	...	N2
20	Noz1	0.28886	150	-121.44	...	N3
30	Noz1	5.19036	102	Noz N1

Total Weight of Each Detail Type:

Nozzles	10.8

Sum of the Detail Weights	10.8 kgm

Weight Summation Results: (kgm)

	Fabricated	Shop Test	Shipping	Erected	Empty	Operating
Main Elements	43.3	43.3	43.3	43.3	43.3	43.3
Nozzles	10.8	10.8	10.8	10.8	10.8	10.8
Test Liquid	...	30.5
Totals	54.1	84.6	54.1	54.1	54.1	54.1

Weight Summary:

Fabricated Wt.	- Bare Weight without Removable Internals	54.1 kgm
Shop Test Wt.	- Fabricated Weight + Water (Full)	84.6 kgm
Shipping Wt.	- Fab. Weight + removable Intls.+ Shipping App.	54.1 kgm
Erected Wt.	- Fab. Wt + or - loose items (trays,platforms etc.)	54.1 kgm
Ope. Wt. no Liq	- Fab. Weight + Internals. + Details + Weights	54.1 kgm
Operating Wt.	- Empty Weight + Operating Liq. Uncorroded	54.1 kgm
Oper. Wt. + CA	- Corr Wt. + Operating Liquid	38.5 kgm
Field Test Wt.	- Empty Weight + Water (Full)	84.6 kgm

Note:

The Corroded Weight and thickness are used in the Horizontal Vessel Analysis (Ope Case) and Earthquake Load Calculations.

Outside Surface Areas of Elements:

From	To	Surface Area
------	----	-----------------

Pulsation damper outlet

C220006CLC008

Static Calculation

PV Elite 24 SP1 Licensee: PPV-Engineering B.V.

FileName : Instrument air outlet_LI4732 -----

Element and Detail Weights: Step: 5 9:30am Jun 21,2022

		mm ²
10	20	87357.8
20	30	527996
30	40	87357.8
Total		702711.750 mm ²

PV Elite is a trademark of Hexagon AB, 2022, All rights reserved.

Pulsation damper outlet

C220006CLC008

Static Calculation

PV Elite 24 SP1 Licensee: PPV-Engineering B.V.

FileName : Instrument air outlet_LI4732 -----

Nozzle Flange MAWP: Step: 6 9:30am Jun 21,2022

Nozzle Flange MAWP Results: (MPa & °C)

Nozzle Description	Flange Rating		Design	Class	Grade/Group	Equiv. Press	Max Pressure		
	Op.	Ambient	Temp				UG-44(b)	50%	DNV
N2	4.34	5.11	210	300	GR 1.1
Noz N1	4.34	5.11	210	300	GR 1.1
Min Rating	4.342	5.110 MPa [for Core Elements]				

Pressure Ratings are per ASME B16.5 2017 Metric Edition

PV Elite is a trademark of Hexagon AB, 2022, All rights reserved.

Pulsation damper outlet
 C220006CLC008

Static Calculation

PV Elite 24 SP1 Licensee: PPV-Engineering B.V.

FileName : Instrument air outlet_LI4732 -----

Nozzle Calcs.: N2 Nozl: 13 9:30am Jun 21,2022

Input, Nozzle Desc: N2 From: 20

Pressure for Reinforcement Calculations	P	2.4000	MPa
Temperature for Internal Pressure	Temp	210	°C
Parent Material		SA-106 B	
Parent Allowable Stress at Temperature	Sv	117.90	MPa
Parent Allowable Stress At Ambient	Sva	117.90	MPa
Inside Diameter of Cylindrical Shell	D	202.74	mm
Shell Finished (Minimum) Thickness	t	7.1600	mm
Shell Internal Corrosion Allowance	c	3.0000	mm
Shell External Corrosion Allowance	co	0.0000	mm
Distance from Bottom/Left Tangent		431.31	mm
User Entered Minimum Design Metal Temperature		-28.89	°C

Type of Element Connected to the Parent : Nozzle

Material		SA-106 B	
Material UNS Number		K03006	
Material Specification/Type		Smls. pipe	
Allowable Stress at Temperature	Sn	117.90	MPa
Allowable Stress At Ambient	Sna	117.90	MPa
Diameter Basis (for tr calc only)		Outside	
Layout Angle		270.00	deg
Diameter		50.0000	mm
Size and Thickness Basis		Nominal	
Nominal Thickness		160	
Flange Material		SA-105	
Flange Type		Weld Neck Flange	
Corrosion Allowance	can	3.0000	mm
Joint Efficiency of Shell Seam at Nozzle	E1	1.00	
Joint Efficiency of Nozzle Neck	En	1.00	
Outside Projection	ho	74.0000	mm
Weld leg size between Nozzle and Pad/Shell	Wo	6.0000	mm
Groove weld depth between Nozzle and Vessel Wgnv		8.3400	mm
Flange Class		300	
Flange Grade		GR 1.1	

The Pressure Design option was Design Pressure + static head.

Nozzle Sketch (may not represent actual weld type/configuration)

Pulsation damper outlet

C220006CLC008

Static Calculation

PV Elite 24 SP1 Licensee: PPV-Engineering B.V.

FileName : Instrument air outlet_LI4732 -----

Nozzle Calcs.: N2 Nozl: 13 9:30am Jun 21,2022

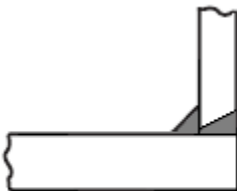
**Abutting/Set-on Nozzle No Pad****Reinforcement CALCULATION, Description: N2**

ASME Code, Section VIII, Div. 1, 2021, UG-37 to UG-45

Actual Outside Diameter Used in Calculation	60.325 mm.
Actual Thickness Used in Calculation	8.738 mm

Nozzle input data check completed without errors.

Reqd thk per UG-37(a) of Cylindrical Shell, tr [Int. Press]

$$= P \cdot R / (S_v \cdot E - 0.6 \cdot P) \text{ per UG-27 (c)(1)}$$

$$= 2.4 \cdot 104.4 / (117.9 \cdot 1 - 0.6 \cdot 2.4)$$

$$= 2.1508 \text{ mm}$$

Reqd thk per UG-37(a) of Nozzle Wall, trn [Int. Press]

$$= P \cdot R_o / (S_n \cdot E + 0.4 \cdot P) \text{ per Appendix 1-1 (a)(1)}$$

$$= 2.4 \cdot 30.16 / (117.9 \cdot 1 + 0.4 \cdot 2.4)$$

$$= 0.6090 \text{ mm}$$

UG-40, Limits of Reinforcement : [Internal Pressure]

Parallel to Vessel Wall (Diameter Limit)	D1	97.6996 mm
Parallel to Vessel Wall, opening length	d	48.8498 mm
Normal to Vessel Wall (Thickness Limit), no pad	Tlnp	10.4000 mm

Taking a UG-36(c)(3)(a) exemption for nozzle: N2.

This calculation is valid for nozzles that meet all the requirements of paragraph UG-36. Please check the Code carefully, especially for nozzles that are not isolated or do not meet Code spacing requirements. To force the computation of areas for small nozzles go to Tools->Configuration and check the box to force the UG-37 small nozzle area calculation.

UG-45 Minimum Nozzle Neck Thickness Requirement: [Int. Press.]

Wall Thickness for Internal/External pressures	ta = 3.6090 mm
Wall Thickness per UG16(b),	tr16b = 4.5000 mm
Wall Thickness, shell/head, internal pressure	trb1 = 5.1508 mm
Wall Thickness	tb1 = max(trb1, tr16b) = 5.1508 mm
Wall Thickness	tb2 = max(trb2, tr16b) = 4.5000 mm
Wall Thickness per table UG-45	tb3 = 6.4200 mm

Determine Nozzle Thickness candidate [tb]:

$$= \min[tb3, \max(tb1, tb2)]$$

$$= \min[6.42, \max(5.151, 4.5)]$$

$$= 5.1508 \text{ mm}$$

Minimum Wall Thickness of Nozzle Necks [tUG-45]:

$$= \max(ta, tb)$$

Pulsation damper outlet
C220006CLC008

Static Calculation

PV Elite 24 SP1 Licensee: PPV-Engineering B.V.

FileName : Instrument air outlet_LI4732 -----

Nozzle Calcs.: N2 Nozl: 13 9:30am Jun 21, 2022

$$= \max(3.609, 5.151)$$

$$= 5.1508 \text{ mm}$$

Available Nozzle Neck Thickness = $0.875 * 8.738 = 7.645 \text{ mm}$ --> OK

Nozzle Junction Minimum Design Metal Temperature (MDMT) Calculations:

Nozzle Neck to Flange Weld, min(Curve:B, Curve:A)

Govrn. thk, tg = 7.645, tr = 0.609, c = 3 mm, E* = 1
Thickness Ratio = $tr * E*/(tg - c) = 0.131$, Temp. Reduction = 78 °C

Min Metal Temp. w/o impact per UCS-66, Curve A	-8 °C
Min Metal Temp. at Required thickness (UCS 66.1)	-104 °C
Min Metal Temp. w/o impact per UG-20(f)	-29 °C

Nozzle-Shell/Head Weld (UCS-66(a)1(b)), Curve: B

Govrn. thk, tg = 7.16, tr = 2.151, c = 3 mm, E* = 1
Thickness Ratio = $tr * E*/(tg - c) = 0.517$, Temp. Reduction = 30 °C

Min Metal Temp. w/o impact per UCS-66, Curve B	-29 °C
Min Metal Temp. at Required thickness (UCS 66.1)	-48 °C

Gov. MDMT of the nozzle to shell joint welded assembly : -48 °C

Flange MDMT including Temperature reduction per UCS-66.1:

Unadjusted MDMT of ASME B16.5/47 flanges per UCS-66(c)	-18 °C
Flange MDMT with Temp reduction per UCS-66(b)(1)(-b)	-48 °C

Where the Stress Reduction Ratio per UCS-66(b)(1)(-b) is :
Design Pressure/Ambient Rating = $2.40/5.11 = 0.470$

Weld Size Calculations, Description: N2

Intermediate Calc. for nozzle/shell Welds Tmin 5.1800 mm

Results Per UW-16.1:

	Required Thickness	Actual Thickness
Nozzle Weld	$3.6260 = 0.7 * t_{min}$	$4.2420 = 0.7 * W_o$ mm

Skipping the nozzle attachment weld strength calculations. Per UW-15(b)(2) the nozzles exempted by UG-36(c)(3)(a) (small nozzles) do not require a weld strength check.

Maximum Allowable Pressure for this Nozzle at this Location:

Converged Maximum Allowable Pressure in the Operating case: 3.864 MPa

Note: The MAWP of this junction was limited by the parent Shell/Head.

The Drop for this Nozzle is : 4.5914 mm

The Cut Length for this Nozzle is, Drop + Ho + H + T : 85.7514 mm

PV Elite is a trademark of Hexagon AB, 2022, All rights reserved.

Pulsation damper outlet
C220006CLC008

Static Calculation

PV Elite 24 SP1 Licensee: PPV-Engineering B.V.

FileName : Instrument air outlet_LI4732 -----

Nozzle Calcs.: N3 Nozl: 14 9:30am Jun 21,2022

Input, Nozzle Desc: N3 From: 20

Pressure for Reinforcement Calculations	P	2.4000	MPa
Temperature for Internal Pressure	Temp	210	°C
Parent Material		SA-106 B	
Parent Allowable Stress at Temperature	Sv	117.90	MPa
Parent Allowable Stress At Ambient	Sva	117.90	MPa
Inside Diameter of Cylindrical Shell	D	202.74	mm
Shell Finished (Minimum) Thickness	t	7.1600	mm
Shell Internal Corrosion Allowance	c	3.0000	mm
Shell External Corrosion Allowance	co	0.0000	mm
Distance from Bottom/Left Tangent		201.31	mm
User Entered Minimum Design Metal Temperature		-28.89	°C

Type of Element Connected to the Parent : Nozzle

Material		SA-106 B	
Material UNS Number		K03006	
Material Specification/Type		Smls. pipe	
Allowable Stress at Temperature	Sn	117.90	MPa
Allowable Stress At Ambient	Sna	117.90	MPa
Diameter Basis (for tr calc only)		Outside	
Layout Angle		270.00	deg
Diameter		38.1000	mm
Size and Thickness Basis		Actual	
Actual Thickness	tn	8.3820	mm
Corrosion Allowance	can	3.0000	mm
Joint Efficiency of Shell Seam at Nozzle	E1	1.00	
Joint Efficiency of Nozzle Neck	En	1.00	
Outside Projection	ho	47.6250	mm
Weld leg size between Nozzle and Pad/Shell	Wo	6.0000	mm
Groove weld depth between Nozzle and Vessel Wgnv		8.3400	mm

The Pressure Design option was Design Pressure + static head.

Nozzle Sketch (may not represent actual weld type/configuration)

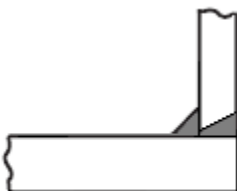

Abutting/Set-on Nozzle No Pad

Pulsation damper outlet
C220006CLC008

Static Calculation

PV Elite 24 SP1 Licensee: PPV-Engineering B.V.

FileName : Instrument air outlet_LI4732 -----

Nozzle Calcs.: N3 Nozl: 14 9:30am Jun 21, 2022

Reinforcement CALCULATION, Description: N3

ASME Code, Section VIII, Div. 1, 2021, UG-37 to UG-45

Actual Outside Diameter Used in Calculation	38.100 mm.
Actual Thickness Used in Calculation	8.382 mm

Nozzle input data check completed without errors.

Reqd thk per UG-37(a) of Cylindrical Shell, tr [Int. Press]

$$= P \cdot R / (S_v \cdot E - 0.6 \cdot P) \text{ per UG-27 (c)(1)}$$

$$= 2.4 \cdot 104.4 / (117.9 \cdot 1 - 0.6 \cdot 2.4)$$

$$= 2.1508 \text{ mm}$$

Reqd thk per UG-37(a) of Nozzle Wall, trn [Int. Press]

$$= P \cdot R_o / (S_n \cdot E + 0.4 \cdot P) \text{ per Appendix 1-1 (a)(1)}$$

$$= 2.4 \cdot 19.05 / (117.9 \cdot 1 + 0.4 \cdot 2.4)$$

$$= 0.3846 \text{ mm}$$

UG-40, Limits of Reinforcement : [Internal Pressure]

Parallel to Vessel Wall (Diameter Limit)	D1	54.6720 mm
Parallel to Vessel Wall, opening length	d	27.3360 mm
Normal to Vessel Wall (Thickness Limit), no pad	Tlnp	10.4000 mm

Taking a UG-36(c)(3)(a) exemption for nozzle: N3.

This calculation is valid for nozzles that meet all the requirements of paragraph UG-36. Please check the Code carefully, especially for nozzles that are not isolated or do not meet Code spacing requirements. To force the computation of areas for small nozzles go to Tools->Configuration and check the box to force the UG-37 small nozzle area calculation.

UG-45 Minimum Nozzle Neck Thickness Requirement: [Int. Press.]

Wall Thickness for Internal/External pressures	ta = 3.3846 mm
Wall Thickness per UG16(b),	tr16b = 4.5000 mm
Wall Thickness, shell/head, internal pressure	trb1 = 5.1508 mm
Wall Thickness	tb1 = max(trb1, tr16b) = 5.1508 mm
Wall Thickness	tb2 = max(trb2, tr16b) = 4.5000 mm
Wall Thickness per table UG-45	tb3 = 6.1200 mm

Determine Nozzle Thickness candidate [tb]:

$$= \min[tb3, \max(tb1, tb2)]$$

$$= \min[6.12, \max(5.151, 4.5)]$$

$$= 5.1508 \text{ mm}$$

Minimum Wall Thickness of Nozzle Necks [tUG-45]:

$$= \max(ta, tb)$$

$$= \max(3.385, 5.151)$$

$$= 5.1508 \text{ mm}$$

Available Nozzle Neck Thickness = 8.3820 mm --> OK

Nozzle Junction Minimum Design Metal Temperature (MDMT) Calculations:

Nozzle-Shell/Head Weld (UCS-66(a)1(b)), Curve: B

Govrn. thk, tg = 7.16, tr = 2.151, c = 3 mm, E* = 1

Thickness Ratio = tr * E*/(tg - c) = 0.517, Temp. Reduction = 30 °C

Pulsation damper outlet

C220006CLC008

Static Calculation

PV Elite 24 SP1 Licensee: PPV-Engineering B.V.

FileName : Instrument air outlet_LI4732 -----

Nozzle Calcs.: N3 Nozl: 14 9:30am Jun 21,2022

Min Metal Temp. w/o impact per UCS-66, Curve B -29 °C

Min Metal Temp. at Required thickness (UCS 66.1) -48 °C

Gov. MDMT of the nozzle to shell joint welded assembly : -48 °C

Weld Size Calculations, Description: N3

Intermediate Calc. for nozzle/shell Welds Tmin 5.1800 mm

Results Per UW-16.1:

	Required Thickness	Actual Thickness
Nozzle Weld	3.6260 = 0.7 * tmin.	4.2420 = 0.7 * Wo mm

Skipping the nozzle attachment weld strength calculations. Per UW-15(b)(2) the nozzles exempted by UG-36(c)(3)(a) (small nozzles) do not require a weld strength check.

Maximum Allowable Pressure for this Nozzle at this Location:

Converged Maximum Allowable Pressure in the Operating case: 3.864 MPa

Note: The MAWP of this junction was limited by the parent Shell/Head.

The Drop for this Nozzle is : 1.8061 mm

The Cut Length for this Nozzle is, Drop + Ho + H + T : 56.5911 mm

PV Elite is a trademark of Hexagon AB, 2022, All rights reserved.

Pulsation damper outlet

C220006CLC008

Static Calculation

PV Elite 24 SP1 Licensee: PPV-Engineering B.V.

FileName : Instrument air outlet_LI4732 -----

Nozzle Calcs.: Noz N1 Nozl: 15 9:30am Jun 21,2022

Input, Nozzle Desc: Noz N1

From: 30

Pressure for Reinforcement Calculations	P	2.4000	MPa
Temperature for Internal Pressure	Temp	210	°C
Parent Material		SA-234	WPB
Parent Allowable Stress at Temperature	Sv	117.90	MPa
Parent Allowable Stress At Ambient	Sva	117.90	MPa
Inside Diameter of Elliptical Head	D	202.74	mm
Aspect Ratio of Elliptical Head	Ar	2.00	
Head Finished (Minimum) Thickness	t	8.1800	mm
Head Internal Corrosion Allowance	c	3.0000	mm
Head External Corrosion Allowance	co	0.0000	mm
Distance from Head Centerline	L1	0.0000	mm
User Entered Minimum Design Metal Temperature		-28.89	°C

Type of Element Connected to the Parent : Nozzle

Material		SA-106 B	
Material UNS Number		K03006	
Material Specification/Type		Smls. pipe	
Allowable Stress at Temperature	Sn	117.90	MPa
Allowable Stress At Ambient	Sna	117.90	MPa
Diameter Basis (for tr calc only)		Outside	
Layout Angle		0.00	deg
Diameter		50.0000	mm
Size and Thickness Basis		Nominal	
Nominal Thickness		160	
Flange Material		SA-105	
Flange Type		Weld Neck Flange	
Corrosion Allowance	can	3.0000	mm
Joint Efficiency of Shell Seam at Nozzle	E1	1.00	
Joint Efficiency of Nozzle Neck	En	1.00	
Outside Projection	ho	63.0000	mm
Weld leg size between Nozzle and Pad/Shell	Wo	6.0000	mm
Groove weld depth between Nozzle and Vessel Wgnv		7.1600	mm
Flange Class		300	
Flange Grade		GR 1.1	

The Pressure Design option was Design Pressure + static head.

Nozzle Sketch (may not represent actual weld type/configuration)

Pulsation damper outlet
C220006CLC008

Static Calculation

PV Elite 24 SP1 Licensee: PPV-Engineering B.V.

FileName : Instrument air outlet_LI4732 -----

Nozzle Calcs.: Noz N1 Nozl: 15 9:30am Jun 21, 2022

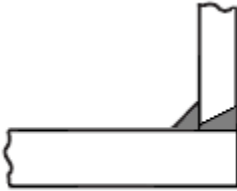

Abutting/Set-on Nozzle No Pad

Reinforcement CALCULATION, Description: Noz N1

ASME Code, Section VIII, Div. 1, 2021, UG-37 to UG-45

Actual Outside Diameter Used in Calculation	60.325 mm.
Actual Thickness Used in Calculation	8.738 mm

Nozzle input data check completed without errors.

Reqd thk per UG-37(a) of Elliptical Head, tr [Int. Press]
 = $P \cdot D \cdot K_1 / (2 \cdot S_v \cdot E - 0.2 \cdot P)$ per Appendix 1-4(c)
 = $0.876 \cdot 2.4 \cdot 208.7 / (2 \cdot 117.9 \cdot 1 - 0.2 \cdot 2.4)$
 = 1.8650 mm

Reqd thk per UG-37(a) of Nozzle Wall, trn [Int. Press]
 = $P \cdot R_o / (S_n \cdot E + 0.4 \cdot P)$ per Appendix 1-1 (a)(1)
 = $2.4 \cdot 30.16 / (117.9 \cdot 1 + 0.4 \cdot 2.4)$
 = 0.6090 mm

UG-40, Limits of Reinforcement : [Internal Pressure]

Parallel to Vessel Wall (Diameter Limit)	D1	97.6996 mm
Parallel to Vessel Wall, opening length	d	48.8498 mm
Normal to Vessel Wall (Thickness Limit), no pad	Tlnp	12.9500 mm

*Taking a UG-36(c)(3)(a) exemption for nozzle: Noz N1.
 This calculation is valid for nozzles that meet all the requirements of
 paragraph UG-36. Please check the Code carefully, especially for nozzles
 that are not isolated or do not meet Code spacing requirements. To force
 the computation of areas for small nozzles go to Tools->Configuration
 and check the box to force the UG-37 small nozzle area calculation.*

UG-45 Minimum Nozzle Neck Thickness Requirement: [Int. Press.]

Wall Thickness for Internal/External pressures	ta = 3.6090 mm
Wall Thickness per UG16(b),	tr16b = 4.5000 mm
Wall Thickness, shell/head, internal pressure	trb1 = 5.0506 mm
Wall Thickness	tb1 = max(trb1, tr16b) = 5.0506 mm
Wall Thickness	tb2 = max(trb2, tr16b) = 4.5000 mm
Wall Thickness per table UG-45	tb3 = 6.4200 mm

Determine Nozzle Thickness candidate [tb]:
 = min[tb3, max(tb1, tb2)]
 = min[6.42, max(5.051, 4.5)]
 = 5.0506 mm

Minimum Wall Thickness of Nozzle Necks [tUG-45]:
 = max(ta, tb)

Pulsation damper outlet
C220006CLC008

Static Calculation

PV Elite 24 SP1 Licensee: PPV-Engineering B.V.

FileName : Instrument air outlet_LI4732 -----

Nozzle Calcs.: Noz N1 Nozl: 15 9:30am Jun 21, 2022

$$= \max(3.609, 5.051)$$

$$= 5.0506 \text{ mm}$$

Available Nozzle Neck Thickness = $0.875 * 8.738 = 7.645 \text{ mm}$ --> OK

Nozzle Junction Minimum Design Metal Temperature (MDMT) Calculations:

Nozzle Neck to Flange Weld, Curve: B

Govrn. thk, tg = 7.645, tr = 0.609, c = 3 mm, E* = 1
Thickness Ratio = $tr * E*/(tg - c) = 0.131$, Temp. Reduction = 78 °C

Min Metal Temp. w/o impact per UCS-66, Curve B	-29 °C
Min Metal Temp. at Required thickness (UCS 66.1)	-104 °C

Nozzle-Shell/Head Weld (UCS-66(a)1(b)), Curve: B

Govrn. thk, tg = 7.645, tr = 0.609, c = 3 mm, E* = 1
Thickness Ratio = $tr * E*/(tg - c) = 0.131$, Temp. Reduction = 78 °C

Min Metal Temp. w/o impact per UCS-66, Curve B	-29 °C
Min Metal Temp. at Required thickness (UCS 66.1)	-104 °C

Gov. MDMT of the nozzle to shell joint welded assembly : -104 °C

Flange MDMT including Temperature reduction per UCS-66.1:

Unadjusted MDMT of ASME B16.5/47 flanges per UCS-66(c)	-18 °C
Flange MDMT with Temp reduction per UCS-66(b)(1)(-b)	-48 °C

Where the Stress Reduction Ratio per UCS-66(b)(1)(-b) is :
Design Pressure/Ambient Rating = $2.40/5.11 = 0.470$

Weld Size Calculations, Description: Noz N1

Intermediate Calc. for nozzle/shell Welds Tmin 5.1800 mm

Results Per UW-16.1:

	Required Thickness	Actual Thickness
Nozzle Weld	$3.6260 = 0.7 * t_{min}$	$4.2420 = 0.7 * W_o$ mm

Skipping the nozzle attachment weld strength calculations. Per UW-15(b)(2) the nozzles exempted by UG-36(c)(3)(a) (small nozzles) do not require a weld strength check.

Maximum Allowable Pressure for this Nozzle at this Location:

Converged Maximum Allowable Pressure in the Operating case: 4.83 MPa

Note: The MAWP of this junction was limited by the parent Shell/Head.

The Drop for this Nozzle is : 2.4222 mm

The Cut Length for this Nozzle is, Drop + Ho + H + T : 73.6022 mm

PV Elite is a trademark of Hexagon AB, 2022, All rights reserved.