





OWNER:  شرکت سست و سویی توهمه ایران (سهامی عامه)	<b>BUSHEHR PETROCHEMICAL COMPANY MEG PLANT</b>							EPC CONTRACTOR:  Chagalesh-Enerchimi-Steam Joint Venture BUPC-MEG PLANT PROJECT	
	<b>DATA SHEET &amp; DRAWINGS FOR STRAINERS FOR NITROGEN GAS BOOSTER</b>							 Netherlands	
MC :  شرکت سست و سویی توهمه ایران (سهامی عامه)	Project	Area	Phase	Unit	Dis.	Doc.	Seq.	Contract No : 52-98/445	
Owner Document Number: 17811-44A	BU	20	VD	303	ME	DSH	0031	Rev.:	Page
								03	1 of 6

## DATA SHEET & DRAWINGS FOR STRAINERS FOR NITROGEN GAS BOOSTER

Rev	Date	Purpose of Issue	Prepared	Checked	Approved	AC Code
03	14/12/2021	Approved for Construction	TvT	KP	LdM	
02	27/10/2021	For approval	TvT	KP	LdM	
01	20/09/2021	For approval	TvT	KP	LdM	
00	25/02/2021	For approval	TvT	KP	LdM	
Class: 1      Phase: P						



INDEX			
No.	Device	Tag Number	Page
1	Y-Strainer	No Tag.No: Qty 1 pcs	4
2	Y-Strainer	No Tag.No: Qty 1 pcs	5
3	Y-Strainer Drawing	No Tag.No.	6
4			
5			
6			
7			
8			
9			
10			
11			
12			
13			
14			
15			
16			
17			
18			
19			
20			
21			
22			
23			
24			
25			
26			
27			
28			
29			
30			
31			
32			
33			
34			
35			
36			
37			
38			
39			
40			
41			
42			
43			
44			
45			
46			
47			
48			
49			
50			
51			
52			
53			
54			
55			

**Notes:**

				<b>DATA SHEET &amp; DRAWINGS FOR STRAINERS FOR NITROGEN GAS BOOSTER</b>		Sheet <span style="float: right;">3 of 6</span> Based on P&ID <span style="float: right;">Rev.A</span>
03	TT	14-12-2021	Approved for Construction			
02	TT	27-10-2021	For Approval			
01	TT	20-9-2021	For Approval			
00	TT	25-2-2021	For Approval			
Rev	By	Date	Description			

GENERAL	1	Tag Number		No Tag.No: Qty 1 pc		
	2	Service		Y-strainer		
	3	P&ID No.		17811-03		
	4	Location		Compressor Inlet		
	5					
	6					
	7					
	8					
PROCESS CONDITIONS	9	Fluid	State		Nitrogen	Dry Gas
	10	Pressure	Norm.	Max.	8 Bar(a)	9 Bar(a)
	11	Temperature	Norm.	Max.	Ambient	Ambient
	12	Design	Press.	Temp.	13.5 Bar(a)	80°C
	13	Ambient Temp.	Min.	Max.	5 °C	55 °C
	14	Oper. Flow		707 Kg/hr / 565 Nm3/hr		
	15					
	16					
BODY	20	Type Of Body		Y-strainer		
	21	Connection		2" ANSI RF 150#		
	22	Body Material		A216 WCB		
	23	Mesh Material		SS 316		
	24	Mesh Size		3 mm		
	25					
	26					
	27					
	28					
	29					
	30					
	31					
	32					
	33					
	34					
	35					
	36					
	CERTIFICATES	47	3.1 Material certificate		Yes	
48						
49						
50						
51						
52						
PURCHASE	53	Manufacturer		Barton Firtop		
	54	Model		SDD/YLD/R150		
	55					
	56					
	57					

--	--	--	--

03	TT	14-12-2021	Approved for Construction		Sheet 4 of 6 Based on P&ID Rev.A
02	TT	27-10-2021	For Approval		
01	TT	20-9-2021	For Approval		
00	TT	25-2-2021	For Approval		
Rev	By	Date	Description		

GENERAL	1	Tag Number		No Tag.No: Qty 1 pc	
	2	Service		Y-strainer	
	3	P&ID No.		17811-03	
	4	Location		Compressor Cooling water inlet	
	5				
	6				
	7				
	8				
PROCESS CONDITIONS	9	Fluid	State		Water Liquid
	10	Pressure	Norm.	Max.	4,5 Bar(g) 5 Bar(g)
	11	Temperature	Norm.	Max.	35°C 45°C
	12	Design	Press.	Temp.	6 Bar(g) 60°C
	13	Ambient Temp.	Min.	Max.	5 °C 55 °C
	14	Oper. Flow		14,5 m3/hr	
	15				
	16				
	17				
	18				
BODY	20	Type Of Body		Y-strainer	
	21	Connection		1 1/2" ANSI RF 150#	
	22	Body Material		A216 WCB	
	23	Mesh Material		SS 316	
	24	Mesh Size		3 mm	
	25				
	26				
	27				
	28				
	29				
	30				
	31				
	32				
	33				
	34				
	35				
	36				
	37				
38					
39					
40					
41					
42					
43					
44					
45					
46					
CERTIFICATES	47	3.1 Material certificate		Yes	
	48				
	49				
	50				
	51				
	52				
PURCHASE	53	Manufacturer		Barton Firtop	
	54	Model		SDD/YLD/R150	
	55				
	56				
	57				

--	--	--	--

03	TT	14-12-2021	Approved for Construction		Sheet 5 of 6 Based on P&ID Rev.A
02	TT	27-10-2021	For Approval		
01	TT	20-9-2021	For Approval		
00	TT	25-2-2021	For Approval		
Rev	By	Date	Description		

## R/F - 150LB RATING LIGHT DUTY 'Y'-TYPE STRAINER

**Sizes:** ½" to 12" Nominal Bore

**Pressure:** ASME Class 150LB

- Features:**
- Integrally Cast Housing.
  - Bolted Cover c/w Drain Plug.
  - Red oxide Finish (Carbon Steel).
  - 3mm Perf. Screen as Standard.

- Options:**
- Special Gasket, Special Screen.
  - D.P. Tappings/Gauge.
  - Magnetic Screen Insert.
  - Flanged Drains / Drain Valves.
  - Special Finish / Linings.

**Standards:** PED 2014/68/EU.  
ASME B16.5 Flange Dimensions.  
EN 10204 / NACE Certification.  
Generally i.a.w. ASME VIII, Div. 1

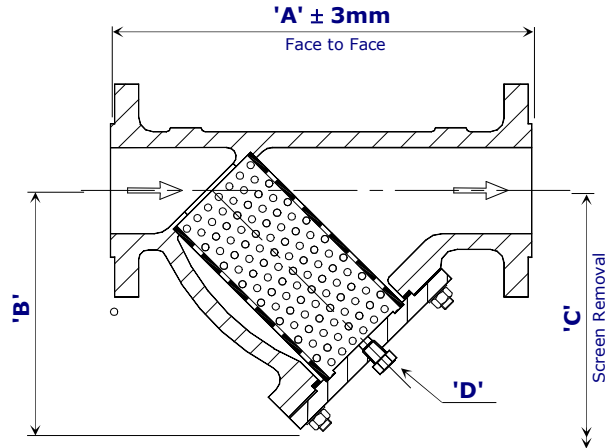

All data is subject to confirmation at the time of order. Our policy is one of continual improvement and we reserve the right to amend details without prior notice.

Size		Dimensions				Screen Area (cm <sup>2</sup> )	Weight (KG)
		'A' Face to Face	'B' Base to Centre line	'C' Screen Removal	'D' Drain (NPT)		
Inch	mm						
½"	15	170.0	95.0	165.0	½"	80.0	3.0
¾"	20	170.0	95.0	165.0	½"	80.0	4.0
1"	25	185.0	110.0	185.0	½"	126.5	6.0
1½"	40	270.0	140.0	230.0	½"	199.0	10.5
2"	50	275.0	180.0	285.0	½"	333.0	17.0
2½"	65	360.0	220.0	355.0	½"	574.5	27.5
3"	80	360.0	220.0	355.0	½"	574.5	29.5
4"	100	435.0	260.0	410.0	½"	923.4	49.0
6"	150	560.0	340.0	552.0	½"	1894.0	97.0
8"	200	655.0	440.0	705.0	¾"	2870.0	180.0
10"	250	880.0	600.0	1000.0	¾"	5000.0	340.0
12"	300	970.0	640.0	1040.0	¾"	6375.0	510.0