







| | | | | | | | | | |
|---|--|----|----|-----|----|-----|------|--|---------|
| OWNER:  شرکت سست و سویی گیس ایرپاک (سهامی خاص) | BUSHEHR PETROCHEMICAL COMPANY MEG PLANT | | | | | | | EPC CONTRACTOR:  Chagalesh-Enerchimi-Steam Joint Venture BUPC-MEG PLANT PROJECT | |
| | COMPRESSOR MOTOR OUTLINE DRAWING & TERMINAL BOX WIRING DIAGRAM FOR NITROGEN GAS BOOSTER | | | | | | |  | |
| MC : | | | | | | | |  شرکت سست و سویی گیس ایرپاک (سهامی خاص) | Project |
| Owner Document Number: 17811-39B | BU | 20 | VD | 303 | EL | DWG | 0101 | Rev.: | Page |
| | | | | | | | | 02 | 1 of 5 |

Repeated Comment:
Conflict!
Conflict shall be clarified.

**COMPRESSOR MOTOR OUTLINE DRAWING &
TERMINAL BOX WIRING DIAGRAM FOR EMERGENCY
INSTRUMENT AIR COMPRESSOR**

| | | |
|---|---|---|
|  شرکت سست و سویی گیس ایرپاک (سهامی خاص) |  Chagalesh-Enerchimi-Steam Joint Venture BUPC-MEG PLANT PROJECT | BUSHEHR PETROCHEMICAL COMPANY MEG PLANT |
| Document Review | | |
| Issue Purpose: | IFA | |
| Result Code: AP,AN,CM,RE,NC | AN | |
| Next Status : IFC,IFA,IFI,AFC,AB | AFC | |
| Responsible Department | MECHANICAL | |
| Commented Date | Jan /20/2022 | |
| Approval or review hereunder shall not be construed to relieve Vendor / Subcontractor of his responsibilities and liability under the contract. | | |

| | | | | | | |
|------|------------|------------------|----------|---------|----------|----------|
| | | | | | | |
| 02 | 06/01/2022 | For approval | KP | LdM | JR | |
| 01 | 10/12/2021 | For approval | KP | LdM | JR | |
| 00 | 08/12/2020 | For approval | KP | LdM | JR | |
| Rev. | Date | Purpose of Issue | Prepared | Checked | Approved | AC Code |
| | | | | | Class: 1 | Phase: P |

Emergency Instrument Air Compressor 20-C-7080-M

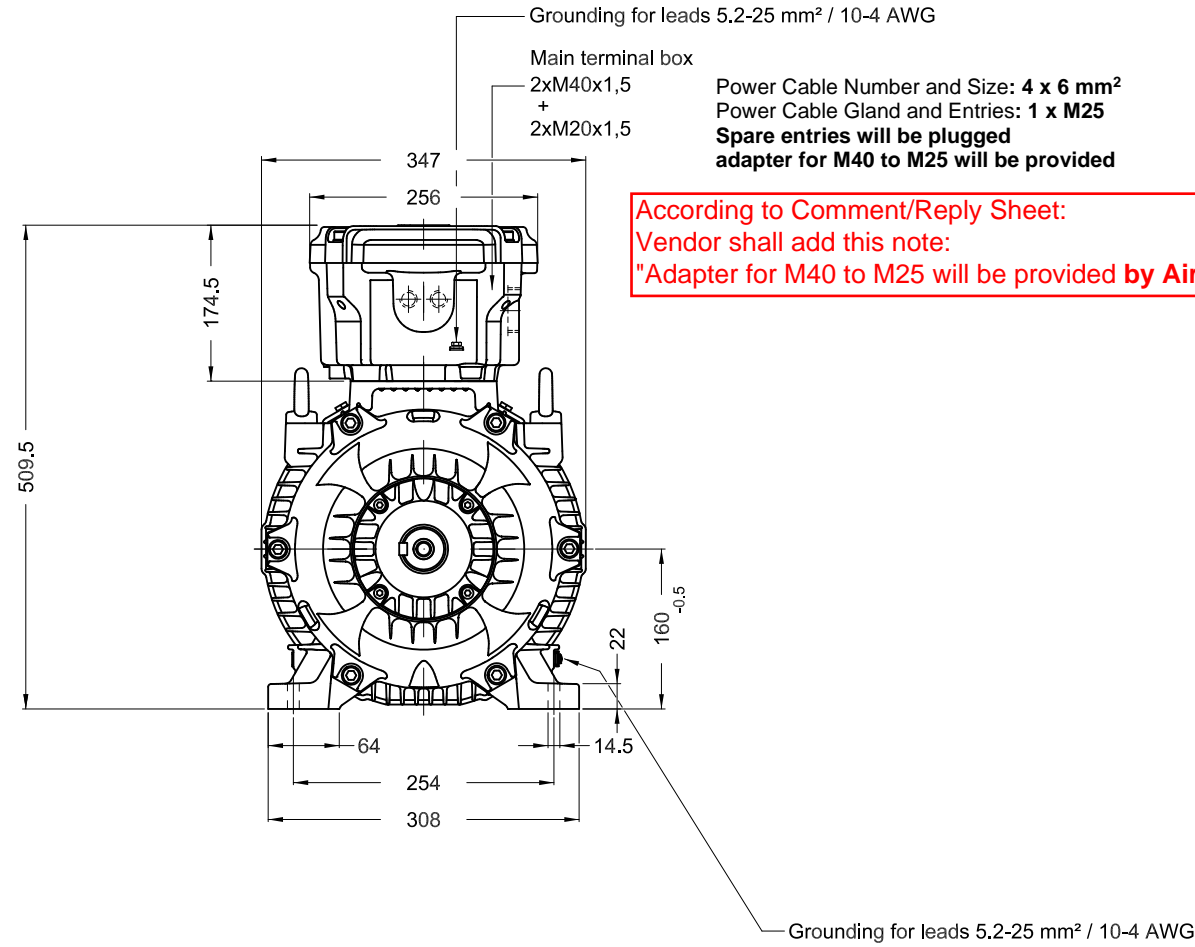

According to Comment/Reply Sheet:
Vendor shall add this note:
"Adapter for M40 to M25 will be provided by Airpack "

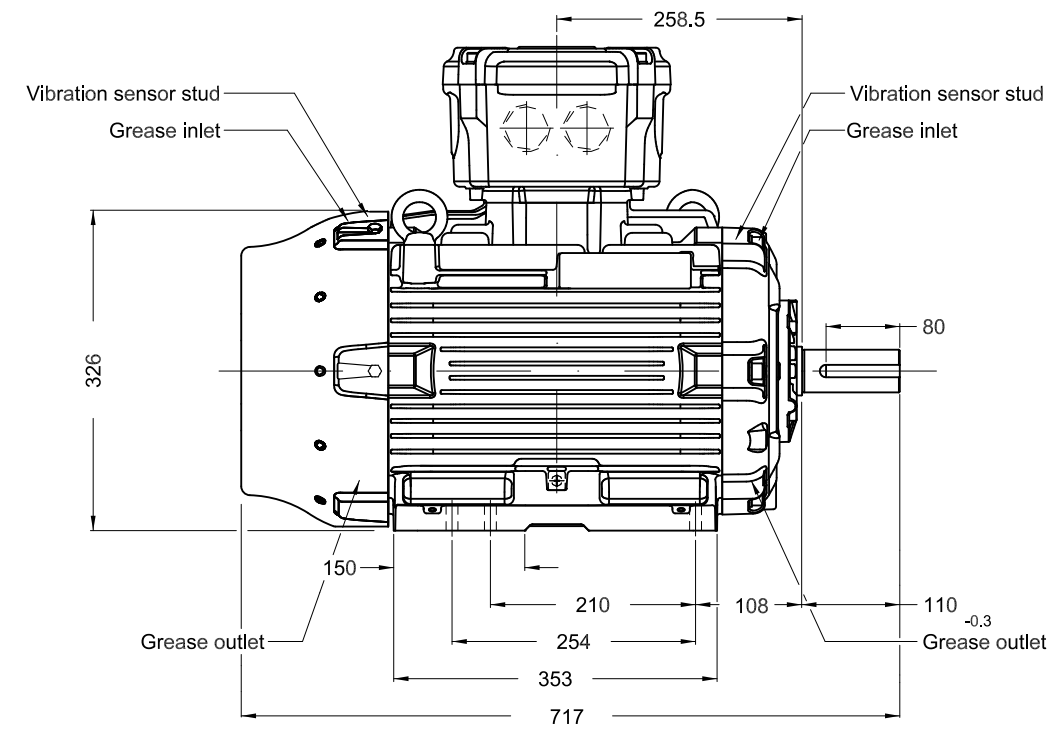

According to "Earthing SPEC.", Suitable earth cable size for this motor is **16mm²**.
Vendor is responsible for considering all necessary requirements.
Vendor shall confirm it in order to be closed this comment.

Grounding for leads 5.2-25 mm² / 10-4 AWG

- Tropicalized internal painting
- DE roller bearing
- Shaft locking device
- Shaft material - AISI/SAE 4140
- SPM studs
- Color RAL 5010
- Painting plan 205P
- Mounting B3T

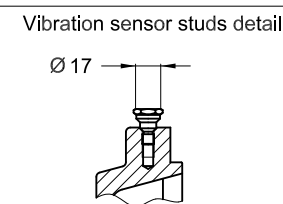
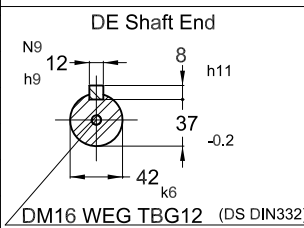

15 kW 04 Poles 50 Hz

AIRPACK B.V.

| | | | | | | | | | | |
|----------|------------|----------|--|--|-------|------------|----------|-----------|------------|-----|
| ECM | | LOC | DOCUMENTO NOVO 419034292 | | | MIRIANEV | WILLIANR | SIMONETTI | 06.12.2021 | 01 |
| EXECUTED | | PIRWUSER | SUMMARY OF MODIFICATIONS | | | EXECUTED | CHECKED | RELEASED | DATE | VER |
| CHECKED | NMAGNO | | THREE PH. MOTOR W22Xdb IE4 Ex d IIB T4 | FRAME 160M/L IP56 TEFC | | 1233471934 | | | | WEG |
| RELEASED | NMAGNO | | | Main Compressor Motor 20-C-7080-M 15kW | | WDD | 01 | | | |
| REL DT. | 23.11.2021 | WMO | Jaragua do Sul | Product Engineering | SHEET | 03/05 | | | | |

1 2 3 4 5 6

Dimensional drawing subject to change. We reserve the right to change constructional details.
 * Detail out of scale.

A
B
C
D
E

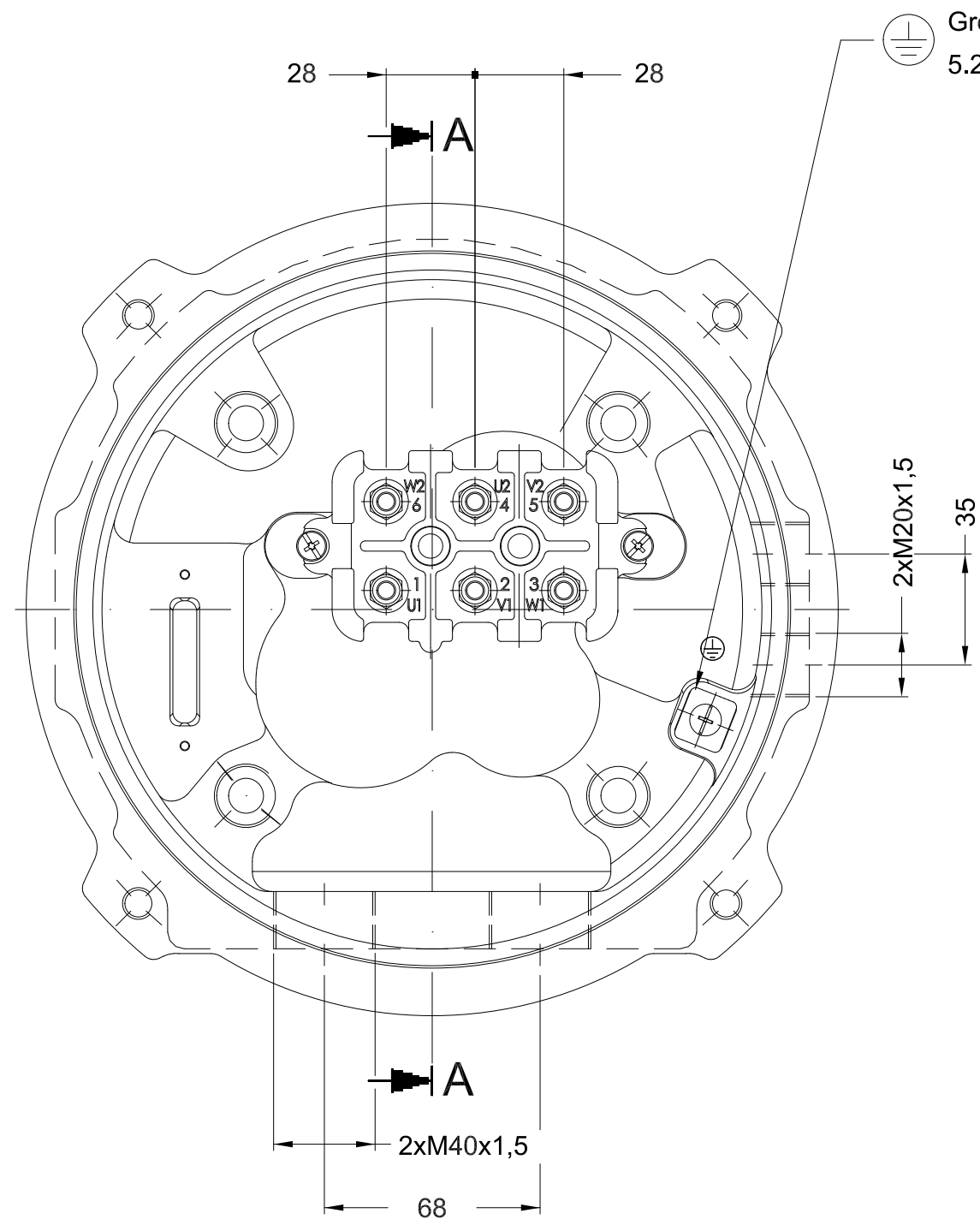

Grounding
 5.2-25mm² / 10-4AWG

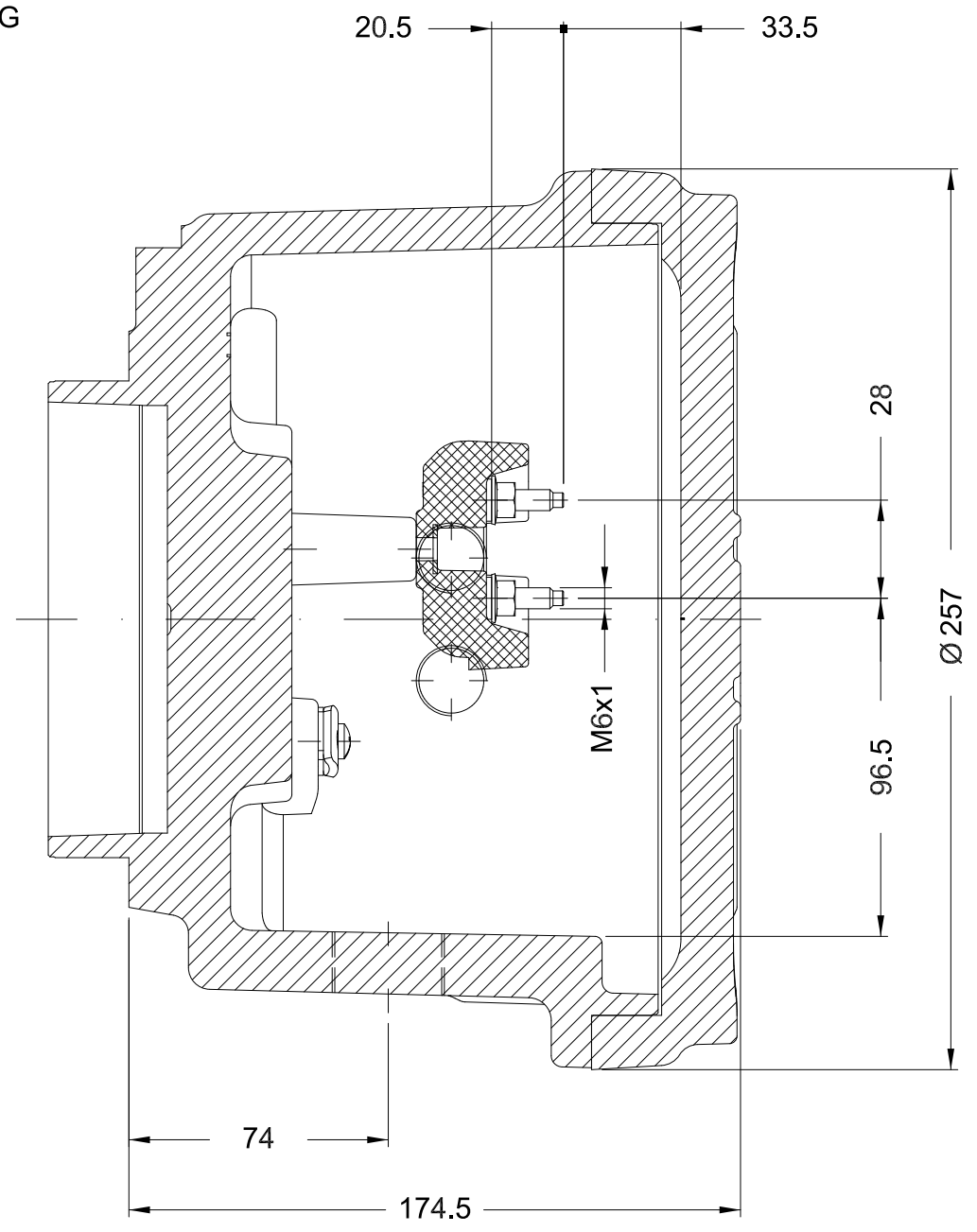

Section A-A

| | | | | | | | | | |
|----------|----------|--------------------------|--|--|----------|-----------|----------|------|-----|
| | | | | | | ESC | 1:2 | | |
| ECM | LOC | SUMMARY OF MODIFICATIONS | | | EXECUTED | CHECKED | RELEASED | DATE | VER |
| EXECUTED | YDAMHUIS | MAIN TERMINAL BOX | | | | | | | |
| CHECKED | | FRAME 160M/L | | | | | | | |
| RELEASED | | | | | | | | | |
| REL DT. | | | | | | | | | |
| | | | | | | PREVIEW | | | |
| | | | | | | WCD SHEET | | | |
| | | | | | | 04/05 | | | |

THIS IS AN UPDATED REVISION, THE PREVIOUS ONE MUST BE DISREGARDED.

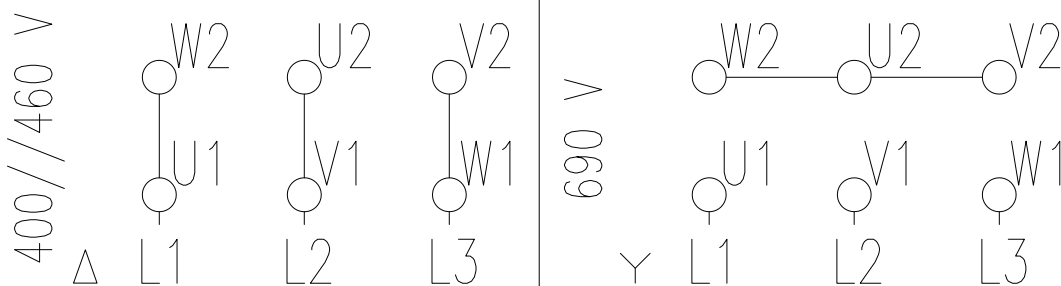

A

B

C

D

E

| | | | | | | | | |
|------------------|------------|--|---|-------------------------|-----------------------|----------------------|--------------|------------|
| | | ORIGINAL ISSUE | | JESSICA | PATRICIA | CASTELLA | 30.10.2018 | 00 |
| ECM | LOC | RESUMO MODIFICAÇÃO SUMMARY OF MODIFICATIONS | | EXECUTADO EXECUTED | VERIFICADO CHECKED | LIBERADO RELEASED | DATA DATE | VER VER |
| EXEC. /EXECUTED | JESSICA | | LOW VOLTAGE - CONNECTION DIAGRAM 400/690//460V MOTOR WITH 06 CABLES | 400/690//460-6 | | | | |
| VERIF. /CHECKED | PATRICIA | | | IEC | 00 | | | |
| LIBER. /RELEASED | CASTELLA | | | | | | | |
| DATA LB /REL DT | 30.10.2018 | WMO | JARAGUÁ DO SUL | ADMINISTRAÇÃO DE VENDAS | FOLHA /SHEET | 05/05 | | |