



LIDCO, Pars SEE Zone, Assaluyeh,
Integrated Methanol and Ammonia
Plant 3000 MTPD MeOH / 900 MTPD NH3 PROJECT



Detail Drawings for Pulsation Dampers

Document No. 17735-23B

Project No.	Vendor Doc.	P.O. No.	Department	Document Type	Serial No	Revision	Page
N278	VD	6019	ME	DWG	0025	06	Page 1 of 303

**Airpack B.V. - Air Compressor –
Integrated Methanol and Ammonia Plant
17735-COM Detail Drawings for Pulsation Dampers (K020)**

Code 2
M.Dalakeh

Previous comments are not applied. Previous document is sent again without any change. Check and implement comments.

06	18-12-2024	Issued for Approval	S.K.	J.J.	S.K.
05	21-10-2024	Issued for Approval	S.K.	J.J.	S.K.
04	15-10-2024	Issued for Approval	S.K.	J.J.	S.K.
03	16-09-2024	Issued for Approval	S.K.	J.J.	S.K.
02	15-05-2024	Issued for Approval	S.K.	J.J.	S.K.
01	21-02-2024	Issued for Approval	S.K.	J.J.	S.K.
REV.	DATE	DESCRIPTION	DRAWN	CHECKED	APPROVED

This document has been produced by Contractor for LIDCO. It is confidential and cannot be disclosed to or used by any third party for any purpose without prior written consent.

Detail Drawings for Pulsation Dampers

Document No. 17735-23B

Project No.	Vendor Doc.	P.O. No.	Department	Document Type	Serial No	Revision	Page
N278	VD	6019	ME	DWG	0025	06	Page 2 of 303

LIST OF REVISED PAGES

Rev. Page	01	02	03	04	05	06	07	08	09	10	Rev. Page	01	02	03	04	05	Rev. Page	01	02	03	04	05
1	X	X	X	X	X	X					51						76					
2	X	X	X	X	X	X					52						77					
3	X	X	X	X	X						53						78					
4	X	X	X	X	X						54						79					
5	X	X	X	X	X						55						80					
6	X	X	X	X	X						56						81					
7				X	X						57						82					
8				X	X						58						83					
9				X	X						59						84					
10				X	X						60						85					
11				X	X						61						86					
12				X	X						62						87					
13				X	X						63						88					
14				X	X						64						89					
15				X	X						65						90					
16				X	X						66						91					
17				X	X						67						98					
18				X	X						68						ATTACHMENT					
19				X	X						69						1					
20				X	X						70						2					
21				X	X						71						3					
22				X	X						72						4					
23				X	X						73						5					
24				X	X						74						6					
300				X	X	X					75						7					

Locati Impianti Srl

Via Vittorio Veneto, 37 - Verdellino - Bergamo - Italy

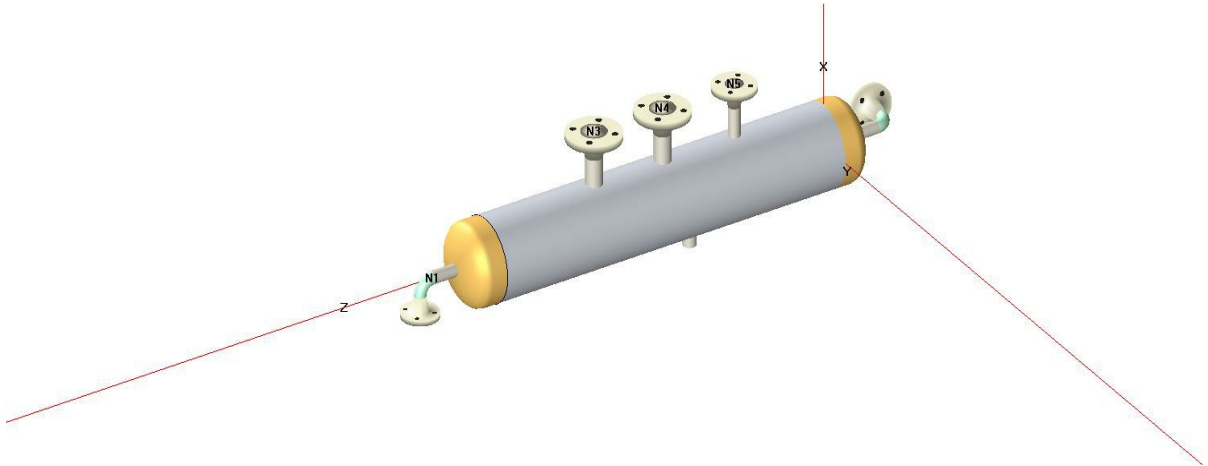

COMPRESS Pressure Vessel Design Calculations

Item: LI 5059

Customer: Airpack

Drawing No.: C230048DWG001

Document No.: C230048CLC005 Rev.02

Date: 04/08/2024

Service: 1st Stage Inlet Pulsation Damper

Tag Number: 320-KV-020-001

Table of Contents

Nozzle Schedule	1
Nozzle Summary	2
Pressure Summary	3
Settings Summary	4
Radiography Summary	6
Thickness Summary	7
Weight Summary	8
Hydrostatic Test	9
B16.9 Pipe Cap - Left Side	10
Straight Flange on B16.9 Pipe Cap - Left Side	12
Air Inlet (N1)	14
B16.9 Elbow #1 (N1)	21
Cylinder #1	24
Temperature Gauge Connection (N3)	26
Temperature Transmitter Connection (N4)	36
PSV Connection (N5)	46
Drain (N6)	56
Straight Flange on B16.9 Pipe Cap - Right Side	64
B16.9 Pipe Cap - Right Side	66
Air Outlet (N2)	68
B16.9 Elbow #2 (N2)	75

Nozzle Schedule

Specifications									
Nozzle mark	Identifier	Size	Materials		Impact Tested	Normalized	Fine Grain	Flange	Blind
N1	Air Inlet	NPS 1 Sch 160 DN 25	Nozzle	SA-106 B Smls Pipe	No	No	No	N/A	No
	B16.9 Elbow #1 (N1)	NPS 1 Sch 160 DN 25	B16.9 Elbow	SA-234 WPB	No	No	No	NPS 1 Class 150 WN A105	No
N2	Air Outlet	NPS 1 Sch 160 DN 25	Nozzle	SA-106 B Smls Pipe	No	No	No	N/A	No
	B16.9 Elbow #2 (N2)	NPS 1 Sch 160 DN 25	B16.9 Elbow	SA-234 WPB	No	No	No	NPS 1 Class 300 WN A105	No
N3	Temperature Gauge Connection	NPS 1,5 Sch 160 DN 40	Nozzle	SA-106 B Smls Pipe	No	No	No	NPS 1 1/2 Class 300 WN A105	No
N4	Temperature Transmitter Connection	NPS 1,5 Sch 160 DN 40	Nozzle	SA-106 B Smls Pipe	No	No	No	NPS 1 1/2 Class 300 WN A105	No
N5	PSV Connection	NPS 1 Sch 160 DN 25	Nozzle	SA-106 B Smls Pipe	No	No	No	NPS 1 Class 300 WN A105	No
N6	Drain	NPS 0,5 Class 6000 DN 15 - Threaded Full Coupling	Nozzle	SA-105	No	No	No	N/A	No

Nozzle Summary

Dimensions												
Nozzle mark	OD (mm)	t _n (mm)	Req t _n (mm)	A ₁ ?	A ₂ ?	Shell			Reinforcement Pad		Corr (mm)	A _a /A _r (%)
						Nom t (mm)	Design t (mm)	User t (mm)	Width (mm)	t _{pad} (mm)		
N1	33,4	6,35	6,35	Yes	Yes	8,18	N/A		N/A	N/A	3	Exempt
N2	33,4	6,35	6,35	Yes	Yes	8,18	N/A		N/A	N/A	3	Exempt
N3	48,26	7,14	7,11	Yes	Yes	8,18	N/A		N/A	N/A	3	Exempt
N4	48,26	7,14	7,11	Yes	Yes	8,18	N/A		N/A	N/A	3	Exempt
N5	33,4	6,35	6,35	Yes	Yes	8,18	N/A		N/A	N/A	3	Exempt
N6	38,1	8,38	4,5	Yes	Yes	8,18	N/A		N/A	N/A	3	Exempt

*Head minimum thickness after forming

Definitions	
t _n	Nozzle thickness
Req t _n	Nozzle thickness required per UG-45/UG-16 Increased for pipe to account for 12.5% pipe thickness tolerance
Nom t	Vessel wall thickness
Design t	Required vessel wall thickness due to pressure + corrosion allowance per UG-37
User t	Local vessel wall thickness (near opening)
A _a	Area available per UG-37, governing condition
A _r	Area required per UG-37, governing condition
Corr	Corrosion allowance on nozzle wall

Pressure Summary

Component Summary							
Identifier	P Design (bar)	T Design (°C)	MAWP (bar)	MAP (bar)	MDMT (°C)	MDMT Exemption	Impact Tested
B16.9 Pipe Cap - Left Side	12,5	75	40,92	69,64	-105	Note 1	No
Straight Flange on B16.9 Pipe Cap - Left Side	12,5	75	48,35	77,21	-105	Note 2	No
Cylinder #1	12,5	75	38,66	67,3	-48	Note 3	No
Straight Flange on B16.9 Pipe Cap - Right Side	12,5	75	48,35	77,21	-105	Note 2	No
B16.9 Pipe Cap - Right Side	12,5	75	40,92	69,64	-105	Note 4	No
Air Inlet (N1)	12,5	75	29,2	88,24	-105	Note 5	No
B16.9 Elbow #1 (N1)	12,5	75	18,45	19,6	-29	Note 6, 7	No
Air Outlet (N2)	12,5	75	29,2	88,24	-105	Note 5	No
B16.9 Elbow #2 (N2)	12,5	75	48,35	51,1	-48	Note 8, 9	No
Temperature Gauge Connection (N3)	12,5	75	45,49	51,1	-48	Note 10	No
Temperature Transmitter Connection (N4)	12,5	75	45,49	51,1	-48	Note 10	No
PSV Connection (N5)	12,5	75	27,8	51,1	-48	Note 10	No
Drain (N6)	12,5	75	45,49	79,18	-48	Note 11	No

Chamber Summary	
Design MDMT	0 °C
Rated MDMT	0 °C @ 18,45 bar
MAWP hot & corroded	18,45 bar @ 75 °C
MAP cold & new	19,6 bar @ 21,11 °C
(1) The rated MDMT is limited to the design MDMT based on the setting in the Calculations tab of the Set Mode dialog. (2) This pressure chamber is not designed for external pressure.	

Notes for MDMT Rating		
Note #	Exemption	Details
1.	Straight Flange governs MDMT	
2.	Material is impact test exempt to -105°C per UCS-66(b)(3) (coincident ratio = 0,3282)	
3.	Material impact test exemption temperature from Fig UCS-66M Curve B = -29°C Fig UCS-66.1M MDMT reduction = 48,8°C, (coincident ratio = 0,4089) Rated MDMT of -77,8°C is limited to -48°C by UCS-66(b)(2)	UCS-66 governing thickness = 7,16 mm
4.	Straight Flange governs MDMT	
5.	Nozzle is impact test exempt per UCS-66(d) (NPS 4 or smaller pipe).	
6.	Material is impact test exempt to -105°C per UCS-66(b)(3) (coincident ratio = 0,1525)	
7.	Flange rating governs: Flange rated MDMT per UG-20(f) = -29°C	Bolts rated MDMT per Fig UCS-66 note (c) = -48°C
8.	Material is impact test exempt to -105°C per UCS-66(b)(3) (coincident ratio = 0,1015)	
9.	Flange rating governs: Flange rated MDMT per UCS-66(b)(1)(b) = -48°C (Coincident ratio = 0,3611)	Bolts rated MDMT per Fig UCS-66 note (c) = -48°C
10.	Flange rating governs: Flange rated MDMT per UCS-66(b)(1)(b) = -48°C (Coincident ratio = 0,3611) Bolts rated MDMT per Fig UCS-66 note (c) = -48°C	
11.	Nozzle impact test exemption temperature from Fig UCS-66M Curve B = -29°C Fig UCS-66.1M MDMT reduction = 48,6°C, (coincident ratio = 0,4094) Rated MDMT of -77,6°C is limited to -48°C by UCS-66(b)(2)	UCS-66 governing thickness = 7,16 mm.

Settings Summary

COMPRESS 2024 Build 8400	
ASME Section VIII Division 1, 2021 Edition Metric	
Units	MKS
Datum Line Location	0,00 mm from right seam
Vessel Design Mode	Design Mode
Minimum thickness	1,5 mm per UG-16(b)
Design for cold shut down only	No
Design for lethal service (full radiography required)	No
Design nozzles for	Design P only
Corrosion weight loss	100% of theoretical loss
UG-23 Stress Increase	1,20
Skirt/legs stress increase	1,0
Minimum nozzle projection	60 mm
Juncture calculations for $\alpha > 30$ only	Yes
Preheat P-No 1 Materials $> 1,25"$ and $\leq 1,50"$ thick	No
UG-37(a) shell tr calculation considers longitudinal stress	No
Cylindrical shells made from pipe are entered as minimum thickness	No
Nozzles made from pipe are entered as minimum thickness	No
ASME B16.9 fittings are entered as minimum thickness	No
Butt welds	Tapered per Figure UCS-66.3(a)
Disallow Appendix 1-5, 1-8 calculations under 15 psi	No
Hydro/Pneumatic Test	
Shop Hydrotest Pressure	1,3 times vessel MAWP [UG-99(b)]
Test liquid specific gravity	1,00
Maximum stress during test	90% of yield
Required Marking - UG-116	
UG-116(e) Radiography	RT3
UG-116(f) Postweld heat treatment	None
Code Cases\Interpretations	
Use Appendix 46	No
Use UG-44(b)	No
Use Code Case 3035	No
Apply interpretation VIII-1-83-66	Yes
Apply interpretation VIII-1-86-175	Yes
Apply interpretation VIII-1-01-37	Yes
Apply interpretation VIII-1-01-150	Yes
Apply interpretation VIII-1-07-50	Yes
Apply interpretation VIII-1-16-85	Yes
No UCS-66.1 MDMT reduction	No
No UCS-68(c) MDMT reduction	No
Disallow UG-20(f) exemptions	No
UG-22 Loadings	
UG-22(a) Internal or External Design Pressure	Yes
UG-22(b) Weight of the vessel and normal contents under operating or test conditions	No
UG-22(c) Superimposed static reactions from weight of attached equipment (external loads)	No
UG-22(d)(2) Vessel supports such as lugs, rings, skirts, saddles and legs	No
UG-22(f) Wind reactions	No
UG-22(f) Seismic reactions	No
UG-22(j) Test pressure and coincident static head acting during the test:	No

Note: UG-22(b),(c) and (f) loads only considered when supports are present.

Note 2: UG-22(d)(1),(e),(f)-snow,(g),(h),(i) are not considered. If these loads are present, additional calculations must be performed.

License Information	
Company Name	Locati Impianti s.r.l.
License	Commercial
License Key ID	32235
Support Expires	September 20, 2024
Account Number	891888909529634

Radiography Summary

UG-116 Radiography							
Component	Longitudinal Seam		Left Circumferential Seam		Right Circumferential Seam		Mark
	Category (Fig UW-3)	Radiography / Joint Type	Category (Fig UW-3)	Radiography / Joint Type	Category (Fig UW-3)	Radiography / Joint Type	
B16.9 Pipe Cap - Left Side	N/A	Seamless No RT	N/A	N/A	B	Spot UW-11(b) / Type 1	RT3
Cylinder #1	N/A	Seamless No RT	B	Spot UW-11(b) / Type 1	B	Spot UW-11(b) / Type 1	RT3
B16.9 Pipe Cap - Right Side	N/A	Seamless No RT	B	Spot UW-11(b) / Type 1	N/A	N/A	RT3
Nozzle	Longitudinal Seam		Nozzle to Vessel Circumferential Seam		Nozzle free end Circumferential Seam		
Air Inlet (N1)	N/A	Seamless No RT	D	N/A / Type 7	B	UW-11(b) exempt / Type 1	N/A
B16.9 Elbow #1 (N1)	N/A	Seamless No RT	B	UW-11(b) exempt / Type 1	C	UW-11(b) exempt / Type 1	N/A
Temperature Gauge Connection (N3)	N/A	Seamless No RT	D	N/A / Type 7	C	UW-11(b) exempt / Type 1	N/A
Temperature Transmitter Connection (N4)	N/A	Seamless No RT	D	N/A / Type 7	C	UW-11(b) exempt / Type 1	N/A
PSV Connection (N5)	N/A	Seamless No RT	D	N/A / Type 7	C	UW-11(b) exempt / Type 1	N/A
Drain (N6)	N/A	Seamless No RT	D	N/A / Type 7	N/A	N/A	N/A
Air Outlet (N2)	N/A	Seamless No RT	D	N/A / Type 7	B	UW-11(b) exempt / Type 1	N/A
B16.9 Elbow #2 (N2)	N/A	Seamless No RT	B	UW-11(b) exempt / Type 1	C	UW-11(b) exempt / Type 1	N/A
Nozzle Flange	Longitudinal Seam		Flange Face		Nozzle to Flange Circumferential Seam		
ASME B16.5/16.47 flange attached to right end of B16.9 Elbow #1 (N1)	N/A	Seamless No RT	N/A	N/A / Gasketed	C	UW-11(b) exempt / Type 1	N/A
ASME B16.5/16.47 flange attached to Temperature Gauge Connection (N3)	N/A	Seamless No RT	N/A	N/A / Gasketed	C	UW-11(b) exempt / Type 1	N/A
ASME B16.5/16.47 flange attached to Temperature Transmitter Connection (N4)	N/A	Seamless No RT	N/A	N/A / Gasketed	C	UW-11(b) exempt / Type 1	N/A
ASME B16.5/16.47 flange attached to PSV Connection (N5)	N/A	Seamless No RT	N/A	N/A / Gasketed	C	UW-11(b) exempt / Type 1	N/A
ASME B16.5/16.47 flange attached to right end of B16.9 Elbow #2 (N2)	N/A	Seamless No RT	N/A	N/A / Gasketed	C	UW-11(b) exempt / Type 1	N/A
UG-116(e) Required Marking: RT3							

Thickness Summary

Component Data								
Component Identifier	Material	Diameter (mm)	Length (mm)	Nominal t (mm)	Design t (mm)	Total Corrosion (mm)	Joint E	Load
B16.9 Pipe Cap - Left Side	SA-234 WPB	219,07 OD	57,83	8,18	4,3	3	0,85	Internal
Straight Flange on B16.9 Pipe Cap - Left Side	SA-234 WPB	219,07 OD	44,16	8,18	4,36	3	0,85	Internal
Cylinder #1	SA-106 B Smls Pipe	219,07 OD	1.060	8,18	4,36	3	0,85	Internal
Straight Flange on B16.9 Pipe Cap - Right Side	SA-234 WPB	219,07 OD	44,16	8,18	4,36	3	0,85	Internal
B16.9 Pipe Cap - Right Side	SA-234 WPB	219,07 OD	57,83	8,18	4,3	3	0,85	Internal

Definitions	
Nominal t	Vessel wall nominal thickness
Design t	Required vessel thickness due to governing loading + corrosion
Joint E	Longitudinal seam joint efficiency
Load	
Internal	Circumferential stress due to internal pressure governs
External	External pressure governs
Wind	Combined longitudinal stress of pressure + weight + wind governs
Seismic	Combined longitudinal stress of pressure + weight + seismic governs

Weight Summary

Weight (kg) Contributed by Vessel Elements											
Component	Metal New*	Metal Corroded	Insulation	Insulation Supports	Lining	Piping + Liquid	Operating Liquid		Test Liquid		Surface Area m ²
							New	Corroded	New	Corroded	
B16.9 Pipe Cap - Left Side	5,2	3,4	0	0	0	0	0	0	2,6	2,8	0,09
Cylinder #1	44,6	28,7	0	0	0	0	0	0	34,4	36,5	0,72
B16.9 Pipe Cap - Right Side	5,2	3,4	0	0	0	0	0	0	2,6	2,8	0,09
TOTAL:	55	35,4	0	0	0	0	0	0	39,5	42,1	0,9

*Shells with attached nozzles have weight reduced by material cut out for opening.

Weight (kg) Contributed by Attachments										
Component	Body Flanges		Nozzles & Flanges		Packed Beds	Trays	Tray Supports	Rings & Clips	Vertical Loads	Surface Area m ²
	New	Corroded	New	Corroded						
B16.9 Pipe Cap - Left Side	0	0	1,9	1,7	0	0	0	0	0	0,03
Cylinder #1	0	0	10	9,3	0	0	0	0	0	0,15
B16.9 Pipe Cap - Right Side	0	0	2,4	2,1	0	0	0	0	0	0,04
TOTAL:	0	0	14,3	13,1	0	0	0	0	0	0,22

Vessel Totals		
	New	Corroded
Operating Weight (kg)	69	49
Empty Weight (kg)	69	49
Test Weight (kg)	109	91
Surface Area (m ²)	1,12	-
Capacity** (liters)	39	42

**The vessel capacity does not include volume of nozzle, piping or other attachments.

Vessel Lift Condition	
Vessel Lift Weight, New (kg)	69
Center of Gravity from Datum (mm)	527,16

Hydrostatic Test

Horizontal shop hydrostatic test based on MAWP per UG-99(b)

$$\begin{aligned}
 \text{Gauge pressure at } 21,11^{\circ}\text{C} &= 1,3 \cdot MAWP \cdot LSR \\
 &= 1,3 \cdot 18,45 \cdot 1 \\
 &= 23,99 \text{ bar}
 \end{aligned}$$

Horizontal shop hydrostatic test				
Identifier	Local test pressure (bar)	Test liquid static head (bar)	UG-99(b) stress ratio	UG-99(b) pressure factor
B16.9 Pipe Cap - Left Side (1)	24,02	0,03	1	1,30
Straight Flange on B16.9 Pipe Cap - Left Side	24,02	0,03	1	1,30
Cylinder #1	24,02	0,03	1	1,30
Straight Flange on B16.9 Pipe Cap - Right Side	24,02	0,03	1	1,30
B16.9 Pipe Cap - Right Side	24,02	0,03	1	1,30
Air Inlet (N1)	24,01	0,03	1	1,30
Air Outlet (N2)	24,01	0,03	1	1,30
B16.9 Elbow #1 (N1)	24,01	0,03	1	1,30
B16.9 Elbow #2 (N2)	24,01	0,03	1	1,30
Drain (N6)	24,02	0,04	1	1,30
PSV Connection (N5)	24	0,01	1	1,30
Temperature Gauge Connection (N3)	24	0,01	1	1,30
Temperature Transmitter Connection (N4)	24	0,01	1	1,30
(1) B16.9 Pipe Cap - Left Side limits the UG-99(b) stress ratio. (2) The zero degree angular position is assumed to be up, and the test liquid height is assumed to the top-most flange.				

The field test condition has not been investigated.

The test temperature of 21,11 °C is warmer than the minimum recommended temperature of -31 °C so the brittle fracture provision of UG-99(h) has been met.

B16.9 Pipe Cap - Left Side

ASME Section VIII Division 1, 2021 Edition Metric				
Component		ASME B16.9 Pipe Cap (modified)		
Material		SA-234 WPB (II-D Metric p. 16, In. 18)		
Attached To		Cylinder #1		
Impact Tested	Normalized	Fine Grain Practice	PWHT	Maximize MDMT/ No MAWP
No	No	No	No	No
		Design Pressure (bar)	Design Temperature (°C)	Design MDMT (°C)
Internal		12,5	75	0
Static Liquid Head				
Condition		P_s (bar)	H_s (mm)	SG
Test horizontal		0,03	351,36	1
Dimensions				
NPS and Schedule		NPS 8 Sch 40 (Std) DN 200		
Outer Diameter		219,07 mm		
Overall Length E		102 mm		
Nominal Thickness		8,18 mm		
Minimum Thickness¹		7,16 mm		
Corrosion	Inner	3 mm		
	Outer	0 mm		
Length L_{sf}		44,17 mm		
Nominal Thickness t_{sf}		8,18 mm		
Weight and Capacity				
		Weight (kg)²	Capacity (liters)²	
New		5,17	2,52	
Corroded		3,36	2,74	
Radiography				
Category A joints		Seamless No RT		
Head to shell seam		Spot UW-11(b) Type 1		

¹ minimum thickness = nominal thickness times pipe tolerance factor of 0,875.

² includes straight flange

Results Summary	
Governing condition	UG-16
Minimum thickness per UG-16	1,5 mm + 3 mm = 4,5 mm
Design thickness due to internal pressure (t)	4,3 mm
Governing straight flange design thickness	4,36 mm
Maximum allowable working pressure (MAWP)	40,92 bar
Maximum allowable pressure (MAP)	69,64 bar
<u>Straight Flange</u> governs MDMT	-105°C

Factor K		
	$K = \left(\frac{1}{6}\right) \cdot \left[2 + \left(\frac{D}{2 \cdot h}\right)^2\right]$	
Corroded	$K = \left(\frac{1}{6}\right) \cdot \left[2 + \left(\frac{208,71}{2 \cdot 53,68}\right)^2\right]$	0,9633
New	$K = \left(\frac{1}{6}\right) \cdot \left[2 + \left(\frac{202,71}{2 \cdot 50,68}\right)^2\right]$	1

Design thickness for internal pressure, (Corroded at 75 °C) Appendix 1-4(c)

$$t = \frac{P \cdot D_o \cdot K}{2 \cdot S \cdot E + 2 \cdot P \cdot (K - 0,1)} + \text{Corrosion} = \frac{12,5 \cdot 219,07 \cdot 0,963264}{2 \cdot 1.180 \cdot 0,85 + 2 \cdot 12,5 \cdot (0,963264 - 0,1)} + 3 = 4.3 \text{ mm}$$

Maximum allowable working pressure, (Corroded at 75 °C) Appendix 1-4(c)

$$P = \frac{2 \cdot S \cdot E \cdot t}{K \cdot D_o - 2 \cdot t \cdot (K - 0,1)} - P_s = \frac{2 \cdot 1.180 \cdot 0,85 \cdot (0,875 \cdot 8,18 - 3)}{0,963264 \cdot 219,07 - 2 \cdot (0,875 \cdot 8,18 - 3) \cdot (0,963264 - 0,1)} - 0 = 40.92 \text{ bar}$$

Maximum allowable pressure, (New at 21,11 °C) Appendix 1-4(c)

$$P = \frac{2 \cdot S \cdot E \cdot t}{K \cdot D_o - 2 \cdot t \cdot (K - 0,1)} - P_s = \frac{2 \cdot 1.180 \cdot 0,85 \cdot 0,875 \cdot 8,18}{1 \cdot 219,07 - 2 \cdot 0,875 \cdot 8,18 \cdot (1 - 0,1)} - 0 = 69.64 \text{ bar}$$

ASME Section VIII Division 1 UG-81(a) Out-of-Roundness
Inside surface shall not deviate outside the shape by more than 1,25 % of D
Inside surface shall not deviate inside the shape by more than 0,625 % of D

Straight Flange on B16.9 Pipe Cap - Left Side

ASME Section VIII Division 1, 2021 Edition Metric				
Component		Cylinder		
Material		SA-234 WPB (II-D Metric p. 16, ln. 18)		
Impact Tested	Normalized	Fine Grain Practice	PWHT	Maximize MDMT/ No MAWP
No	No	No	No	No
		Design Pressure (bar)	Design Temperature (°C)	Design MDMT (°C)
Internal		12,5	75	0
Static Liquid Head				
Condition		P_s (bar)	H_s (mm)	SG
Test horizontal		0,03	351,36	1
Dimensions				
Outer Diameter		219,07 mm		
Length		44,17 mm		
Nominal Thickness		8,18 mm		
Corrosion	Inner	3 mm		
	Outer	0 mm		
Weight and Capacity				
		Weight (kg)		Capacity (liters)
New		1,87		1,43
Corroded		1,2		1,51
Radiography				
Longitudinal seam		Seamless No RT		
Right Circumferential seam		Spot UW-11(b) Type 1		

Results Summary	
Governing condition	UG-16
Minimum thickness per UG-16	1,5 mm + 3 mm = 4,5 mm
Design thickness due to internal pressure (t)	4,36 mm
Maximum allowable working pressure (MAWP)	48,35 bar
Maximum allowable pressure (MAP)	77,21 bar
Rated MDMT	-105 °C

UCS-66 Material Toughness Requirements	
$t_r = \frac{18,45 \cdot 109,54}{1.180 \cdot 0,85 + 0,4 \cdot 18,45} =$	2 mm
Stress ratio = $\frac{t_r \cdot E^*}{t_n - c} = \frac{2 \cdot 0,85}{8,18 - 3} =$	0,3282
Stress ratio $\leq 0,35$, MDMT per UCS-66(b)(3) =	-105°C
Material is exempt from impact testing at the Design MDMT of 0°C.	

Design thickness, (at 75 °C) Appendix 1-1

$$t = \frac{P \cdot R_o}{S \cdot E + 0,40 \cdot P} + \text{Corrosion} = \frac{12,5 \cdot 109,54}{1.180 \cdot 0,85 + 0,40 \cdot 12,5} + 3 = \text{4,36 mm}$$

Maximum allowable working pressure, (at 75 °C) Appendix 1-1

$$P = \frac{S \cdot E \cdot t}{R_o - 0,40 \cdot t} - P_s = \frac{1.180 \cdot 0,85 \cdot 5,18}{109,54 - 0,40 \cdot 5,18} - 0 = \underline{48,35} \text{ bar}$$

Maximum allowable pressure, (at 21,11 °C) Appendix 1-1

$$P = \frac{S \cdot E \cdot t}{R_o - 0,40 \cdot t} = \frac{1.180 \cdot 0,85 \cdot 8,18}{109,54 - 0,40 \cdot 8,18} = \underline{77,21} \text{ bar}$$

ASME Section VIII Division 1 UG-80(a) Out-of-Roundness
$(D_{\max} - D_{\min})$ shall not exceed 1% of D
When the cross section passes through an opening or within 1 I.D. of the opening, $(D_{\max} - D_{\min})$ shall not exceed 1% of $D + 2\%$ of the inside diameter of the opening

Air Inlet (N1)

ASME Section VIII Division 1, 2021 Edition Metric

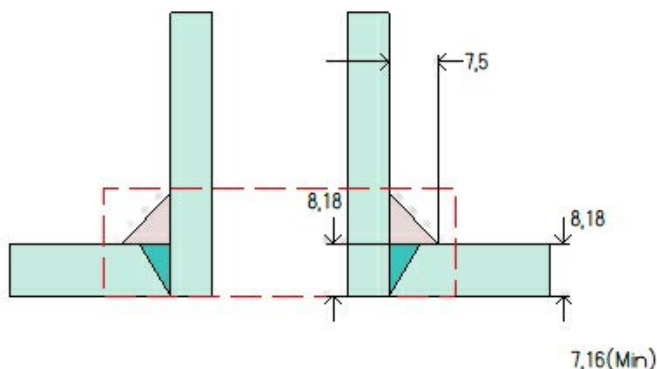

Note: round inside edges per UG-76(c)

Location and Orientation

Located on	B16.9 Pipe Cap - Left Side
Orientation	0°
End of nozzle to datum line	1.226 mm
Calculated as hillside	No
Distance to head center, R	0 mm
Passes through a Category A joint	No

Nozzle

Description	NPS 1 Sch 160 DN 25
Access opening	No
Material specification	SA-106 B Smls Pipe (II-D Metric p. 16, In. 16)
Inside diameter, new	20,7 mm
Pipe nominal wall thickness	6,35 mm
Pipe minimum wall thickness ¹	5,56 mm
Corrosion allowance	3 mm
Projection available outside vessel, L _{pr}	64,68 mm
Local vessel minimum thickness	7,16 mm
Liquid static head included	0 bar

Welds

Inner fillet, Leg ₄₁	7,5 mm
Nozzle to vessel groove weld	8,18 mm

Radiography

Longitudinal seam	Seamless No RT
Circumferential seam	Full UW-11(a) Type 1

¹Pipe minimum thickness = nominal thickness times pipe tolerance factor of 0,875.

UCS-66 Material Toughness Requirements Nozzle

Impact test exempt per UCS-66(d) (NPS 4 or smaller pipe) =	-105°C
Material is exempt from impact testing at the Design MDMT of 0°C.	

Reinforcement Calculations for Internal Pressure

UG-37 Area Calculation Summary (cm ²)							UG-45 Summary (mm)	
For P = 12,5 bar @ 75 °C							The nozzle passes UG-45	
A required	A available	A ₁	A ₂	A ₃	A ₅	A welds	t _{req}	t _{min}
This nozzle is exempt from area calculations per UG-36(c)(3)(a)							4,5	5,56

UG-41 Weld Failure Path Analysis Summary
The nozzle is exempt from weld strength calculations per UW-15(b)(2)

UW-16 Weld Sizing Summary			
Weld description	Required weld throat size (mm)	Actual weld throat size (mm)	Status
Nozzle to shell fillet (Leg ₄₁)	2,35	5,25	weld size is adequate

Calculations for internal pressure 12,5 bar @ 75 °C

Parallel Limit of reinforcement per UG-40

$$\begin{aligned}
 L_R &= \max [d, R_n + (t_n - C_n) + (t - C)] \\
 &= \max [26,7, 13,35 + (6,35 - 3) + (7,16 - 3)] \\
 &= 26,7 \text{ mm}
 \end{aligned}$$

Outer Normal Limit of reinforcement per UG-40

$$\begin{aligned}
 L_H &= \min [2,5 \cdot (t - C), 2,5 \cdot (t_n - C_n) + t_e] \\
 &= \min [2,5 \cdot (7,16 - 3), 2,5 \cdot (6,35 - 3) + 0] \\
 &= 8,38 \text{ mm}
 \end{aligned}$$

Nozzle required thickness per UG-27(c)(1)

$$\begin{aligned}
 t_{rn} &= \frac{P \cdot R_n}{S_n \cdot E - 0,6 \cdot P} \\
 &= \frac{12,5 \cdot 13,35}{1.180 \cdot 1 - 0,6 \cdot 12,5} \\
 &= 0,14 \text{ mm}
 \end{aligned}$$

Required thickness t_r from UG-37(a)(c)

$$\begin{aligned}
 t_r &= \frac{P \cdot K_1 \cdot D_o}{2 \cdot S \cdot E + 0,8 \cdot P} \\
 &= \frac{12,5 \cdot 0,8749 \cdot 219,07}{2 \cdot 1.180 \cdot 1 + 0,8 \cdot 12,5} \\
 &= 1,01 \text{ mm}
 \end{aligned}$$

Required thickness t_r per Interpretation VIII-1-07-50

$$t_r = \frac{P \cdot D_o \cdot K}{2 \cdot S \cdot E + 2 \cdot P \cdot (K - 0,1)} = \frac{12,5 \cdot 219,07 \cdot 0,963264}{2 \cdot 1.180 \cdot 0,85 + 2 \cdot 12,5 \cdot (0,963264 - 0,1)} = 1,3 \text{ mm}$$

This opening does not require reinforcement per UG-36(c)(3)(a)

UW-16(c) Weld Check

Fillet weld: $t_{\min} = \min [19\text{mm}, t_n, t] = 3,35 \text{ mm}$

$$t_{c(\min)} = \min [6 \text{ mm}, 0,7 \cdot t_{\min}] = \underline{2,35} \text{ mm}$$

$$t_{c(\text{actual})} = 0,7 \cdot \text{Leg} = 0,7 \cdot 7,5 = 5,25 \text{ mm}$$

The fillet weld size is satisfactory.

Weld strength calculations are not required for this detail which conforms to Fig. UW-16.1, sketch (c-e).

UG-45 Nozzle Neck Thickness Check

Interpretation VIII-1-83-66 has been applied.

$$\begin{aligned} t_{aUG-27} &= \frac{P \cdot R_n}{S_n \cdot E - 0,6 \cdot P} + \text{Corrosion} \\ &= \frac{12,5 \cdot 13,35}{1.180 \cdot 1 - 0,6 \cdot 12,5} + 3 \\ &= 3,14 \text{ mm} \end{aligned}$$

$$\begin{aligned} t_a &= \max [t_{aUG-27}, t_{aUG-22}] \\ &= \max [3,14, 0] \\ &= 3,14 \text{ mm} \end{aligned}$$

$$\begin{aligned} t_{b1} &= \frac{P \cdot D_o \cdot K}{2 \cdot S \cdot E + 2 \cdot P \cdot (K - 0,1)} + \text{Corrosion} \\ &= \frac{12,5 \cdot 219,07 \cdot 0,963264}{2 \cdot 1.180 \cdot 1 + 2 \cdot 12,5 \cdot (0,963264 - 0,1)} + 3 \\ &= 4,11 \text{ mm} \end{aligned}$$

$$\begin{aligned} t_{b1} &= \max [t_{b1}, t_{bUG16}] \\ &= \max [4,11, 4,5] \\ &= 4,5 \text{ mm} \end{aligned}$$

$$\begin{aligned} t_b &= \min [t_{b3}, t_{b1}] \\ &= \min [5,96, 4,5] \\ &= 4,5 \text{ mm} \end{aligned}$$

$$\begin{aligned} t_{UG-45} &= \max [t_a, t_b] \\ &= \max [3,14, 4,5] \\ &= \underline{4,5} \text{ mm} \end{aligned}$$

Available nozzle wall thickness new, $t_n = 0,875 \cdot 6,35 = 5,56 \text{ mm}$

The nozzle neck thickness is adequate.

Reinforcement Calculations for MAWP

The thickness requirements of UG-45 govern the MAWP of this nozzle.

UG-37 Area Calculation Summary (cm ²)						UG-45 Summary (mm)		
For P = 29,2 bar @ 75 °C						The nozzle passes UG-45		
A required	A available	A ₁	A ₂	A ₃	A ₅	A welds	t _{req}	t _{min}
This nozzle is exempt from area calculations per UG-36(c)(3)(a)						5,56	5,56	

UG-41 Weld Failure Path Analysis Summary
The nozzle is exempt from weld strength calculations per UW-15(b)(2)

UW-16 Weld Sizing Summary			
Weld description	Required weld throat size (mm)	Actual weld throat size (mm)	Status
Nozzle to shell fillet (Leg ₄₁)	2,35	5,25	weld size is adequate

Calculations for internal pressure 29,2 bar @ 75 °C

Parallel Limit of reinforcement per UG-40

$$\begin{aligned}
 L_R &= \max [d, R_n + (t_n - C_n) + (t - C)] \\
 &= \max [26,7, 13,35 + (6,35 - 3) + (7,16 - 3)] \\
 &= 26,7 \text{ mm}
 \end{aligned}$$

Outer Normal Limit of reinforcement per UG-40

$$\begin{aligned}
 L_H &= \min [2,5 \cdot (t - C), 2,5 \cdot (t_n - C_n) + t_e] \\
 &= \min [2,5 \cdot (7,16 - 3), 2,5 \cdot (6,35 - 3) + 0] \\
 &= 8,38 \text{ mm}
 \end{aligned}$$

Nozzle required thickness per UG-27(c)(1)

$$\begin{aligned}
 t_{rn} &= \frac{P \cdot R_n}{S_n \cdot E - 0,6 \cdot P} \\
 &= \frac{29,2014 \cdot 13,35}{1,180 \cdot 1 - 0,6 \cdot 29,2014} \\
 &= 0,34 \text{ mm}
 \end{aligned}$$

Required thickness t_r from UG-37(a)(c)

$$\begin{aligned}
 t_r &= \frac{P \cdot K_1 \cdot D_o}{2 \cdot S \cdot E + 0,8 \cdot P} \\
 &= \frac{29,2014 \cdot 0,8749 \cdot 219,07}{2 \cdot 1,180 \cdot 1 + 0,8 \cdot 29,2014} \\
 &= 2,35 \text{ mm}
 \end{aligned}$$

Required thickness t_r per Interpretation VIII-1-07-50

$$t_r = \frac{P \cdot D_o \cdot K}{2 \cdot S \cdot E + 2 \cdot P \cdot (K - 0,1)} = \frac{29,2 \cdot 219,07 \cdot 0,963264}{2 \cdot 1,180 \cdot 0,85 + 2 \cdot 29,2 \cdot (0,963264 - 0,1)} = 3 \text{ mm}$$

This opening does not require reinforcement per UG-36(c)(3)(a)

UW-16(c) Weld Check

Fillet weld: $t_{\min} = \min [19\text{mm}, t_n, t] = 3,35 \text{ mm}$

$t_{c(\min)} = \min [6 \text{ mm}, 0,7 \cdot t_{\min}] = 2,35 \text{ mm}$

$t_{c(\text{actual})} = 0,7 \cdot \text{Leg} = 0,7 \cdot 7,5 = 5,25 \text{ mm}$

The fillet weld size is satisfactory.

Weld strength calculations are not required for this detail which conforms to Fig. UW-16.1, sketch (c-e).

UG-45 Nozzle Neck Thickness Check

Interpretation VIII-1-83-66 has been applied.

$$\begin{aligned} t_{aUG-27} &= \frac{P \cdot R_n}{S_n \cdot E - 0,6 \cdot P} + \text{Corrosion} \\ &= \frac{29,2014 \cdot 13,35}{1,180 \cdot 1 - 0,6 \cdot 29,2014} + 3 \\ &= 3,34 \text{ mm} \end{aligned}$$

$$\begin{aligned} t_a &= \max [t_{aUG-27}, t_{aUG-22}] \\ &= \max [3,34, 0] \\ &= 3,34 \text{ mm} \end{aligned}$$

$$\begin{aligned} t_{b1} &= \frac{P \cdot D_o \cdot K}{2 \cdot S \cdot E + 2 \cdot P \cdot (K - 0,1)} + \text{Corrosion} \\ &= \frac{29,2 \cdot 219,07 \cdot 0,963264}{2 \cdot 1,180 \cdot 1 + 2 \cdot 29,2 \cdot (0,963264 - 0,1)} + 3 \\ &= 5,56 \text{ mm} \end{aligned}$$

$$\begin{aligned} t_{b1} &= \max [t_{b1}, t_{bUG16}] \\ &= \max [5,56, 4,5] \\ &= 5,56 \text{ mm} \end{aligned}$$

$$\begin{aligned} t_b &= \min [t_{b3}, t_{b1}] \\ &= \min [5,96, 5,56] \\ &= 5,56 \text{ mm} \end{aligned}$$

$$\begin{aligned} t_{UG-45} &= \max [t_a, t_b] \\ &= \max [3,34, 5,56] \\ &= 5,56 \text{ mm} \end{aligned}$$

Available nozzle wall thickness new, $t_n = 0,875 \cdot 6,35 = 5,56 \text{ mm}$

The nozzle neck thickness is adequate.

Reinforcement Calculations for MAP

The vessel wall thickness governs the MAP of this nozzle.

UG-37 Area Calculation Summary (cm ²)							UG-45 Summary (mm)	
For P = 88,24 bar @ 21,11 °C							The nozzle passes UG-45	
A required	A available	A ₁	A ₂	A ₃	A ₅	A welds	t _{req}	t _{min}
This nozzle is exempt from area calculations per UG-36(c)(3)(a)							2,96	5,56

UG-41 Weld Failure Path Analysis Summary
The nozzle is exempt from weld strength calculations per UW-15(b)(2)

Calculations for internal pressure 88,24 bar @ 21,11 °C

Parallel Limit of reinforcement per UG-40

$$\begin{aligned}
 L_R &= \max [d, R_n + (t_n - C_n) + (t - C)] \\
 &= \max [20,7, 10,35 + (6,35 - 0) + (7,16 - 0)] \\
 &= 23,86 \text{ mm}
 \end{aligned}$$

Outer Normal Limit of reinforcement per UG-40

$$\begin{aligned}
 L_H &= \min [2,5 \cdot (t - C), 2,5 \cdot (t_n - C_n) + t_e] \\
 &= \min [2,5 \cdot (7,16 - 0), 2,5 \cdot (6,35 - 0) + 0] \\
 &= 15,88 \text{ mm}
 \end{aligned}$$

Nozzle required thickness per UG-27(c)(1)

$$\begin{aligned}
 t_{rn} &= \frac{P \cdot R_n}{S_n \cdot E - 0,6 \cdot P} \\
 &= \frac{88,237 \cdot 10,35}{1.180 \cdot 1 - 0,6 \cdot 88,237} \\
 &= 0,81 \text{ mm}
 \end{aligned}$$

Required thickness t_r from UG-37(a)(c)

$$\begin{aligned}
 t_r &= \frac{P \cdot K_1 \cdot D_o}{2 \cdot S \cdot E + 0,8 \cdot P} \\
 &= \frac{88,237 \cdot 0,9 \cdot 219,07}{2 \cdot 1.180 \cdot 1 + 0,8 \cdot 88,237} \\
 &= 7,16 \text{ mm}
 \end{aligned}$$

Required thickness t_r per Interpretation VIII-1-07-50

$$t_r = \frac{P \cdot D_o \cdot K}{2 \cdot S \cdot E + 2 \cdot P \cdot (K - 0,1)} = \frac{88,24 \cdot 219,07 \cdot 1}{2 \cdot 1.180 \cdot 0,85 + 2 \cdot 88,24 \cdot (1 - 0,1)} = 8,93 \text{ mm}$$

This opening does not require reinforcement per UG-36(c)(3)(a)

UG-45 Nozzle Neck Thickness Check

Interpretation VIII-1-83-66 has been applied.

$$\begin{aligned}t_{aUG-27} &= \frac{P \cdot R_n}{S_n \cdot E - 0,6 \cdot P} + \text{Corrosion} \\ &= \frac{88,237 \cdot 10,35}{1.180 \cdot 1 - 0,6 \cdot 88,237} + 0 \\ &= 0,81 \text{ mm}\end{aligned}$$

$$\begin{aligned}t_a &= \max [t_{aUG-27}, t_{aUG-22}] \\ &= \max [0,81, 0] \\ &= 0,81 \text{ mm}\end{aligned}$$

$$\begin{aligned}t_{b1} &= \frac{P \cdot D_o \cdot K}{2 \cdot S \cdot E + 2 \cdot P \cdot (K - 0,1)} + \text{Corrosion} \\ &= \frac{88,24 \cdot 219,07 \cdot 1}{2 \cdot 1.180 \cdot 1 + 2 \cdot 88,24 \cdot (1 - 0,1)} + 0 \\ &= 7,67 \text{ mm}\end{aligned}$$

$$\begin{aligned}t_{b1} &= \max [t_{b1}, t_{bUG16}] \\ &= \max [7,67, 1,5] \\ &= 7,67 \text{ mm}\end{aligned}$$

$$\begin{aligned}t_b &= \min [t_{b3}, t_{b1}] \\ &= \min [2,96, 7,67] \\ &= 2,96 \text{ mm}\end{aligned}$$

$$\begin{aligned}t_{UG-45} &= \max [t_a, t_b] \\ &= \max [0,81, 2,96] \\ &= \underline{2.96} \text{ mm}\end{aligned}$$

Available nozzle wall thickness new, $t_n = 0,875 \cdot 6,35 = 5,56 \text{ mm}$

The nozzle neck thickness is adequate.

B16.9 Elbow #1 (N1)

ASME Section VIII Division 1, 2021 Edition Metric				
Component		ASME B16.9 Elbow		
Type		Long Radius 90-deg		
Material		SA-234 WPB (II-D Metric p. 16, In. 18)		
Pipe NPS and Schedule		NPS 1 Sch 160 DN 25		
Attached To		Air Inlet (N1)		
Impact Tested	Normalized	Fine Grain Practice	PWHT	Maximize MDMT/ No MAWP
No	No	No	No	No
		Design Pressure (bar)	Design Temperature (°C)	Design MDMT (°C)
Internal		12,5	75	0
Static Liquid Head				
Condition		P_s (bar)	H_s (mm)	SG
Test horizontal		0,03	288,1	1
Dimensions				
Outer Diameter		33,4 mm		
Nominal Thickness		6,35 mm		
Minimum Thickness¹		5,56 mm		
Center-to-End, A		38 mm		
Corrosion	Inner	3 mm		
	Outer	0 mm		
Weight and Capacity				
		Weight (kg)	Capacity (liters)	
New		0,25	0,02	
Corroded		0,15	0,03	
Radiography				
Longitudinal seam		Seamless No RT		
Left Circumferential seam		Full UW-11(a) Type 1		
Right Circumferential seam		Full UW-11(a) Type 1		

¹ minimum thickness = nominal thickness times pipe tolerance factor of 0,875.

ASME B16.5-2017 Flange	
Description	NPS 1 Class 150 WN A105
Bolt Material	SA-193 B7 Bolt <= 64 (II-D Metric p. 410, ln. 32)
Blind included	No
Rated MDMT	-29°C
Liquid static head	0 bar
MAWP rating	18,45 bar @ 75°C
MAP rating	19,6 bar @ 21,11°C
Hydrotest rating	30 bar @ 21,11°C
PWHT performed	No
Produced to Fine Grain Practice and Supplied in Heat Treated Condition	No
Impact Tested	No
Circumferential joint radiography	Full UW-11(a) Type 1
Gasket	
Type	ASME B16.21 Nonmetallic Flat Gasket
Description	Flexitallic Compressed Fiber SF 2401 Synthetic/NBR
Factor, m	3,2
Seating Stress, y	203,89 kg _f /cm ²
Thickness, T	3 mm
Inner Diameter	33 mm
Outer Diameter	67 mm
Notes	
Flange rated MDMT per UG-20(f) = -29°C Bolts rated MDMT per Fig UCS-66 note (c) = -48°C	

Results Summary	
Governing condition	UG-16
Minimum thickness per UG-16	1,5 mm + 3 mm = 4,5 mm
Design thickness due to internal pressure (t)	3.18 mm
Maximum allowable working pressure (MAWP)	192.42 bar
Maximum allowable pressure (MAP)	477.33 bar
Rated MDMT	-105 °C

UCS-66 Material Toughness Requirements	
$t_r = \frac{27,8 \cdot 16,7}{1.180 \cdot 1 + 0,4 \cdot 27,8} =$	0,39 mm
Stress ratio = $\frac{t_r \cdot E^*}{t_n - c} = \frac{0,39 \cdot 1}{5,56 - 3} =$	0,1525
Stress ratio ≤ 0,35, MDMT per UCS-66(b)(3) =	-105°C
Material is exempt from impact testing at the Design MDMT of 0°C.	

Design thickness, (at 75 °C) Appendix 1-1

$$t = \frac{P \cdot R_o}{S \cdot E + 0,40 \cdot P} + \text{Corrosion} = \frac{12,5 \cdot 16,7}{1.180 \cdot 1,00 + 0,40 \cdot 12,5} + 3 = \underline{3.18} \text{ mm}$$

Maximum allowable working pressure, (at 75 °C) Appendix 1-1

$$P = \frac{S \cdot E \cdot t}{R_o - 0,40 \cdot t} - P_s = \frac{1.180 \cdot 1,00 \cdot (6,35 \cdot 0,875 - 3)}{16,7 - 0,40 \cdot (6,35 \cdot 0,875 - 3)} - 0 = \underline{192.42} \text{ bar}$$

Maximum allowable pressure, (at 21,11 °C) Appendix 1-2

$$P = S \cdot E \cdot \ln\left(\frac{R_o}{R_o - t}\right) = 1.180 \cdot 1,00 \cdot \ln\left(\frac{16,7}{16,7 - (6,35 \cdot 0,875)}\right) = \underline{477,33} \text{ bar}$$

Cylinder #1

ASME Section VIII Division 1, 2021 Edition Metric				
Component		Cylinder		
Material		SA-106 B Smls Pipe (II-D Metric p. 16, ln. 16)		
Pipe NPS and Schedule		NPS 8 Sch 40 (Std) DN 200		
Impact Tested	Normalized	Fine Grain Practice	PWHT	Maximize MDMT/ No MAWP
No	No	No	No	No
		Design Pressure (bar)	Design Temperature (°C)	Design MDMT (°C)
Internal		12,5	75	0
Static Liquid Head				
Condition	P_s (bar)	H_s (mm)	SG	
Test horizontal	0,03	351,36	1	
Dimensions				
Outer Diameter		219,07 mm		
Length		1.060 mm		
Pipe Nominal Thickness		8,18 mm		
Pipe Minimum Thickness¹		7,16 mm		
Corrosion	Inner	3 mm		
	Outer	0 mm		
Weight and Capacity				
		Weight (kg)	Capacity (liters)	
New		44,63	34,21	
Corroded		28,67	36,26	
Radiography				
Longitudinal seam		Seamless No RT		
Left Circumferential seam		Spot UW-11(b) Type 1		
Right Circumferential seam		Spot UW-11(b) Type 1		

¹Pipe minimum thickness = nominal thickness times pipe tolerance factor of 0,875.

Results Summary	
Governing condition	UG-16
Minimum thickness per UG-16	1,5 mm + 3 mm = 4,5 mm
Design thickness due to internal pressure (t)	4.36 mm
Maximum allowable working pressure (MAWP)	38.66 bar
Maximum allowable pressure (MAP)	67.3 bar
Rated MDMT	-48 °C

UCS-66 Material Toughness Requirements	
Governing thickness, t _g =	7,16 mm
Exemption temperature from Fig UCS-66M Curve B =	-29°C
$t_r = \frac{18,45 \cdot 109,54}{1.180 \cdot 0,85 + 0,4 \cdot 18,45} =$	2 mm
$\text{Stress ratio} = \frac{t_r \cdot E^*}{t_n - c} = \frac{2 \cdot 0,85}{7,16 - 3} =$	0,4089
Reduction in MDMT, T _R from Fig UCS-66.1M =	48,8°C
$MDMT = \max [MDMT - T_R, -48] = \max [-29 - 48,8, -48] =$	-48°C
Material is exempt from impact testing at the Design MDMT of 0°C.	

Design thickness, (at 75 °C) Appendix 1-1

$$t = \frac{P \cdot R_o}{S \cdot E + 0,40 \cdot P} + \text{Corrosion} = \frac{12,5 \cdot 109,54}{1.180 \cdot 0,85 + 0,40 \cdot 12,5} + 3 = 4,36 \text{ mm}$$

Maximum allowable working pressure, (at 75 °C) Appendix 1-1

$$P = \frac{S \cdot E \cdot t}{R_o - 0,40 \cdot t} - P_s = \frac{1.180 \cdot 0,85 \cdot (8,18 \cdot 0,875 - 3)}{109,54 - 0,40 \cdot (8,18 \cdot 0,875 - 3)} - 0 = 38,66 \text{ bar}$$

Maximum allowable pressure, (at 21,11 °C) Appendix 1-1

$$P = \frac{S \cdot E \cdot t}{R_o - 0,40 \cdot t} = \frac{1.180 \cdot 0,85 \cdot (8,18 \cdot 0,875)}{109,54 - 0,40 \cdot (8,18 \cdot 0,875)} = 67,3 \text{ bar}$$

Temperature Gauge Connection (N3)

ASME Section VIII Division 1, 2021 Edition Metric

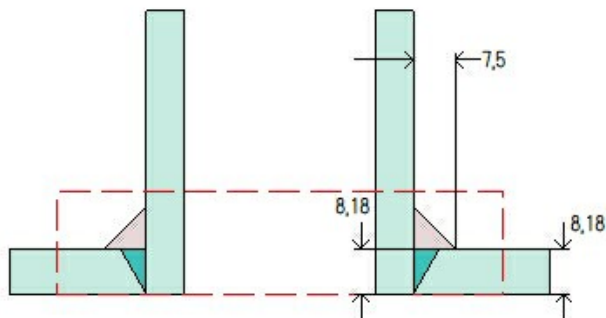

Note: round inside edges per UG-76(c)

Location and Orientation

Located on	Cylinder #1
Orientation	0°
Nozzle center line offset to datum line	720 mm
End of nozzle to shell center	250 mm
Passes through a Category A joint	No

Nozzle

Description	NPS 1,5 Sch 160 DN 40
Access opening	No
Material specification	SA-106 B Smls Pipe (II-D Metric p. 16, In. 16)
Inside diameter, new	33,99 mm
Pipe nominal wall thickness	7,14 mm
Pipe minimum wall thickness ¹	6,25 mm
Corrosion allowance	3 mm
Projection available outside vessel, Lpr	72,14 mm
Projection available outside vessel to flange face, Lf	140,47 mm
Local vessel minimum thickness	7,16 mm
Liquid static head included	0 bar

Welds

Inner fillet, Leg ₄₁	7,5 mm
Nozzle to vessel groove weld	8,18 mm

Radiography

Longitudinal seam	Seamless No RT
Circumferential seam	Full UW-11(a) Type 1

¹Pipe minimum thickness = nominal thickness times pipe tolerance factor of 0,875.

ASME B16.5-2017 Flange	
Description	NPS 1,5 Class 300 WN A105
Bolt Material	SA-193 B7 Bolt <= 64 (II-D Metric p. 410, ln. 32)
Blind included	No
Rated MDMT	-48°C
Liquid static head	0 bar
MAWP rating	48,35 bar @ 75°C
MAP rating	51,1 bar @ 21,11°C
Hydrotest rating	77 bar @ 21,11°C
PWHT performed	No
Produced to Fine Grain Practice and Supplied in Heat Treated Condition	No
Impact Tested	No
Circumferential joint radiography	Full UW-11(a) Type 1
Gasket	
Type	ASME B16.20 Spiral-Wound
Description	Garlock FLEXSEAL RW 316L SS / Flexible Graphite
Factor, m	3
Seating Stress, y	703,07 kg/cm ²
Thickness, T	3 mm
Inner Diameter	54,1 mm
Outer Diameter	69,9 mm
Notes	
Flange rated MDMT per UCS-66(b)(1)(b) = -48°C (Coincident ratio = 0,3611) Bolts rated MDMT per Fig UCS-66 note (c) = -48°C	

UCS-66 Material Toughness Requirements Nozzle	
$t_r = \frac{18,45 \cdot 19,99}{1,180 \cdot 1 - 0,6 \cdot 18,45} =$	0,32 mm
Stress ratio = $\frac{t_r \cdot E^*}{t_n - c} = \frac{0,32 \cdot 1}{6,25 - 3} =$	0,0972
Stress ratio ≤ 0,35, MDMT per UCS-66(b)(3) =	-105°C
Material is exempt from impact testing at the Design MDMT of 0°C.	

Reinforcement Calculations for Internal Pressure

UG-37 Area Calculation Summary (cm ²)							UG-45 Summary (mm)	
For P = 12,5 bar @ 75 °C							The nozzle passes UG-45	
A required	A available	A ₁	A ₂	A ₃	A ₅	A welds	t _{req}	t _{min}
This nozzle is exempt from area calculations per UG-36(c)(3)(a)							4,5	6,25

UG-41 Weld Failure Path Analysis Summary
The nozzle is exempt from weld strength calculations per UW-15(b)(2)

UW-16 Weld Sizing Summary			
Weld description	Required weld throat size (mm)	Actual weld throat size (mm)	Status
Nozzle to shell fillet (Leg ₄₁)	2,9	5,25	weld size is adequate

Calculations for internal pressure 12,5 bar @ 75 °C

Parallel Limit of reinforcement per UG-40

$$\begin{aligned}
 L_R &= \max [d, R_n + (t_n - C_n) + (t - C)] \\
 &= \max [39,99, 19,99 + (7,14 - 3) + (7,16 - 3)] \\
 &= 39,99 \text{ mm}
 \end{aligned}$$

Outer Normal Limit of reinforcement per UG-40

$$\begin{aligned}
 L_H &= \min [2,5 \cdot (t - C), 2,5 \cdot (t_n - C_n) + t_e] \\
 &= \min [2,5 \cdot (7,16 - 3), 2,5 \cdot (7,14 - 3) + 0] \\
 &= 10,34 \text{ mm}
 \end{aligned}$$

Nozzle required thickness per UG-27(c)(1)

$$\begin{aligned}
 t_{rn} &= \frac{P \cdot R_n}{S_n \cdot E - 0,6 \cdot P} \\
 &= \frac{12,5 \cdot 19,99}{1.180 \cdot 1 - 0,6 \cdot 12,5} \\
 &= 0,21 \text{ mm}
 \end{aligned}$$

Required thickness t_r from UG-37(a)

$$\begin{aligned}
 t_r &= \frac{P \cdot R_o}{S \cdot E + 0,4 \cdot P} \\
 &= \frac{12,5 \cdot 109,54}{1.180 \cdot 1 + 0,4 \cdot 12,5} \\
 &= 1,16 \text{ mm}
 \end{aligned}$$

Required thickness t_r per Interpretation VIII-1-07-50

$$\begin{aligned}
t_r &= \frac{P \cdot R_o}{S \cdot E + 0,4 \cdot P} \\
&= \frac{12,5 \cdot 109,54}{1.180 \cdot 0,85 + 0,4 \cdot 12,5} \\
&= 1,36 \text{ mm}
\end{aligned}$$

This opening does not require reinforcement per UG-36(c)(3)(a)

UW-16(c) Weld Check

Fillet weld: $t_{\min} = \min [19\text{mm}, t_n, t] = 4,14 \text{ mm}$

$$t_{c(\min)} = \min [6 \text{ mm}, 0,7 \cdot t_{\min}] = \underline{2,9} \text{ mm}$$

$$t_{c(\text{actual})} = 0,7 \cdot \text{Leg} = 0,7 \cdot 7,5 = 5,25 \text{ mm}$$

The fillet weld size is satisfactory.

Weld strength calculations are not required for this detail which conforms to Fig. UW-16.1, sketch (c-e).

UG-45 Nozzle Neck Thickness Check

$$\begin{aligned}
t_{aUG-27} &= \frac{P \cdot R_n}{S_n \cdot E - 0,6 \cdot P} + \text{Corrosion} \\
&= \frac{12,5 \cdot 19,99}{1.180 \cdot 1 - 0,6 \cdot 12,5} + 3 \\
&= 3,21 \text{ mm}
\end{aligned}$$

$$\begin{aligned}
t_a &= \max [t_{aUG-27}, t_{aUG-22}] \\
&= \max [3,21, 0] \\
&= 3,21 \text{ mm}
\end{aligned}$$

$$\begin{aligned}
t_{b1} &= \frac{P \cdot R_o}{S \cdot E + 0,4 \cdot P} + \text{Corrosion} \\
&= \frac{12,5 \cdot 109,54}{1.180 \cdot 1 + 0,4 \cdot 12,5} + 3 \\
&= 4,16 \text{ mm}
\end{aligned}$$

$$\begin{aligned}
t_{b1} &= \max [t_{b1}, t_{bUG16}] \\
&= \max [4,16, 4,5] \\
&= 4,5 \text{ mm}
\end{aligned}$$

$$\begin{aligned}
t_b &= \min [t_{b3}, t_{b1}] \\
&= \min [6,22, 4,5] \\
&= 4,5 \text{ mm}
\end{aligned}$$

$$\begin{aligned}
t_{UG-45} &= \max [t_a, t_b] \\
&= \max [3,21, 4,5] \\
&= \underline{4,5} \text{ mm}
\end{aligned}$$

Available nozzle wall thickness new, $t_n = 0,875 \cdot 7,14 = 6,25$ mm

The nozzle neck thickness is adequate.

Reinforcement Calculations for MAWP

The vessel wall thickness governs the MAWP of this nozzle.

UG-37 Area Calculation Summary (cm ²)							UG-45 Summary (mm)	
For P = 45,49 bar @ 75 °C							The nozzle passes UG-45	
A required	A available	A ₁	A ₂	A ₃	A ₅	A welds	t _{req}	t _{min}
This nozzle is exempt from area calculations per UG-36(c)(3)(a)							6,22	6,25

UG-41 Weld Failure Path Analysis Summary
The nozzle is exempt from weld strength calculations per UW-15(b)(2)

UW-16 Weld Sizing Summary			
Weld description	Required weld throat size (mm)	Actual weld throat size (mm)	Status
Nozzle to shell fillet (Leg ₄₁)	2,9	5,25	weld size is adequate

Calculations for internal pressure 45,49 bar @ 75 °C

Parallel Limit of reinforcement per UG-40

$$\begin{aligned}
 L_R &= \max [d, R_n + (t_n - C_n) + (t - C)] \\
 &= \max [39,99, 19,99 + (7,14 - 3) + (7,16 - 3)] \\
 &= 39,99 \text{ mm}
 \end{aligned}$$

Outer Normal Limit of reinforcement per UG-40

$$\begin{aligned}
 L_H &= \min [2,5 \cdot (t - C), 2,5 \cdot (t_n - C_n) + t_e] \\
 &= \min [2,5 \cdot (7,16 - 3), 2,5 \cdot (7,14 - 3) + 0] \\
 &= 10,34 \text{ mm}
 \end{aligned}$$

Nozzle required thickness per UG-27(c)(1)

$$\begin{aligned}
 t_{rn} &= \frac{P \cdot R_n}{S_n \cdot E - 0,6 \cdot P} \\
 &= \frac{45,4851 \cdot 19,99}{1,180 \cdot 1 - 0,6 \cdot 45,4851} \\
 &= 0,79 \text{ mm}
 \end{aligned}$$

Required thickness t_r from UG-37(a)

$$\begin{aligned}
 t_r &= \frac{P \cdot R_o}{S \cdot E + 0,4 \cdot P} \\
 &= \frac{45,4851 \cdot 109,54}{1,180 \cdot 1 + 0,4 \cdot 45,4851} \\
 &= 4,16 \text{ mm}
 \end{aligned}$$

Required thickness t_r per Interpretation VIII-1-07-50

$$\begin{aligned}
t_r &= \frac{P \cdot R_o}{S \cdot E + 0,4 \cdot P} \\
&= \frac{45,4851 \cdot 109,54}{1.180 \cdot 0,85 + 0,4 \cdot 45,4851} \\
&= 4,88 \text{ mm}
\end{aligned}$$

This opening does not require reinforcement per UG-36(c)(3)(a)

UW-16(c) Weld Check

Fillet weld: $t_{\min} = \min [19\text{mm}, t_n, t] = 4,14 \text{ mm}$

$t_{c(\min)} = \min [6 \text{ mm}, 0,7 \cdot t_{\min}] = 2,9 \text{ mm}$

$t_{c(\text{actual})} = 0,7 \cdot \text{Leg} = 0,7 \cdot 7,5 = 5,25 \text{ mm}$

The fillet weld size is satisfactory.

Weld strength calculations are not required for this detail which conforms to Fig. UW-16.1, sketch (c-e).

UG-45 Nozzle Neck Thickness Check

$$\begin{aligned}
t_{aUG-27} &= \frac{P \cdot R_n}{S_n \cdot E - 0,6 \cdot P} + \text{Corrosion} \\
&= \frac{45,4851 \cdot 19,99}{1.180 \cdot 1 - 0,6 \cdot 45,4851} + 3 \\
&= 3,79 \text{ mm}
\end{aligned}$$

$$\begin{aligned}
t_a &= \max [t_{aUG-27}, t_{aUG-22}] \\
&= \max [3,79, 0] \\
&= 3,79 \text{ mm}
\end{aligned}$$

$$\begin{aligned}
t_{b1} &= \frac{P \cdot R_o}{S \cdot E + 0,4 \cdot P} + \text{Corrosion} \\
&= \frac{45,4851 \cdot 109,54}{1.180 \cdot 1 + 0,4 \cdot 45,4851} + 3 \\
&= 7,16 \text{ mm}
\end{aligned}$$

$$\begin{aligned}
t_{b1} &= \max [t_{b1}, t_{bUG16}] \\
&= \max [7,16, 4,5] \\
&= 7,16 \text{ mm}
\end{aligned}$$

$$\begin{aligned}
t_b &= \min [t_{b3}, t_{b1}] \\
&= \min [6,22, 7,16] \\
&= 6,22 \text{ mm}
\end{aligned}$$

$$\begin{aligned}
t_{UG-45} &= \max [t_a, t_b] \\
&= \max [3,79, 6,22] \\
&= 6,22 \text{ mm}
\end{aligned}$$

Available nozzle wall thickness new, $t_n = 0,875 \cdot 7,14 = 6,25$ mm

The nozzle neck thickness is adequate.

Reinforcement Calculations for MAP

The attached ASME B16.5 flange limits the nozzle MAP.

UG-37 Area Calculation Summary (cm ²)							UG-45 Summary (mm)	
For P = 51,1 bar @ 21,11 °C							The nozzle passes UG-45	
A required	A available	A ₁	A ₂	A ₃	A ₅	A welds	t _{req}	t _{min}
This nozzle is exempt from area calculations per UG-36(c)(3)(a)							3,22	6,25

UG-41 Weld Failure Path Analysis Summary
The nozzle is exempt from weld strength calculations per UW-15(b)(2)

Calculations for internal pressure 51,1 bar @ 21,11 °C

Parallel Limit of reinforcement per UG-40

$$\begin{aligned}
 L_R &= \max [d, R_n + (t_n - C_n) + (t - C)] \\
 &= \max [33,99, 16,99 + (7,14 - 0) + (7,16 - 0)] \\
 &= 33,99 \text{ mm}
 \end{aligned}$$

Outer Normal Limit of reinforcement per UG-40

$$\begin{aligned}
 L_H &= \min [2,5 \cdot (t - C), 2,5 \cdot (t_n - C_n) + t_e] \\
 &= \min [2,5 \cdot (7,16 - 0), 2,5 \cdot (7,14 - 0) + 0] \\
 &= 17,84 \text{ mm}
 \end{aligned}$$

Nozzle required thickness per UG-27(c)(1)

$$\begin{aligned}
 t_{rn} &= \frac{P \cdot R_n}{S_n \cdot E - 0,6 \cdot P} \\
 &= \frac{51,1 \cdot 16,99}{1.180 \cdot 1 - 0,6 \cdot 51,1} \\
 &= 0,75 \text{ mm}
 \end{aligned}$$

Required thickness t_r from UG-37(a)

$$\begin{aligned}
 t_r &= \frac{P \cdot R_o}{S \cdot E + 0,4 \cdot P} \\
 &= \frac{51,1 \cdot 109,54}{1.180 \cdot 1 + 0,4 \cdot 51,1} \\
 &= 4,66 \text{ mm}
 \end{aligned}$$

Required thickness t_r per Interpretation VIII-1-07-50

$$\begin{aligned}
 t_r &= \frac{P \cdot R_o}{S \cdot E + 0,4 \cdot P} \\
 &= \frac{51,1 \cdot 109,54}{1.180 \cdot 0,85 + 0,4 \cdot 51,1} \\
 &= 5,47 \text{ mm}
 \end{aligned}$$

This opening does not require reinforcement per UG-36(c)(3)(a)

UG-45 Nozzle Neck Thickness Check

$$\begin{aligned}t_{aUG-27} &= \frac{P \cdot R_n}{S_n \cdot E - 0,6 \cdot P} + \text{Corrosion} \\ &= \frac{51,1 \cdot 16,99}{1.180 \cdot 1 - 0,6 \cdot 51,1} + 0 \\ &= 0,75 \text{ mm}\end{aligned}$$

$$\begin{aligned}t_a &= \max [t_{aUG-27}, t_{aUG-22}] \\ &= \max [0,75, 0] \\ &= 0,75 \text{ mm}\end{aligned}$$

$$\begin{aligned}t_{b1} &= \frac{P \cdot R_o}{S \cdot E + 0,4 \cdot P} + \text{Corrosion} \\ &= \frac{51,1 \cdot 109,54}{1.180 \cdot 1 + 0,4 \cdot 51,1} + 0 \\ &= 4,66 \text{ mm}\end{aligned}$$

$$\begin{aligned}t_{b1} &= \max [t_{b1}, t_{bUG16}] \\ &= \max [4,66, 1,5] \\ &= 4,66 \text{ mm}\end{aligned}$$

$$\begin{aligned}t_b &= \min [t_{b3}, t_{b1}] \\ &= \min [3,22, 4,66] \\ &= 3,22 \text{ mm}\end{aligned}$$

$$\begin{aligned}t_{UG-45} &= \max [t_a, t_b] \\ &= \max [0,75, 3,22] \\ &= \underline{3,22} \text{ mm}\end{aligned}$$

Available nozzle wall thickness new, $t_n = 0,875 \cdot 7,14 = 6,25 \text{ mm}$

The nozzle neck thickness is adequate.

Temperature Transmitter Connection (N4)

ASME Section VIII Division 1, 2021 Edition Metric

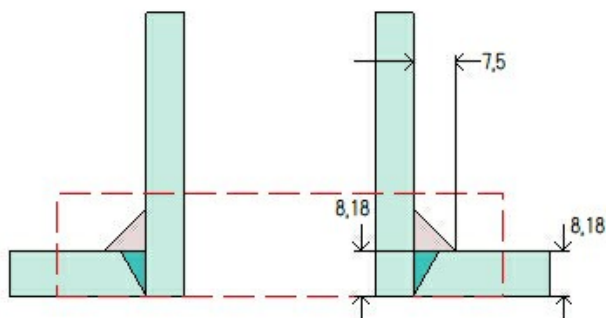

Note: round inside edges per UG-76(c)

Location and Orientation

Located on	Cylinder #1
Orientation	0°
Nozzle center line offset to datum line	505 mm
End of nozzle to shell center	250 mm
Passes through a Category A joint	No

Nozzle

Description	NPS 1,5 Sch 160 DN 40
Access opening	No
Material specification	SA-106 B Smls Pipe (II-D Metric p. 16, In. 16)
Inside diameter, new	33,99 mm
Pipe nominal wall thickness	7,14 mm
Pipe minimum wall thickness ¹	6,25 mm
Corrosion allowance	3 mm
Projection available outside vessel, Lpr	72,14 mm
Projection available outside vessel to flange face, Lf	140,47 mm
Local vessel minimum thickness	7,16 mm
Liquid static head included	0 bar

Welds

Inner fillet, Leg ₄₁	7,5 mm
Nozzle to vessel groove weld	8,18 mm

Radiography

Longitudinal seam	Seamless No RT
Circumferential seam	Full UW-11(a) Type 1

¹Pipe minimum thickness = nominal thickness times pipe tolerance factor of 0,875.

ASME B16.5-2017 Flange	
Description	NPS 1,5 Class 300 WN A105
Bolt Material	SA-193 B7 Bolt <= 64 (II-D Metric p. 410, ln. 32)
Blind included	No
Rated MDMT	-48°C
Liquid static head	0 bar
MAWP rating	48,35 bar @ 75°C
MAP rating	51,1 bar @ 21,11°C
Hydrotest rating	77 bar @ 21,11°C
PWHT performed	No
Produced to Fine Grain Practice and Supplied in Heat Treated Condition	No
Impact Tested	No
Circumferential joint radiography	Full UW-11(a) Type 1
Gasket	
Type	ASME B16.20 Spiral-Wound
Description	Garlock FLEXSEAL RW 316L SS / Flexible Graphite
Factor, m	3
Seating Stress, y	703,07 kg/cm ²
Thickness, T	3 mm
Inner Diameter	54,1 mm
Outer Diameter	69,9 mm
Notes	
Flange rated MDMT per UCS-66(b)(1)(b) = -48°C (Coincident ratio = 0,3611) Bolts rated MDMT per Fig UCS-66 note (c) = -48°C	

UCS-66 Material Toughness Requirements Nozzle	
$t_r = \frac{18,45 \cdot 19,99}{1,180 \cdot 1 - 0,6 \cdot 18,45} =$	0,32 mm
Stress ratio = $\frac{t_r \cdot E^*}{t_n - c} = \frac{0,32 \cdot 1}{6,25 - 3} =$	0,0972
Stress ratio ≤ 0,35, MDMT per UCS-66(b)(3) =	-105°C
Material is exempt from impact testing at the Design MDMT of 0°C.	

Reinforcement Calculations for Internal Pressure

UG-37 Area Calculation Summary (cm ²)							UG-45 Summary (mm)	
For P = 12,5 bar @ 75 °C							The nozzle passes UG-45	
A required	A available	A ₁	A ₂	A ₃	A ₅	A welds	t _{req}	t _{min}
This nozzle is exempt from area calculations per UG-36(c)(3)(a)							4,5	6,25

UG-41 Weld Failure Path Analysis Summary
The nozzle is exempt from weld strength calculations per UW-15(b)(2)

UW-16 Weld Sizing Summary			
Weld description	Required weld throat size (mm)	Actual weld throat size (mm)	Status
Nozzle to shell fillet (Leg ₄₁)	2,9	5,25	weld size is adequate

Calculations for internal pressure 12,5 bar @ 75 °C

Parallel Limit of reinforcement per UG-40

$$\begin{aligned}
 L_R &= \max [d, R_n + (t_n - C_n) + (t - C)] \\
 &= \max [39,99, 19,99 + (7,14 - 3) + (7,16 - 3)] \\
 &= 39,99 \text{ mm}
 \end{aligned}$$

Outer Normal Limit of reinforcement per UG-40

$$\begin{aligned}
 L_H &= \min [2,5 \cdot (t - C), 2,5 \cdot (t_n - C_n) + t_e] \\
 &= \min [2,5 \cdot (7,16 - 3), 2,5 \cdot (7,14 - 3) + 0] \\
 &= 10,34 \text{ mm}
 \end{aligned}$$

Nozzle required thickness per UG-27(c)(1)

$$\begin{aligned}
 t_{rn} &= \frac{P \cdot R_n}{S_n \cdot E - 0,6 \cdot P} \\
 &= \frac{12,5 \cdot 19,99}{1.180 \cdot 1 - 0,6 \cdot 12,5} \\
 &= 0,21 \text{ mm}
 \end{aligned}$$

Required thickness t_r from UG-37(a)

$$\begin{aligned}
 t_r &= \frac{P \cdot R_o}{S \cdot E + 0,4 \cdot P} \\
 &= \frac{12,5 \cdot 109,54}{1.180 \cdot 1 + 0,4 \cdot 12,5} \\
 &= 1,16 \text{ mm}
 \end{aligned}$$

Required thickness t_r per Interpretation VIII-1-07-50

$$\begin{aligned}
 t_r &= \frac{P \cdot R_o}{S \cdot E + 0,4 \cdot P} \\
 &= \frac{12,5 \cdot 109,54}{1.180 \cdot 0,85 + 0,4 \cdot 12,5} \\
 &= 1,36 \text{ mm}
 \end{aligned}$$

This opening does not require reinforcement per UG-36(c)(3)(a)

UW-16(c) Weld Check

Fillet weld: $t_{\min} = \min [19\text{mm}, t_n, t] = 4,14 \text{ mm}$

$$t_{c(\min)} = \min [6 \text{ mm}, 0,7 \cdot t_{\min}] = \underline{2,9} \text{ mm}$$

$$t_{c(\text{actual})} = 0,7 \cdot \text{Leg} = 0,7 \cdot 7,5 = 5,25 \text{ mm}$$

The fillet weld size is satisfactory.

Weld strength calculations are not required for this detail which conforms to Fig. UW-16.1, sketch (c-e).

UG-45 Nozzle Neck Thickness Check

$$\begin{aligned}
 t_{aUG-27} &= \frac{P \cdot R_n}{S_n \cdot E - 0,6 \cdot P} + \text{Corrosion} \\
 &= \frac{12,5 \cdot 19,99}{1.180 \cdot 1 - 0,6 \cdot 12,5} + 3 \\
 &= 3,21 \text{ mm}
 \end{aligned}$$

$$\begin{aligned}
 t_a &= \max [t_{aUG-27}, t_{aUG-22}] \\
 &= \max [3,21, 0] \\
 &= 3,21 \text{ mm}
 \end{aligned}$$

$$\begin{aligned}
 t_{b1} &= \frac{P \cdot R_o}{S \cdot E + 0,4 \cdot P} + \text{Corrosion} \\
 &= \frac{12,5 \cdot 109,54}{1.180 \cdot 1 + 0,4 \cdot 12,5} + 3 \\
 &= 4,16 \text{ mm}
 \end{aligned}$$

$$\begin{aligned}
 t_{b1} &= \max [t_{b1}, t_{bUG16}] \\
 &= \max [4,16, 4,5] \\
 &= 4,5 \text{ mm}
 \end{aligned}$$

$$\begin{aligned}
 t_b &= \min [t_{b3}, t_{b1}] \\
 &= \min [6,22, 4,5] \\
 &= 4,5 \text{ mm}
 \end{aligned}$$

$$\begin{aligned}
 t_{UG-45} &= \max [t_a, t_b] \\
 &= \max [3,21, 4,5] \\
 &= \underline{4,5} \text{ mm}
 \end{aligned}$$

Available nozzle wall thickness new, $t_n = 0,875 \cdot 7,14 = 6,25$ mm

The nozzle neck thickness is adequate.

Reinforcement Calculations for MAWP

The vessel wall thickness governs the MAWP of this nozzle.

UG-37 Area Calculation Summary (cm ²)							UG-45 Summary (mm)	
For P = 45,49 bar @ 75 °C							The nozzle passes UG-45	
A required	A available	A ₁	A ₂	A ₃	A ₅	A welds	t _{req}	t _{min}
This nozzle is exempt from area calculations per UG-36(c)(3)(a)							6,22	6,25

UG-41 Weld Failure Path Analysis Summary
The nozzle is exempt from weld strength calculations per UW-15(b)(2)

UW-16 Weld Sizing Summary			
Weld description	Required weld throat size (mm)	Actual weld throat size (mm)	Status
Nozzle to shell fillet (Leg ₄₁)	2,9	5,25	weld size is adequate

Calculations for internal pressure 45,49 bar @ 75 °C

Parallel Limit of reinforcement per UG-40

$$\begin{aligned}
 L_R &= \max [d, R_n + (t_n - C_n) + (t - C)] \\
 &= \max [39,99, 19,99 + (7,14 - 3) + (7,16 - 3)] \\
 &= 39,99 \text{ mm}
 \end{aligned}$$

Outer Normal Limit of reinforcement per UG-40

$$\begin{aligned}
 L_H &= \min [2,5 \cdot (t - C), 2,5 \cdot (t_n - C_n) + t_e] \\
 &= \min [2,5 \cdot (7,16 - 3), 2,5 \cdot (7,14 - 3) + 0] \\
 &= 10,34 \text{ mm}
 \end{aligned}$$

Nozzle required thickness per UG-27(c)(1)

$$\begin{aligned}
 t_{rn} &= \frac{P \cdot R_n}{S_n \cdot E - 0,6 \cdot P} \\
 &= \frac{45,4851 \cdot 19,99}{1,180 \cdot 1 - 0,6 \cdot 45,4851} \\
 &= 0,79 \text{ mm}
 \end{aligned}$$

Required thickness t_r from UG-37(a)

$$\begin{aligned}
 t_r &= \frac{P \cdot R_o}{S \cdot E + 0,4 \cdot P} \\
 &= \frac{45,4851 \cdot 109,54}{1,180 \cdot 1 + 0,4 \cdot 45,4851} \\
 &= 4,16 \text{ mm}
 \end{aligned}$$

Required thickness t_r per Interpretation VIII-1-07-50

$$\begin{aligned}
t_r &= \frac{P \cdot R_o}{S \cdot E + 0,4 \cdot P} \\
&= \frac{45,4851 \cdot 109,54}{1.180 \cdot 0,85 + 0,4 \cdot 45,4851} \\
&= 4,88 \text{ mm}
\end{aligned}$$

This opening does not require reinforcement per UG-36(c)(3)(a)

UW-16(c) Weld Check

Fillet weld: $t_{\min} = \min [19\text{mm}, t_n, t] = 4,14 \text{ mm}$

$t_{c(\min)} = \min [6 \text{ mm}, 0,7 \cdot t_{\min}] = 2,9 \text{ mm}$

$t_{c(\text{actual})} = 0,7 \cdot \text{Leg} = 0,7 \cdot 7,5 = 5,25 \text{ mm}$

The fillet weld size is satisfactory.

Weld strength calculations are not required for this detail which conforms to Fig. UW-16.1, sketch (c-e).

UG-45 Nozzle Neck Thickness Check

$$\begin{aligned}
t_{aUG-27} &= \frac{P \cdot R_n}{S_n \cdot E - 0,6 \cdot P} + \text{Corrosion} \\
&= \frac{45,4851 \cdot 19,99}{1.180 \cdot 1 - 0,6 \cdot 45,4851} + 3 \\
&= 3,79 \text{ mm}
\end{aligned}$$

$$\begin{aligned}
t_a &= \max [t_{aUG-27}, t_{aUG-22}] \\
&= \max [3,79, 0] \\
&= 3,79 \text{ mm}
\end{aligned}$$

$$\begin{aligned}
t_{b1} &= \frac{P \cdot R_o}{S \cdot E + 0,4 \cdot P} + \text{Corrosion} \\
&= \frac{45,4851 \cdot 109,54}{1.180 \cdot 1 + 0,4 \cdot 45,4851} + 3 \\
&= 7,16 \text{ mm}
\end{aligned}$$

$$\begin{aligned}
t_{b1} &= \max [t_{b1}, t_{bUG16}] \\
&= \max [7,16, 4,5] \\
&= 7,16 \text{ mm}
\end{aligned}$$

$$\begin{aligned}
t_b &= \min [t_{b3}, t_{b1}] \\
&= \min [6,22, 7,16] \\
&= 6,22 \text{ mm}
\end{aligned}$$

$$\begin{aligned}
t_{UG-45} &= \max [t_a, t_b] \\
&= \max [3,79, 6,22] \\
&= 6,22 \text{ mm}
\end{aligned}$$

Available nozzle wall thickness new, $t_n = 0,875 \cdot 7,14 = 6,25$ mm

The nozzle neck thickness is adequate.

Reinforcement Calculations for MAP

The attached ASME B16.5 flange limits the nozzle MAP.

UG-37 Area Calculation Summary (cm ²)						UG-45 Summary (mm)		
For P = 51,1 bar @ 21,11 °C						The nozzle passes UG-45		
A required	A available	A ₁	A ₂	A ₃	A ₅	A welds	t _{req}	t _{min}
This nozzle is exempt from area calculations per UG-36(c)(3)(a)						3,22	6,25	

UG-41 Weld Failure Path Analysis Summary
The nozzle is exempt from weld strength calculations per UW-15(b)(2)

Calculations for internal pressure 51,1 bar @ 21,11 °C

Parallel Limit of reinforcement per UG-40

$$\begin{aligned}
 L_R &= \max [d, R_n + (t_n - C_n) + (t - C)] \\
 &= \max [33,99, 16,99 + (7,14 - 0) + (7,16 - 0)] \\
 &= 33,99 \text{ mm}
 \end{aligned}$$

Outer Normal Limit of reinforcement per UG-40

$$\begin{aligned}
 L_H &= \min [2,5 \cdot (t - C), 2,5 \cdot (t_n - C_n) + t_e] \\
 &= \min [2,5 \cdot (7,16 - 0), 2,5 \cdot (7,14 - 0) + 0] \\
 &= 17,84 \text{ mm}
 \end{aligned}$$

Nozzle required thickness per UG-27(c)(1)

$$\begin{aligned}
 t_{rn} &= \frac{P \cdot R_n}{S_n \cdot E - 0,6 \cdot P} \\
 &= \frac{51,1 \cdot 16,99}{1.180 \cdot 1 - 0,6 \cdot 51,1} \\
 &= 0,75 \text{ mm}
 \end{aligned}$$

Required thickness t_r from UG-37(a)

$$\begin{aligned}
 t_r &= \frac{P \cdot R_o}{S \cdot E + 0,4 \cdot P} \\
 &= \frac{51,1 \cdot 109,54}{1.180 \cdot 1 + 0,4 \cdot 51,1} \\
 &= 4,66 \text{ mm}
 \end{aligned}$$

Required thickness t_r per Interpretation VIII-1-07-50

$$\begin{aligned}
 t_r &= \frac{P \cdot R_o}{S \cdot E + 0,4 \cdot P} \\
 &= \frac{51,1 \cdot 109,54}{1.180 \cdot 0,85 + 0,4 \cdot 51,1} \\
 &= 5,47 \text{ mm}
 \end{aligned}$$

This opening does not require reinforcement per UG-36(c)(3)(a)

UG-45 Nozzle Neck Thickness Check

$$\begin{aligned}t_{aUG-27} &= \frac{P \cdot R_n}{S_n \cdot E - 0,6 \cdot P} + \text{Corrosion} \\ &= \frac{51,1 \cdot 16,99}{1.180 \cdot 1 - 0,6 \cdot 51,1} + 0 \\ &= 0,75 \text{ mm}\end{aligned}$$

$$\begin{aligned}t_a &= \max [t_{aUG-27}, t_{aUG-22}] \\ &= \max [0,75, 0] \\ &= 0,75 \text{ mm}\end{aligned}$$

$$\begin{aligned}t_{b1} &= \frac{P \cdot R_o}{S \cdot E + 0,4 \cdot P} + \text{Corrosion} \\ &= \frac{51,1 \cdot 109,54}{1.180 \cdot 1 + 0,4 \cdot 51,1} + 0 \\ &= 4,66 \text{ mm}\end{aligned}$$

$$\begin{aligned}t_{b1} &= \max [t_{b1}, t_{bUG16}] \\ &= \max [4,66, 1,5] \\ &= 4,66 \text{ mm}\end{aligned}$$

$$\begin{aligned}t_b &= \min [t_{b3}, t_{b1}] \\ &= \min [3,22, 4,66] \\ &= 3,22 \text{ mm}\end{aligned}$$

$$\begin{aligned}t_{UG-45} &= \max [t_a, t_b] \\ &= \max [0,75, 3,22] \\ &= \underline{3,22} \text{ mm}\end{aligned}$$

Available nozzle wall thickness new, $t_n = 0,875 \cdot 7,14 = 6,25 \text{ mm}$

The nozzle neck thickness is adequate.

PSV Connection (N5)

ASME Section VIII Division 1, 2021 Edition Metric

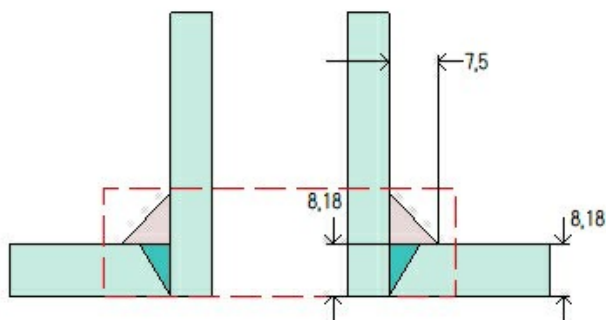

Note: round inside edges per UG-76(c)

Location and Orientation

Located on	Cylinder #1
Orientation	0°
Nozzle center line offset to datum line	280 mm
End of nozzle to shell center	250 mm
Passes through a Category A joint	No

Nozzle

Description	NPS 1 Sch 160 DN 25
Access opening	No
Material specification	SA-106 B Smls Pipe (II-D Metric p. 16, In. 16)
Inside diameter, new	20,7 mm
Pipe nominal wall thickness	6,35 mm
Pipe minimum wall thickness ¹	5,56 mm
Corrosion allowance	3 mm
Projection available outside vessel, L _{pr}	78,49 mm
Projection available outside vessel to flange face, L _f	140,47 mm
Local vessel minimum thickness	7,16 mm
Liquid static head included	0 bar

Welds

Inner fillet, Leg ₄₁	7,5 mm
Nozzle to vessel groove weld	8,18 mm

Radiography

Longitudinal seam	Seamless No RT
Circumferential seam	Full UW-11(a) Type 1

¹Pipe minimum thickness = nominal thickness times pipe tolerance factor of 0,875.

ASME B16.5-2017 Flange	
Description	NPS 1 Class 300 WN A105
Bolt Material	SA-193 B7 Bolt <= 64 (II-D Metric p. 410, ln. 32)
Blind included	No
Rated MDMT	-48°C
Liquid static head	0 bar
MAWP rating	48,35 bar @ 75°C
MAP rating	51,1 bar @ 21,11°C
Hydrotest rating	77 bar @ 21,11°C
PWHT performed	No
Produced to Fine Grain Practice and Supplied in Heat Treated Condition	No
Impact Tested	No
Circumferential joint radiography	Full UW-11(a) Type 1
Gasket	
Type	ASME B16.20 Spiral-Wound
Description	Garlock FLEXSEAL RW 316L SS / Flexible Graphite
Factor, m	3
Seating Stress, y	703,07 kg _f /cm ²
Thickness, T	3 mm
Inner Diameter	31,8 mm
Outer Diameter	47,8 mm
Notes	
Flange rated MDMT per UCS-66(b)(1)(b) = -48°C (Coincident ratio = 0,3611) Bolts rated MDMT per Fig UCS-66 note (c) = -48°C	

UCS-66 Material Toughness Requirements Nozzle	
Impact test exempt per UCS-66(d) (NPS 4 or smaller pipe) =	-105°C
Material is exempt from impact testing at the Design MDMT of 0°C.	

Reinforcement Calculations for Internal Pressure

UG-37 Area Calculation Summary (cm ²)							UG-45 Summary (mm)	
For P = 12,5 bar @ 75 °C							The nozzle passes UG-45	
A required	A available	A ₁	A ₂	A ₃	A ₅	A welds	t _{req}	t _{min}
This nozzle is exempt from area calculations per UG-36(c)(3)(a)							4,5	5,56

UG-41 Weld Failure Path Analysis Summary
The nozzle is exempt from weld strength calculations per UW-15(b)(2)

UW-16 Weld Sizing Summary			
Weld description	Required weld throat size (mm)	Actual weld throat size (mm)	Status
Nozzle to shell fillet (Leg ₄₁)	2,35	5,25	weld size is adequate

Calculations for internal pressure 12,5 bar @ 75 °C

Parallel Limit of reinforcement per UG-40

$$\begin{aligned}
 L_R &= \max [d, R_n + (t_n - C_n) + (t - C)] \\
 &= \max [26,7, 13,35 + (6,35 - 3) + (7,16 - 3)] \\
 &= 26,7 \text{ mm}
 \end{aligned}$$

Outer Normal Limit of reinforcement per UG-40

$$\begin{aligned}
 L_H &= \min [2,5 \cdot (t - C), 2,5 \cdot (t_n - C_n) + t_e] \\
 &= \min [2,5 \cdot (7,16 - 3), 2,5 \cdot (6,35 - 3) + 0] \\
 &= 8,38 \text{ mm}
 \end{aligned}$$

Nozzle required thickness per UG-27(c)(1)

$$\begin{aligned}
 t_{rn} &= \frac{P \cdot R_n}{S_n \cdot E - 0,6 \cdot P} \\
 &= \frac{12,5 \cdot 13,35}{1.180 \cdot 1 - 0,6 \cdot 12,5} \\
 &= 0,14 \text{ mm}
 \end{aligned}$$

Required thickness t_r from UG-37(a)

$$\begin{aligned}
 t_r &= \frac{P \cdot R_o}{S \cdot E + 0,4 \cdot P} \\
 &= \frac{12,5 \cdot 109,54}{1.180 \cdot 1 + 0,4 \cdot 12,5} \\
 &= 1,16 \text{ mm}
 \end{aligned}$$

Required thickness t_r per Interpretation VIII-1-07-50

$$\begin{aligned}
 t_r &= \frac{P \cdot R_o}{S \cdot E + 0,4 \cdot P} \\
 &= \frac{12,5 \cdot 109,54}{1.180 \cdot 0,85 + 0,4 \cdot 12,5} \\
 &= 1,36 \text{ mm}
 \end{aligned}$$

This opening does not require reinforcement per UG-36(c)(3)(a)

UW-16(c) Weld Check

Fillet weld: $t_{\min} = \min [19\text{mm}, t_n, t] = 3,35 \text{ mm}$

$$t_{c(\min)} = \min [6 \text{ mm}, 0,7 \cdot t_{\min}] = 2,35 \text{ mm}$$

$$t_{c(\text{actual})} = 0,7 \cdot \text{Leg} = 0,7 \cdot 7,5 = 5,25 \text{ mm}$$

The fillet weld size is satisfactory.

Weld strength calculations are not required for this detail which conforms to Fig. UW-16.1, sketch (c-e).

UG-45 Nozzle Neck Thickness Check

$$\begin{aligned}
 t_{aUG-27} &= \frac{P \cdot R_n}{S_n \cdot E - 0,6 \cdot P} + \text{Corrosion} \\
 &= \frac{12,5 \cdot 13,35}{1.180 \cdot 1 - 0,6 \cdot 12,5} + 3 \\
 &= 3,14 \text{ mm}
 \end{aligned}$$

$$\begin{aligned}
 t_a &= \max [t_{aUG-27}, t_{aUG-22}] \\
 &= \max [3,14, 0] \\
 &= 3,14 \text{ mm}
 \end{aligned}$$

$$\begin{aligned}
 t_{b1} &= \frac{P \cdot R_o}{S \cdot E + 0,4 \cdot P} + \text{Corrosion} \\
 &= \frac{12,5 \cdot 109,54}{1.180 \cdot 1 + 0,4 \cdot 12,5} + 3 \\
 &= 4,16 \text{ mm}
 \end{aligned}$$

$$\begin{aligned}
 t_{b1} &= \max [t_{b1}, t_{bUG16}] \\
 &= \max [4,16, 4,5] \\
 &= 4,5 \text{ mm}
 \end{aligned}$$

$$\begin{aligned}
 t_b &= \min [t_{b3}, t_{b1}] \\
 &= \min [5,96, 4,5] \\
 &= 4,5 \text{ mm}
 \end{aligned}$$

$$\begin{aligned}
 t_{UG-45} &= \max [t_a, t_b] \\
 &= \max [3,14, 4,5] \\
 &= 4,5 \text{ mm}
 \end{aligned}$$

Available nozzle wall thickness new, $t_n = 0,875 \cdot 6,35 = 5,56$ mm

The nozzle neck thickness is adequate.

Reinforcement Calculations for MAWP

The thickness requirements of UG-45 govern the MAWP of this nozzle.

UG-37 Area Calculation Summary (cm ²)							UG-45 Summary (mm)	
For P = 27,8 bar @ 75 °C							The nozzle passes UG-45	
A required	A available	A ₁	A ₂	A ₃	A ₅	A welds	t _{req}	t _{min}
This nozzle is exempt from area calculations per UG-36(c)(3)(a)							5,56	5,56

UG-41 Weld Failure Path Analysis Summary
The nozzle is exempt from weld strength calculations per UW-15(b)(2)

UW-16 Weld Sizing Summary			
Weld description	Required weld throat size (mm)	Actual weld throat size (mm)	Status
Nozzle to shell fillet (Leg ₄₁)	2,35	5,25	weld size is adequate

Calculations for internal pressure 27,8 bar @ 75 °C

Parallel Limit of reinforcement per UG-40

$$\begin{aligned}
 L_R &= \max [d, R_n + (t_n - C_n) + (t - C)] \\
 &= \max [26,7, 13,35 + (6,35 - 3) + (7,16 - 3)] \\
 &= 26,7 \text{ mm}
 \end{aligned}$$

Outer Normal Limit of reinforcement per UG-40

$$\begin{aligned}
 L_H &= \min [2,5 \cdot (t - C), 2,5 \cdot (t_n - C_n) + t_e] \\
 &= \min [2,5 \cdot (7,16 - 3), 2,5 \cdot (6,35 - 3) + 0] \\
 &= 8,38 \text{ mm}
 \end{aligned}$$

Nozzle required thickness per UG-27(c)(1)

$$\begin{aligned}
 t_{rn} &= \frac{P \cdot R_n}{S_n \cdot E - 0,6 \cdot P} \\
 &= \frac{27,7998 \cdot 13,35}{1,180 \cdot 1 - 0,6 \cdot 27,7998} \\
 &= 0,32 \text{ mm}
 \end{aligned}$$

Required thickness t_r from UG-37(a)

$$\begin{aligned}
 t_r &= \frac{P \cdot R_o}{S \cdot E + 0,4 \cdot P} \\
 &= \frac{27,7998 \cdot 109,54}{1,180 \cdot 1 + 0,4 \cdot 27,7998} \\
 &= 2,56 \text{ mm}
 \end{aligned}$$

Required thickness t_r per Interpretation VIII-1-07-50

$$\begin{aligned}
t_r &= \frac{P \cdot R_o}{S \cdot E + 0,4 \cdot P} \\
&= \frac{27,7998 \cdot 109,54}{1.180 \cdot 0,85 + 0,4 \cdot 27,7998} \\
&= 3 \text{ mm}
\end{aligned}$$

This opening does not require reinforcement per UG-36(c)(3)(a)

UW-16(c) Weld Check

Fillet weld: $t_{\min} = \min [19\text{mm}, t_n, t] = 3,35 \text{ mm}$

$t_{c(\min)} = \min [6 \text{ mm}, 0,7 \cdot t_{\min}] = 2,35 \text{ mm}$

$t_{c(\text{actual})} = 0,7 \cdot \text{Leg} = 0,7 \cdot 7,5 = 5,25 \text{ mm}$

The fillet weld size is satisfactory.

Weld strength calculations are not required for this detail which conforms to Fig. UW-16.1, sketch (c-e).

UG-45 Nozzle Neck Thickness Check

$$\begin{aligned}
t_{aUG-27} &= \frac{P \cdot R_n}{S_n \cdot E - 0,6 \cdot P} + \text{Corrosion} \\
&= \frac{27,7998 \cdot 13,35}{1.180 \cdot 1 - 0,6 \cdot 27,7998} + 3 \\
&= 3,32 \text{ mm}
\end{aligned}$$

$$\begin{aligned}
t_a &= \max [t_{aUG-27}, t_{aUG-22}] \\
&= \max [3,32, 0] \\
&= 3,32 \text{ mm}
\end{aligned}$$

$$\begin{aligned}
t_{b1} &= \frac{P \cdot R_o}{S \cdot E + 0,4 \cdot P} + \text{Corrosion} \\
&= \frac{27,7998 \cdot 109,54}{1.180 \cdot 1 + 0,4 \cdot 27,7998} + 3 \\
&= 5,56 \text{ mm}
\end{aligned}$$

$$\begin{aligned}
t_{b1} &= \max [t_{b1}, t_{bUG16}] \\
&= \max [5,56, 4,5] \\
&= 5,56 \text{ mm}
\end{aligned}$$

$$\begin{aligned}
t_b &= \min [t_{b3}, t_{b1}] \\
&= \min [5,96, 5,56] \\
&= 5,56 \text{ mm}
\end{aligned}$$

$$\begin{aligned}
t_{UG-45} &= \max [t_a, t_b] \\
&= \max [3,32, 5,56] \\
&= 5,56 \text{ mm}
\end{aligned}$$

Available nozzle wall thickness new, $t_n = 0,875 \cdot 6,35 = 5,56$ mm

The nozzle neck thickness is adequate.

Reinforcement Calculations for MAP

The attached ASME B16.5 flange limits the nozzle MAP.

UG-37 Area Calculation Summary (cm ²)						UG-45 Summary (mm)		
For P = 51,1 bar @ 21,11 °C						The nozzle passes UG-45		
A required	A available	A ₁	A ₂	A ₃	A ₅	A welds	t _{req}	t _{min}
This nozzle is exempt from area calculations per UG-36(c)(3)(a)						2,96	5,56	

UG-41 Weld Failure Path Analysis Summary
The nozzle is exempt from weld strength calculations per UW-15(b)(2)

Calculations for internal pressure 51,1 bar @ 21,11 °C

Parallel Limit of reinforcement per UG-40

$$\begin{aligned}
 L_R &= \max [d, R_n + (t_n - C_n) + (t - C)] \\
 &= \max [20,7, 10,35 + (6,35 - 0) + (7,16 - 0)] \\
 &= 23,86 \text{ mm}
 \end{aligned}$$

Outer Normal Limit of reinforcement per UG-40

$$\begin{aligned}
 L_H &= \min [2,5 \cdot (t - C), 2,5 \cdot (t_n - C_n) + t_e] \\
 &= \min [2,5 \cdot (7,16 - 0), 2,5 \cdot (6,35 - 0) + 0] \\
 &= 15,88 \text{ mm}
 \end{aligned}$$

Nozzle required thickness per UG-27(c)(1)

$$\begin{aligned}
 t_{rn} &= \frac{P \cdot R_n}{S_n \cdot E - 0,6 \cdot P} \\
 &= \frac{51,1 \cdot 10,35}{1.180 \cdot 1 - 0,6 \cdot 51,1} \\
 &= 0,46 \text{ mm}
 \end{aligned}$$

Required thickness t_r from UG-37(a)

$$\begin{aligned}
 t_r &= \frac{P \cdot R_o}{S \cdot E + 0,4 \cdot P} \\
 &= \frac{51,1 \cdot 109,54}{1.180 \cdot 1 + 0,4 \cdot 51,1} \\
 &= 4,66 \text{ mm}
 \end{aligned}$$

Required thickness t_r per Interpretation VIII-1-07-50

$$\begin{aligned}
 t_r &= \frac{P \cdot R_o}{S \cdot E + 0,4 \cdot P} \\
 &= \frac{51,1 \cdot 109,54}{1.180 \cdot 0,85 + 0,4 \cdot 51,1} \\
 &= 5,47 \text{ mm}
 \end{aligned}$$

This opening does not require reinforcement per UG-36(c)(3)(a)

UG-45 Nozzle Neck Thickness Check

$$\begin{aligned}t_{aUG-27} &= \frac{P \cdot R_n}{S_n \cdot E - 0,6 \cdot P} + \text{Corrosion} \\ &= \frac{51,1 \cdot 10,35}{1.180 \cdot 1 - 0,6 \cdot 51,1} + 0 \\ &= 0,46 \text{ mm}\end{aligned}$$

$$\begin{aligned}t_a &= \max [t_{aUG-27}, t_{aUG-22}] \\ &= \max [0,46, 0] \\ &= 0,46 \text{ mm}\end{aligned}$$

$$\begin{aligned}t_{b1} &= \frac{P \cdot R_o}{S \cdot E + 0,4 \cdot P} + \text{Corrosion} \\ &= \frac{51,1 \cdot 109,54}{1.180 \cdot 1 + 0,4 \cdot 51,1} + 0 \\ &= 4,66 \text{ mm}\end{aligned}$$

$$\begin{aligned}t_{b1} &= \max [t_{b1}, t_{bUG16}] \\ &= \max [4,66, 1,5] \\ &= 4,66 \text{ mm}\end{aligned}$$

$$\begin{aligned}t_b &= \min [t_{b3}, t_{b1}] \\ &= \min [2,96, 4,66] \\ &= 2,96 \text{ mm}\end{aligned}$$

$$\begin{aligned}t_{UG-45} &= \max [t_a, t_b] \\ &= \max [0,46, 2,96] \\ &= \underline{2,96} \text{ mm}\end{aligned}$$

Available nozzle wall thickness new, $t_n = 0,875 \cdot 6,35 = 5,56 \text{ mm}$

The nozzle neck thickness is adequate.

Drain (N6)

ASME Section VIII Division 1, 2021 Edition Metric

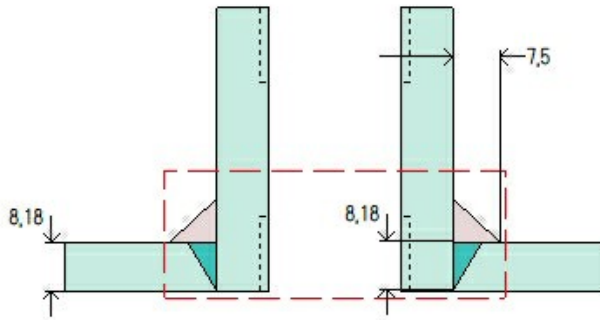

Note: round inside edges per UG-76(c)

Location and Orientation

Located on	Cylinder #1
Orientation	180°
Nozzle center line offset to datum line	420 mm
End of nozzle to shell center	147,3 mm
Passes through a Category A joint	No
Nozzle	
Description	NPS 0,5 Class 6000 DN 15 - Threaded Full Coupling
Access opening	No
Material specification	SA-105 (II-D Metric p. 20, ln. 31)
Inside diameter, new	21,34 mm
Nominal wall thickness	8,38 mm
Corrosion allowance	3 mm
Projection available outside vessel, L _{pr}	37,77 mm
Local vessel minimum thickness	7,16 mm
Liquid static head included	0 bar
Welds	
Inner fillet, Leg ₄₁	7,5 mm
Nozzle to vessel groove weld	8,18 mm
Radiography	
Longitudinal seam	Seamless No RT

UCS-66 Material Toughness Requirements Nozzle At Intersection

Governing thickness, $t_g =$	7,16 mm
Exemption temperature from Fig UCS-66M Curve B =	-29°C
$t_r = \frac{18,45 \cdot 109,54}{1.180 \cdot 1 + 0,4 \cdot 18,45} =$	1,7 mm
Stress ratio = $\frac{t_r \cdot E^*}{t_n - c} = \frac{1,7 \cdot 1}{7,16 - 3} =$	0,4094
Reduction in MDMT, T_R from Fig UCS-66.1M =	48,6°C
$MDMT = \max [MDMT - T_R, -48] = \max [-29 - 48,6, -48] =$	-48°C
Material is exempt from impact testing at the Design MDMT of 0°C.	

UCS-66 Material Toughness Requirements Nozzle	
$t_r = \frac{18,45 \cdot 13,67}{1.380 \cdot 1 - 0,6 \cdot 18,45} =$	0,18 mm
Stress ratio = $\frac{t_r \cdot E^*}{t_n - c} = \frac{0,18 \cdot 1}{8,38 - 3} =$	0,0342
Stress ratio $\leq 0,35$, MDMT per UCS-66(b)(3) =	-105°C
Material is exempt from impact testing at the Design MDMT of 0°C.	

Reinforcement Calculations for Internal Pressure

UG-37 Area Calculation Summary (cm ²)							UG-44 Summary (mm)	
For P = 12,5 bar @ 75 °C							The nozzle passes UG-44	
A required	A available	A ₁	A ₂	A ₃	A ₅	A welds	t _{req}	t _{min}
This nozzle is exempt from area calculations per UG-36(c)(3)(a)							4,5	8,38

UG-41 Weld Failure Path Analysis Summary
The nozzle is exempt from weld strength calculations per UW-15(b)(2)

UW-16 Weld Sizing Summary			
Weld description	Required weld throat size (mm)	Actual weld throat size (mm)	Status
Nozzle to shell fillet (Leg ₄₁)	2,5	5,25	weld size is adequate

Calculations for internal pressure 12,5 bar @ 75 °C

Parallel Limit of reinforcement per UG-40

$$\begin{aligned}
 L_R &= \max [d, R_n + (t_n - C_n) + (t - C)] \\
 &= \max [27,34, 13,67 + (8,38 - 3) + (7,16 - 3)] \\
 &= 27,34 \text{ mm}
 \end{aligned}$$

Outer Normal Limit of reinforcement per UG-40

$$\begin{aligned}
 L_H &= \min [2,5 \cdot (t - C), 2,5 \cdot (t_n - C_n) + t_e] \\
 &= \min [2,5 \cdot (7,16 - 3), 2,5 \cdot (8,38 - 3) + 0] \\
 &= 10,4 \text{ mm}
 \end{aligned}$$

Nozzle required thickness per UG-27(c)(1)

$$\begin{aligned}
 t_{rn} &= \frac{P \cdot R_n}{S_n \cdot E - 0,6 \cdot P} \\
 &= \frac{12,5 \cdot 13,67}{1,380 \cdot 1 - 0,6 \cdot 12,5} \\
 &= 0,12 \text{ mm}
 \end{aligned}$$

Required thickness t_r from UG-37(a)

$$\begin{aligned}
 t_r &= \frac{P \cdot R_o}{S \cdot E + 0,4 \cdot P} \\
 &= \frac{12,5 \cdot 109,54}{1,180 \cdot 1 + 0,4 \cdot 12,5} \\
 &= 1,16 \text{ mm}
 \end{aligned}$$

Required thickness t_r per Interpretation VIII-1-07-50

$$\begin{aligned}
 t_r &= \frac{P \cdot R_o}{S \cdot E + 0,4 \cdot P} \\
 &= \frac{12,5 \cdot 109,54}{1.180 \cdot 0,85 + 0,4 \cdot 12,5} \\
 &= 1,36 \text{ mm}
 \end{aligned}$$

This opening does not require reinforcement per UG-36(c)(3)(a)

UW-16(f)(2)(b) Weld Check

Fillet weld: $t_{\min} = \min [19mm, t_n, t] = 4,16 \text{ mm}$

$t_{c(\min)} = \min [2,5 \text{ mm}, 0,7 \cdot t_{\min}] = 2,5 \text{ mm}$

$t_{c(\text{actual})} = 0,7 \cdot \text{Leg} = 0,7 \cdot 7,5 = 5,25 \text{ mm}$

The fillet weld size is satisfactory.

Weld strength calculations are not required for this detail which conforms to Fig. UW-16.1, sketch (c-e).

UG-44 Thickness Check - ASME B16.11 Coupling

$$\begin{aligned}
 t_{a\text{App } 1-1} &= \frac{P \cdot R_o}{S_n \cdot E + 0,4 \cdot P} + \text{Corrosion} \\
 &= \frac{12,5 \cdot 19,05}{1.380 \cdot 1 + 0,4 \cdot 12,5} + 3 \\
 &= 3,17 \text{ mm}
 \end{aligned}$$

$$\begin{aligned}
 t_{a\text{UG-44}} &= \max [t_{a\text{App } 1-1}, t_{b\text{UG16}}] \\
 &= \max [3,17, 4,5] \\
 &= 4,5 \text{ mm}
 \end{aligned}$$

Available nozzle wall thickness new, $t_n = 8,38 \text{ mm}$

The nozzle neck thickness is adequate.

Reinforcement Calculations for MAWP

The vessel wall thickness governs the MAWP of this nozzle.

UG-37 Area Calculation Summary (cm ²)							UG-44 Summary (mm)	
For P = 45,49 bar @ 75 °C							The nozzle passes UG-44	
A required	A available	A ₁	A ₂	A ₃	A ₅	A welds	t _{req}	t _{min}
This nozzle is exempt from area calculations per UG-36(c)(3)(a)							4,5	8,38

UG-41 Weld Failure Path Analysis Summary
The nozzle is exempt from weld strength calculations per UW-15(b)(2)

UW-16 Weld Sizing Summary			
Weld description	Required weld throat size (mm)	Actual weld throat size (mm)	Status
Nozzle to shell fillet (Leg ₄₁)	2,5	5,25	weld size is adequate

Calculations for internal pressure 45,49 bar @ 75 °C

Parallel Limit of reinforcement per UG-40

$$\begin{aligned}
 L_R &= \max [d, R_n + (t_n - C_n) + (t - C)] \\
 &= \max [27,34, 13,67 + (8,38 - 3) + (7,16 - 3)] \\
 &= 27,34 \text{ mm}
 \end{aligned}$$

Outer Normal Limit of reinforcement per UG-40

$$\begin{aligned}
 L_H &= \min [2,5 \cdot (t - C), 2,5 \cdot (t_n - C_n) + t_e] \\
 &= \min [2,5 \cdot (7,16 - 3), 2,5 \cdot (8,38 - 3) + 0] \\
 &= 10,4 \text{ mm}
 \end{aligned}$$

Nozzle required thickness per UG-27(c)(1)

$$\begin{aligned}
 t_{rn} &= \frac{P \cdot R_n}{S_n \cdot E - 0,6 \cdot P} \\
 &= \frac{45,4851 \cdot 13,67}{1,380 \cdot 1 - 0,6 \cdot 45,4851} \\
 &= 0,46 \text{ mm}
 \end{aligned}$$

Required thickness t_r from UG-37(a)

$$\begin{aligned}
 t_r &= \frac{P \cdot R_o}{S \cdot E + 0,4 \cdot P} \\
 &= \frac{45,4851 \cdot 109,54}{1,180 \cdot 1 + 0,4 \cdot 45,4851} \\
 &= 4,16 \text{ mm}
 \end{aligned}$$

Required thickness t_r per Interpretation VIII-1-07-50

$$\begin{aligned}
 t_r &= \frac{P \cdot R_o}{S \cdot E + 0,4 \cdot P} \\
 &= \frac{45,4851 \cdot 109,54}{1.180 \cdot 0,85 + 0,4 \cdot 45,4851} \\
 &= 4,88 \text{ mm}
 \end{aligned}$$

This opening does not require reinforcement per UG-36(c)(3)(a)

UW-16(f)(2)(b) Weld Check

Fillet weld: $t_{\min} = \min [19\text{mm}, t_n, t] = 4,16 \text{ mm}$

$$t_{c(\min)} = \min [2,5 \text{ mm}, 0,7 \cdot t_{\min}] = 2,5 \text{ mm}$$

$$t_{c(\text{actual})} = 0,7 \cdot \text{Leg} = 0,7 \cdot 7,5 = 5,25 \text{ mm}$$

The fillet weld size is satisfactory.

Weld strength calculations are not required for this detail which conforms to Fig. UW-16.1, sketch (c-e).

UG-44 Thickness Check - ASME B16.11 Coupling

$$\begin{aligned}
 t_{a\text{App } 1-1} &= \frac{P \cdot R_o}{S_n \cdot E + 0,4 \cdot P} + \text{Corrosion} \\
 &= \frac{45,4851 \cdot 19,05}{1.380 \cdot 1 + 0,4 \cdot 45,4851} + 3 \\
 &= 3,62 \text{ mm}
 \end{aligned}$$

$$\begin{aligned}
 t_{a\text{UG-44}} &= \max [t_{a\text{App } 1-1}, t_{b\text{UG16}}] \\
 &= \max [3,62, 4,5] \\
 &= 4,5 \text{ mm}
 \end{aligned}$$

Available nozzle wall thickness new, $t_n = 8,38 \text{ mm}$

The nozzle neck thickness is adequate.

Reinforcement Calculations for MAP

The vessel wall thickness governs the MAP of this nozzle.

UG-37 Area Calculation Summary (cm ²)							UG-44 Summary (mm)	
For P = 79,18 bar @ 21,11 °C							The nozzle passes UG-44	
A required	A available	A ₁	A ₂	A ₃	A ₅	A welds	t _{req}	t _{min}
This nozzle is exempt from area calculations per UG-36(c)(3)(a)							1,5	8,38

UG-41 Weld Failure Path Analysis Summary
The nozzle is exempt from weld strength calculations per UW-15(b)(2)

Calculations for internal pressure 79,18 bar @ 21,11 °C

Parallel Limit of reinforcement per UG-40

$$\begin{aligned}
 L_R &= \max [d, R_n + (t_n - C_n) + (t - C)] \\
 &= \max [21,34, 10,67 + (8,38 - 0) + (7,16 - 0)] \\
 &= 26,21 \text{ mm}
 \end{aligned}$$

Outer Normal Limit of reinforcement per UG-40

$$\begin{aligned}
 L_H &= \min [2,5 \cdot (t - C), 2,5 \cdot (t_n - C_n) + t_e] \\
 &= \min [2,5 \cdot (7,16 - 0), 2,5 \cdot (8,38 - 0) + 0] \\
 &= 17,89 \text{ mm}
 \end{aligned}$$

Nozzle required thickness per UG-27(c)(1)

$$\begin{aligned}
 t_{rn} &= \frac{P \cdot R_n}{S_n \cdot E - 0,6 \cdot P} \\
 &= \frac{79,1797 \cdot 10,67}{1,380 \cdot 1 - 0,6 \cdot 79,1797} \\
 &= 0,64 \text{ mm}
 \end{aligned}$$

Required thickness t_r from UG-37(a)

$$\begin{aligned}
 t_r &= \frac{P \cdot R_o}{S \cdot E + 0,4 \cdot P} \\
 &= \frac{79,1797 \cdot 109,54}{1,180 \cdot 1 + 0,4 \cdot 79,1797} \\
 &= 7,16 \text{ mm}
 \end{aligned}$$

Required thickness t_r per Interpretation VIII-1-07-50

$$\begin{aligned}
 t_r &= \frac{P \cdot R_o}{S \cdot E + 0,4 \cdot P} \\
 &= \frac{79,1797 \cdot 109,54}{1,180 \cdot 0,85 + 0,4 \cdot 79,1797} \\
 &= 8,38 \text{ mm}
 \end{aligned}$$

This opening does not require reinforcement per UG-36(c)(3)(a)

UG-44 Thickness Check - ASME B16.11 Coupling

$$\begin{aligned}t_{aApp\ 1-1} &= \frac{P \cdot R_o}{S_n \cdot E + 0,4 \cdot P} + \text{Corrosion} \\&= \frac{79,1797 \cdot 19,05}{1.380 \cdot 1 + 0,4 \cdot 79,1797} + 0 \\&= 1,07 \text{ mm}\end{aligned}$$

$$\begin{aligned}t_{aUG-44} &= \max [t_{aApp\ 1-1}, t_{UG16}] \\&= \max [1,07, 1,5] \\&= 1,5 \text{ mm}\end{aligned}$$

Available nozzle wall thickness new, $t_n = 8,38 \text{ mm}$

The nozzle neck thickness is adequate.

Straight Flange on B16.9 Pipe Cap - Right Side

ASME Section VIII Division 1, 2021 Edition Metric				
Component		Cylinder		
Material		SA-234 WPB (II-D Metric p. 16, ln. 18)		
Impact Tested	Normalized	Fine Grain Practice	PWHT	Maximize MDMT/ No MAWP
No	No	No	No	No
		Design Pressure (bar)	Design Temperature (°C)	Design MDMT (°C)
Internal		12,5	75	0
Static Liquid Head				
Condition		P_s (bar)	H_s (mm)	SG
Test horizontal		0,03	351,36	1
Dimensions				
Outer Diameter		219,07 mm		
Length		44,17 mm		
Nominal Thickness		8,18 mm		
Corrosion	Inner	3 mm		
	Outer	0 mm		
Weight and Capacity				
		Weight (kg)	Capacity (liters)	
New		1,87	1,43	
Corroded		1,2	1,51	
Radiography				
Longitudinal seam		Seamless No RT		
Left Circumferential seam		Spot UW-11(b) Type 1		

Results Summary	
Governing condition	UG-16
Minimum thickness per UG-16	1,5 mm + 3 mm = 4,5 mm
Design thickness due to internal pressure (t)	4.36 mm
Maximum allowable working pressure (MAWP)	48.35 bar
Maximum allowable pressure (MAP)	77.21 bar
Rated MDMT	-105 °C

UCS-66 Material Toughness Requirements	
$t_r = \frac{18,45 \cdot 109,54}{1.180 \cdot 0,85 + 0,4 \cdot 18,45} =$	2 mm
Stress ratio = $\frac{t_r \cdot E^*}{t_n - c} = \frac{2 \cdot 0,85}{8,18 - 3} =$	0,3282
Stress ratio $\leq 0,35$, MDMT per UCS-66(b)(3) =	-105°C
Material is exempt from impact testing at the Design MDMT of 0°C.	

Design thickness, (at 75 °C) Appendix 1-1

$$t = \frac{P \cdot R_o}{S \cdot E + 0,40 \cdot P} + \text{Corrosion} = \frac{12,5 \cdot 109,54}{1.180 \cdot 0,85 + 0,40 \cdot 12,5} + 3 = \mathbf{4.36 \text{ mm}}$$

Maximum allowable working pressure, (at 75 °C) Appendix 1-1

$$P = \frac{S \cdot E \cdot t}{R_o - 0,40 \cdot t} - P_s = \frac{1.180 \cdot 0,85 \cdot 5,18}{109,54 - 0,40 \cdot 5,18} - 0 = \underline{48,35} \text{ bar}$$

Maximum allowable pressure, (at 21,11 °C) Appendix 1-1

$$P = \frac{S \cdot E \cdot t}{R_o - 0,40 \cdot t} = \frac{1.180 \cdot 0,85 \cdot 8,18}{109,54 - 0,40 \cdot 8,18} = \underline{77,21} \text{ bar}$$

ASME Section VIII Division 1 UG-80(a) Out-of-Roundness
$(D_{\max} - D_{\min})$ shall not exceed 1% of D
When the cross section passes through an opening or within 1 I.D. of the opening, $(D_{\max} - D_{\min})$ shall not exceed 1% of $D + 2\%$ of the inside diameter of the opening

B16.9 Pipe Cap - Right Side

ASME Section VIII Division 1, 2021 Edition Metric				
Component		ASME B16.9 Pipe Cap (modified)		
Material		SA-234 WPB (II-D Metric p. 16, ln. 18)		
Attached To		Cylinder #1		
Impact Tested	Normalized	Fine Grain Practice	PWHT	Maximize MDMT/ No MAWP
No	No	No	No	No
		Design Pressure (bar)	Design Temperature (°C)	Design MDMT (°C)
Internal		12,5	75	0
Static Liquid Head				
Condition		P_s (bar)	H_s (mm)	SG
Test horizontal		0,03	351,36	1
Dimensions				
NPS and Schedule		NPS 8 Sch 40 (Std) DN 200		
Outer Diameter		219,07 mm		
Overall Length E		102 mm		
Nominal Thickness		8,18 mm		
Minimum Thickness¹		7,16 mm		
Corrosion	Inner	3 mm		
	Outer	0 mm		
Length L_{sf}		44,17 mm		
Nominal Thickness t_{sf}		8,18 mm		
Weight and Capacity				
		Weight (kg)²	Capacity (liters)²	
New		5,17	2,52	
Corroded		3,36	2,74	
Radiography				
Category A joints		Seamless No RT		
Head to shell seam		Spot UW-11(b) Type 1		

¹ minimum thickness = nominal thickness times pipe tolerance factor of 0,875.

² includes straight flange

Results Summary	
Governing condition	UG-16
Minimum thickness per UG-16	1,5 mm + 3 mm = 4,5 mm
Design thickness due to internal pressure (t)	4.3 mm
Governing straight flange design thickness	4,36 mm
Maximum allowable working pressure (MAWP)	40.92 bar
Maximum allowable pressure (MAP)	69.64 bar
Straight Flange governs MDMT	-105°C

Factor K		
	$K = \left(\frac{1}{6}\right) \cdot \left[2 + \left(\frac{D}{2 \cdot h}\right)^2\right]$	
Corroded	$K = \left(\frac{1}{6}\right) \cdot \left[2 + \left(\frac{208,71}{2 \cdot 53,68}\right)^2\right]$	0,9633
New	$K = \left(\frac{1}{6}\right) \cdot \left[2 + \left(\frac{202,71}{2 \cdot 50,68}\right)^2\right]$	1

Design thickness for internal pressure, (Corroded at 75 °C) Appendix 1-4(c)

$$t = \frac{P \cdot D_o \cdot K}{2 \cdot S \cdot E + 2 \cdot P \cdot (K - 0,1)} + \text{Corrosion} = \frac{12,5 \cdot 219,07 \cdot 0,963264}{2 \cdot 1.180 \cdot 0,85 + 2 \cdot 12,5 \cdot (0,963264 - 0,1)} + 3 = 4.3 \text{ mm}$$

Maximum allowable working pressure, (Corroded at 75 °C) Appendix 1-4(c)

$$P = \frac{2 \cdot S \cdot E \cdot t}{K \cdot D_o - 2 \cdot t \cdot (K - 0,1)} - P_s = \frac{2 \cdot 1.180 \cdot 0,85 \cdot (0,875 \cdot 8,18 - 3)}{0,963264 \cdot 219,07 - 2 \cdot (0,875 \cdot 8,18 - 3) \cdot (0,963264 - 0,1)} - 0 = 40.92 \text{ bar}$$

Maximum allowable pressure, (New at 21,11 °C) Appendix 1-4(c)

$$P = \frac{2 \cdot S \cdot E \cdot t}{K \cdot D_o - 2 \cdot t \cdot (K - 0,1)} - P_s = \frac{2 \cdot 1.180 \cdot 0,85 \cdot 0,875 \cdot 8,18}{1 \cdot 219,07 - 2 \cdot 0,875 \cdot 8,18 \cdot (1 - 0,1)} - 0 = 69.64 \text{ bar}$$

ASME Section VIII Division 1 UG-81(a) Out-of-Roundness
Inside surface shall not deviate outside the shape by more than 1,25 % of D
Inside surface shall not deviate inside the shape by more than 0,625 % of D

Air Outlet (N2)

ASME Section VIII Division 1, 2021 Edition Metric

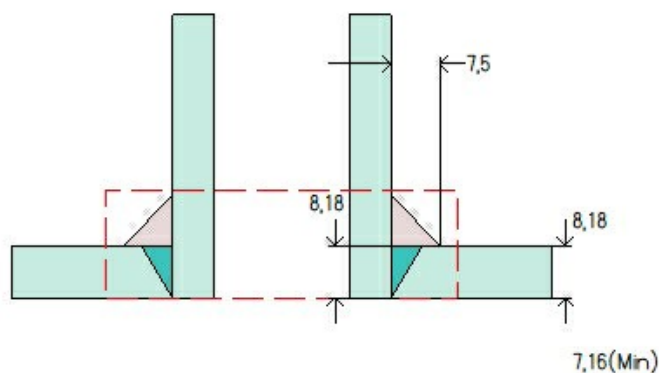

Note: round inside edges per UG-76(c)

Location and Orientation

Located on	B16.9 Pipe Cap - Right Side
Orientation	0°
End of nozzle to datum line	-166 mm
Calculated as hillside	No
Distance to head center, R	0 mm
Passes through a Category A joint	No

Nozzle

Description	NPS 1 Sch 160 DN 25
Access opening	No
Material specification	SA-106 B Smls Pipe (II-D Metric p. 16, ln. 16)
Inside diameter, new	20,7 mm
Pipe nominal wall thickness	6,35 mm
Pipe minimum wall thickness ¹	5,56 mm
Corrosion allowance	3 mm
Projection available outside vessel, Lpr	64,68 mm
Local vessel minimum thickness	7,16 mm
Liquid static head included	0 bar

Welds

Inner fillet, Leg ₄₁	7,5 mm
Nozzle to vessel groove weld	8,18 mm

Radiography

Longitudinal seam	Seamless No RT
Circumferential seam	Full UW-11(a) Type 1

¹Pipe minimum thickness = nominal thickness times pipe tolerance factor of 0,875.

UCS-66 Material Toughness Requirements Nozzle

Impact test exempt per UCS-66(d) (NPS 4 or smaller pipe) =	-105°C
Material is exempt from impact testing at the Design MDMT of 0°C.	

Reinforcement Calculations for Internal Pressure

UG-37 Area Calculation Summary (cm ²)							UG-45 Summary (mm)	
For P = 12,5 bar @ 75 °C							The nozzle passes UG-45	
A required	A available	A ₁	A ₂	A ₃	A ₅	A welds	t _{req}	t _{min}
This nozzle is exempt from area calculations per UG-36(c)(3)(a)							4,5	5,56

UG-41 Weld Failure Path Analysis Summary
The nozzle is exempt from weld strength calculations per UW-15(b)(2)

UW-16 Weld Sizing Summary			
Weld description	Required weld throat size (mm)	Actual weld throat size (mm)	Status
Nozzle to shell fillet (Leg ₄₁)	2,35	5,25	weld size is adequate

Calculations for internal pressure 12,5 bar @ 75 °C

Parallel Limit of reinforcement per UG-40

$$\begin{aligned}
 L_R &= \max [d, R_n + (t_n - C_n) + (t - C)] \\
 &= \max [26,7, 13,35 + (6,35 - 3) + (7,16 - 3)] \\
 &= 26,7 \text{ mm}
 \end{aligned}$$

Outer Normal Limit of reinforcement per UG-40

$$\begin{aligned}
 L_H &= \min [2,5 \cdot (t - C), 2,5 \cdot (t_n - C_n) + t_e] \\
 &= \min [2,5 \cdot (7,16 - 3), 2,5 \cdot (6,35 - 3) + 0] \\
 &= 8,38 \text{ mm}
 \end{aligned}$$

Nozzle required thickness per UG-27(c)(1)

$$\begin{aligned}
 t_{rn} &= \frac{P \cdot R_n}{S_n \cdot E - 0,6 \cdot P} \\
 &= \frac{12,5 \cdot 13,35}{1.180 \cdot 1 - 0,6 \cdot 12,5} \\
 &= 0,14 \text{ mm}
 \end{aligned}$$

Required thickness t_r from UG-37(a)(c)

$$\begin{aligned}
 t_r &= \frac{P \cdot K_1 \cdot D_o}{2 \cdot S \cdot E + 0,8 \cdot P} \\
 &= \frac{12,5 \cdot 0,8749 \cdot 219,07}{2 \cdot 1.180 \cdot 1 + 0,8 \cdot 12,5} \\
 &= 1,01 \text{ mm}
 \end{aligned}$$

Required thickness t_r per Interpretation VIII-1-07-50

$$t_r = \frac{P \cdot D_o \cdot K}{2 \cdot S \cdot E + 2 \cdot P \cdot (K - 0,1)} = \frac{12,5 \cdot 219,07 \cdot 0,963264}{2 \cdot 1.180 \cdot 0,85 + 2 \cdot 12,5 \cdot (0,963264 - 0,1)} = 1,3 \text{ mm}$$

This opening does not require reinforcement per UG-36(c)(3)(a)

UW-16(c) Weld Check

Fillet weld: $t_{\min} = \min [19\text{mm}, t_n, t] = 3,35 \text{ mm}$

$$t_{c(\min)} = \min [6 \text{ mm}, 0,7 \cdot t_{\min}] = \underline{2,35} \text{ mm}$$

$$t_{c(\text{actual})} = 0,7 \cdot \text{Leg} = 0,7 \cdot 7,5 = 5,25 \text{ mm}$$

The fillet weld size is satisfactory.

Weld strength calculations are not required for this detail which conforms to Fig. UW-16.1, sketch (c-e).

UG-45 Nozzle Neck Thickness Check

Interpretation VIII-1-83-66 has been applied.

$$\begin{aligned} t_{aUG-27} &= \frac{P \cdot R_n}{S_n \cdot E - 0,6 \cdot P} + \text{Corrosion} \\ &= \frac{12,5 \cdot 13,35}{1.180 \cdot 1 - 0,6 \cdot 12,5} + 3 \\ &= 3,14 \text{ mm} \end{aligned}$$

$$\begin{aligned} t_a &= \max [t_{aUG-27}, t_{aUG-22}] \\ &= \max [3,14, 0] \\ &= 3,14 \text{ mm} \end{aligned}$$

$$\begin{aligned} t_{b1} &= \frac{P \cdot D_o \cdot K}{2 \cdot S \cdot E + 2 \cdot P \cdot (K - 0,1)} + \text{Corrosion} \\ &= \frac{12,5 \cdot 219,07 \cdot 0,963264}{2 \cdot 1.180 \cdot 1 + 2 \cdot 12,5 \cdot (0,963264 - 0,1)} + 3 \\ &= 4,11 \text{ mm} \end{aligned}$$

$$\begin{aligned} t_{b1} &= \max [t_{b1}, t_{bUG16}] \\ &= \max [4,11, 4,5] \\ &= 4,5 \text{ mm} \end{aligned}$$

$$\begin{aligned} t_b &= \min [t_{b3}, t_{b1}] \\ &= \min [5,96, 4,5] \\ &= 4,5 \text{ mm} \end{aligned}$$

$$\begin{aligned} t_{UG-45} &= \max [t_a, t_b] \\ &= \max [3,14, 4,5] \\ &= \underline{4,5} \text{ mm} \end{aligned}$$

Available nozzle wall thickness new, $t_n = 0,875 \cdot 6,35 = 5,56 \text{ mm}$

The nozzle neck thickness is adequate.

Reinforcement Calculations for MAWP

The thickness requirements of UG-45 govern the MAWP of this nozzle.

UG-37 Area Calculation Summary (cm ²)						UG-45 Summary (mm)		
For P = 29,2 bar @ 75 °C						The nozzle passes UG-45		
A required	A available	A ₁	A ₂	A ₃	A ₅	A welds	t _{req}	t _{min}
This nozzle is exempt from area calculations per UG-36(c)(3)(a)						5,56	5,56	

UG-41 Weld Failure Path Analysis Summary
The nozzle is exempt from weld strength calculations per UW-15(b)(2)

UW-16 Weld Sizing Summary			
Weld description	Required weld throat size (mm)	Actual weld throat size (mm)	Status
Nozzle to shell fillet (Leg ₄₁)	2,35	5,25	weld size is adequate

Calculations for internal pressure 29,2 bar @ 75 °C

Parallel Limit of reinforcement per UG-40

$$\begin{aligned}
 L_R &= \max [d, R_n + (t_n - C_n) + (t - C)] \\
 &= \max [26,7, 13,35 + (6,35 - 3) + (7,16 - 3)] \\
 &= 26,7 \text{ mm}
 \end{aligned}$$

Outer Normal Limit of reinforcement per UG-40

$$\begin{aligned}
 L_H &= \min [2,5 \cdot (t - C), 2,5 \cdot (t_n - C_n) + t_e] \\
 &= \min [2,5 \cdot (7,16 - 3), 2,5 \cdot (6,35 - 3) + 0] \\
 &= 8,38 \text{ mm}
 \end{aligned}$$

Nozzle required thickness per UG-27(c)(1)

$$\begin{aligned}
 t_{rn} &= \frac{P \cdot R_n}{S_n \cdot E - 0,6 \cdot P} \\
 &= \frac{29,2014 \cdot 13,35}{1,180 \cdot 1 - 0,6 \cdot 29,2014} \\
 &= 0,34 \text{ mm}
 \end{aligned}$$

Required thickness t_r from UG-37(a)(c)

$$\begin{aligned}
 t_r &= \frac{P \cdot K_1 \cdot D_o}{2 \cdot S \cdot E + 0,8 \cdot P} \\
 &= \frac{29,2014 \cdot 0,8749 \cdot 219,07}{2 \cdot 1,180 \cdot 1 + 0,8 \cdot 29,2014} \\
 &= 2,35 \text{ mm}
 \end{aligned}$$

Required thickness t_r per Interpretation VIII-1-07-50

$$t_r = \frac{P \cdot D_o \cdot K}{2 \cdot S \cdot E + 2 \cdot P \cdot (K - 0,1)} = \frac{29,2 \cdot 219,07 \cdot 0,963264}{2 \cdot 1,180 \cdot 0,85 + 2 \cdot 29,2 \cdot (0,963264 - 0,1)} = 3 \text{ mm}$$

This opening does not require reinforcement per UG-36(c)(3)(a)

UW-16(c) Weld Check

Fillet weld: $t_{\min} = \min [19\text{mm}, t_n, t] = 3,35 \text{ mm}$

$t_{c(\min)} = \min [6 \text{ mm}, 0,7 \cdot t_{\min}] = 2,35 \text{ mm}$

$t_{c(\text{actual})} = 0,7 \cdot \text{Leg} = 0,7 \cdot 7,5 = 5,25 \text{ mm}$

The fillet weld size is satisfactory.

Weld strength calculations are not required for this detail which conforms to Fig. UW-16.1, sketch (c-e).

UG-45 Nozzle Neck Thickness Check

Interpretation VIII-1-83-66 has been applied.

$$\begin{aligned} t_{aUG-27} &= \frac{P \cdot R_n}{S_n \cdot E - 0,6 \cdot P} + \text{Corrosion} \\ &= \frac{29,2014 \cdot 13,35}{1,180 \cdot 1 - 0,6 \cdot 29,2014} + 3 \\ &= 3,34 \text{ mm} \end{aligned}$$

$$\begin{aligned} t_a &= \max [t_{aUG-27}, t_{aUG-22}] \\ &= \max [3,34, 0] \\ &= 3,34 \text{ mm} \end{aligned}$$

$$\begin{aligned} t_{b1} &= \frac{P \cdot D_o \cdot K}{2 \cdot S \cdot E + 2 \cdot P \cdot (K - 0,1)} + \text{Corrosion} \\ &= \frac{29,2 \cdot 219,07 \cdot 0,963264}{2 \cdot 1,180 \cdot 1 + 2 \cdot 29,2 \cdot (0,963264 - 0,1)} + 3 \\ &= 5,56 \text{ mm} \end{aligned}$$

$$\begin{aligned} t_{b1} &= \max [t_{b1}, t_{bUG16}] \\ &= \max [5,56, 4,5] \\ &= 5,56 \text{ mm} \end{aligned}$$

$$\begin{aligned} t_b &= \min [t_{b3}, t_{b1}] \\ &= \min [5,96, 5,56] \\ &= 5,56 \text{ mm} \end{aligned}$$

$$\begin{aligned} t_{UG-45} &= \max [t_a, t_b] \\ &= \max [3,34, 5,56] \\ &= 5,56 \text{ mm} \end{aligned}$$

Available nozzle wall thickness new, $t_n = 0,875 \cdot 6,35 = 5,56 \text{ mm}$

The nozzle neck thickness is adequate.

Reinforcement Calculations for MAP

The vessel wall thickness governs the MAP of this nozzle.

UG-37 Area Calculation Summary (cm ²)							UG-45 Summary (mm)	
For P = 88,24 bar @ 21,11 °C							The nozzle passes UG-45	
A required	A available	A ₁	A ₂	A ₃	A ₅	A welds	t _{req}	t _{min}
This nozzle is exempt from area calculations per UG-36(c)(3)(a)							2,96	5,56

UG-41 Weld Failure Path Analysis Summary
The nozzle is exempt from weld strength calculations per UW-15(b)(2)

Calculations for internal pressure 88,24 bar @ 21,11 °C

Parallel Limit of reinforcement per UG-40

$$\begin{aligned}
 L_R &= \max [d, R_n + (t_n - C_n) + (t - C)] \\
 &= \max [20,7, 10,35 + (6,35 - 0) + (7,16 - 0)] \\
 &= 23,86 \text{ mm}
 \end{aligned}$$

Outer Normal Limit of reinforcement per UG-40

$$\begin{aligned}
 L_H &= \min [2,5 \cdot (t - C), 2,5 \cdot (t_n - C_n) + t_e] \\
 &= \min [2,5 \cdot (7,16 - 0), 2,5 \cdot (6,35 - 0) + 0] \\
 &= 15,88 \text{ mm}
 \end{aligned}$$

Nozzle required thickness per UG-27(c)(1)

$$\begin{aligned}
 t_{rn} &= \frac{P \cdot R_n}{S_n \cdot E - 0,6 \cdot P} \\
 &= \frac{88,237 \cdot 10,35}{1,180 \cdot 1 - 0,6 \cdot 88,237} \\
 &= 0,81 \text{ mm}
 \end{aligned}$$

Required thickness t_r from UG-37(a)(c)

$$\begin{aligned}
 t_r &= \frac{P \cdot K_1 \cdot D_o}{2 \cdot S \cdot E + 0,8 \cdot P} \\
 &= \frac{88,237 \cdot 0,9 \cdot 219,07}{2 \cdot 1,180 \cdot 1 + 0,8 \cdot 88,237} \\
 &= 7,16 \text{ mm}
 \end{aligned}$$

Required thickness t_r per Interpretation VIII-1-07-50

$$t_r = \frac{P \cdot D_o \cdot K}{2 \cdot S \cdot E + 2 \cdot P \cdot (K - 0,1)} = \frac{88,24 \cdot 219,07 \cdot 1}{2 \cdot 1,180 \cdot 0,85 + 2 \cdot 88,24 \cdot (1 - 0,1)} = 8,93 \text{ mm}$$

This opening does not require reinforcement per UG-36(c)(3)(a)

UG-45 Nozzle Neck Thickness Check

Interpretation VIII-1-83-66 has been applied.

$$\begin{aligned}t_{aUG-27} &= \frac{P \cdot R_n}{S_n \cdot E - 0,6 \cdot P} + \text{Corrosion} \\ &= \frac{88,237 \cdot 10,35}{1.180 \cdot 1 - 0,6 \cdot 88,237} + 0 \\ &= 0,81 \text{ mm}\end{aligned}$$

$$\begin{aligned}t_a &= \max [t_{aUG-27}, t_{aUG-22}] \\ &= \max [0,81, 0] \\ &= 0,81 \text{ mm}\end{aligned}$$

$$\begin{aligned}t_{b1} &= \frac{P \cdot D_o \cdot K}{2 \cdot S \cdot E + 2 \cdot P \cdot (K - 0,1)} + \text{Corrosion} \\ &= \frac{88,24 \cdot 219,07 \cdot 1}{2 \cdot 1.180 \cdot 1 + 2 \cdot 88,24 \cdot (1 - 0,1)} + 0 \\ &= 7,67 \text{ mm}\end{aligned}$$

$$\begin{aligned}t_{b1} &= \max [t_{b1}, t_{bUG16}] \\ &= \max [7,67, 1,5] \\ &= 7,67 \text{ mm}\end{aligned}$$

$$\begin{aligned}t_b &= \min [t_{b3}, t_{b1}] \\ &= \min [2,96, 7,67] \\ &= 2,96 \text{ mm}\end{aligned}$$

$$\begin{aligned}t_{UG-45} &= \max [t_a, t_b] \\ &= \max [0,81, 2,96] \\ &= 2,96 \text{ mm}\end{aligned}$$

Available nozzle wall thickness new, $t_n = 0,875 \cdot 6,35 = 5,56 \text{ mm}$

The nozzle neck thickness is adequate.

B16.9 Elbow #2 (N2)

ASME Section VIII Division 1, 2021 Edition Metric				
Component		ASME B16.9 Elbow		
Type		Long Radius 90-deg		
Material		SA-234 WPB (II-D Metric p. 16, ln. 18)		
Pipe NPS and Schedule		NPS 1 Sch 160 DN 25		
Attached To		Air Outlet (N2)		
Impact Tested	Normalized	Fine Grain Practice	PWHT	Maximize MDMT/ No MAWP
No	No	No	No	No
		Design Pressure (bar)	Design Temperature (°C)	Design MDMT (°C)
Internal		12,5	75	0
Static Liquid Head				
Condition		P_s (bar)	H_s (mm)	SG
Test horizontal		0,03	260,35	1
Dimensions				
Outer Diameter		33,4 mm		
Nominal Thickness		6,35 mm		
Minimum Thickness¹		5,56 mm		
Center-to-End, A		38 mm		
Corrosion	Inner	3 mm		
	Outer	0 mm		
Weight and Capacity				
		Weight (kg)	Capacity (liters)	
New		0,25	0,02	
Corroded		0,15	0,03	
Radiography				
Longitudinal seam		Seamless No RT		
Left Circumferential seam		Full UW-11(a) Type 1		
Right Circumferential seam		Full UW-11(a) Type 1		

¹ minimum thickness = nominal thickness times pipe tolerance factor of 0,875.

ASME B16.5-2017 Flange	
Description	NPS 1 Class 300 WN A105
Bolt Material	SA-193 B7 Bolt <= 64 (II-D Metric p. 410, ln. 32)
Blind included	No
Rated MDMT	-48°C
Liquid static head	0 bar
MAWP rating	48,35 bar @ 75°C
MAP rating	51,1 bar @ 21,11°C
Hydrotest rating	77 bar @ 21,11°C
PWHT performed	No
Produced to Fine Grain Practice and Supplied in Heat Treated Condition	No
Impact Tested	No
Circumferential joint radiography	Full UW-11(a) Type 1
Gasket	
Type	ASME B16.21 Nonmetallic Flat Gasket
Description	Flexitallic Compressed Fiber SF 2401 Synthetic/NBR
Factor, m	3,2
Seating Stress, y	203,89 kg _f /cm ²
Thickness, T	3 mm
Inner Diameter	33 mm
Outer Diameter	73 mm
Notes	
Flange rated MDMT per UCS-66(b)(1)(b) = -48°C (Coincident ratio = 0,3611) Bolts rated MDMT per Fig UCS-66 note (c) = -48°C	

Results Summary	
Governing condition	UG-16
Minimum thickness per UG-16	1,5 mm + 3 mm = 4,5 mm
Design thickness due to internal pressure (t)	3.18 mm
Maximum allowable working pressure (MAWP)	192.42 bar
Maximum allowable pressure (MAP)	477.33 bar
Rated MDMT	-105 °C

UCS-66 Material Toughness Requirements	
$t_r = \frac{18,45 \cdot 16,7}{1.180 \cdot 1 + 0,4 \cdot 18,45} =$	0,26 mm
Stress ratio = $\frac{t_r \cdot E^*}{t_n - c} = \frac{0,26 \cdot 1}{5,56 - 3} =$	0,1015
Stress ratio ≤ 0,35, MDMT per UCS-66(b)(3) =	-105°C
Material is exempt from impact testing at the Design MDMT of 0°C.	

Design thickness, (at 75 °C) Appendix 1-1

$$t = \frac{P \cdot R_o}{S \cdot E + 0,40 \cdot P} + \text{Corrosion} = \frac{12,5 \cdot 16,7}{1.180 \cdot 1,00 + 0,40 \cdot 12,5} + 3 = \underline{3.18} \text{ mm}$$

Maximum allowable working pressure, (at 75 °C) Appendix 1-1

$$P = \frac{S \cdot E \cdot t}{R_o - 0,40 \cdot t} - P_s = \frac{1.180 \cdot 1,00 \cdot (6,35 \cdot 0,875 - 3)}{16,7 - 0,40 \cdot (6,35 \cdot 0,875 - 3)} - 0 = \underline{192.42} \text{ bar}$$

Maximum allowable pressure, (at 21,11 °C) Appendix 1-2

$$P = S \cdot E \cdot \ln\left(\frac{R_o}{R_o - t}\right) = 1.180 \cdot 1,00 \cdot \ln\left(\frac{16,7}{16,7 - (6,35 \cdot 0,875)}\right) = \underline{477,33} \text{ bar}$$

Locati Impianti Srl

Via Vittorio Veneto, 37 - Verdellino - Bergamo - Italy

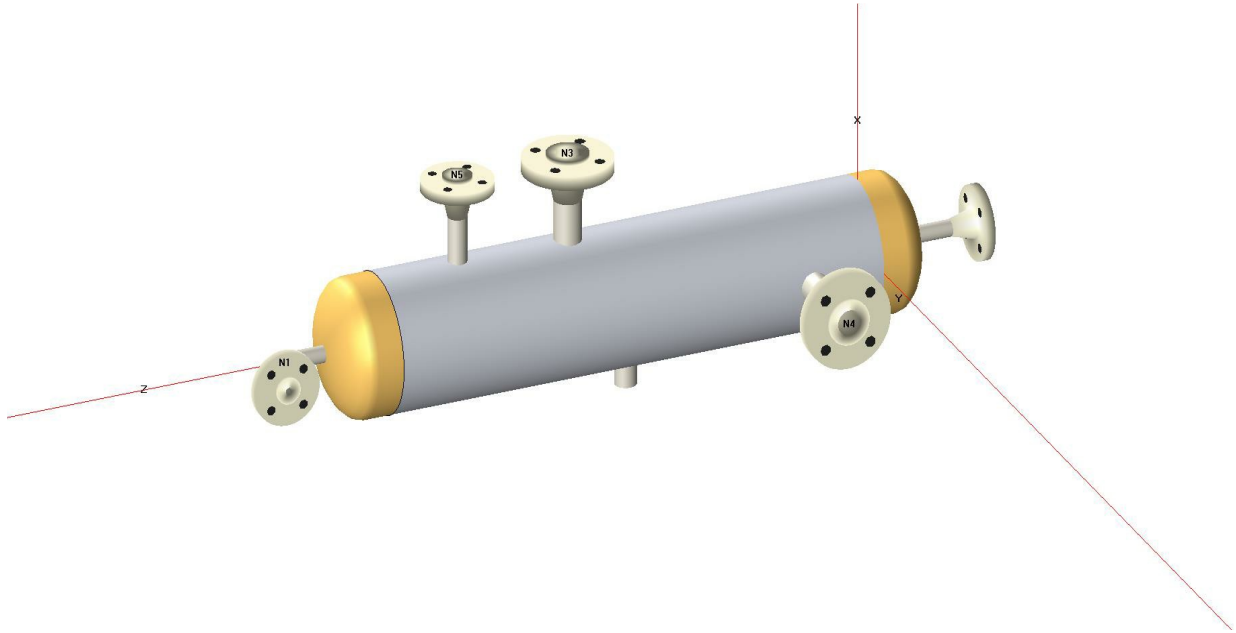

COMPRESS Pressure Vessel Design Calculations

Item: LI 5060

Customer: Airpack

Drawing No.: C230048DWG002

Document No.: C230048CLC006 Rev.02

Date: 03/08/2024

Service: 1st Stage Outlet Pulsation Damper

Tag Number: 320-KV-020-002

Table of Contents

Nozzle Schedule	1
Nozzle Summary	2
Pressure Summary	3
Settings Summary	4
Radiography Summary	6
Thickness Summary	7
Weight Summary	8
Hydrostatic Test	9
B16.9 Pipe Cap - Left Side	10
Straight Flange on B16.9 Pipe Cap - Left Side	12
Air Inlet (N1)	14
B16.9 Elbow #1 (N1)	22
Cylinder #1	25
Temperature Gauge Connection (N3)	27
Temperature Transmitter Connection (N4)	37
PSV Connection (N5)	47
Drain (N6)	57
Straight Flange on B16.9 Pipe Cap - Right Side	65
B16.9 Pipe Cap - Right Side	67
Air Outlet (N2)	69

Nozzle Schedule

Specifications									
Nozzle mark	Identifier	Size	Materials		Impact Tested	Normalized	Fine Grain	Flange	Blind
N1	Air Inlet	NPS 0,75 XXS DN 20	Nozzle	SA-106 B Smls Pipe	No	No	No	N/A	No
	B16.9 Elbow #1 (N1)	NPS 0,75 XXS DN 20	B16.9 Elbow	SA-234 WPB	No	No	No	NPS 3/4 Class 600 WN A105	No
N2	Air Outlet	NPS 0,75 XXS DN 20	Nozzle	SA-106 B Smls Pipe	No	No	No	NPS 3/4 Class 600 WN A105	No
N3	Temperature Gauge Connection	NPS 1,5 Sch 160 DN 40	Nozzle	SA-106 B Smls Pipe	No	No	No	NPS 1 1/2 Class 600 WN A105	No
N4	Temperature Transmitter Connection	NPS 1,5 Sch 160 DN 40	Nozzle	SA-106 B Smls Pipe	No	No	No	NPS 1 1/2 Class 600 WN A105	No
N5	PSV Connection	NPS 1 XXS DN 25	Nozzle	SA-106 B Smls Pipe	No	No	No	NPS 1 Class 600 WN A105	No
N6	Drain	NPS 0,5 Class 6000 DN 15 - Threaded Full Coupling	Nozzle	SA-105	No	No	No	N/A	No

Nozzle Summary

Dimensions												
Nozzle mark	OD (mm)	t _n (mm)	Req t _n (mm)	A ₁ ?	A ₂ ?	Shell			Reinforcement Pad		Corr (mm)	A _a /A _r (%)
						Nom t (mm)	Design t (mm)	User t (mm)	Width (mm)	t _{pad} (mm)		
N1	26,67	7,82	6,3	Yes	Yes	8,18	N/A		N/A	N/A	3	Exempt
N2	26,67	7,82	6,3	Yes	Yes	8,18	N/A		N/A	N/A	3	Exempt
N3	48,26	7,14	7,11	Yes	Yes	8,18	N/A		N/A	N/A	3	Exempt
N4	48,26	7,14	7,11	Yes	Yes	8,18	N/A		N/A	N/A	3	Exempt
N5	33,4	9,09	6,81	Yes	Yes	8,18	N/A		N/A	N/A	3	Exempt
N6	38,1	8,38	4,5	Yes	Yes	8,18	N/A		N/A	N/A	3	Exempt

*Head minimum thickness after forming

Repetitive comment: As per drawing thickness of N3 is 9.09 and N5 is 7.14. please revise.

Definitions	
t _n	Nozzle thickness
Req t _n	Nozzle thickness required per UG-45/UG-16 Increased for pipe to account for 12.5% pipe thickness tolerance
Nom t	Vessel wall thickness
Design t	Required vessel wall thickness due to pressure + corrosion allowance per UG-37
User t	Local vessel wall thickness (near opening)
A _a	Area available per UG-37, governing condition
A _r	Area required per UG-37, governing condition
Corr	Corrosion allowance on nozzle wall

Pressure Summary

Component Summary							
Identifier	P Design (bar)	T Design (°C)	MAWP (bar)	MAP (bar)	MDMT (°C)	MDMT Exemption	Impact Tested
B16.9 Pipe Cap - Left Side	30,5	175	40,92	69,64	-46,8	Note 1	No
Straight Flange on B16.9 Pipe Cap - Left Side	30,5	175	48,35	77,21	-46,8	Note 2	No
Cylinder #1	30,5	175	38,66	67,3	-37,4	Note 3	No
Straight Flange on B16.9 Pipe Cap - Right Side	30,5	175	48,35	77,21	-46,8	Note 2	No
B16.9 Pipe Cap - Right Side	30,5	175	40,92	69,64	-46,8	Note 4	No
Air Inlet (N1)	30,5	175	52,1	88,24	-105	Note 5	No
B16.9 Elbow #1 (N1)	30,5	175	88,9	102,1	-48	Note 6, 7	No
Air Outlet (N2)	30,5	175	52,1	88,24	-48	Note 8	No
Temperature Gauge Connection (N3)	30,5	175	45,48	79,18	-48	Note 8	No
Temperature Transmitter Connection (N4)	30,5	175	45,48	79,18	-48	Note 8	No
PSV Connection (N5)	30,5	175	45,48	79,18	-37,3	Note 9	No
Drain (N6)	30,5	175	45,48	79,18	-37,3	Note 9	No

Chamber Summary	
Design MDMT	0 °C
Rated MDMT	0 °C @ 38,66 bar
MAWP hot & corroded	38,66 bar @ 175 °C
MAP cold & new	67,3 bar @ 21,11 °C
(1) The rated MDMT is limited to the design MDMT based on the setting in the Calculations tab of the Set Mode dialog. (2) This pressure chamber is not designed for external pressure.	

Notes for MDMT Rating		
Note #	Exemption	Details
1.	Straight Flange governs MDMT	
2.	Material impact test exemption temperature from Fig UCS-66M Curve B = -29°C Fig UCS-66.1M MDMT reduction = 17,8°C, (coincident ratio = 0,6822)	UCS-66 governing thickness = 7,16 mm
3.	Material impact test exemption temperature from Fig UCS-66M Curve B = -29°C Fig UCS-66.1M MDMT reduction = 8,4°C, (coincident ratio = 0,85)	UCS-66 governing thickness = 7,16 mm
4.	Straight Flange governs MDMT	
5.	Nozzle is impact test exempt to -105°C per UCS-66(b)(3) (coincident ratio = 0,074).	
6.	Material is impact test exempt to -105°C per UCS-66(b)(3) (coincident ratio = 0,1118)	
7.	Flange rating governs: Flange rated MDMT per UCS-66(b)(1)(b) = -48°C (Coincident ratio = 0,3786)	Bolts rated MDMT per Fig UCS-66 note (c) = -48°C
8.	Flange rating governs: Flange rated MDMT per UCS-66(b)(1)(b) = -48°C (Coincident ratio = 0,3786) Bolts rated MDMT per Fig UCS-66 note (c) = -48°C	
9.	Nozzle impact test exemption temperature from Fig UCS-66M Curve B = -29°C Fig UCS-66.1M MDMT reduction = 8,3°C, (coincident ratio = 0,8519)	UCS-66 governing thickness = 7,16 mm.

Settings Summary

COMPRESS 2024 Build 8400	
ASME Section VIII Division 1, 2021 Edition Metric	
Units	MKS
Datum Line Location	0,00 mm from right seam
Vessel Design Mode	Design Mode
Minimum thickness	1,5 mm per UG-16(b)
Design for cold shut down only	No
Design for lethal service (full radiography required)	No
Design nozzles for	Design P only
Corrosion weight loss	100% of theoretical loss
UG-23 Stress Increase	1,20
Skirt/legs stress increase	1,0
Minimum nozzle projection	60 mm
Juncture calculations for $\alpha > 30$ only	Yes
Preheat P-No 1 Materials $> 1,25"$ and $\leq 1,50"$ thick	No
UG-37(a) shell tr calculation considers longitudinal stress	No
Cylindrical shells made from pipe are entered as minimum thickness	No
Nozzles made from pipe are entered as minimum thickness	No
ASME B16.9 fittings are entered as minimum thickness	No
Butt welds	Tapered per Figure UCS-66.3(a)
Disallow Appendix 1-5, 1-8 calculations under 15 psi	No
Hydro/Pneumatic Test	
Shop Hydrotest Pressure	1,3 times vessel MAWP [UG-99(b)]
Test liquid specific gravity	1,00
Maximum stress during test	90% of yield
Required Marking - UG-116	
UG-116(e) Radiography	RT3
UG-116(f) Postweld heat treatment	None
Code Cases\Interpretations	
Use Appendix 46	No
Use UG-44(b)	No
Use Code Case 3035	No
Apply interpretation VIII-1-83-66	Yes
Apply interpretation VIII-1-86-175	Yes
Apply interpretation VIII-1-01-37	Yes
Apply interpretation VIII-1-01-150	Yes
Apply interpretation VIII-1-07-50	Yes
Apply interpretation VIII-1-16-85	Yes
No UCS-66.1 MDMT reduction	No
No UCS-68(c) MDMT reduction	No
Disallow UG-20(f) exemptions	No
UG-22 Loadings	
UG-22(a) Internal or External Design Pressure	Yes
UG-22(b) Weight of the vessel and normal contents under operating or test conditions	No
UG-22(c) Superimposed static reactions from weight of attached equipment (external loads)	No
UG-22(d)(2) Vessel supports such as lugs, rings, skirts, saddles and legs	No
UG-22(f) Wind reactions	No
UG-22(f) Seismic reactions	No
UG-22(j) Test pressure and coincident static head acting during the test:	No

Note: UG-22(b),(c) and (f) loads only considered when supports are present.

Note 2: UG-22(d)(1),(e),(f)-snow,(g),(h),(i) are not considered. If these loads are present, additional calculations must be performed.

License Information	
Company Name	Locati Impianti s.r.l.
License	Commercial
License Key ID	32235
Support Expires	September 20, 2024
Account Number	891888909529634

Radiography Summary

UG-116 Radiography							
Component	Longitudinal Seam		Left Circumferential Seam		Right Circumferential Seam		Mark
	Category (Fig UW-3)	Radiography / Joint Type	Category (Fig UW-3)	Radiography / Joint Type	Category (Fig UW-3)	Radiography / Joint Type	
B16.9 Pipe Cap - Left Side	N/A	Seamless No RT	N/A	N/A	B	Spot UW-11(b) / Type 1	RT3
Cylinder #1	N/A	Seamless No RT	B	Spot UW-11(b) / Type 1	B	Spot UW-11(b) / Type 1	RT3
B16.9 Pipe Cap - Right Side	N/A	Seamless No RT	B	Spot UW-11(b) / Type 1	N/A	N/A	RT3
Nozzle	Longitudinal Seam		Nozzle to Vessel Circumferential Seam		Nozzle free end Circumferential Seam		
Air Inlet (N1)	N/A	Seamless No RT	D	N/A / Type 7	B	UW-11(b) exempt / Type 1	N/A
B16.9 Elbow #1 (N1)	N/A	Seamless No RT	B	UW-11(b) exempt / Type 1	C	UW-11(b) exempt / Type 1	N/A
Temperature Gauge Connection (N3)	N/A	Seamless No RT	D	N/A / Type 7	C	UW-11(b) exempt / Type 1	N/A
Temperature Transmitter Connection (N4)	N/A	Seamless No RT	D	N/A / Type 7	C	UW-11(b) exempt / Type 1	N/A
PSV Connection (N5)	N/A	Seamless No RT	D	N/A / Type 7	C	UW-11(b) exempt / Type 1	N/A
Drain (N6)	N/A	Seamless No RT	D	N/A / Type 7	N/A	N/A	N/A
Air Outlet (N2)	N/A	Seamless No RT	D	N/A / Type 7	C	UW-11(b) exempt / Type 1	N/A
Nozzle Flange	Longitudinal Seam		Flange Face		Nozzle to Flange Circumferential Seam		
ASME B16.5/16.47 flange attached to right end of B16.9 Elbow #1 (N1)	N/A	Seamless No RT	N/A	N/A / Gasketed	C	UW-11(b) exempt / Type 1	N/A
ASME B16.5/16.47 flange attached to Temperature Gauge Connection (N3)	N/A	Seamless No RT	N/A	N/A / Gasketed	C	UW-11(b) exempt / Type 1	N/A
ASME B16.5/16.47 flange attached to Temperature Transmitter Connection (N4)	N/A	Seamless No RT	N/A	N/A / Gasketed	C	UW-11(b) exempt / Type 1	N/A
ASME B16.5/16.47 flange attached to PSV Connection (N5)	N/A	Seamless No RT	N/A	N/A / Gasketed	C	UW-11(b) exempt / Type 1	N/A
ASME B16.5/16.47 flange attached to Air Outlet (N2)	N/A	Seamless No RT	N/A	N/A / Gasketed	C	UW-11(b) exempt / Type 1	N/A
UG-116(e) Required Marking: RT3							

Thickness Summary

Component Data								
Component Identifier	Material	Diameter (mm)	Length (mm)	Nominal t (mm)	Design t (mm)	Total Corrosion (mm)	Joint E	Load
B16.9 Pipe Cap - Left Side	SA-234 WPB	219,07 OD	57,83	8,18	6,13	3	0,85	Internal
Straight Flange on B16.9 Pipe Cap - Left Side	SA-234 WPB	219,07 OD	44,16	8,18	6,29	3	0,85	Internal
Cylinder #1	SA-106 B Smls Pipe	219,07 OD	870	8,18	6,29	3	0,85	Internal
Straight Flange on B16.9 Pipe Cap - Right Side	SA-234 WPB	219,07 OD	44,16	8,18	6,29	3	0,85	Internal
B16.9 Pipe Cap - Right Side	SA-234 WPB	219,07 OD	57,83	8,18	6,13	3	0,85	Internal

Definitions	
Nominal t	Vessel wall nominal thickness
Design t	Required vessel thickness due to governing loading + corrosion
Joint E	Longitudinal seam joint efficiency
Load	
Internal	Circumferential stress due to internal pressure governs
External	External pressure governs
Wind	Combined longitudinal stress of pressure + weight + wind governs
Seismic	Combined longitudinal stress of pressure + weight + seismic governs

Weight Summary

Weight (kg) Contributed by Vessel Elements											
Component	Metal New*	Metal Corroded	Insulation	Insulation Supports	Lining	Piping + Liquid	Operating Liquid		Test Liquid		Surface Area m ²
							New	Corroded	New	Corroded	
B16.9 Pipe Cap - Left Side	5,2	3,4	0	0	0	0	0	0	2,5	2,8	0,09
Cylinder #1	36,6	23,5	0	0	0	0	0	0	28,2	29,9	0,59
B16.9 Pipe Cap - Right Side	5,2	3,4	0	0	0	0	0	0	2,5	2,7	0,09
TOTAL:	46,9	30,2	0	0	0	0	0	0	33,2	35,5	0,77

*Shells with attached nozzles have weight reduced by material cut out for opening.

Weight (kg) Contributed by Attachments										
Component	Body Flanges		Nozzles & Flanges		Packed Beds	Trays	Tray Supports	Rings & Clips	Vertical Loads	Surface Area m ²
	New	Corroded	New	Corroded						
B16.9 Pipe Cap - Left Side	0	0	2,3	2,2	0	0	0	0	0	0,03
Cylinder #1	0	0	10,9	10,3	0	0	0	0	0	0,16
B16.9 Pipe Cap - Right Side	0	0	2,1	2	0	0	0	0	0	0,03
TOTAL:	0	0	15,3	14,4	0	0	0	0	0	0,23

Vessel Totals		
	New	Corroded
Operating Weight (kg)	62	45
Empty Weight (kg)	62	45
Test Weight (kg)	95	80
Surface Area (m ²)	1	-
Capacity** (liters)	33	35

**The vessel capacity does not include volume of nozzle, piping or other attachments.

Vessel Lift Condition	
Vessel Lift Weight, New (kg)	62
Center of Gravity from Datum (mm)	435,06

Hydrostatic Test

Horizontal shop hydrostatic test based on MAWP per UG-99(b)

$$\begin{aligned}
 \text{Gauge pressure at } 21,11^{\circ}\text{C} &= 1,3 \cdot MAWP \cdot LSR \\
 &= 1,3 \cdot 38,66 \cdot 1 \\
 &= 50,26 \text{ bar}
 \end{aligned}$$

Horizontal shop hydrostatic test				
Identifier	Local test pressure (bar)	Test liquid static head (bar)	UG-99(b) stress ratio	UG-99(b) pressure factor
B16.9 Pipe Cap - Left Side (1)	50,29	0,03	1	1,30
Straight Flange on B16.9 Pipe Cap - Left Side	50,29	0,03	1	1,30
Cylinder #1	50,29	0,03	1	1,30
Straight Flange on B16.9 Pipe Cap - Right Side	50,29	0,03	1	1,30
B16.9 Pipe Cap - Right Side	50,29	0,03	1	1,30
Air Inlet (N1)	50,28	0,03	1	1,30
Air Outlet (N2)	50,28	0,03	1	1,30
B16.9 Elbow #1 (N1)	50,28	0,03	1	1,30
Drain (N6)	50,3	0,04	1	1,30
PSV Connection (N5)	50,27	0,01	1	1,30
Temperature Gauge Connection (N3)	50,27	0,01	1	1,30
Temperature Transmitter Connection (N4)	50,28	0,03	1	1,30
(1) B16.9 Pipe Cap - Left Side limits the UG-99(b) stress ratio. (2) The zero degree angular position is assumed to be up, and the test liquid height is assumed to the top-most flange.				

The field test condition has not been investigated.

The test temperature of 21,11 °C is warmer than the minimum recommended temperature of -20,3 °C so the brittle fracture provision of UG-99(h) has been met.

B16.9 Pipe Cap - Left Side

ASME Section VIII Division 1, 2021 Edition Metric				
Component		ASME B16.9 Pipe Cap (modified)		
Material		SA-234 WPB (II-D Metric p. 16, In. 18)		
Attached To		Cylinder #1		
Impact Tested	Normalized	Fine Grain Practice	PWHT	Maximize MDMT/ No MAWP
No	No	No	No	No
		Design Pressure (bar)	Design Temperature (°C)	Design MDMT (°C)
Internal		30,5	175	0
Static Liquid Head				
Condition		P_s (bar)	H_s (mm)	SG
Test horizontal		0,03	351,36	1
Dimensions				
NPS and Schedule		NPS 8 Sch 40 (Std) DN 200		
Outer Diameter		219,07 mm		
Overall Length E		102 mm		
Nominal Thickness		8,18 mm		
Minimum Thickness¹		7,16 mm		
Corrosion	Inner	3 mm		
	Outer	0 mm		
Length L_{sf}		44,17 mm		
Nominal Thickness t_{sf}		8,18 mm		
Weight and Capacity				
		Weight (kg)²	Capacity (liters)²	
New		5,19	2,52	
Corroded		3,38	2,74	
Radiography				
Category A joints		Seamless No RT		
Head to shell seam		Spot UW-11(b) Type 1		

¹ minimum thickness = nominal thickness times pipe tolerance factor of 0,875.

² includes straight flange

Results Summary	
Governing condition	internal pressure
Minimum thickness per UG-16	1,5 mm + 3 mm = 4,5 mm
Design thickness due to internal pressure (t)	<u>6.13</u> mm
Governing straight flange design thickness	6,29 mm
Maximum allowable working pressure (MAWP)	<u>40.92</u> bar
Maximum allowable pressure (MAP)	<u>69.64</u> bar
<u>Straight Flange</u> governs MDMT	-46,8°C

Factor K		
	$K = \left(\frac{1}{6}\right) \cdot \left[2 + \left(\frac{D}{2 \cdot h}\right)^2\right]$	
Corroded	$K = \left(\frac{1}{6}\right) \cdot \left[2 + \left(\frac{208,71}{2 \cdot 53,68}\right)^2\right]$	0,9633
New	$K = \left(\frac{1}{6}\right) \cdot \left[2 + \left(\frac{202,71}{2 \cdot 50,68}\right)^2\right]$	1

Design thickness for internal pressure, (Corroded at 175 °C) Appendix 1-4(c)

$$t = \frac{P \cdot D_o \cdot K}{2 \cdot S \cdot E + 2 \cdot P \cdot (K - 0,1)} + \text{Corrosion} = \frac{30,5 \cdot 219,07 \cdot 0,963264}{2 \cdot 1.180 \cdot 0,85 + 2 \cdot 30,5 \cdot (0,963264 - 0,1)} + 3 = 6.13 \text{ mm}$$

Maximum allowable working pressure, (Corroded at 175 °C) Appendix 1-4(c)

$$P = \frac{2 \cdot S \cdot E \cdot t}{K \cdot D_o - 2 \cdot t \cdot (K - 0,1)} - P_s = \frac{2 \cdot 1.180 \cdot 0,85 \cdot (0,875 \cdot 8,18 - 3)}{0,963264 \cdot 219,07 - 2 \cdot (0,875 \cdot 8,18 - 3) \cdot (0,963264 - 0,1)} - 0 = 40.92 \text{ bar}$$

Maximum allowable pressure, (New at 21,11 °C) Appendix 1-4(c)

$$P = \frac{2 \cdot S \cdot E \cdot t}{K \cdot D_o - 2 \cdot t \cdot (K - 0,1)} - P_s = \frac{2 \cdot 1.180 \cdot 0,85 \cdot 0,875 \cdot 8,18}{1 \cdot 219,07 - 2 \cdot 0,875 \cdot 8,18 \cdot (1 - 0,1)} - 0 = 69.64 \text{ bar}$$

ASME Section VIII Division 1 UG-81(a) Out-of-Roundness
Inside surface shall not deviate outside the shape by more than 1,25 % of D
Inside surface shall not deviate inside the shape by more than 0,625 % of D

Straight Flange on B16.9 Pipe Cap - Left Side

ASME Section VIII Division 1, 2021 Edition Metric				
Component		Cylinder		
Material		SA-234 WPB (II-D Metric p. 16, ln. 18)		
Impact Tested	Normalized	Fine Grain Practice	PWHT	Maximize MDMT/ No MAWP
No	No	No	No	No
		Design Pressure (bar)	Design Temperature (°C)	Design MDMT (°C)
Internal		30,5	175	0
Static Liquid Head				
Condition		P_s (bar)	H_s (mm)	SG
Test horizontal		0,03	351,36	1
Dimensions				
Outer Diameter		219,07 mm		
Length		44,17 mm		
Nominal Thickness		8,18 mm		
Corrosion	Inner	3 mm		
	Outer	0 mm		
Weight and Capacity				
		Weight (kg)		Capacity (liters)
New		1,87		1,43
Corroded		1,2		1,51
Radiography				
Longitudinal seam		Seamless No RT		
Right Circumferential seam		Spot UW-11(b) Type 1		

Results Summary	
Governing condition	Internal pressure
Minimum thickness per UG-16	1,5 mm + 3 mm = 4,5 mm
Design thickness due to internal pressure (t)	6.29 mm
Maximum allowable working pressure (MAWP)	48.35 bar
Maximum allowable pressure (MAP)	77.21 bar
Rated MDMT	-46,8 °C

UCS-66 Material Toughness Requirements	
Governing thickness, t _g =	7,16 mm
Exemption temperature from Fig UCS-66M Curve B =	-29°C
$t_r = \frac{38,66 \cdot 109,54}{1,180 \cdot 0,85 + 0,4 \cdot 38,66} =$	4,16 mm
$\text{Stress ratio} = \frac{t_r \cdot E^*}{t_n - c} = \frac{4,16 \cdot 0,85}{8,18 - 3} =$	0,6822
Reduction in MDMT, T _R from Fig UCS-66.1M =	17,8°C
$MDMT = \max [MDMT - T_R, -48] = \max [-29 - 17,8, -48] =$	-46,8°C
Material is exempt from impact testing at the Design MDMT of 0°C.	

Design thickness, (at 175 °C) Appendix 1-1

$$t = \frac{P \cdot R_o}{S \cdot E + 0,40 \cdot P} + \text{Corrosion} = \frac{30,5 \cdot 109,54}{1.180 \cdot 0,85 + 0,40 \cdot 30,5} + 3 = 6,29 \text{ mm}$$

Maximum allowable working pressure, (at 175 °C) Appendix 1-1

$$P = \frac{S \cdot E \cdot t}{R_o - 0,40 \cdot t} - P_s = \frac{1.180 \cdot 0,85 \cdot 5,18}{109,54 - 0,40 \cdot 5,18} - 0 = 48,35 \text{ bar}$$

Maximum allowable pressure, (at 21,11 °C) Appendix 1-1

$$P = \frac{S \cdot E \cdot t}{R_o - 0,40 \cdot t} = \frac{1.180 \cdot 0,85 \cdot 8,18}{109,54 - 0,40 \cdot 8,18} = 77,21 \text{ bar}$$

ASME Section VIII Division 1 UG-80(a) Out-of-Roundness
$(D_{\max} - D_{\min})$ shall not exceed 1% of D
When the cross section passes through an opening or within 1 I.D. of the opening, $(D_{\max} - D_{\min})$ shall not exceed 1% of $D + 2\%$ of the inside diameter of the opening

Air Inlet (N1)

ASME Section VIII Division 1, 2021 Edition Metric

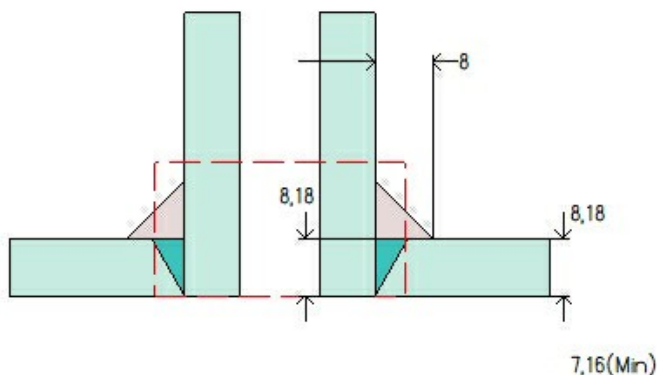

Note: round inside edges per UG-76(c)

Location and Orientation

Located on	B16.9 Pipe Cap - Left Side
Orientation	0°
End of nozzle to datum line	1.036 mm
Calculated as hillside	No
Distance to head center, R	0 mm
Passes through a Category A joint	No

Nozzle

Description	NPS 0,75 XXS DN 20
Access opening	No
Material specification	SA-106 B Smls Pipe (II-D Metric p. 16, In. 16)
Inside diameter, new	11,02 mm
Pipe nominal wall thickness	7,82 mm
Pipe minimum wall thickness ¹	6,85 mm
Corrosion allowance	3 mm
Projection available outside vessel, Lpr	64,43 mm
Local vessel minimum thickness	7,16 mm
Liquid static head included	0 bar

Welds

Inner fillet, Leg ₄₁	8 mm
Nozzle to vessel groove weld	8,18 mm

Radiography

Longitudinal seam	Seamless No RT
Circumferential seam	Full UW-11(a) Type 1

¹Pipe minimum thickness = nominal thickness times pipe tolerance factor of 0,875.

UCS-66 Material Toughness Requirements Nozzle

$t_r = \frac{38,66-8,51}{1.180 \cdot 1 - 0,6 \cdot 38,66} =$	0,28 mm
Stress ratio $= \frac{t_r \cdot E^*}{t_n - c} = \frac{0,28 \cdot 1}{6,85 - 3} =$	0,074
Stress ratio $\leq 0,35$, MDMT per UCS-66(b)(3) =	-105°C
Material is exempt from impact testing at the Design MDMT of 0°C.	

Reinforcement Calculations for Internal Pressure

UG-37 Area Calculation Summary (cm ²)							UG-45 Summary (mm)	
For P = 30,5 bar @ 175 °C							The nozzle passes UG-45	
A required	A available	A ₁	A ₂	A ₃	A ₅	A welds	t _{req}	t _{min}
This nozzle is exempt from area calculations per UG-36(c)(3)(a)							5,51	6,85

UG-41 Weld Failure Path Analysis Summary
The nozzle is exempt from weld strength calculations per UW-15(b)(2)

UW-16 Weld Sizing Summary			
Weld description	Required weld throat size (mm)	Actual weld throat size (mm)	Status
Nozzle to shell fillet (Leg ₄₁)	3,38	5,6	weld size is adequate

Calculations for internal pressure 30,5 bar @ 175 °C

Parallel Limit of reinforcement per UG-40

$$\begin{aligned}
 L_R &= \max [d, R_n + (t_n - C_n) + (t - C)] \\
 &= \max [17,02, 8,51 + (7,82 - 3) + (7,16 - 3)] \\
 &= 17,49 \text{ mm}
 \end{aligned}$$

Outer Normal Limit of reinforcement per UG-40

$$\begin{aligned}
 L_H &= \min [2,5 \cdot (t - C), 2,5 \cdot (t_n - C_n) + t_e] \\
 &= \min [2,5 \cdot (7,16 - 3), 2,5 \cdot (7,82 - 3) + 0] \\
 &= 10,39 \text{ mm}
 \end{aligned}$$

Nozzle required thickness per UG-27(c)(1)

$$\begin{aligned}
 t_{rn} &= \frac{P \cdot R_n}{S_n \cdot E - 0,6 \cdot P} \\
 &= \frac{30,5001 \cdot 8,51}{1,180 \cdot 1 - 0,6 \cdot 30,5001} \\
 &= 0,22 \text{ mm}
 \end{aligned}$$

Required thickness t_r from UG-37(a)(c)

$$\begin{aligned}
 t_r &= \frac{P \cdot K_1 \cdot D_o}{2 \cdot S \cdot E + 0,8 \cdot P} \\
 &= \frac{30,5001 \cdot 0,8749 \cdot 219,07}{2 \cdot 1,180 \cdot 1 + 0,8 \cdot 30,5001} \\
 &= 2,45 \text{ mm}
 \end{aligned}$$

Required thickness t_r per Interpretation VIII-1-07-50

$$t_r = \frac{P \cdot D_o \cdot K}{2 \cdot S \cdot E + 2 \cdot P \cdot (K - 0,1)} = \frac{30,5 \cdot 219,07 \cdot 0,963264}{2 \cdot 1,180 \cdot 0,85 + 2 \cdot 30,5 \cdot (0,963264 - 0,1)} = 3,13 \text{ mm}$$

This opening does not require reinforcement per UG-36(c)(3)(a)

UW-16(c) Weld Check

Fillet weld: $t_{\min} = \min [19\text{mm}, t_n, t] = 4,82 \text{ mm}$

$$t_{c(\min)} = \min [6 \text{ mm}, 0,7 \cdot t_{\min}] = \underline{3,38} \text{ mm}$$

$$t_{c(\text{actual})} = 0,7 \cdot \text{Leg} = 0,7 \cdot 8 = 5,6 \text{ mm}$$

The fillet weld size is satisfactory.

Weld strength calculations are not required for this detail which conforms to Fig. UW-16.1, sketch (c-e).

UG-45 Nozzle Neck Thickness Check

Interpretation VIII-1-83-66 has been applied.

$$\begin{aligned} t_{aUG-27} &= \frac{P \cdot R_n}{S_n \cdot E - 0,6 \cdot P} + \text{Corrosion} \\ &= \frac{30,5001 \cdot 8,51}{1.180 \cdot 1 - 0,6 \cdot 30,5001} + 3 \\ &= 3,22 \text{ mm} \end{aligned}$$

$$\begin{aligned} t_a &= \max [t_{aUG-27}, t_{aUG-22}] \\ &= \max [3,22, 0] \\ &= 3,22 \text{ mm} \end{aligned}$$

$$\begin{aligned} t_{b1} &= \frac{P \cdot D_o \cdot K}{2 \cdot S \cdot E + 2 \cdot P \cdot (K - 0,1)} + \text{Corrosion} \\ &= \frac{30,5 \cdot 219,07 \cdot 0,963264}{2 \cdot 1.180 \cdot 1 + 2 \cdot 30,5 \cdot (0,963264 - 0,1)} + 3 \\ &= 5,67 \text{ mm} \end{aligned}$$

$$\begin{aligned} t_{b1} &= \max [t_{b1}, t_{bUG16}] \\ &= \max [5,67, 4,5] \\ &= 5,67 \text{ mm} \end{aligned}$$

$$\begin{aligned} t_b &= \min [t_{b3}, t_{b1}] \\ &= \min [5,51, 5,67] \\ &= 5,51 \text{ mm} \end{aligned}$$

$$\begin{aligned} t_{UG-45} &= \max [t_a, t_b] \\ &= \max [3,22, 5,51] \\ &= \underline{5,51} \text{ mm} \end{aligned}$$

Available nozzle wall thickness new, $t_n = 0,875 \cdot 7,82 = 6,85 \text{ mm}$

The nozzle neck thickness is adequate.

Reinforcement Calculations for MAWP

The vessel wall thickness governs the MAWP of this nozzle.

UG-37 Area Calculation Summary (cm ²)						UG-45 Summary (mm)		
For P = 52,1 bar @ 175 °C						The nozzle passes UG-45		
A required	A available	A ₁	A ₂	A ₃	A ₅	A welds	t _{req}	t _{min}
This nozzle is exempt from area calculations per UG-36(c)(3)(a)						5,51	6,85	

UG-41 Weld Failure Path Analysis Summary
The nozzle is exempt from weld strength calculations per UW-15(b)(2)

UW-16 Weld Sizing Summary			
Weld description	Required weld throat size (mm)	Actual weld throat size (mm)	Status
Nozzle to shell fillet (Leg ₄₁)	3,38	5,6	weld size is adequate

Calculations for internal pressure 52,1 bar @ 175 °C

Parallel Limit of reinforcement per UG-40

$$\begin{aligned}
 L_R &= \max [d, R_n + (t_n - C_n) + (t - C)] \\
 &= \max [17,02, 8,51 + (7,82 - 3) + (7,16 - 3)] \\
 &= 17,49 \text{ mm}
 \end{aligned}$$

Outer Normal Limit of reinforcement per UG-40

$$\begin{aligned}
 L_H &= \min [2,5 \cdot (t - C), 2,5 \cdot (t_n - C_n) + t_e] \\
 &= \min [2,5 \cdot (7,16 - 3), 2,5 \cdot (7,82 - 3) + 0] \\
 &= 10,39 \text{ mm}
 \end{aligned}$$

Nozzle required thickness per UG-27(c)(1)

$$\begin{aligned}
 t_{rn} &= \frac{P \cdot R_n}{S_n \cdot E - 0,6 \cdot P} \\
 &= \frac{52,1004 \cdot 8,51}{1.180 \cdot 1 - 0,6 \cdot 52,1004} \\
 &= 0,39 \text{ mm}
 \end{aligned}$$

Required thickness t_r from UG-37(a)(c)

$$\begin{aligned}
 t_r &= \frac{P \cdot K_1 \cdot D_o}{2 \cdot S \cdot E + 0,8 \cdot P} \\
 &= \frac{52,1004 \cdot 0,8749 \cdot 219,07}{2 \cdot 1.180 \cdot 1 + 0,8 \cdot 52,1004} \\
 &= 4,16 \text{ mm}
 \end{aligned}$$

Required thickness t_r per Interpretation VIII-1-07-50

$$t_r = \frac{P \cdot D_o \cdot K}{2 \cdot S \cdot E + 2 \cdot P \cdot (K - 0,1)} = \frac{52,1 \cdot 219,07 \cdot 0,963264}{2 \cdot 1.180 \cdot 0,85 + 2 \cdot 52,1 \cdot (0,963264 - 0,1)} = 5,25 \text{ mm}$$

This opening does not require reinforcement per UG-36(c)(3)(a)

UW-16(c) Weld Check

Fillet weld: $t_{\min} = \min [19\text{mm}, t_n, t] = 4,82 \text{ mm}$

$t_{c(\min)} = \min [6 \text{ mm}, 0,7 \cdot t_{\min}] = 3,38 \text{ mm}$

$t_{c(\text{actual})} = 0,7 \cdot \text{Leg} = 0,7 \cdot 8 = 5,6 \text{ mm}$

The fillet weld size is satisfactory.

Weld strength calculations are not required for this detail which conforms to Fig. UW-16.1, sketch (c-e).

UG-45 Nozzle Neck Thickness Check

Interpretation VIII-1-83-66 has been applied.

$$\begin{aligned} t_{aUG-27} &= \frac{P \cdot R_n}{S_n \cdot E - 0,6 \cdot P} + \text{Corrosion} \\ &= \frac{52,1004 \cdot 8,51}{1,180 \cdot 1 - 0,6 \cdot 52,1004} + 3 \\ &= 3,39 \text{ mm} \end{aligned}$$

$$\begin{aligned} t_a &= \max [t_{aUG-27}, t_{aUG-22}] \\ &= \max [3,39, 0] \\ &= 3,39 \text{ mm} \end{aligned}$$

$$\begin{aligned} t_{b1} &= \frac{P \cdot D_o \cdot K}{2 \cdot S \cdot E + 2 \cdot P \cdot (K - 0,1)} + \text{Corrosion} \\ &= \frac{52,1 \cdot 219,07 \cdot 0,963264}{2 \cdot 1,180 \cdot 1 + 2 \cdot 52,1 \cdot (0,963264 - 0,1)} + 3 \\ &= 7,49 \text{ mm} \end{aligned}$$

$$\begin{aligned} t_{b1} &= \max [t_{b1}, t_{bUG16}] \\ &= \max [7,49, 4,5] \\ &= 7,49 \text{ mm} \end{aligned}$$

$$\begin{aligned} t_b &= \min [t_{b3}, t_{b1}] \\ &= \min [5,51, 7,49] \\ &= 5,51 \text{ mm} \end{aligned}$$

$$\begin{aligned} t_{UG-45} &= \max [t_a, t_b] \\ &= \max [3,39, 5,51] \\ &= 5,51 \text{ mm} \end{aligned}$$

Available nozzle wall thickness new, $t_n = 0,875 \cdot 7,82 = 6,85 \text{ mm}$

The nozzle neck thickness is adequate.

Reinforcement Calculations for MAP

The vessel wall thickness governs the MAP of this nozzle.

UG-37 Area Calculation Summary (cm ²)							UG-45 Summary (mm)	
For P = 88,24 bar @ 21,11 °C							The nozzle passes UG-45	
A required	A available	A ₁	A ₂	A ₃	A ₅	A welds	t _{req}	t _{min}
This nozzle is exempt from area calculations per UG-36(c)(3)(a)							2,51	6,85

UG-41 Weld Failure Path Analysis Summary
The nozzle is exempt from weld strength calculations per UW-15(b)(2)

Calculations for internal pressure 88,24 bar @ 21,11 °C

Parallel Limit of reinforcement per UG-40

$$\begin{aligned}
 L_R &= \max [d, R_n + (t_n - C_n) + (t - C)] \\
 &= \max [11,02, 5,51 + (7,82 - 0) + (7,16 - 0)] \\
 &= 20,49 \text{ mm}
 \end{aligned}$$

Outer Normal Limit of reinforcement per UG-40

$$\begin{aligned}
 L_H &= \min [2,5 \cdot (t - C), 2,5 \cdot (t_n - C_n) + t_e] \\
 &= \min [2,5 \cdot (7,16 - 0), 2,5 \cdot (7,82 - 0) + 0] \\
 &= 17,89 \text{ mm}
 \end{aligned}$$

Nozzle required thickness per UG-27(c)(1)

$$\begin{aligned}
 t_{rn} &= \frac{P \cdot R_n}{S_n \cdot E - 0,6 \cdot P} \\
 &= \frac{88,2375 \cdot 5,51}{1,180 \cdot 1 - 0,6 \cdot 88,2375} \\
 &= 0,43 \text{ mm}
 \end{aligned}$$

Required thickness t_r from UG-37(a)(c)

$$\begin{aligned}
 t_r &= \frac{P \cdot K_1 \cdot D_o}{2 \cdot S \cdot E + 0,8 \cdot P} \\
 &= \frac{88,2375 \cdot 0,9 \cdot 219,07}{2 \cdot 1,180 \cdot 1 + 0,8 \cdot 88,2375} \\
 &= 7,16 \text{ mm}
 \end{aligned}$$

Required thickness t_r per Interpretation VIII-1-07-50

$$t_r = \frac{P \cdot D_o \cdot K}{2 \cdot S \cdot E + 2 \cdot P \cdot (K - 0,1)} = \frac{88,24 \cdot 219,07 \cdot 1}{2 \cdot 1,180 \cdot 0,85 + 2 \cdot 88,24 \cdot (1 - 0,1)} = 8,93 \text{ mm}$$

This opening does not require reinforcement per UG-36(c)(3)(a)

UG-45 Nozzle Neck Thickness Check

Interpretation VIII-1-83-66 has been applied.

$$\begin{aligned}t_{aUG-27} &= \frac{P \cdot R_n}{S_n \cdot E - 0,6 \cdot P} + \text{Corrosion} \\ &= \frac{88,2375 \cdot 5,51}{1.180 \cdot 1 - 0,6 \cdot 88,2375} + 0 \\ &= 0,43 \text{ mm}\end{aligned}$$

$$\begin{aligned}t_a &= \max [t_{aUG-27}, t_{aUG-22}] \\ &= \max [0,43, 0] \\ &= 0,43 \text{ mm}\end{aligned}$$

$$\begin{aligned}t_{b1} &= \frac{P \cdot D_o \cdot K}{2 \cdot S \cdot E + 2 \cdot P \cdot (K - 0,1)} + \text{Corrosion} \\ &= \frac{88,24 \cdot 219,07 \cdot 1}{2 \cdot 1.180 \cdot 1 + 2 \cdot 88,24 \cdot (1 - 0,1)} + 0 \\ &= 7,67 \text{ mm}\end{aligned}$$

$$\begin{aligned}t_{b1} &= \max [t_{b1}, t_{bUG16}] \\ &= \max [7,67, 1,5] \\ &= 7,67 \text{ mm}\end{aligned}$$

$$\begin{aligned}t_b &= \min [t_{b3}, t_{b1}] \\ &= \min [2,51, 7,67] \\ &= 2,51 \text{ mm}\end{aligned}$$

$$\begin{aligned}t_{UG-45} &= \max [t_a, t_b] \\ &= \max [0,43, 2,51] \\ &= 2,51 \text{ mm}\end{aligned}$$

Available nozzle wall thickness new, $t_n = 0,875 \cdot 7,82 = 6,85 \text{ mm}$

The nozzle neck thickness is adequate.

B16.9 Elbow #1 (N1)

ASME Section VIII Division 1, 2021 Edition Metric				
Component		ASME B16.9 Elbow		
Type		Long Radius 90-deg		
Material		SA-234 WPB (II-D Metric p. 16, ln. 18)		
Pipe NPS and Schedule		NPS 0,75 XXS DN 20		
Attached To		Air Inlet (N1)		
Impact Tested	Normalized	Fine Grain Practice	PWHT	Maximize MDMT/ No MAWP
No	No	No	No	No
		Design Pressure (bar)	Design Temperature (°C)	Design MDMT (°C)
Internal		30,5	175	0
Static Liquid Head				
Condition		P_s (bar)	H_s (mm)	SG
Test horizontal		0,03	255,51	1
Dimensions				
Outer Diameter		26,67 mm		
Nominal Thickness		7,82 mm		
Minimum Thickness¹		6,85 mm		
Center-to-End, A		38 mm		
Corrosion	Inner	3 mm		
	Outer	0 mm		
Weight and Capacity				
		Weight (kg)	Capacity (liters)	
New		0,22	0,01	
Corroded		0,16	0,01	
Radiography				
Longitudinal seam		Seamless No RT		
Left Circumferential seam		Full UW-11(a) Type 1		
Right Circumferential seam		Full UW-11(a) Type 1		

¹ minimum thickness = nominal thickness times pipe tolerance factor of 0,875.

ASME B16.5-2017 Flange	
Description	NPS 0,75 Class 600 WN A105
Bolt Material	SA-193 B7 Bolt <= 64 (II-D Metric p. 410, In. 32)
Blind included	No
Rated MDMT	-48°C
Liquid static head	0 bar
MAWP rating	88,9 bar @ 175°C
MAP rating	102,1 bar @ 21,11°C
Hydrotest rating	154 bar @ 21,11°C
PWHT performed	No
Produced to Fine Grain Practice and Supplied in Heat Treated Condition	No
Impact Tested	No
Circumferential joint radiography	Full UW-11(a) Type 1
Bore diameter, B (specified by purchaser)	11,02 mm
Gasket	
Type	ASME B16.20 Spiral-Wound
Description	Garlock FLEXSEAL RW 316L SS / Flexible Graphite
Factor, m	3
Seating Stress, y	703,07 kgf/cm ²
Thickness, T	3 mm
Inner Diameter	25,4 mm
Outer Diameter	39,6 mm
Notes	
Flange rated MDMT per UCS-66(b)(1)(b) = -48°C (Coincident ratio = 0,3786) Bolts rated MDMT per Fig UCS-66 note (c) = -48°C	

Results Summary	
Governing condition	UG-16
Minimum thickness per UG-16	1,5 mm + 3 mm = 4,5 mm
Design thickness due to internal pressure (t)	3.34 mm
Maximum allowable working pressure (MAWP)	401.45 bar
Maximum allowable pressure (MAP)	849.81 bar
Rated MDMT	-105 °C

UCS-66 Material Toughness Requirements	
$t_r = 13,34 \cdot \left(1 - \exp\left(-\frac{38,66}{1.180 \cdot 1} \right) \right) =$	0,43 mm
Stress ratio = $\frac{t_r \cdot E^*}{t_n - c} = \frac{0,43 \cdot 1}{6,85 - 3} =$	0,1118
Stress ratio $\leq 0,35$, MDMT per UCS-66(b)(3) =	-105°C
Material is exempt from impact testing at the Design MDMT of 0°C.	

Design thickness, (at 175 °C) Appendix 1-2

$$t = R_o \cdot \left(1 - \exp\left[-\frac{P}{S \cdot E} \right] \right) + \text{Corrosion} = 13,34 \cdot \left(1 - \exp\left[-\frac{30,5}{1.180 \cdot 1,00} \right] \right) + 3 = \text{3.34 mm}$$

Maximum allowable working pressure, (at 175 °C) Appendix 1-2

$$P = S \cdot E \cdot \ln\left(\frac{R_o}{R_o - t}\right) - P_s = 1.180 \cdot 1,00 \cdot \ln\left(\frac{13,34}{13,34 - (7,82 \cdot 0,875 - 3)}\right) - 0 = \underline{401,45} \text{ bar}$$

Maximum allowable pressure, (at 21,11 °C) Appendix 1-2

$$P = S \cdot E \cdot \ln\left(\frac{R_o}{R_o - t}\right) = 1.180 \cdot 1,00 \cdot \ln\left(\frac{13,34}{13,34 - (7,82 \cdot 0,875)}\right) = \underline{849,81} \text{ bar}$$

Cylinder #1

ASME Section VIII Division 1, 2021 Edition Metric				
Component		Cylinder		
Material		SA-106 B Smls Pipe (II-D Metric p. 16, ln. 16)		
Pipe NPS and Schedule		NPS 8 Sch 40 (Std) DN 200		
Impact Tested	Normalized	Fine Grain Practice	PWHT	Maximize MDMT/ No MAWP
No	No	No	No	No
		Design Pressure (bar)	Design Temperature (°C)	Design MDMT (°C)
Internal		30,5	175	0
Static Liquid Head				
Condition		P_s (bar)	H_s (mm)	SG
Test horizontal		0,03	351,36	1
Dimensions				
Outer Diameter		219,07 mm		
Length		870 mm		
Pipe Nominal Thickness		8,18 mm		
Pipe Minimum Thickness¹		7,16 mm		
Corrosion	Inner	3 mm		
	Outer	0 mm		
Weight and Capacity				
		Weight (kg)	Capacity (liters)	
New		36,57	28,08	
Corroded		23,49	29,76	
Radiography				
Longitudinal seam		Seamless No RT		
Left Circumferential seam		Spot UW-11(b) Type 1		
Right Circumferential seam		Spot UW-11(b) Type 1		

¹Pipe minimum thickness = nominal thickness times pipe tolerance factor of 0,875.

Results Summary	
Governing condition	Internal pressure
Minimum thickness per UG-16	1,5 mm + 3 mm = 4,5 mm
Design thickness due to internal pressure (t)	6.29 mm
Maximum allowable working pressure (MAWP)	38.66 bar
Maximum allowable pressure (MAP)	67.3 bar
Rated MDMT	-37,4 °C

UCS-66 Material Toughness Requirements	
Governing thickness, t _g =	7,16 mm
Exemption temperature from Fig UCS-66M Curve B =	-29°C
$t_r = \frac{38,66 \cdot 109,54}{1.180 \cdot 0,85 + 0,4 \cdot 38,66} =$	4,16 mm
$\text{Stress ratio} = \frac{t_r \cdot E^*}{t_n - c} = \frac{4,16 \cdot 0,85}{7,16 - 3} =$	0,85
Reduction in MDMT, T _R from Fig UCS-66.1M =	8,4°C
$MDMT = \max [MDMT - T_R, -48] = \max [-29 - 8,4, -48] =$	-37,4°C
Material is exempt from impact testing at the Design MDMT of 0°C.	

Design thickness, (at 175 °C) Appendix 1-1

$$t = \frac{P \cdot R_o}{S \cdot E + 0,40 \cdot P} + \text{Corrosion} = \frac{30,5 \cdot 109,54}{1.180 \cdot 0,85 + 0,40 \cdot 30,5} + 3 = \underline{6,29} \text{ mm}$$

Maximum allowable working pressure, (at 175 °C) Appendix 1-1

$$P = \frac{S \cdot E \cdot t}{R_o - 0,40 \cdot t} - P_s = \frac{1.180 \cdot 0,85 \cdot (8,18 \cdot 0,875 - 3)}{109,54 - 0,40 \cdot (8,18 \cdot 0,875 - 3)} - 0 = \underline{38,66} \text{ bar}$$

Maximum allowable pressure, (at 21,11 °C) Appendix 1-1

$$P = \frac{S \cdot E \cdot t}{R_o - 0,40 \cdot t} = \frac{1.180 \cdot 0,85 \cdot (8,18 \cdot 0,875)}{109,54 - 0,40 \cdot (8,18 \cdot 0,875)} = \underline{67,3} \text{ bar}$$

Temperature Gauge Connection (N3)

ASME Section VIII Division 1, 2021 Edition Metric

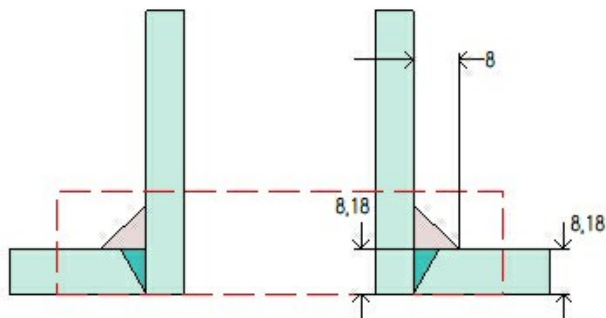

Note: round inside edges per UG-76(c)

Location and Orientation

Located on	Cylinder #1
Orientation	0°
Nozzle center line offset to datum line	525 mm
End of nozzle to shell center	250 mm
Passes through a Category A joint	No

Nozzle

Description	NPS 1,5 Sch 160 DN 40
Access opening	No
Material specification	SA-106 B Smls Pipe (II-D Metric p. 16, In. 16)
Inside diameter, new	33,99 mm
Pipe nominal wall thickness	7,14 mm
Pipe minimum wall thickness ¹	6,25 mm
Corrosion allowance	3 mm
Projection available outside vessel, Lpr	64,27 mm
Projection available outside vessel to flange face, Lf	140,47 mm
Local vessel minimum thickness	7,16 mm
Liquid static head included	0 bar

Welds

Inner fillet, Leg ₄₁	8 mm
Nozzle to vessel groove weld	8,18 mm

Radiography

Longitudinal seam	Seamless No RT
Circumferential seam	Full UW-11(a) Type 1

¹Pipe minimum thickness = nominal thickness times pipe tolerance factor of 0,875.

ASME B16.5-2017 Flange	
Description	NPS 1,5 Class 600 WN A105
Bolt Material	SA-193 B7 Bolt <= 64 (II-D Metric p. 410, In. 32)
Blind included	No
Rated MDMT	-48°C
Liquid static head	0 bar
MAWP rating	88,9 bar @ 175°C
MAP rating	102,1 bar @ 21,11°C
Hydrotest rating	154 bar @ 21,11°C
PWHT performed	No
Produced to Fine Grain Practice and Supplied in Heat Treated Condition	No
Impact Tested	No
Circumferential joint radiography	Full UW-11(a) Type 1
Bore diameter, B (specified by purchaser)	40,89 mm
Gasket	
Type	ASME B16.20 Spiral-Wound
Description	Garlock FLEXSEAL RW 316L SS / Flexible Graphite
Factor, m	3
Seating Stress, y	703,07 kgf/cm ²
Thickness, T	3 mm
Inner Diameter	54,1 mm
Outer Diameter	69,9 mm
Notes	
Flange rated MDMT per UCS-66(b)(1)(b) = -48°C (Coincident ratio = 0,3786) Bolts rated MDMT per Fig UCS-66 note (c) = -48°C	

UCS-66 Material Toughness Requirements Nozzle	
$t_r = \frac{38,66 \cdot 19,99}{1,180 \cdot 1 - 0,6 \cdot 38,66} =$	0,67 mm
Stress ratio = $\frac{t_r \cdot E^*}{t_n - c} = \frac{0,67 \cdot 1}{6,25 - 3} =$	0,2059
Stress ratio ≤ 0,35, MDMT per UCS-66(b)(3) =	-105°C
Material is exempt from impact testing at the Design MDMT of 0°C.	

Reinforcement Calculations for Internal Pressure

UG-37 Area Calculation Summary (cm ²)							UG-45 Summary (mm)	
For P = 30,5 bar @ 175 °C							The nozzle passes UG-45	
A required	A available	A ₁	A ₂	A ₃	A ₅	A welds	t _{req}	t _{min}
This nozzle is exempt from area calculations per UG-36(c)(3)(a)							5,8	6,25

UG-41 Weld Failure Path Analysis Summary
The nozzle is exempt from weld strength calculations per UW-15(b)(2)

UW-16 Weld Sizing Summary			
Weld description	Required weld throat size (mm)	Actual weld throat size (mm)	Status
Nozzle to shell fillet (Leg ₄₁)	2,9	5,6	weld size is adequate

Calculations for internal pressure 30,5 bar @ 175 °C

Parallel Limit of reinforcement per UG-40

$$\begin{aligned}
 L_R &= \max [d, R_n + (t_n - C_n) + (t - C)] \\
 &= \max [39,99, 19,99 + (7,14 - 3) + (7,16 - 3)] \\
 &= 39,99 \text{ mm}
 \end{aligned}$$

Outer Normal Limit of reinforcement per UG-40

$$\begin{aligned}
 L_H &= \min [2,5 \cdot (t - C), 2,5 \cdot (t_n - C_n) + t_e] \\
 &= \min [2,5 \cdot (7,16 - 3), 2,5 \cdot (7,14 - 3) + 0] \\
 &= 10,34 \text{ mm}
 \end{aligned}$$

Nozzle required thickness per UG-27(c)(1)

$$\begin{aligned}
 t_{rn} &= \frac{P \cdot R_n}{S_n \cdot E - 0,6 \cdot P} \\
 &= \frac{30,5001 \cdot 19,99}{1,180 \cdot 1 - 0,6 \cdot 30,5001} \\
 &= 0,53 \text{ mm}
 \end{aligned}$$

Required thickness t_r from UG-37(a)

$$\begin{aligned}
 t_r &= \frac{P \cdot R_o}{S \cdot E + 0,4 \cdot P} \\
 &= \frac{30,5001 \cdot 109,54}{1,180 \cdot 1 + 0,4 \cdot 30,5001} \\
 &= 2,8 \text{ mm}
 \end{aligned}$$

Required thickness t_r per Interpretation VIII-1-07-50

$$\begin{aligned}
t_r &= \frac{P \cdot R_o}{S \cdot E + 0,4 \cdot P} \\
&= \frac{30,5001 \cdot 109,54}{1.180 \cdot 0,85 + 0,4 \cdot 30,5001} \\
&= 3,29 \text{ mm}
\end{aligned}$$

This opening does not require reinforcement per UG-36(c)(3)(a)

UW-16(c) Weld Check

Fillet weld: $t_{\min} = \min [19\text{mm}, t_n, t] = 4,14 \text{ mm}$

$$t_{c(\min)} = \min [6 \text{ mm}, 0,7 \cdot t_{\min}] = 2,9 \text{ mm}$$

$$t_{c(\text{actual})} = 0,7 \cdot \text{Leg} = 0,7 \cdot 8 = 5,6 \text{ mm}$$

The fillet weld size is satisfactory.

Weld strength calculations are not required for this detail which conforms to Fig. UW-16.1, sketch (c-e).

UG-45 Nozzle Neck Thickness Check

$$\begin{aligned}
t_{aUG-27} &= \frac{P \cdot R_n}{S_n \cdot E - 0,6 \cdot P} + \text{Corrosion} \\
&= \frac{30,5001 \cdot 19,99}{1.180 \cdot 1 - 0,6 \cdot 30,5001} + 3 \\
&= 3,53 \text{ mm}
\end{aligned}$$

$$\begin{aligned}
t_a &= \max [t_{aUG-27}, t_{aUG-22}] \\
&= \max [3,53, 0] \\
&= 3,53 \text{ mm}
\end{aligned}$$

$$\begin{aligned}
t_{b1} &= \frac{P \cdot R_o}{S \cdot E + 0,4 \cdot P} + \text{Corrosion} \\
&= \frac{30,5001 \cdot 109,54}{1.180 \cdot 1 + 0,4 \cdot 30,5001} + 3 \\
&= 5,8 \text{ mm}
\end{aligned}$$

$$\begin{aligned}
t_{b1} &= \max [t_{b1}, t_{bUG16}] \\
&= \max [5,8, 4,5] \\
&= 5,8 \text{ mm}
\end{aligned}$$

$$\begin{aligned}
t_b &= \min [t_{b3}, t_{b1}] \\
&= \min [6,22, 5,8] \\
&= 5,8 \text{ mm}
\end{aligned}$$

$$\begin{aligned}
t_{UG-45} &= \max [t_a, t_b] \\
&= \max [3,53, 5,8] \\
&= 5,8 \text{ mm}
\end{aligned}$$

Available nozzle wall thickness new, $t_n = 0,875 \cdot 7,14 = 6,25$ mm

The nozzle neck thickness is adequate.

Reinforcement Calculations for MAWP

The vessel wall thickness governs the MAWP of this nozzle.

UG-37 Area Calculation Summary (cm ²)						UG-45 Summary (mm)		
For P = 45,48 bar @ 175 °C						The nozzle passes UG-45		
A required	A available	A ₁	A ₂	A ₃	A ₅	A welds	t _{req}	t _{min}
This nozzle is exempt from area calculations per UG-36(c)(3)(a)						6,22	6,25	

UG-41 Weld Failure Path Analysis Summary
The nozzle is exempt from weld strength calculations per UW-15(b)(2)

UW-16 Weld Sizing Summary			
Weld description	Required weld throat size (mm)	Actual weld throat size (mm)	Status
Nozzle to shell fillet (Leg ₄₁)	2,9	5,6	weld size is adequate

Calculations for internal pressure 45,48 bar @ 175 °C

Parallel Limit of reinforcement per UG-40

$$\begin{aligned}
 L_R &= \max [d, R_n + (t_n - C_n) + (t - C)] \\
 &= \max [39,99, 19,99 + (7,14 - 3) + (7,16 - 3)] \\
 &= 39,99 \text{ mm}
 \end{aligned}$$

Outer Normal Limit of reinforcement per UG-40

$$\begin{aligned}
 L_H &= \min [2,5 \cdot (t - C), 2,5 \cdot (t_n - C_n) + t_e] \\
 &= \min [2,5 \cdot (7,16 - 3), 2,5 \cdot (7,14 - 3) + 0] \\
 &= 10,34 \text{ mm}
 \end{aligned}$$

Nozzle required thickness per UG-27(c)(1)

$$\begin{aligned}
 t_{rn} &= \frac{P \cdot R_n}{S_n \cdot E - 0,6 \cdot P} \\
 &= \frac{45,4848 \cdot 19,99}{1,180 \cdot 1 - 0,6 \cdot 45,4848} \\
 &= 0,79 \text{ mm}
 \end{aligned}$$

Required thickness t_r from UG-37(a)

$$\begin{aligned}
 t_r &= \frac{P \cdot R_o}{S \cdot E + 0,4 \cdot P} \\
 &= \frac{45,4848 \cdot 109,54}{1,180 \cdot 1 + 0,4 \cdot 45,4848} \\
 &= 4,16 \text{ mm}
 \end{aligned}$$

Required thickness t_r per Interpretation VIII-1-07-50

$$\begin{aligned}
t_r &= \frac{P \cdot R_o}{S \cdot E + 0,4 \cdot P} \\
&= \frac{45,4848 \cdot 109,54}{1.180 \cdot 0,85 + 0,4 \cdot 45,4848} \\
&= 4,88 \text{ mm}
\end{aligned}$$

This opening does not require reinforcement per UG-36(c)(3)(a)

UW-16(c) Weld Check

Fillet weld: $t_{\min} = \min [19\text{mm}, t_n, t] = 4,14 \text{ mm}$

$t_{c(\min)} = \min [6 \text{ mm}, 0,7 \cdot t_{\min}] = 2,9 \text{ mm}$

$t_{c(\text{actual})} = 0,7 \cdot \text{Leg} = 0,7 \cdot 8 = 5,6 \text{ mm}$

The fillet weld size is satisfactory.

Weld strength calculations are not required for this detail which conforms to Fig. UW-16.1, sketch (c-e).

UG-45 Nozzle Neck Thickness Check

$$\begin{aligned}
t_{aUG-27} &= \frac{P \cdot R_n}{S_n \cdot E - 0,6 \cdot P} + \text{Corrosion} \\
&= \frac{45,4848 \cdot 19,99}{1.180 \cdot 1 - 0,6 \cdot 45,4848} + 3 \\
&= 3,79 \text{ mm}
\end{aligned}$$

$$\begin{aligned}
t_a &= \max [t_{aUG-27}, t_{aUG-22}] \\
&= \max [3,79, 0] \\
&= 3,79 \text{ mm}
\end{aligned}$$

$$\begin{aligned}
t_{b1} &= \frac{P \cdot R_o}{S \cdot E + 0,4 \cdot P} + \text{Corrosion} \\
&= \frac{45,4848 \cdot 109,54}{1.180 \cdot 1 + 0,4 \cdot 45,4848} + 3 \\
&= 7,16 \text{ mm}
\end{aligned}$$

$$\begin{aligned}
t_{b1} &= \max [t_{b1}, t_{bUG16}] \\
&= \max [7,16, 4,5] \\
&= 7,16 \text{ mm}
\end{aligned}$$

$$\begin{aligned}
t_b &= \min [t_{b3}, t_{b1}] \\
&= \min [6,22, 7,16] \\
&= 6,22 \text{ mm}
\end{aligned}$$

$$\begin{aligned}
t_{UG-45} &= \max [t_a, t_b] \\
&= \max [3,79, 6,22] \\
&= 6,22 \text{ mm}
\end{aligned}$$

Available nozzle wall thickness new, $t_n = 0,875 \cdot 7,14 = 6,25$ mm

The nozzle neck thickness is adequate.

Reinforcement Calculations for MAP

The vessel wall thickness governs the MAP of this nozzle.

UG-37 Area Calculation Summary (cm ²)							UG-45 Summary (mm)	
For P = 79,18 bar @ 21,11 °C							The nozzle passes UG-45	
A required	A available	A ₁	A ₂	A ₃	A ₅	A welds	t _{req}	t _{min}
This nozzle is exempt from area calculations per UG-36(c)(3)(a)							3,22	6,25

UG-41 Weld Failure Path Analysis Summary
The nozzle is exempt from weld strength calculations per UW-15(b)(2)

Calculations for internal pressure 79,18 bar @ 21,11 °C

Parallel Limit of reinforcement per UG-40

$$\begin{aligned}
 L_R &= \max [d, R_n + (t_n - C_n) + (t - C)] \\
 &= \max [33,99, 16,99 + (7,14 - 0) + (7,16 - 0)] \\
 &= 33,99 \text{ mm}
 \end{aligned}$$

Outer Normal Limit of reinforcement per UG-40

$$\begin{aligned}
 L_H &= \min [2,5 \cdot (t - C), 2,5 \cdot (t_n - C_n) + t_e] \\
 &= \min [2,5 \cdot (7,16 - 0), 2,5 \cdot (7,14 - 0) + 0] \\
 &= 17,84 \text{ mm}
 \end{aligned}$$

Nozzle required thickness per UG-27(c)(1)

$$\begin{aligned}
 t_{rn} &= \frac{P \cdot R_n}{S_n \cdot E - 0,6 \cdot P} \\
 &= \frac{79,1796 \cdot 16,99}{1,180 \cdot 1 - 0,6 \cdot 79,1796} \\
 &= 1,19 \text{ mm}
 \end{aligned}$$

Required thickness t_r from UG-37(a)

$$\begin{aligned}
 t_r &= \frac{P \cdot R_o}{S \cdot E + 0,4 \cdot P} \\
 &= \frac{79,1796 \cdot 109,54}{1,180 \cdot 1 + 0,4 \cdot 79,1796} \\
 &= 7,16 \text{ mm}
 \end{aligned}$$

Required thickness t_r per Interpretation VIII-1-07-50

$$\begin{aligned}
 t_r &= \frac{P \cdot R_o}{S \cdot E + 0,4 \cdot P} \\
 &= \frac{79,1796 \cdot 109,54}{1,180 \cdot 0,85 + 0,4 \cdot 79,1796} \\
 &= 8,38 \text{ mm}
 \end{aligned}$$

This opening does not require reinforcement per UG-36(c)(3)(a)

UG-45 Nozzle Neck Thickness Check

$$\begin{aligned}t_{aUG-27} &= \frac{P \cdot R_n}{S_n \cdot E - 0,6 \cdot P} + \text{Corrosion} \\ &= \frac{79,1796 \cdot 16,99}{1.180 \cdot 1 - 0,6 \cdot 79,1796} + 0 \\ &= 1,19 \text{ mm}\end{aligned}$$

$$\begin{aligned}t_a &= \max [t_{aUG-27}, t_{aUG-22}] \\ &= \max [1,19, 0] \\ &= 1,19 \text{ mm}\end{aligned}$$

$$\begin{aligned}t_{b1} &= \frac{P \cdot R_o}{S \cdot E + 0,4 \cdot P} + \text{Corrosion} \\ &= \frac{79,1796 \cdot 109,54}{1.180 \cdot 1 + 0,4 \cdot 79,1796} + 0 \\ &= 7,16 \text{ mm}\end{aligned}$$

$$\begin{aligned}t_{b1} &= \max [t_{b1}, t_{bUG16}] \\ &= \max [7,16, 1,5] \\ &= 7,16 \text{ mm}\end{aligned}$$

$$\begin{aligned}t_b &= \min [t_{b3}, t_{b1}] \\ &= \min [3,22, 7,16] \\ &= 3,22 \text{ mm}\end{aligned}$$

$$\begin{aligned}t_{UG-45} &= \max [t_a, t_b] \\ &= \max [1,19, 3,22] \\ &= \underline{3,22} \text{ mm}\end{aligned}$$

Available nozzle wall thickness new, $t_n = 0,875 \cdot 7,14 = 6,25 \text{ mm}$

The nozzle neck thickness is adequate.

Temperature Transmitter Connection (N4)

ASME Section VIII Division 1, 2021 Edition Metric

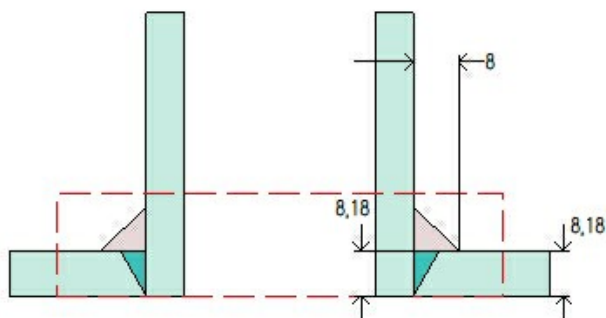

Note: round inside edges per UG-76(c)

Location and Orientation

Located on	Cylinder #1
Orientation	90°
Nozzle center line offset to datum line	125 mm
End of nozzle to shell center	250 mm
Passes through a Category A joint	No

Nozzle

Description	NPS 1,5 Sch 160 DN 40
Access opening	No
Material specification	SA-106 B Smls Pipe (II-D Metric p. 16, In. 16)
Inside diameter, new	33,99 mm
Pipe nominal wall thickness	7,14 mm
Pipe minimum wall thickness ¹	6,25 mm
Corrosion allowance	3 mm
Projection available outside vessel, L _{pr}	64,27 mm
Projection available outside vessel to flange face, L _f	140,47 mm
Local vessel minimum thickness	7,16 mm
Liquid static head included	0 bar

Welds

Inner fillet, Leg ₄₁	8 mm
Nozzle to vessel groove weld	8,18 mm

Radiography

Longitudinal seam	Seamless No RT
Circumferential seam	Full UW-11(a) Type 1

¹Pipe minimum thickness = nominal thickness times pipe tolerance factor of 0,875.

ASME B16.5-2017 Flange	
Description	NPS 1,5 Class 600 WN A105
Bolt Material	SA-193 B7 Bolt <= 64 (II-D Metric p. 410, In. 32)
Blind included	No
Rated MDMT	-48°C
Liquid static head	0 bar
MAWP rating	88,9 bar @ 175°C
MAP rating	102,1 bar @ 21,11°C
Hydrotest rating	154 bar @ 21,11°C
PWHT performed	No
Produced to Fine Grain Practice and Supplied in Heat Treated Condition	No
Impact Tested	No
Circumferential joint radiography	Full UW-11(a) Type 1
Bore diameter, B (specified by purchaser)	40,89 mm
Gasket	
Type	ASME B16.20 Spiral-Wound
Description	Garlock FLEXSEAL RW 316L SS / Flexible Graphite
Factor, m	3
Seating Stress, y	703,07 kgf/cm ²
Thickness, T	3 mm
Inner Diameter	54,1 mm
Outer Diameter	69,9 mm
Notes	
Flange rated MDMT per UCS-66(b)(1)(b) = -48°C (Coincident ratio = 0,3786) Bolts rated MDMT per Fig UCS-66 note (c) = -48°C	

UCS-66 Material Toughness Requirements Nozzle	
$t_r = \frac{38,66 \cdot 19,99}{1,180 \cdot 1 - 0,6 \cdot 38,66} =$	0,67 mm
Stress ratio = $\frac{t_r \cdot E^*}{t_n - c} = \frac{0,67 \cdot 1}{6,25 - 3} =$	0,2059
Stress ratio ≤ 0,35, MDMT per UCS-66(b)(3) =	-105°C
Material is exempt from impact testing at the Design MDMT of 0°C.	

Reinforcement Calculations for Internal Pressure

UG-37 Area Calculation Summary (cm ²)							UG-45 Summary (mm)	
For P = 30,5 bar @ 175 °C							The nozzle passes UG-45	
A required	A available	A ₁	A ₂	A ₃	A ₅	A welds	t _{req}	t _{min}
This nozzle is exempt from area calculations per UG-36(c)(3)(a)							5,8	6,25

UG-41 Weld Failure Path Analysis Summary
The nozzle is exempt from weld strength calculations per UW-15(b)(2)

UW-16 Weld Sizing Summary			
Weld description	Required weld throat size (mm)	Actual weld throat size (mm)	Status
Nozzle to shell fillet (Leg ₄₁)	2,9	5,6	weld size is adequate

Calculations for internal pressure 30,5 bar @ 175 °C

Parallel Limit of reinforcement per UG-40

$$\begin{aligned}
 L_R &= \max [d, R_n + (t_n - C_n) + (t - C)] \\
 &= \max [39,99, 19,99 + (7,14 - 3) + (7,16 - 3)] \\
 &= 39,99 \text{ mm}
 \end{aligned}$$

Outer Normal Limit of reinforcement per UG-40

$$\begin{aligned}
 L_H &= \min [2,5 \cdot (t - C), 2,5 \cdot (t_n - C_n) + t_e] \\
 &= \min [2,5 \cdot (7,16 - 3), 2,5 \cdot (7,14 - 3) + 0] \\
 &= 10,34 \text{ mm}
 \end{aligned}$$

Nozzle required thickness per UG-27(c)(1)

$$\begin{aligned}
 t_{rn} &= \frac{P \cdot R_n}{S_n \cdot E - 0,6 \cdot P} \\
 &= \frac{30,5001 \cdot 19,99}{1,180 \cdot 1 - 0,6 \cdot 30,5001} \\
 &= 0,53 \text{ mm}
 \end{aligned}$$

Required thickness t_r from UG-37(a)

$$\begin{aligned}
 t_r &= \frac{P \cdot R_o}{S \cdot E + 0,4 \cdot P} \\
 &= \frac{30,5001 \cdot 109,54}{1,180 \cdot 1 + 0,4 \cdot 30,5001} \\
 &= 2,8 \text{ mm}
 \end{aligned}$$

Required thickness t_r per Interpretation VIII-1-07-50

$$\begin{aligned}
t_r &= \frac{P \cdot R_o}{S \cdot E + 0,4 \cdot P} \\
&= \frac{30,5001 \cdot 109,54}{1.180 \cdot 0,85 + 0,4 \cdot 30,5001} \\
&= 3,29 \text{ mm}
\end{aligned}$$

This opening does not require reinforcement per UG-36(c)(3)(a)

UW-16(c) Weld Check

Fillet weld: $t_{\min} = \min [19\text{mm}, t_n, t] = 4,14 \text{ mm}$

$$t_{c(\min)} = \min [6 \text{ mm}, 0,7 \cdot t_{\min}] = 2,9 \text{ mm}$$

$$t_{c(\text{actual})} = 0,7 \cdot \text{Leg} = 0,7 \cdot 8 = 5,6 \text{ mm}$$

The fillet weld size is satisfactory.

Weld strength calculations are not required for this detail which conforms to Fig. UW-16.1, sketch (c-e).

UG-45 Nozzle Neck Thickness Check

$$\begin{aligned}
t_{aUG-27} &= \frac{P \cdot R_n}{S_n \cdot E - 0,6 \cdot P} + \text{Corrosion} \\
&= \frac{30,5001 \cdot 19,99}{1.180 \cdot 1 - 0,6 \cdot 30,5001} + 3 \\
&= 3,53 \text{ mm}
\end{aligned}$$

$$\begin{aligned}
t_a &= \max [t_{aUG-27}, t_{aUG-22}] \\
&= \max [3,53, 0] \\
&= 3,53 \text{ mm}
\end{aligned}$$

$$\begin{aligned}
t_{b1} &= \frac{P \cdot R_o}{S \cdot E + 0,4 \cdot P} + \text{Corrosion} \\
&= \frac{30,5001 \cdot 109,54}{1.180 \cdot 1 + 0,4 \cdot 30,5001} + 3 \\
&= 5,8 \text{ mm}
\end{aligned}$$

$$\begin{aligned}
t_{b1} &= \max [t_{b1}, t_{bUG16}] \\
&= \max [5,8, 4,5] \\
&= 5,8 \text{ mm}
\end{aligned}$$

$$\begin{aligned}
t_b &= \min [t_{b3}, t_{b1}] \\
&= \min [6,22, 5,8] \\
&= 5,8 \text{ mm}
\end{aligned}$$

$$\begin{aligned}
t_{UG-45} &= \max [t_a, t_b] \\
&= \max [3,53, 5,8] \\
&= 5,8 \text{ mm}
\end{aligned}$$

Available nozzle wall thickness new, $t_n = 0,875 \cdot 7,14 = 6,25$ mm

The nozzle neck thickness is adequate.

Reinforcement Calculations for MAWP

The vessel wall thickness governs the MAWP of this nozzle.

UG-37 Area Calculation Summary (cm ²)						UG-45 Summary (mm)		
For P = 45,48 bar @ 175 °C						The nozzle passes UG-45		
A required	A available	A ₁	A ₂	A ₃	A ₅	A welds	t _{req}	t _{min}
This nozzle is exempt from area calculations per UG-36(c)(3)(a)							6,22	6,25

UG-41 Weld Failure Path Analysis Summary
The nozzle is exempt from weld strength calculations per UW-15(b)(2)

UW-16 Weld Sizing Summary			
Weld description	Required weld throat size (mm)	Actual weld throat size (mm)	Status
Nozzle to shell fillet (Leg ₄₁)	2,9	5,6	weld size is adequate

Calculations for internal pressure 45,48 bar @ 175 °C

Parallel Limit of reinforcement per UG-40

$$\begin{aligned}
 L_R &= \max [d, R_n + (t_n - C_n) + (t - C)] \\
 &= \max [39,99, 19,99 + (7,14 - 3) + (7,16 - 3)] \\
 &= 39,99 \text{ mm}
 \end{aligned}$$

Outer Normal Limit of reinforcement per UG-40

$$\begin{aligned}
 L_H &= \min [2,5 \cdot (t - C), 2,5 \cdot (t_n - C_n) + t_e] \\
 &= \min [2,5 \cdot (7,16 - 3), 2,5 \cdot (7,14 - 3) + 0] \\
 &= 10,34 \text{ mm}
 \end{aligned}$$

Nozzle required thickness per UG-27(c)(1)

$$\begin{aligned}
 t_{rn} &= \frac{P \cdot R_n}{S_n \cdot E - 0,6 \cdot P} \\
 &= \frac{45,4848 \cdot 19,99}{1,180 \cdot 1 - 0,6 \cdot 45,4848} \\
 &= 0,79 \text{ mm}
 \end{aligned}$$

Required thickness t_r from UG-37(a)

$$\begin{aligned}
 t_r &= \frac{P \cdot R_o}{S \cdot E + 0,4 \cdot P} \\
 &= \frac{45,4848 \cdot 109,54}{1,180 \cdot 1 + 0,4 \cdot 45,4848} \\
 &= 4,16 \text{ mm}
 \end{aligned}$$

Required thickness t_r per Interpretation VIII-1-07-50

$$\begin{aligned}
t_r &= \frac{P \cdot R_o}{S \cdot E + 0,4 \cdot P} \\
&= \frac{45,4848 \cdot 109,54}{1.180 \cdot 0,85 + 0,4 \cdot 45,4848} \\
&= 4,88 \text{ mm}
\end{aligned}$$

This opening does not require reinforcement per UG-36(c)(3)(a)

UW-16(c) Weld Check

Fillet weld: $t_{\min} = \min [19\text{mm}, t_n, t] = 4,14 \text{ mm}$

$t_{c(\min)} = \min [6 \text{ mm}, 0,7 \cdot t_{\min}] = 2,9 \text{ mm}$

$t_{c(\text{actual})} = 0,7 \cdot \text{Leg} = 0,7 \cdot 8 = 5,6 \text{ mm}$

The fillet weld size is satisfactory.

Weld strength calculations are not required for this detail which conforms to Fig. UW-16.1, sketch (c-e).

UG-45 Nozzle Neck Thickness Check

$$\begin{aligned}
t_{aUG-27} &= \frac{P \cdot R_n}{S_n \cdot E - 0,6 \cdot P} + \text{Corrosion} \\
&= \frac{45,4848 \cdot 19,99}{1.180 \cdot 1 - 0,6 \cdot 45,4848} + 3 \\
&= 3,79 \text{ mm}
\end{aligned}$$

$$\begin{aligned}
t_a &= \max [t_{aUG-27}, t_{aUG-22}] \\
&= \max [3,79, 0] \\
&= 3,79 \text{ mm}
\end{aligned}$$

$$\begin{aligned}
t_{b1} &= \frac{P \cdot R_o}{S \cdot E + 0,4 \cdot P} + \text{Corrosion} \\
&= \frac{45,4848 \cdot 109,54}{1.180 \cdot 1 + 0,4 \cdot 45,4848} + 3 \\
&= 7,16 \text{ mm}
\end{aligned}$$

$$\begin{aligned}
t_{b1} &= \max [t_{b1}, t_{bUG16}] \\
&= \max [7,16, 4,5] \\
&= 7,16 \text{ mm}
\end{aligned}$$

$$\begin{aligned}
t_b &= \min [t_{b3}, t_{b1}] \\
&= \min [6,22, 7,16] \\
&= 6,22 \text{ mm}
\end{aligned}$$

$$\begin{aligned}
t_{UG-45} &= \max [t_a, t_b] \\
&= \max [3,79, 6,22] \\
&= 6,22 \text{ mm}
\end{aligned}$$

Available nozzle wall thickness new, $t_n = 0,875 \cdot 7,14 = 6,25$ mm

The nozzle neck thickness is adequate.

Reinforcement Calculations for MAP

The vessel wall thickness governs the MAP of this nozzle.

UG-37 Area Calculation Summary (cm ²)							UG-45 Summary (mm)	
For P = 79,18 bar @ 21,11 °C							The nozzle passes UG-45	
A required	A available	A ₁	A ₂	A ₃	A ₅	A welds	t _{req}	t _{min}
This nozzle is exempt from area calculations per UG-36(c)(3)(a)							3,22	6,25

UG-41 Weld Failure Path Analysis Summary
The nozzle is exempt from weld strength calculations per UW-15(b)(2)

Calculations for internal pressure 79,18 bar @ 21,11 °C

Parallel Limit of reinforcement per UG-40

$$\begin{aligned}
 L_R &= \max [d, R_n + (t_n - C_n) + (t - C)] \\
 &= \max [33,99, 16,99 + (7,14 - 0) + (7,16 - 0)] \\
 &= 33,99 \text{ mm}
 \end{aligned}$$

Outer Normal Limit of reinforcement per UG-40

$$\begin{aligned}
 L_H &= \min [2,5 \cdot (t - C), 2,5 \cdot (t_n - C_n) + t_e] \\
 &= \min [2,5 \cdot (7,16 - 0), 2,5 \cdot (7,14 - 0) + 0] \\
 &= 17,84 \text{ mm}
 \end{aligned}$$

Nozzle required thickness per UG-27(c)(1)

$$\begin{aligned}
 t_{rn} &= \frac{P \cdot R_n}{S_n \cdot E - 0,6 \cdot P} \\
 &= \frac{79,1796 \cdot 16,99}{1,180 \cdot 1 - 0,6 \cdot 79,1796} \\
 &= 1,19 \text{ mm}
 \end{aligned}$$

Required thickness t_r from UG-37(a)

$$\begin{aligned}
 t_r &= \frac{P \cdot R_o}{S \cdot E + 0,4 \cdot P} \\
 &= \frac{79,1796 \cdot 109,54}{1,180 \cdot 1 + 0,4 \cdot 79,1796} \\
 &= 7,16 \text{ mm}
 \end{aligned}$$

Required thickness t_r per Interpretation VIII-1-07-50

$$\begin{aligned}
 t_r &= \frac{P \cdot R_o}{S \cdot E + 0,4 \cdot P} \\
 &= \frac{79,1796 \cdot 109,54}{1,180 \cdot 0,85 + 0,4 \cdot 79,1796} \\
 &= 8,38 \text{ mm}
 \end{aligned}$$

This opening does not require reinforcement per UG-36(c)(3)(a)

UG-45 Nozzle Neck Thickness Check

$$\begin{aligned}t_{aUG-27} &= \frac{P \cdot R_n}{S_n \cdot E - 0,6 \cdot P} + \text{Corrosion} \\ &= \frac{79,1796 \cdot 16,99}{1.180 \cdot 1 - 0,6 \cdot 79,1796} + 0 \\ &= 1,19 \text{ mm}\end{aligned}$$

$$\begin{aligned}t_a &= \max [t_{aUG-27}, t_{aUG-22}] \\ &= \max [1,19, 0] \\ &= 1,19 \text{ mm}\end{aligned}$$

$$\begin{aligned}t_{b1} &= \frac{P \cdot R_o}{S \cdot E + 0,4 \cdot P} + \text{Corrosion} \\ &= \frac{79,1796 \cdot 109,54}{1.180 \cdot 1 + 0,4 \cdot 79,1796} + 0 \\ &= 7,16 \text{ mm}\end{aligned}$$

$$\begin{aligned}t_{b1} &= \max [t_{b1}, t_{bUG16}] \\ &= \max [7,16, 1,5] \\ &= 7,16 \text{ mm}\end{aligned}$$

$$\begin{aligned}t_b &= \min [t_{b3}, t_{b1}] \\ &= \min [3,22, 7,16] \\ &= 3,22 \text{ mm}\end{aligned}$$

$$\begin{aligned}t_{UG-45} &= \max [t_a, t_b] \\ &= \max [1,19, 3,22] \\ &= \underline{3,22} \text{ mm}\end{aligned}$$

Available nozzle wall thickness new, $t_n = 0,875 \cdot 7,14 = 6,25 \text{ mm}$

The nozzle neck thickness is adequate.

PSV Connection (N5)

ASME Section VIII Division 1, 2021 Edition Metric

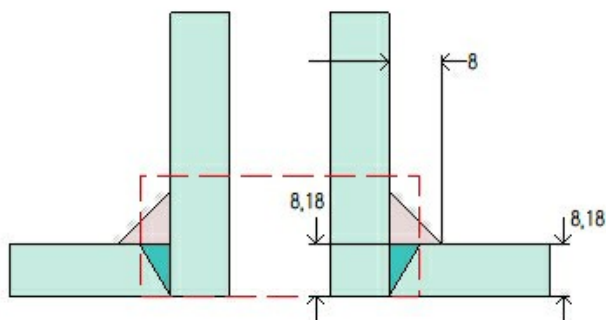

Note: round inside edges per UG-76(c)

Location and Orientation

Located on	Cylinder #1
Orientation	0°
Nozzle center line offset to datum line	725 mm
End of nozzle to shell center	250 mm
Passes through a Category A joint	No

Nozzle

Description	NPS 1 XXS DN 25
Access opening	No
Material specification	SA-106 B Smls Pipe (II-D Metric p. 16, In. 16)
Inside diameter, new	15,21 mm
Pipe nominal wall thickness	9,09 mm
Pipe minimum wall thickness ¹	7,96 mm
Corrosion allowance	3 mm
Projection available outside vessel, L _{pr}	72,14 mm
Projection available outside vessel to flange face, L _f	140,47 mm
Local vessel minimum thickness	7,16 mm
Liquid static head included	0 bar

Welds

Inner fillet, Leg ₄₁	8 mm
Nozzle to vessel groove weld	8,18 mm

Radiography

Longitudinal seam	Seamless No RT
Circumferential seam	Full UW-11(a) Type 1

¹Pipe minimum thickness = nominal thickness times pipe tolerance factor of 0,875.

ASME B16.5-2017 Flange	
Description	NPS 1 Class 600 WN A105
Bolt Material	SA-193 B7 Bolt <= 64 (II-D Metric p. 410, ln. 32)
Blind included	No
Rated MDMT	-48°C
Liquid static head	0 bar
MAWP rating	88,9 bar @ 175°C
MAP rating	102,1 bar @ 21,11°C
Hydrotest rating	154 bar @ 21,11°C
PWHT performed	No
Produced to Fine Grain Practice and Supplied in Heat Treated Condition	No
Impact Tested	No
Circumferential joint radiography	Full UW-11(a) Type 1
Bore diameter, B (specified by purchaser)	26,67 mm
Gasket	
Type	ASME B16.20 Spiral-Wound
Description	Garlock FLEXSEAL RW 316L SS / Flexible Graphite
Factor, m	3
Seating Stress, y	703,07 kgf/cm ²
Thickness, T	3 mm
Inner Diameter	31,8 mm
Outer Diameter	47,8 mm
Notes	
Flange rated MDMT per UCS-66(b)(1)(b) = -48°C (Coincident ratio = 0,3786) Bolts rated MDMT per Fig UCS-66 note (c) = -48°C	

UCS-66 Material Toughness Requirements Nozzle At Intersection	
Governing thickness, $t_g =$	7,16 mm
Exemption temperature from Fig UCS-66M Curve B =	-29°C
$t_r = \frac{38,66 \cdot 109,54}{1.180 \cdot 1 + 0,4 \cdot 38,66} =$	3,54 mm
Stress ratio = $\frac{t_r \cdot E^*}{t_n - c} = \frac{3,54 \cdot 1}{7,16 - 3} =$	0,8519
Reduction in MDMT, T_R from Fig UCS-66.1M =	8,3°C
$MDMT = \max [MDMT - T_R, -48] = \max [-29 - 8,3, -48] =$	-37,3°C
Material is exempt from impact testing at the Design MDMT of 0°C.	

UCS-66 Material Toughness Requirements Nozzle	
Impact test exempt per UCS-66(d) (NPS 4 or smaller pipe) =	-105°C
Material is exempt from impact testing at the Design MDMT of 0°C.	

Reinforcement Calculations for Internal Pressure

UG-37 Area Calculation Summary (cm ²)							UG-45 Summary (mm)	
For P = 30,5 bar @ 175 °C							The nozzle passes UG-45	
A required	A available	A ₁	A ₂	A ₃	A ₅	A welds	t _{req}	t _{min}
This nozzle is exempt from area calculations per UG-36(c)(3)(a)							5,8	7,96

UG-41 Weld Failure Path Analysis Summary
The nozzle is exempt from weld strength calculations per UW-15(b)(2)

UW-16 Weld Sizing Summary			
Weld description	Required weld throat size (mm)	Actual weld throat size (mm)	Status
Nozzle to shell fillet (Leg ₄₁)	2,91	5,6	weld size is adequate

Calculations for internal pressure 30,5 bar @ 175 °C

Parallel Limit of reinforcement per UG-40

$$\begin{aligned}
 L_R &= \max [d, R_n + (t_n - C_n) + (t - C)] \\
 &= \max [21,21, 10,61 + (9,09 - 3) + (7,16 - 3)] \\
 &= 21,21 \text{ mm}
 \end{aligned}$$

Outer Normal Limit of reinforcement per UG-40

$$\begin{aligned}
 L_H &= \min [2,5 \cdot (t - C), 2,5 \cdot (t_n - C_n) + t_e] \\
 &= \min [2,5 \cdot (7,16 - 3), 2,5 \cdot (9,09 - 3) + 0] \\
 &= 10,4 \text{ mm}
 \end{aligned}$$

Nozzle required thickness per UG-27(c)(1)

$$\begin{aligned}
 t_{rn} &= \frac{P \cdot R_n}{S_n \cdot E - 0,6 \cdot P} \\
 &= \frac{30,5001 \cdot 10,61}{1,180 \cdot 1 - 0,6 \cdot 30,5001} \\
 &= 0,28 \text{ mm}
 \end{aligned}$$

Required thickness t_r from UG-37(a)

$$\begin{aligned}
 t_r &= \frac{P \cdot R_o}{S \cdot E + 0,4 \cdot P} \\
 &= \frac{30,5001 \cdot 109,54}{1,180 \cdot 1 + 0,4 \cdot 30,5001} \\
 &= 2,8 \text{ mm}
 \end{aligned}$$

Required thickness t_r per Interpretation VIII-1-07-50

$$\begin{aligned}
t_r &= \frac{P \cdot R_o}{S \cdot E + 0,4 \cdot P} \\
&= \frac{30,5001 \cdot 109,54}{1,180 \cdot 0,85 + 0,4 \cdot 30,5001} \\
&= 3,29 \text{ mm}
\end{aligned}$$

This opening does not require reinforcement per UG-36(c)(3)(a)

UW-16(c) Weld Check

Fillet weld: $t_{\min} = \min [19mm, t_n, t] = 4,16 \text{ mm}$

$t_{c(\min)} = \min [6 \text{ mm}, 0,7 \cdot t_{\min}] = 2,91 \text{ mm}$

$t_{c(\text{actual})} = 0,7 \cdot \text{Leg} = 0,7 \cdot 8 = 5,6 \text{ mm}$

The fillet weld size is satisfactory.

Weld strength calculations are not required for this detail which conforms to Fig. UW-16.1, sketch (c-e).

UG-45 Nozzle Neck Thickness Check

$$\begin{aligned}
t_{aUG-27} &= \frac{P \cdot R_n}{S_n \cdot E - 0,6 \cdot P} + \text{Corrosion} \\
&= \frac{30,5001 \cdot 10,61}{1,180 \cdot 1 - 0,6 \cdot 30,5001} + 3 \\
&= 3,28 \text{ mm}
\end{aligned}$$

$$\begin{aligned}
t_a &= \max [t_{aUG-27}, t_{aUG-22}] \\
&= \max [3,28, 0] \\
&= 3,28 \text{ mm}
\end{aligned}$$

$$\begin{aligned}
t_{b1} &= \frac{P \cdot R_o}{S \cdot E + 0,4 \cdot P} + \text{Corrosion} \\
&= \frac{30,5001 \cdot 109,54}{1,180 \cdot 1 + 0,4 \cdot 30,5001} + 3 \\
&= 5,8 \text{ mm}
\end{aligned}$$

$$\begin{aligned}
t_{b1} &= \max [t_{b1}, t_{bUG16}] \\
&= \max [5,8, 4,5] \\
&= 5,8 \text{ mm}
\end{aligned}$$

$$\begin{aligned}
t_b &= \min [t_{b3}, t_{b1}] \\
&= \min [5,96, 5,8] \\
&= 5,8 \text{ mm}
\end{aligned}$$

$$\begin{aligned}
t_{UG-45} &= \max [t_a, t_b] \\
&= \max [3,28, 5,8] \\
&= 5,8 \text{ mm}
\end{aligned}$$

Available nozzle wall thickness new, $t_n = 0,875 \cdot 9,09 = 7,96$ mm

The nozzle neck thickness is adequate.

Reinforcement Calculations for MAWP

The vessel wall thickness governs the MAWP of this nozzle.

UG-37 Area Calculation Summary (cm ²)							UG-45 Summary (mm)	
For P = 45,48 bar @ 175 °C							The nozzle passes UG-45	
A required	A available	A ₁	A ₂	A ₃	A ₅	A welds	t _{req}	t _{min}
This nozzle is exempt from area calculations per UG-36(c)(3)(a)							5,96	7,96

UG-41 Weld Failure Path Analysis Summary
The nozzle is exempt from weld strength calculations per UW-15(b)(2)

UW-16 Weld Sizing Summary			
Weld description	Required weld throat size (mm)	Actual weld throat size (mm)	Status
Nozzle to shell fillet (Leg ₄₁)	2,91	5,6	weld size is adequate

Calculations for internal pressure 45,48 bar @ 175 °C

Parallel Limit of reinforcement per UG-40

$$\begin{aligned}
 L_R &= \max [d, R_n + (t_n - C_n) + (t - C)] \\
 &= \max [21,21, 10,61 + (9,09 - 3) + (7,16 - 3)] \\
 &= 21,21 \text{ mm}
 \end{aligned}$$

Outer Normal Limit of reinforcement per UG-40

$$\begin{aligned}
 L_H &= \min [2,5 \cdot (t - C), 2,5 \cdot (t_n - C_n) + t_e] \\
 &= \min [2,5 \cdot (7,16 - 3), 2,5 \cdot (9,09 - 3) + 0] \\
 &= 10,4 \text{ mm}
 \end{aligned}$$

Nozzle required thickness per UG-27(c)(1)

$$\begin{aligned}
 t_{rn} &= \frac{P \cdot R_n}{S_n \cdot E - 0,6 \cdot P} \\
 &= \frac{45,4848 \cdot 10,61}{1,180 \cdot 1 - 0,6 \cdot 45,4848} \\
 &= 0,42 \text{ mm}
 \end{aligned}$$

Required thickness t_r from UG-37(a)

$$\begin{aligned}
 t_r &= \frac{P \cdot R_o}{S \cdot E + 0,4 \cdot P} \\
 &= \frac{45,4848 \cdot 109,54}{1,180 \cdot 1 + 0,4 \cdot 45,4848} \\
 &= 4,16 \text{ mm}
 \end{aligned}$$

Required thickness t_r per Interpretation VIII-1-07-50

$$\begin{aligned}
t_r &= \frac{P \cdot R_o}{S \cdot E + 0,4 \cdot P} \\
&= \frac{45,4848 \cdot 109,54}{1.180 \cdot 0,85 + 0,4 \cdot 45,4848} \\
&= 4,88 \text{ mm}
\end{aligned}$$

This opening does not require reinforcement per UG-36(c)(3)(a)

UW-16(c) Weld Check

Fillet weld: $t_{\min} = \min [19\text{mm}, t_n, t] = 4,16 \text{ mm}$

$$t_{c(\min)} = \min [6 \text{ mm}, 0,7 \cdot t_{\min}] = \underline{2,91} \text{ mm}$$

$$t_{c(\text{actual})} = 0,7 \cdot \text{Leg} = 0,7 \cdot 8 = 5,6 \text{ mm}$$

The fillet weld size is satisfactory.

Weld strength calculations are not required for this detail which conforms to Fig. UW-16.1, sketch (c-e).

UG-45 Nozzle Neck Thickness Check

$$\begin{aligned}
t_{aUG-27} &= \frac{P \cdot R_n}{S_n \cdot E - 0,6 \cdot P} + \text{Corrosion} \\
&= \frac{45,4848 \cdot 10,61}{1.180 \cdot 1 - 0,6 \cdot 45,4848} + 3 \\
&= 3,42 \text{ mm}
\end{aligned}$$

$$\begin{aligned}
t_a &= \max [t_{aUG-27}, t_{aUG-22}] \\
&= \max [3,42, 0] \\
&= 3,42 \text{ mm}
\end{aligned}$$

$$\begin{aligned}
t_{b1} &= \frac{P \cdot R_o}{S \cdot E + 0,4 \cdot P} + \text{Corrosion} \\
&= \frac{45,4848 \cdot 109,54}{1.180 \cdot 1 + 0,4 \cdot 45,4848} + 3 \\
&= 7,16 \text{ mm}
\end{aligned}$$

$$\begin{aligned}
t_{b1} &= \max [t_{b1}, t_{bUG16}] \\
&= \max [7,16, 4,5] \\
&= 7,16 \text{ mm}
\end{aligned}$$

$$\begin{aligned}
t_b &= \min [t_{b3}, t_{b1}] \\
&= \min [5,96, 7,16] \\
&= 5,96 \text{ mm}
\end{aligned}$$

$$\begin{aligned}
t_{UG-45} &= \max [t_a, t_b] \\
&= \max [3,42, 5,96] \\
&= \underline{5,96} \text{ mm}
\end{aligned}$$

Available nozzle wall thickness new, $t_n = 0,875 \cdot 9,09 = 7,96$ mm

The nozzle neck thickness is adequate.

Reinforcement Calculations for MAP

The vessel wall thickness governs the MAP of this nozzle.

UG-37 Area Calculation Summary (cm ²)							UG-45 Summary (mm)	
For P = 79,18 bar @ 21,11 °C							The nozzle passes UG-45	
A required	A available	A ₁	A ₂	A ₃	A ₅	A welds	t _{req}	t _{min}
This nozzle is exempt from area calculations per UG-36(c)(3)(a)							2,96	7,96

UG-41 Weld Failure Path Analysis Summary
The nozzle is exempt from weld strength calculations per UW-15(b)(2)

Calculations for internal pressure 79,18 bar @ 21,11 °C

Parallel Limit of reinforcement per UG-40

$$\begin{aligned}
 L_R &= \max [d, R_n + (t_n - C_n) + (t - C)] \\
 &= \max [15,21, 7,61 + (9,09 - 0) + (7,16 - 0)] \\
 &= 23,86 \text{ mm}
 \end{aligned}$$

Outer Normal Limit of reinforcement per UG-40

$$\begin{aligned}
 L_H &= \min [2,5 \cdot (t - C), 2,5 \cdot (t_n - C_n) + t_e] \\
 &= \min [2,5 \cdot (7,16 - 0), 2,5 \cdot (9,09 - 0) + 0] \\
 &= 17,89 \text{ mm}
 \end{aligned}$$

Nozzle required thickness per UG-27(c)(1)

$$\begin{aligned}
 t_{rn} &= \frac{P \cdot R_n}{S_n \cdot E - 0,6 \cdot P} \\
 &= \frac{79,1796 \cdot 7,61}{1,180 \cdot 1 - 0,6 \cdot 79,1796} \\
 &= 0,53 \text{ mm}
 \end{aligned}$$

Required thickness t_r from UG-37(a)

$$\begin{aligned}
 t_r &= \frac{P \cdot R_o}{S \cdot E + 0,4 \cdot P} \\
 &= \frac{79,1796 \cdot 109,54}{1,180 \cdot 1 + 0,4 \cdot 79,1796} \\
 &= 7,16 \text{ mm}
 \end{aligned}$$

Required thickness t_r per Interpretation VIII-1-07-50

$$\begin{aligned}
 t_r &= \frac{P \cdot R_o}{S \cdot E + 0,4 \cdot P} \\
 &= \frac{79,1796 \cdot 109,54}{1,180 \cdot 0,85 + 0,4 \cdot 79,1796} \\
 &= 8,38 \text{ mm}
 \end{aligned}$$

This opening does not require reinforcement per UG-36(c)(3)(a)

UG-45 Nozzle Neck Thickness Check

$$\begin{aligned}t_{aUG-27} &= \frac{P \cdot R_n}{S_n \cdot E - 0,6 \cdot P} + \text{Corrosion} \\ &= \frac{79,1796 \cdot 7,61}{1.180 \cdot 1 - 0,6 \cdot 79,1796} + 0 \\ &= 0,53 \text{ mm}\end{aligned}$$

$$\begin{aligned}t_a &= \max [t_{aUG-27}, t_{aUG-22}] \\ &= \max [0,53, 0] \\ &= 0,53 \text{ mm}\end{aligned}$$

$$\begin{aligned}t_{b1} &= \frac{P \cdot R_o}{S \cdot E + 0,4 \cdot P} + \text{Corrosion} \\ &= \frac{79,1796 \cdot 109,54}{1.180 \cdot 1 + 0,4 \cdot 79,1796} + 0 \\ &= 7,16 \text{ mm}\end{aligned}$$

$$\begin{aligned}t_{b1} &= \max [t_{b1}, t_{bUG16}] \\ &= \max [7,16, 1,5] \\ &= 7,16 \text{ mm}\end{aligned}$$

$$\begin{aligned}t_b &= \min [t_{b3}, t_{b1}] \\ &= \min [2,96, 7,16] \\ &= 2,96 \text{ mm}\end{aligned}$$

$$\begin{aligned}t_{UG-45} &= \max [t_a, t_b] \\ &= \max [0,53, 2,96] \\ &= \underline{2,96} \text{ mm}\end{aligned}$$

Available nozzle wall thickness new, $t_n = 0,875 \cdot 9,09 = 7,96 \text{ mm}$

The nozzle neck thickness is adequate.

Drain (N6)

ASME Section VIII Division 1, 2021 Edition Metric

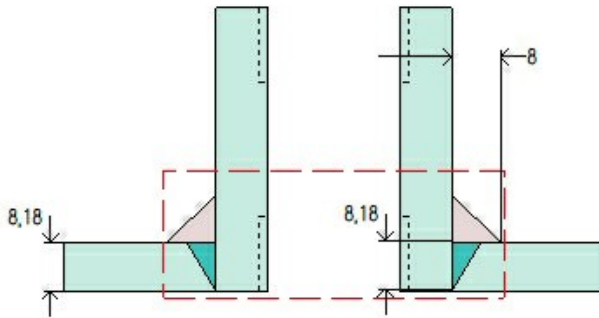

Note: round inside edges per UG-76(c)

Location and Orientation	
Located on	Cylinder #1
Orientation	180°
Nozzle center line offset to datum line	420 mm
End of nozzle to shell center	147,3 mm
Passes through a Category A joint	No
Nozzle	
Description	NPS 0,5 Class 6000 DN 15 - Threaded Full Coupling
Access opening	No
Material specification	SA-105 (II-D Metric p. 20, ln. 31)
Inside diameter, new	21,34 mm
Nominal wall thickness	8,38 mm
Corrosion allowance	3 mm
Projection available outside vessel, L _{pr}	37,77 mm
Local vessel minimum thickness	7,16 mm
Liquid static head included	0 bar
Welds	
Inner fillet, Leg ₄₁	8 mm
Nozzle to vessel groove weld	8,18 mm
Radiography	
Longitudinal seam	Seamless No RT

UCS-66 Material Toughness Requirements Nozzle At Intersection	
Governing thickness, $t_g =$	7,16 mm
Exemption temperature from Fig UCS-66M Curve B =	-29°C
$t_r = \frac{38,66 \cdot 109,54}{1.180 \cdot 1 + 0,4 \cdot 38,66} =$	3,54 mm
$\text{Stress ratio} = \frac{t_r \cdot E^*}{t_n - c} = \frac{3,54 \cdot 1}{7,16 - 3} =$	0,8519
Reduction in MDMT, T_R from Fig UCS-66.1M =	8,3°C
$MDMT = \max [MDMT - T_R, -48] = \max [-29 - 8,3, -48] =$	-37,3°C
Material is exempt from impact testing at the Design MDMT of 0°C.	

UCS-66 Material Toughness Requirements Nozzle	
$t_r = \frac{38,66 \cdot 13,67}{1.380 \cdot 1 - 0,6 \cdot 38,66} =$	0,39 mm
Stress ratio = $\frac{t_r \cdot E^*}{t_n - c} = \frac{0,39 \cdot 1}{8,38 - 3} =$	0,0724
Stress ratio $\leq 0,35$, MDMT per UCS-66(b)(3) =	-105°C
Material is exempt from impact testing at the Design MDMT of 0°C.	

Reinforcement Calculations for Internal Pressure

UG-37 Area Calculation Summary (cm ²)							UG-44 Summary (mm)	
For P = 30,5 bar @ 175 °C							The nozzle passes UG-44	
A required	A available	A ₁	A ₂	A ₃	A ₅	A welds	t _{req}	t _{min}
This nozzle is exempt from area calculations per UG-36(c)(3)(a)							4,5	8,38

UG-41 Weld Failure Path Analysis Summary
The nozzle is exempt from weld strength calculations per UW-15(b)(2)

UW-16 Weld Sizing Summary			
Weld description	Required weld throat size (mm)	Actual weld throat size (mm)	Status
Nozzle to shell fillet (Leg ₄₁)	2,5	5,6	weld size is adequate

Calculations for internal pressure 30,5 bar @ 175 °C

Parallel Limit of reinforcement per UG-40

$$\begin{aligned}
 L_R &= \max [d, R_n + (t_n - C_n) + (t - C)] \\
 &= \max [27,34, 13,67 + (8,38 - 3) + (7,16 - 3)] \\
 &= 27,34 \text{ mm}
 \end{aligned}$$

Outer Normal Limit of reinforcement per UG-40

$$\begin{aligned}
 L_H &= \min [2,5 \cdot (t - C), 2,5 \cdot (t_n - C_n) + t_e] \\
 &= \min [2,5 \cdot (7,16 - 3), 2,5 \cdot (8,38 - 3) + 0] \\
 &= 10,4 \text{ mm}
 \end{aligned}$$

Nozzle required thickness per UG-27(c)(1)

$$\begin{aligned}
 t_{rn} &= \frac{P \cdot R_n}{S_n \cdot E - 0,6 \cdot P} \\
 &= \frac{30,5001 \cdot 13,67}{1,380 \cdot 1 - 0,6 \cdot 30,5001} \\
 &= 0,31 \text{ mm}
 \end{aligned}$$

Required thickness t_r from UG-37(a)

$$\begin{aligned}
 t_r &= \frac{P \cdot R_o}{S \cdot E + 0,4 \cdot P} \\
 &= \frac{30,5001 \cdot 109,54}{1,180 \cdot 1 + 0,4 \cdot 30,5001} \\
 &= 2,8 \text{ mm}
 \end{aligned}$$

Required thickness t_r per Interpretation VIII-1-07-50

$$\begin{aligned}
 t_r &= \frac{P \cdot R_o}{S \cdot E + 0,4 \cdot P} \\
 &= \frac{30,5001 \cdot 109,54}{1,180 \cdot 0,85 + 0,4 \cdot 30,5001} \\
 &= 3,29 \text{ mm}
 \end{aligned}$$

This opening does not require reinforcement per UG-36(c)(3)(a)

UW-16(f)(2)(b) Weld Check

Fillet weld: $t_{\min} = \min [19\text{mm}, t_n, t] = 4,16 \text{ mm}$

$t_{c(\min)} = \min [2,5 \text{ mm}, 0,7 \cdot t_{\min}] = 2,5 \text{ mm}$

$t_{c(\text{actual})} = 0,7 \cdot \text{Leg} = 0,7 \cdot 8 = 5,6 \text{ mm}$

The fillet weld size is satisfactory.

Weld strength calculations are not required for this detail which conforms to Fig. UW-16.1, sketch (c-e).

UG-44 Thickness Check - ASME B16.11 Coupling

$$\begin{aligned}
 t_{a\text{App } 1-1} &= \frac{P \cdot R_o}{S_n \cdot E + 0,4 \cdot P} + \text{Corrosion} \\
 &= \frac{30,5001 \cdot 19,05}{1,380 \cdot 1 + 0,4 \cdot 30,5001} + 3 \\
 &= 3,42 \text{ mm}
 \end{aligned}$$

$$\begin{aligned}
 t_{a\text{UG-44}} &= \max [t_{a\text{App } 1-1}, t_{b\text{UG16}}] \\
 &= \max [3,42, 4,5] \\
 &= 4,5 \text{ mm}
 \end{aligned}$$

Available nozzle wall thickness new, $t_n = 8,38 \text{ mm}$

The nozzle neck thickness is adequate.

Reinforcement Calculations for MAWP

The vessel wall thickness governs the MAWP of this nozzle.

UG-37 Area Calculation Summary (cm ²)							UG-44 Summary (mm)	
For P = 45,48 bar @ 175 °C							The nozzle passes UG-44	
A required	A available	A ₁	A ₂	A ₃	A ₅	A welds	t _{req}	t _{min}
This nozzle is exempt from area calculations per UG-36(c)(3)(a)							4,5	8,38

UG-41 Weld Failure Path Analysis Summary
The nozzle is exempt from weld strength calculations per UW-15(b)(2)

UW-16 Weld Sizing Summary			
Weld description	Required weld throat size (mm)	Actual weld throat size (mm)	Status
Nozzle to shell fillet (Leg ₄₁)	2,5	5,6	weld size is adequate

Calculations for internal pressure 45,48 bar @ 175 °C

Parallel Limit of reinforcement per UG-40

$$\begin{aligned}
 L_R &= \max [d, R_n + (t_n - C_n) + (t - C)] \\
 &= \max [27,34, 13,67 + (8,38 - 3) + (7,16 - 3)] \\
 &= 27,34 \text{ mm}
 \end{aligned}$$

Outer Normal Limit of reinforcement per UG-40

$$\begin{aligned}
 L_H &= \min [2,5 \cdot (t - C), 2,5 \cdot (t_n - C_n) + t_e] \\
 &= \min [2,5 \cdot (7,16 - 3), 2,5 \cdot (8,38 - 3) + 0] \\
 &= 10,4 \text{ mm}
 \end{aligned}$$

Nozzle required thickness per UG-27(c)(1)

$$\begin{aligned}
 t_{rn} &= \frac{P \cdot R_n}{S_n \cdot E - 0,6 \cdot P} \\
 &= \frac{45,4848 \cdot 13,67}{1,380 \cdot 1 - 0,6 \cdot 45,4848} \\
 &= 0,46 \text{ mm}
 \end{aligned}$$

Required thickness t_r from UG-37(a)

$$\begin{aligned}
 t_r &= \frac{P \cdot R_o}{S \cdot E + 0,4 \cdot P} \\
 &= \frac{45,4848 \cdot 109,54}{1,180 \cdot 1 + 0,4 \cdot 45,4848} \\
 &= 4,16 \text{ mm}
 \end{aligned}$$

Required thickness t_r per Interpretation VIII-1-07-50

$$\begin{aligned}
 t_r &= \frac{P \cdot R_o}{S \cdot E + 0,4 \cdot P} \\
 &= \frac{45,4848 \cdot 109,54}{1.180 \cdot 0,85 + 0,4 \cdot 45,4848} \\
 &= 4,88 \text{ mm}
 \end{aligned}$$

This opening does not require reinforcement per UG-36(c)(3)(a)

UW-16(f)(2)(b) Weld Check

Fillet weld: $t_{\min} = \min [19\text{mm}, t_n, t] = 4,16 \text{ mm}$

$$t_{c(\min)} = \min [2,5 \text{ mm}, 0,7 \cdot t_{\min}] = 2,5 \text{ mm}$$

$$t_{c(\text{actual})} = 0,7 \cdot \text{Leg} = 0,7 \cdot 8 = 5,6 \text{ mm}$$

The fillet weld size is satisfactory.

Weld strength calculations are not required for this detail which conforms to Fig. UW-16.1, sketch (c-e).

UG-44 Thickness Check - ASME B16.11 Coupling

$$\begin{aligned}
 t_{a\text{App } 1-1} &= \frac{P \cdot R_o}{S_n \cdot E + 0,4 \cdot P} + \text{Corrosion} \\
 &= \frac{45,4848 \cdot 19,05}{1.380 \cdot 1 + 0,4 \cdot 45,4848} + 3 \\
 &= 3,62 \text{ mm}
 \end{aligned}$$

$$\begin{aligned}
 t_{a\text{UG-44}} &= \max [t_{a\text{App } 1-1}, t_{b\text{UG16}}] \\
 &= \max [3,62, 4,5] \\
 &= 4,5 \text{ mm}
 \end{aligned}$$

Available nozzle wall thickness new, $t_n = 8,38 \text{ mm}$

The nozzle neck thickness is adequate.

Reinforcement Calculations for MAP

The vessel wall thickness governs the MAP of this nozzle.

UG-37 Area Calculation Summary (cm ²)							UG-44 Summary (mm)	
For P = 79,18 bar @ 21,11 °C							The nozzle passes UG-44	
A required	A available	A ₁	A ₂	A ₃	A ₅	A welds	t _{req}	t _{min}
This nozzle is exempt from area calculations per UG-36(c)(3)(a)							1,5	8,38

UG-41 Weld Failure Path Analysis Summary
The nozzle is exempt from weld strength calculations per UW-15(b)(2)

Calculations for internal pressure 79,18 bar @ 21,11 °C

Parallel Limit of reinforcement per UG-40

$$\begin{aligned}
 L_R &= \max [d, R_n + (t_n - C_n) + (t - C)] \\
 &= \max [21,34, 10,67 + (8,38 - 0) + (7,16 - 0)] \\
 &= 26,21 \text{ mm}
 \end{aligned}$$

Outer Normal Limit of reinforcement per UG-40

$$\begin{aligned}
 L_H &= \min [2,5 \cdot (t - C), 2,5 \cdot (t_n - C_n) + t_e] \\
 &= \min [2,5 \cdot (7,16 - 0), 2,5 \cdot (8,38 - 0) + 0] \\
 &= 17,89 \text{ mm}
 \end{aligned}$$

Nozzle required thickness per UG-27(c)(1)

$$\begin{aligned}
 t_{rn} &= \frac{P \cdot R_n}{S_n \cdot E - 0,6 \cdot P} \\
 &= \frac{79,1796 \cdot 10,67}{1,380 \cdot 1 - 0,6 \cdot 79,1796} \\
 &= 0,64 \text{ mm}
 \end{aligned}$$

Required thickness t_r from UG-37(a)

$$\begin{aligned}
 t_r &= \frac{P \cdot R_o}{S \cdot E + 0,4 \cdot P} \\
 &= \frac{79,1796 \cdot 109,54}{1,180 \cdot 1 + 0,4 \cdot 79,1796} \\
 &= 7,16 \text{ mm}
 \end{aligned}$$

Required thickness t_r per Interpretation VIII-1-07-50

$$\begin{aligned}
 t_r &= \frac{P \cdot R_o}{S \cdot E + 0,4 \cdot P} \\
 &= \frac{79,1796 \cdot 109,54}{1,180 \cdot 0,85 + 0,4 \cdot 79,1796} \\
 &= 8,38 \text{ mm}
 \end{aligned}$$

This opening does not require reinforcement per UG-36(c)(3)(a)

UG-44 Thickness Check - ASME B16.11 Coupling

$$\begin{aligned}t_{aApp\ 1-1} &= \frac{P \cdot R_o}{S_n \cdot E + 0,4 \cdot P} + \text{Corrosion} \\ &= \frac{79,1796 \cdot 19,05}{1.380 \cdot 1 + 0,4 \cdot 79,1796} + 0 \\ &= 1,07 \text{ mm}\end{aligned}$$

$$\begin{aligned}t_{aUG-44} &= \max [t_{aApp\ 1-1}, t_{UG16}] \\ &= \max [1,07, 1,5] \\ &= 1,5 \text{ mm}\end{aligned}$$

Available nozzle wall thickness new, $t_n = 8,38 \text{ mm}$

The nozzle neck thickness is adequate.

Straight Flange on B16.9 Pipe Cap - Right Side

ASME Section VIII Division 1, 2021 Edition Metric				
Component		Cylinder		
Material		SA-234 WPB (II-D Metric p. 16, ln. 18)		
Impact Tested	Normalized	Fine Grain Practice	PWHT	Maximize MDMT/ No MAWP
No	No	No	No	No
		Design Pressure (bar)	Design Temperature (°C)	Design MDMT (°C)
Internal		30,5	175	0
Static Liquid Head				
Condition		P_s (bar)	H_s (mm)	SG
Test horizontal		0,03	351,36	1
Dimensions				
Outer Diameter		219,07 mm		
Length		44,17 mm		
Nominal Thickness		8,18 mm		
Corrosion	Inner	3 mm		
	Outer	0 mm		
Weight and Capacity				
		Weight (kg)	Capacity (liters)	
New		1,87	1,43	
Corroded		1,2	1,51	
Radiography				
Longitudinal seam		Seamless No RT		
Left Circumferential seam		Spot UW-11(b) Type 1		

Results Summary	
Governing condition	Internal pressure
Minimum thickness per UG-16	1,5 mm + 3 mm = 4,5 mm
Design thickness due to internal pressure (t)	6,29 mm
Maximum allowable working pressure (MAWP)	48,35 bar
Maximum allowable pressure (MAP)	77,21 bar
Rated MDMT	-46,8 °C

UCS-66 Material Toughness Requirements	
Governing thickness, t _g =	7,16 mm
Exemption temperature from Fig UCS-66M Curve B =	-29°C
$t_r = \frac{38,66 \cdot 109,54}{1,180 \cdot 0,85 + 0,4 \cdot 38,66} =$	4,16 mm
$\text{Stress ratio} = \frac{t_r \cdot E^*}{t_n - c} = \frac{4,16 \cdot 0,85}{8,18 - 3} =$	0,6822
Reduction in MDMT, T _R from Fig UCS-66.1M =	17,8°C
$MDMT = \max [MDMT - T_R, -48] = \max [-29 - 17,8, -48] =$	-46,8°C
Material is exempt from impact testing at the Design MDMT of 0°C.	

Design thickness, (at 175 °C) Appendix 1-1

$$t = \frac{P \cdot R_o}{S \cdot E + 0,40 \cdot P} + \text{Corrosion} = \frac{30,5 \cdot 109,54}{1.180 \cdot 0,85 + 0,40 \cdot 30,5} + 3 = 6,29 \text{ mm}$$

Maximum allowable working pressure, (at 175 °C) Appendix 1-1

$$P = \frac{S \cdot E \cdot t}{R_o - 0,40 \cdot t} - P_s = \frac{1.180 \cdot 0,85 \cdot 5,18}{109,54 - 0,40 \cdot 5,18} - 0 = 48,35 \text{ bar}$$

Maximum allowable pressure, (at 21,11 °C) Appendix 1-1

$$P = \frac{S \cdot E \cdot t}{R_o - 0,40 \cdot t} = \frac{1.180 \cdot 0,85 \cdot 8,18}{109,54 - 0,40 \cdot 8,18} = 77,21 \text{ bar}$$

ASME Section VIII Division 1 UG-80(a) Out-of-Roundness
$(D_{\max} - D_{\min})$ shall not exceed 1% of D
When the cross section passes through an opening or within 1 I.D. of the opening, $(D_{\max} - D_{\min})$ shall not exceed 1% of $D + 2\%$ of the inside diameter of the opening

B16.9 Pipe Cap - Right Side

ASME Section VIII Division 1, 2021 Edition Metric				
Component		ASME B16.9 Pipe Cap (modified)		
Material		SA-234 WPB (II-D Metric p. 16, In. 18)		
Attached To		Cylinder #1		
Impact Tested	Normalized	Fine Grain Practice	PWHT	Maximize MDMT/ No MAWP
No	No	No	No	No
		Design Pressure (bar)	Design Temperature (°C)	Design MDMT (°C)
Internal		30,5	175	0
Static Liquid Head				
Condition		P_s (bar)	H_s (mm)	SG
Test horizontal		0,03	351,36	1
Dimensions				
NPS and Schedule		NPS 8 Sch 40 (Std) DN 200		
Outer Diameter		219,07 mm		
Overall Length E		102 mm		
Nominal Thickness		8,18 mm		
Minimum Thickness¹		7,16 mm		
Corrosion	Inner	3 mm		
	Outer	0 mm		
Length L_{sf}		44,17 mm		
Nominal Thickness t_{sf}		8,18 mm		
Weight and Capacity				
		Weight (kg)²		Capacity (liters)²
New		5,19		2,52
Corroded		3,38		2,74
Radiography				
Category A joints		Seamless No RT		
Head to shell seam		Spot UW-11(b) Type 1		

¹ minimum thickness = nominal thickness times pipe tolerance factor of 0,875.

² includes straight flange

Results Summary	
Governing condition	internal pressure
Minimum thickness per UG-16	1,5 mm + 3 mm = 4,5 mm
Design thickness due to internal pressure (t)	6.13 mm
Governing straight flange design thickness	6,29 mm
Maximum allowable working pressure (MAWP)	40.92 bar
Maximum allowable pressure (MAP)	69.64 bar
Straight Flange governs MDMT	-46,8°C

Factor K		
	$K = \left(\frac{1}{6}\right) \cdot \left[2 + \left(\frac{D}{2 \cdot h}\right)^2\right]$	
Corroded	$K = \left(\frac{1}{6}\right) \cdot \left[2 + \left(\frac{208,71}{2 \cdot 53,68}\right)^2\right]$	0,9633
New	$K = \left(\frac{1}{6}\right) \cdot \left[2 + \left(\frac{202,71}{2 \cdot 50,68}\right)^2\right]$	1

Design thickness for internal pressure, (Corroded at 175 °C) Appendix 1-4(c)

$$t = \frac{P \cdot D_o \cdot K}{2 \cdot S \cdot E + 2 \cdot P \cdot (K - 0,1)} + \text{Corrosion} = \frac{30,5 \cdot 219,07 \cdot 0,963264}{2 \cdot 1.180 \cdot 0,85 + 2 \cdot 30,5 \cdot (0,963264 - 0,1)} + 3 = 6.13 \text{ mm}$$

Maximum allowable working pressure, (Corroded at 175 °C) Appendix 1-4(c)

$$P = \frac{2 \cdot S \cdot E \cdot t}{K \cdot D_o - 2 \cdot t \cdot (K - 0,1)} - P_s = \frac{2 \cdot 1.180 \cdot 0,85 \cdot (0,875 \cdot 8,18 - 3)}{0,963264 \cdot 219,07 - 2 \cdot (0,875 \cdot 8,18 - 3) \cdot (0,963264 - 0,1)} - 0 = 40.92 \text{ bar}$$

Maximum allowable pressure, (New at 21,11 °C) Appendix 1-4(c)

$$P = \frac{2 \cdot S \cdot E \cdot t}{K \cdot D_o - 2 \cdot t \cdot (K - 0,1)} - P_s = \frac{2 \cdot 1.180 \cdot 0,85 \cdot 0,875 \cdot 8,18}{1 \cdot 219,07 - 2 \cdot 0,875 \cdot 8,18 \cdot (1 - 0,1)} - 0 = 69.64 \text{ bar}$$

ASME Section VIII Division 1 UG-81(a) Out-of-Roundness
Inside surface shall not deviate outside the shape by more than 1,25 % of D
Inside surface shall not deviate inside the shape by more than 0,625 % of D

Air Outlet (N2)

ASME Section VIII Division 1, 2021 Edition Metric

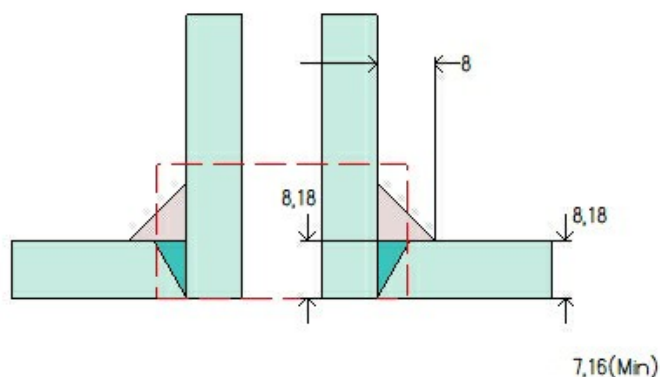

Note: round inside edges per UG-76(c)

Location and Orientation

Located on	B16.9 Pipe Cap - Right Side
Orientation	0°
End of nozzle to datum line	-230 mm
Calculated as hillside	No
Distance to head center, R	0 mm
Passes through a Category A joint	No

Nozzle

Description	NPS 0,75 XXS DN 20
Access opening	No
Material specification	SA-106 B Smls Pipe (II-D Metric p. 16, In. 16)
Inside diameter, new	11,02 mm
Pipe nominal wall thickness	7,82 mm
Pipe minimum wall thickness ¹	6,85 mm
Corrosion allowance	3 mm
Projection available outside vessel, L _{pr}	64,93 mm
Projection available outside vessel to flange face, L _f	128,43 mm
Local vessel minimum thickness	7,16 mm
Liquid static head included	0 bar

Welds

Inner fillet, Leg ₄₁	8 mm
Nozzle to vessel groove weld	8,18 mm

Radiography

Longitudinal seam	Seamless No RT
Circumferential seam	Full UW-11(a) Type 1

¹Pipe minimum thickness = nominal thickness times pipe tolerance factor of 0,875.

ASME B16.5-2017 Flange	
Description	NPS 0,75 Class 600 WN A105
Bolt Material	SA-193 B7 Bolt <= 64 (II-D Metric p. 410, ln. 32)
Blind included	No
Rated MDMT	-48°C
Liquid static head	0 bar
MAWP rating	88,9 bar @ 175°C
MAP rating	102,1 bar @ 21,11°C
Hydrotest rating	154 bar @ 21,11°C
PWHT performed	No
Produced to Fine Grain Practice and Supplied in Heat Treated Condition	No
Impact Tested	No
Circumferential joint radiography	Full UW-11(a) Type 1
Bore diameter, B (specified by purchaser)	11,02 mm
Gasket	
Type	ASME B16.20 Spiral-Wound
Description	Garlock FLEXSEAL RW 316L SS / Flexible Graphite
Factor, m	3
Seating Stress, y	703,07 kgf/cm ²
Thickness, T	3 mm
Inner Diameter	25,4 mm
Outer Diameter	39,6 mm
Notes	
Flange rated MDMT per UCS-66(b)(1)(b) = -48°C (Coincident ratio = 0,3786) Bolts rated MDMT per Fig UCS-66 note (c) = -48°C	

UCS-66 Material Toughness Requirements Nozzle	
$t_r = \frac{38,66-8,51}{1.180 \cdot 1 - 0,6 \cdot 38,66} =$	0,28 mm
Stress ratio = $\frac{t_r \cdot E^*}{t_n - c} = \frac{0,28 \cdot 1}{6,85-3} =$	0,074
Stress ratio ≤ 0,35, MDMT per UCS-66(b)(3) =	-105°C
Material is exempt from impact testing at the Design MDMT of 0°C.	

Reinforcement Calculations for Internal Pressure

UG-37 Area Calculation Summary (cm ²)							UG-45 Summary (mm)	
For P = 30,5 bar @ 175 °C							The nozzle passes UG-45	
A required	A available	A ₁	A ₂	A ₃	A ₅	A welds	t _{req}	t _{min}
This nozzle is exempt from area calculations per UG-36(c)(3)(a)							5,51	6,85

UG-41 Weld Failure Path Analysis Summary
The nozzle is exempt from weld strength calculations per UW-15(b)(2)

UW-16 Weld Sizing Summary			
Weld description	Required weld throat size (mm)	Actual weld throat size (mm)	Status
Nozzle to shell fillet (Leg ₄₁)	3,38	5,6	weld size is adequate

Calculations for internal pressure 30,5 bar @ 175 °C

Parallel Limit of reinforcement per UG-40

$$\begin{aligned}
 L_R &= \max [d, R_n + (t_n - C_n) + (t - C)] \\
 &= \max [17,02, 8,51 + (7,82 - 3) + (7,16 - 3)] \\
 &= 17,49 \text{ mm}
 \end{aligned}$$

Outer Normal Limit of reinforcement per UG-40

$$\begin{aligned}
 L_H &= \min [2,5 \cdot (t - C), 2,5 \cdot (t_n - C_n) + t_e] \\
 &= \min [2,5 \cdot (7,16 - 3), 2,5 \cdot (7,82 - 3) + 0] \\
 &= 10,39 \text{ mm}
 \end{aligned}$$

Nozzle required thickness per UG-27(c)(1)

$$\begin{aligned}
 t_{rn} &= \frac{P \cdot R_n}{S_n \cdot E - 0,6 \cdot P} \\
 &= \frac{30,5001 \cdot 8,51}{1,180 \cdot 1 - 0,6 \cdot 30,5001} \\
 &= 0,22 \text{ mm}
 \end{aligned}$$

Required thickness t_r from UG-37(a)(c)

$$\begin{aligned}
 t_r &= \frac{P \cdot K_1 \cdot D_o}{2 \cdot S \cdot E + 0,8 \cdot P} \\
 &= \frac{30,5001 \cdot 0,8749 \cdot 219,07}{2 \cdot 1,180 \cdot 1 + 0,8 \cdot 30,5001} \\
 &= 2,45 \text{ mm}
 \end{aligned}$$

Required thickness t_r per Interpretation VIII-1-07-50

$$t_r = \frac{P \cdot D_o \cdot K}{2 \cdot S \cdot E + 2 \cdot P \cdot (K - 0,1)} = \frac{30,5 \cdot 219,07 \cdot 0,963264}{2 \cdot 1,180 \cdot 0,85 + 2 \cdot 30,5 \cdot (0,963264 - 0,1)} = 3,13 \text{ mm}$$

This opening does not require reinforcement per UG-36(c)(3)(a)

UW-16(c) Weld Check

Fillet weld: $t_{\min} = \min [19\text{mm}, t_n, t] = 4,82 \text{ mm}$

$$t_{c(\min)} = \min [6 \text{ mm}, 0,7 \cdot t_{\min}] = \underline{3,38} \text{ mm}$$

$$t_{c(\text{actual})} = 0,7 \cdot \text{Leg} = 0,7 \cdot 8 = 5,6 \text{ mm}$$

The fillet weld size is satisfactory.

Weld strength calculations are not required for this detail which conforms to Fig. UW-16.1, sketch (c-e).

UG-45 Nozzle Neck Thickness Check

Interpretation VIII-1-83-66 has been applied.

$$\begin{aligned} t_{aUG-27} &= \frac{P \cdot R_n}{S_n \cdot E - 0,6 \cdot P} + \text{Corrosion} \\ &= \frac{30,5001 \cdot 8,51}{1.180 \cdot 1 - 0,6 \cdot 30,5001} + 3 \\ &= 3,22 \text{ mm} \end{aligned}$$

$$\begin{aligned} t_a &= \max [t_{aUG-27}, t_{aUG-22}] \\ &= \max [3,22, 0] \\ &= 3,22 \text{ mm} \end{aligned}$$

$$\begin{aligned} t_{b1} &= \frac{P \cdot D_o \cdot K}{2 \cdot S \cdot E + 2 \cdot P \cdot (K - 0,1)} + \text{Corrosion} \\ &= \frac{30,5 \cdot 219,07 \cdot 0,963264}{2 \cdot 1.180 \cdot 1 + 2 \cdot 30,5 \cdot (0,963264 - 0,1)} + 3 \\ &= 5,67 \text{ mm} \end{aligned}$$

$$\begin{aligned} t_{b1} &= \max [t_{b1}, t_{bUG16}] \\ &= \max [5,67, 4,5] \\ &= 5,67 \text{ mm} \end{aligned}$$

$$\begin{aligned} t_b &= \min [t_{b3}, t_{b1}] \\ &= \min [5,51, 5,67] \\ &= 5,51 \text{ mm} \end{aligned}$$

$$\begin{aligned} t_{UG-45} &= \max [t_a, t_b] \\ &= \max [3,22, 5,51] \\ &= \underline{5,51} \text{ mm} \end{aligned}$$

Available nozzle wall thickness new, $t_n = 0,875 \cdot 7,82 = 6,85 \text{ mm}$

The nozzle neck thickness is adequate.

Reinforcement Calculations for MAWP

The vessel wall thickness governs the MAWP of this nozzle.

UG-37 Area Calculation Summary (cm ²)						UG-45 Summary (mm)		
For P = 52,1 bar @ 175 °C						The nozzle passes UG-45		
A required	A available	A ₁	A ₂	A ₃	A ₅	A welds	t _{req}	t _{min}
This nozzle is exempt from area calculations per UG-36(c)(3)(a)						5,51	6,85	

UG-41 Weld Failure Path Analysis Summary
The nozzle is exempt from weld strength calculations per UW-15(b)(2)

UW-16 Weld Sizing Summary			
Weld description	Required weld throat size (mm)	Actual weld throat size (mm)	Status
Nozzle to shell fillet (Leg ₄₁)	3,38	5,6	weld size is adequate

Calculations for internal pressure 52,1 bar @ 175 °C

Parallel Limit of reinforcement per UG-40

$$\begin{aligned}
 L_R &= \max [d, R_n + (t_n - C_n) + (t - C)] \\
 &= \max [17,02, 8,51 + (7,82 - 3) + (7,16 - 3)] \\
 &= 17,49 \text{ mm}
 \end{aligned}$$

Outer Normal Limit of reinforcement per UG-40

$$\begin{aligned}
 L_H &= \min [2,5 \cdot (t - C), 2,5 \cdot (t_n - C_n) + t_e] \\
 &= \min [2,5 \cdot (7,16 - 3), 2,5 \cdot (7,82 - 3) + 0] \\
 &= 10,39 \text{ mm}
 \end{aligned}$$

Nozzle required thickness per UG-27(c)(1)

$$\begin{aligned}
 t_{rn} &= \frac{P \cdot R_n}{S_n \cdot E - 0,6 \cdot P} \\
 &= \frac{52,1004 \cdot 8,51}{1.180 \cdot 1 - 0,6 \cdot 52,1004} \\
 &= 0,39 \text{ mm}
 \end{aligned}$$

Required thickness t_r from UG-37(a)(c)

$$\begin{aligned}
 t_r &= \frac{P \cdot K_1 \cdot D_o}{2 \cdot S \cdot E + 0,8 \cdot P} \\
 &= \frac{52,1004 \cdot 0,8749 \cdot 219,07}{2 \cdot 1.180 \cdot 1 + 0,8 \cdot 52,1004} \\
 &= 4,16 \text{ mm}
 \end{aligned}$$

Required thickness t_r per Interpretation VIII-1-07-50

$$t_r = \frac{P \cdot D_o \cdot K}{2 \cdot S \cdot E + 2 \cdot P \cdot (K - 0,1)} = \frac{52,1 \cdot 219,07 \cdot 0,963264}{2 \cdot 1.180 \cdot 0,85 + 2 \cdot 52,1 \cdot (0,963264 - 0,1)} = 5,25 \text{ mm}$$

This opening does not require reinforcement per UG-36(c)(3)(a)

UW-16(c) Weld Check

Fillet weld: $t_{\min} = \min [19\text{mm}, t_n, t] = 4,82 \text{ mm}$

$t_{c(\min)} = \min [6 \text{ mm}, 0,7 \cdot t_{\min}] = 3,38 \text{ mm}$

$t_{c(\text{actual})} = 0,7 \cdot \text{Leg} = 0,7 \cdot 8 = 5,6 \text{ mm}$

The fillet weld size is satisfactory.

Weld strength calculations are not required for this detail which conforms to Fig. UW-16.1, sketch (c-e).

UG-45 Nozzle Neck Thickness Check

Interpretation VIII-1-83-66 has been applied.

$$\begin{aligned} t_{aUG-27} &= \frac{P \cdot R_n}{S_n \cdot E - 0,6 \cdot P} + \text{Corrosion} \\ &= \frac{52,1004 \cdot 8,51}{1.180 \cdot 1 - 0,6 \cdot 52,1004} + 3 \\ &= 3,39 \text{ mm} \end{aligned}$$

$$\begin{aligned} t_a &= \max [t_{aUG-27}, t_{aUG-22}] \\ &= \max [3,39, 0] \\ &= 3,39 \text{ mm} \end{aligned}$$

$$\begin{aligned} t_{b1} &= \frac{P \cdot D_o \cdot K}{2 \cdot S \cdot E + 2 \cdot P \cdot (K - 0,1)} + \text{Corrosion} \\ &= \frac{52,1 \cdot 219,07 \cdot 0,963264}{2 \cdot 1.180 \cdot 1 + 2 \cdot 52,1 \cdot (0,963264 - 0,1)} + 3 \\ &= 7,49 \text{ mm} \end{aligned}$$

$$\begin{aligned} t_{b1} &= \max [t_{b1}, t_{bUG16}] \\ &= \max [7,49, 4,5] \\ &= 7,49 \text{ mm} \end{aligned}$$

$$\begin{aligned} t_b &= \min [t_{b3}, t_{b1}] \\ &= \min [5,51, 7,49] \\ &= 5,51 \text{ mm} \end{aligned}$$

$$\begin{aligned} t_{UG-45} &= \max [t_a, t_b] \\ &= \max [3,39, 5,51] \\ &= 5,51 \text{ mm} \end{aligned}$$

Available nozzle wall thickness new, $t_n = 0,875 \cdot 7,82 = 6,85 \text{ mm}$

The nozzle neck thickness is adequate.

Reinforcement Calculations for MAP

The vessel wall thickness governs the MAP of this nozzle.

UG-37 Area Calculation Summary (cm ²)							UG-45 Summary (mm)	
For P = 88,24 bar @ 21,11 °C							The nozzle passes UG-45	
A required	A available	A ₁	A ₂	A ₃	A ₅	A welds	t _{req}	t _{min}
This nozzle is exempt from area calculations per UG-36(c)(3)(a)							2,51	6,85

UG-41 Weld Failure Path Analysis Summary
The nozzle is exempt from weld strength calculations per UW-15(b)(2)

Calculations for internal pressure 88,24 bar @ 21,11 °C

Parallel Limit of reinforcement per UG-40

$$\begin{aligned}
 L_R &= \max [d, R_n + (t_n - C_n) + (t - C)] \\
 &= \max [11,02, 5,51 + (7,82 - 0) + (7,16 - 0)] \\
 &= 20,49 \text{ mm}
 \end{aligned}$$

Outer Normal Limit of reinforcement per UG-40

$$\begin{aligned}
 L_H &= \min [2,5 \cdot (t - C), 2,5 \cdot (t_n - C_n) + t_e] \\
 &= \min [2,5 \cdot (7,16 - 0), 2,5 \cdot (7,82 - 0) + 0] \\
 &= 17,89 \text{ mm}
 \end{aligned}$$

Nozzle required thickness per UG-27(c)(1)

$$\begin{aligned}
 t_{rn} &= \frac{P \cdot R_n}{S_n \cdot E - 0,6 \cdot P} \\
 &= \frac{88,2375 \cdot 5,51}{1.180 \cdot 1 - 0,6 \cdot 88,2375} \\
 &= 0,43 \text{ mm}
 \end{aligned}$$

Required thickness t_r from UG-37(a)(c)

$$\begin{aligned}
 t_r &= \frac{P \cdot K_1 \cdot D_o}{2 \cdot S \cdot E + 0,8 \cdot P} \\
 &= \frac{88,2375 \cdot 0,9 \cdot 219,07}{2 \cdot 1.180 \cdot 1 + 0,8 \cdot 88,2375} \\
 &= 7,16 \text{ mm}
 \end{aligned}$$

Required thickness t_r per Interpretation VIII-1-07-50

$$t_r = \frac{P \cdot D_o \cdot K}{2 \cdot S \cdot E + 2 \cdot P \cdot (K - 0,1)} = \frac{88,24 \cdot 219,07 \cdot 1}{2 \cdot 1.180 \cdot 0,85 + 2 \cdot 88,24 \cdot (1 - 0,1)} = 8,93 \text{ mm}$$

This opening does not require reinforcement per UG-36(c)(3)(a)

UG-45 Nozzle Neck Thickness Check

Interpretation VIII-1-83-66 has been applied.

$$\begin{aligned}t_{aUG-27} &= \frac{P \cdot R_n}{S_n \cdot E - 0,6 \cdot P} + \text{Corrosion} \\ &= \frac{88,2375 \cdot 5,51}{1.180 \cdot 1 - 0,6 \cdot 88,2375} + 0 \\ &= 0,43 \text{ mm}\end{aligned}$$

$$\begin{aligned}t_a &= \max [t_{aUG-27}, t_{aUG-22}] \\ &= \max [0,43, 0] \\ &= 0,43 \text{ mm}\end{aligned}$$

$$\begin{aligned}t_{b1} &= \frac{P \cdot D_o \cdot K}{2 \cdot S \cdot E + 2 \cdot P \cdot (K - 0,1)} + \text{Corrosion} \\ &= \frac{88,24 \cdot 219,07 \cdot 1}{2 \cdot 1.180 \cdot 1 + 2 \cdot 88,24 \cdot (1 - 0,1)} + 0 \\ &= 7,67 \text{ mm}\end{aligned}$$

$$\begin{aligned}t_{b1} &= \max [t_{b1}, t_{bUG16}] \\ &= \max [7,67, 1,5] \\ &= 7,67 \text{ mm}\end{aligned}$$

$$\begin{aligned}t_b &= \min [t_{b3}, t_{b1}] \\ &= \min [2,51, 7,67] \\ &= 2,51 \text{ mm}\end{aligned}$$

$$\begin{aligned}t_{UG-45} &= \max [t_a, t_b] \\ &= \max [0,43, 2,51] \\ &= 2,51 \text{ mm}\end{aligned}$$

Available nozzle wall thickness new, $t_n = 0,875 \cdot 7,82 = 6,85 \text{ mm}$

The nozzle neck thickness is adequate.

Locati Impianti Srl

Via Vittorio Veneto, 37 - Verdellino - Bergamo - Italy

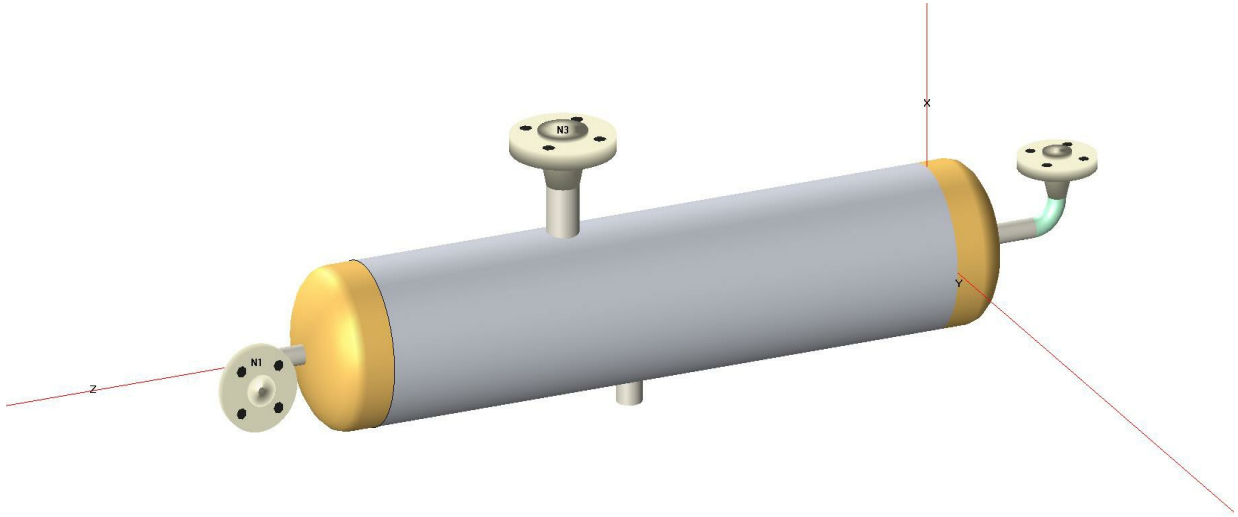

COMPRESS Pressure Vessel Design Calculations

Item: LI 5061

Customer: Airpack

Drawing No.: C230048DWG003

Document No.: C230048CLC007 Rev.04

Date: 04/10/2024

Service: 2nd Stage Inlet Pulsation Damper

Tag Number: 320-KV-020-003

Table of Contents

Nozzle Schedule	1
Nozzle Summary	2
Pressure Summary	3
Settings Summary	4
Radiography Summary	6
Thickness Summary	7
Weight Summary	8
Hydrostatic Test	9
B16.9 Pipe Cap - Left Side	10
Straight Flange on B16.9 Pipe Cap - Left Side	12
Air Inlet (N1)	14
B16.9 Elbow #1 (N1)	22
Cylinder #1	25
Temperature Transmitter Connection (N3)	27
Drain (N4)	37
Straight Flange on B16.9 Pipe Cap - Right Side	44
B16.9 Pipe Cap - Right Side	46
Air Outlet (N2)	48
B16.9 Elbow #2 (N2)	56

Nozzle Schedule

Specifications									
Nozzle mark	Identifier	Size	Materials		Impact Tested	Normalized	Fine Grain	Flange	Blind
N1	Air Inlet	NPS 0,75 XXS DN 20	Nozzle	SA-106 B Smls Pipe	No	No	No	N/A	No
	B16.9 Elbow #1 (N1)	NPS 0,75 XXS DN 20	B16.9 Elbow	SA-234 WPB	No	No	No	NPS 3/4 Class 600 WN A105	No
N2	Air Outlet	NPS 0,75 XXS DN 20	Nozzle	SA-106 B Smls Pipe	No	No	No	N/A	No
	B16.9 Elbow #2 (N2)	NPS 0,75 XXS DN 20	B16.9 Elbow	SA-234 WPB	No	No	No	NPS 3/4 Class 600 WN A105	No
N3	Temperature Transmitter Connection	NPS 1,5 Sch 160 DN 40	Nozzle	SA-106 B Smls Pipe	No	No	No	NPS 1 1/2 Class 600 WN A105	No
N4	Drain	NPS 0,5 Class 6000 DN 15 - Threaded Full Coupling	Nozzle	SA-105	No	No	No	N/A	No

Nozzle Summary

Dimensions												
Nozzle mark	OD (mm)	t _n (mm)	Req t _n (mm)	A ₁ ?	A ₂ ?	Shell			Reinforcement Pad		Corr (mm)	A _a /A _r (%)
						Nom t (mm)	Design t (mm)	User t (mm)	Width (mm)	t _{pad} (mm)		
N1	26,67	7,82	6,3	Yes	Yes	12,7	N/A		N/A	N/A	3	Exempt
N2	26,67	7,82	6,3	Yes	Yes	12,7	N/A		N/A	N/A	3	Exempt
N3	48,26	7,14	7,11	Yes	Yes	12,7	N/A		N/A	N/A	3	Exempt
N4	38,1	8,38	4,5	Yes	Yes	12,7	N/A		N/A	N/A	3	Exempt

*Head minimum thickness after forming

Definitions	
t _n	Nozzle thickness
Req t _n	Nozzle thickness required per UG-45/UG-16 Increased for pipe to account for 12.5% pipe thickness tolerance
Nom t	Vessel wall thickness
Design t	Required vessel wall thickness due to pressure + corrosion allowance per UG-37
User t	Local vessel wall thickness (near opening)
A _a	Area available per UG-37, governing condition
A _r	Area required per UG-37, governing condition
Corr	Corrosion allowance on nozzle wall

Pressure Summary

Component Summary							
Identifier	P Design (bar)	T Design (°C)	MAWP (bar)	MAP (bar)	MDMT (°C)	MDMT Exemption	Impact Tested
B16.9 Pipe Cap - Left Side	39	157	82,74	111,98	-48	Note 1	No
Straight Flange on B16.9 Pipe Cap - Left Side	39	157	92,09	121,95	-48	Note 2	No
Cylinder #1	39	157	76,56	106,06	-48	Note 3	No
Straight Flange on B16.9 Pipe Cap - Right Side	39	157	92,09	121,95	-48	Note 2	No
B16.9 Pipe Cap - Right Side	39	157	82,74	111,98	-48	Note 4	No
Air Inlet (N1)	39	157	103,54	139,29	-105	Note 5	No
B16.9 Elbow #1 (N1)	39	157	89,84	102,1	-48	Note 6, 7	No
Air Outlet (N2)	39	157	103,54	139,29	-105	Note 5	No
B16.9 Elbow #2 (N2)	39	157	89,84	102,1	-48	Note 6, 7	No
Temperature Transmitter Connection (N3)	39	157	89,84	102,1	-48	Note 8	No
Drain (N4)	39	157	90,07	124,78	-105	Note 9	No

Chamber Summary	
Design MDMT	0 °C
Rated MDMT	0 °C @ 40,92 bar
MAWP hot & corroded	40,92 bar @ 157 °C
MAP cold & new	102,1 bar @ 21,11 °C
(1) The MAWP is limited due to the MAWP limit set in the Calculations tab of the Set Mode dialog. (2) The rated MDMT is limited to the design MDMT based on the setting in the Calculations tab of the Set Mode dialog. (3) This pressure chamber is not designed for external pressure.	

Notes for MDMT Rating		
Note #	Exemption	Details
1.	Straight Flange governs MDMT	
2.	Material impact test exemption temperature from Fig UCS-66M Curve B = -24,98°C Fig UCS-66.1M MDMT reduction = 57,6°C, (coincident ratio = 0,3853) Rated MDMT of -82,58°C is limited to -48°C by UCS-66(b)(2)	UCS-66 governing thickness = 11,11 mm
3.	Material impact test exemption temperature from Fig UCS-66M Curve B = -24,98°C Fig UCS-66.1M MDMT reduction = 36,9°C, (coincident ratio = 0,4607) Rated MDMT of -61,88°C is limited to -48°C by UCS-66(b)(2)	UCS-66 governing thickness = 11,11 mm
4.	Straight Flange governs MDMT	
5.	Nozzle is impact test exempt to -105°C per UCS-66(b)(3) (coincident ratio = 0,0784).	
6.	Material is impact test exempt to -105°C per UCS-66(b)(3) (coincident ratio = 0,1182)	
7.	Flange rating governs: Flange rated MDMT per UCS-66(b)(1)(b) = -48°C (Coincident ratio = 0,4008)	Bolts rated MDMT per Fig UCS-66 note (c) = -48°C
8.	Flange rating governs: Flange rated MDMT per UCS-66(b)(1)(b) = -48°C (Coincident ratio = 0,4008) Bolts rated MDMT per Fig UCS-66 note (c) = -48°C	
9.	Nozzle is impact test exempt to -105°C per UCS-66(b)(3) (coincident ratio = 0,0767).	

Settings Summary

COMPRESS 2024 Build 8400	
ASME Section VIII Division 1, 2021 Edition Metric	
Units	MKS
Datum Line Location	0,00 mm from right seam
Vessel Design Mode	Design Mode
Minimum thickness	1,5 mm per UG-16(b)
Design for cold shut down only	No
Design for lethal service (full radiography required)	No
User has limited MAWP to	40,92 bar
Design nozzles for	Design P only
Corrosion weight loss	100% of theoretical loss
UG-23 Stress Increase	1,20
Skirt/legs stress increase	1,0
Minimum nozzle projection	60 mm
Juncture calculations for $\alpha > 30$ only	Yes
Preheat P-No 1 Materials > 1,25" and <= 1,50" thick	No
UG-37(a) shell tr calculation considers longitudinal stress	No
Cylindrical shells made from pipe are entered as minimum thickness	No
Nozzles made from pipe are entered as minimum thickness	No
ASME B16.9 fittings are entered as minimum thickness	No
Butt welds	Tapered per Figure UCS-66.3(a)
Disallow Appendix 1-5, 1-8 calculations under 15 psi	No
Hydro/Pneumatic Test	
Shop Hydrotest Pressure	1,3 times vessel MAWP [UG-99(b)]
Test liquid specific gravity	1,00
Maximum stress during test	90% of yield
Required Marking - UG-116	
UG-116(e) Radiography	RT3
UG-116(f) Postweld heat treatment	None
Code Cases\Interpretations	
Use Appendix 46	No
Use UG-44(b)	No
Use Code Case 3035	No
Apply interpretation VIII-1-83-66	Yes
Apply interpretation VIII-1-86-175	Yes
Apply interpretation VIII-1-01-37	Yes
Apply interpretation VIII-1-01-150	Yes
Apply interpretation VIII-1-07-50	Yes
Apply interpretation VIII-1-16-85	Yes
No UCS-66.1 MDMT reduction	No
No UCS-68(c) MDMT reduction	No
Disallow UG-20(f) exemptions	No
UG-22 Loadings	
UG-22(a) Internal or External Design Pressure	Yes
UG-22(b) Weight of the vessel and normal contents under operating or test conditions	No
UG-22(c) Superimposed static reactions from weight of attached equipment (external loads)	No
UG-22(d)(2) Vessel supports such as lugs, rings, skirts, saddles and legs	No
UG-22(f) Wind reactions	No
UG-22(f) Seismic reactions	No

UG-22(j) Test pressure and coincident static head acting during the test:	No
Note: UG-22(b),(c) and (f) loads only considered when supports are present.	
Note 2: UG-22(d)(1),(e),(f)-snow,(g),(h),(i) are not considered. If these loads are present, additional calculations must be performed.	

License Information	
Company Name	Locati Impianti s.r.l.
License	Commercial
License Key ID	32235
Support Expires	September 20, 2025
Account Number	891888909529634

Radiography Summary

UG-116 Radiography							
Component	Longitudinal Seam		Left Circumferential Seam		Right Circumferential Seam		Mark
	Category (Fig UW-3)	Radiography / Joint Type	Category (Fig UW-3)	Radiography / Joint Type	Category (Fig UW-3)	Radiography / Joint Type	
B16.9 Pipe Cap - Left Side	N/A	Seamless No RT	N/A	N/A	B	Spot UW-11(b) / Type 1	RT3
Cylinder #1	N/A	Seamless No RT	B	Spot UW-11(b) / Type 1	B	Spot UW-11(b) / Type 1	RT3
B16.9 Pipe Cap - Right Side	N/A	Seamless No RT	B	Spot UW-11(b) / Type 1	N/A	N/A	RT3
Nozzle	Longitudinal Seam		Nozzle to Vessel Circumferential Seam		Nozzle free end Circumferential Seam		
Air Inlet (N1)	N/A	Seamless No RT	D	N/A / Type 7	B	UW-11(b) exempt / Type 1	N/A
B16.9 Elbow #1 (N1)	N/A	Seamless No RT	B	UW-11(b) exempt / Type 1	C	UW-11(b) exempt / Type 1	N/A
Temperature Transmitter Connection (N3)	N/A	Seamless No RT	D	N/A / Type 7	C	UW-11(b) exempt / Type 1	N/A
Drain (N4)	N/A	Seamless No RT	D	N/A / Type 7	N/A	N/A	N/A
Air Outlet (N2)	N/A	Seamless No RT	D	N/A / Type 7	B	UW-11(b) exempt / Type 1	N/A
B16.9 Elbow #2 (N2)	N/A	Seamless No RT	B	UW-11(b) exempt / Type 1	C	UW-11(b) exempt / Type 1	N/A
Nozzle Flange	Longitudinal Seam		Flange Face		Nozzle to Flange Circumferential Seam		
ASME B16.5/16.47 flange attached to right end of B16.9 Elbow #1 (N1)	N/A	Seamless No RT	N/A	N/A / Gasketed	C	UW-11(b) exempt / Type 1	N/A
ASME B16.5/16.47 flange attached to Temperature Transmitter Connection (N3)	N/A	Seamless No RT	N/A	N/A / Gasketed	C	UW-11(b) exempt / Type 1	N/A
ASME B16.5/16.47 flange attached to right end of B16.9 Elbow #2 (N2)	N/A	Seamless No RT	N/A	N/A / Gasketed	C	UW-11(b) exempt / Type 1	N/A
UG-116(e) Required Marking: RT3							

Thickness Summary

Component Data								
Component Identifier	Material	Diameter (mm)	Length (mm)	Nominal t (mm)	Design t (mm)	Total Corrosion (mm)	Joint E	Load
B16.9 Pipe Cap - Left Side	SA-234 WPB	219,07 OD	59,53	12,7	6,96	3	0,85	Internal
Straight Flange on B16.9 Pipe Cap - Left Side	SA-234 WPB	219,07 OD	42,47	12,7	7,2	3	0,85	Internal
Cylinder #1	SA-106 B Smls Pipe	219,07 OD	890	12,7	7,2	3	0,85	Internal
Straight Flange on B16.9 Pipe Cap - Right Side	SA-234 WPB	219,07 OD	42,47	12,7	7,2	3	0,85	Internal
B16.9 Pipe Cap - Right Side	SA-234 WPB	219,07 OD	59,53	12,7	6,96	3	0,85	Internal

Definitions	
Nominal t	Vessel wall nominal thickness
Design t	Required vessel thickness due to governing loading + corrosion
Joint E	Longitudinal seam joint efficiency
Load	
Internal	Circumferential stress due to internal pressure governs
External	External pressure governs
Wind	Combined longitudinal stress of pressure + weight + wind governs
Seismic	Combined longitudinal stress of pressure + weight + seismic governs

Weight Summary

Weight (kg) Contributed by Vessel Elements											
Component	Metal New*	Metal Corroded	Insulation	Insulation Supports	Lining	Piping + Liquid	Operating Liquid		Test Liquid		Surface Area m ²
							New	Corroded	New	Corroded	
B16.9 Pipe Cap - Left Side	7,7	6,1	0	0	0	0	0	0	2,2	2,4	0,09
Cylinder #1	57,1	44,3	0	0	0	0	0	0	26,3	27,9	0,61
B16.9 Pipe Cap - Right Side	7,7	6,1	0	0	0	0	0	0	2,2	2,4	0,09
TOTAL:	72,6	56,4	0	0	0	0	0	0	30,7	32,8	0,78

*Shells with attached nozzles have weight reduced by material cut out for opening.

Weight (kg) Contributed by Attachments										
Component	Body Flanges		Nozzles & Flanges		Packed Beds	Trays	Tray Supports	Rings & Clips	Vertical Loads	Surface Area m ²
	New	Corroded	New	Corroded						
B16.9 Pipe Cap - Left Side	0	0	2,3	2,2	0	0	0	0	0	0,03
Cylinder #1	0	0	4,5	4,2	0	0	0	0	0	0,06
B16.9 Pipe Cap - Right Side	0	0	2,3	2,2	0	0	0	0	0	0,03
TOTAL:	0	0	9,1	8,5	0	0	0	0	0	0,13

Vessel Totals		
	New	Corroded
Operating Weight (kg)	82	65
Empty Weight (kg)	82	65
Test Weight (kg)	112	98
Surface Area (m ²)	0,91	-
Capacity** (liters)	31	33

**The vessel capacity does not include volume of nozzle, piping or other attachments.

Vessel Lift Condition	
Vessel Lift Weight, New (kg)	82
Center of Gravity from Datum (mm)	452,08

Hydrostatic Test

Horizontal shop hydrostatic test based on MAWP per UG-99(b)

$$\begin{aligned}
 \text{Gauge pressure at } 21,11^{\circ}\text{C} &= 1,3 \cdot MAWP \cdot LSR \\
 &= 1,3 \cdot 40,92 \cdot 1 \\
 &= 53,2 \text{ bar}
 \end{aligned}$$

Horizontal shop hydrostatic test				
Identifier	Local test pressure (bar)	Test liquid static head (bar)	UG-99(b) stress ratio	UG-99(b) pressure factor
B16.9 Pipe Cap - Left Side (1)	53,23	0,03	1	1,30
Straight Flange on B16.9 Pipe Cap - Left Side	53,23	0,03	1	1,30
Cylinder #1	53,23	0,03	1	1,30
Straight Flange on B16.9 Pipe Cap - Right Side	53,23	0,03	1	1,30
B16.9 Pipe Cap - Right Side	53,23	0,03	1	1,30
Air Inlet (N1)	53,22	0,03	1	1,30
Air Outlet (N2)	53,22	0,03	1	1,30
B16.9 Elbow #1 (N1)	53,22	0,03	1	1,30
B16.9 Elbow #2 (N2)	53,22	0,03	1	1,30
Drain (N4)	53,23	0,04	1	1,30
Temperature Transmitter Connection (N3)	53,21	0,01	1	1,30
(1) B16.9 Pipe Cap - Left Side limits the UG-99(b) stress ratio. (2) The zero degree angular position is assumed to be up, and the test liquid height is assumed to the top-most flange.				

The field test condition has not been investigated.

The test temperature of 21,11 °C is warmer than the minimum recommended temperature of -31 °C so the brittle fracture provision of UG-99(h) has been met.

B16.9 Pipe Cap - Left Side

ASME Section VIII Division 1, 2021 Edition Metric				
Component		ASME B16.9 Pipe Cap (modified)		
Material		SA-234 WPB (II-D Metric p. 16, In. 18)		
Attached To		Cylinder #1		
Impact Tested	Normalized	Fine Grain Practice	PWHT	Maximize MDMT/ No MAWP
No	No	No	No	No
		Design Pressure (bar)	Design Temperature (°C)	Design MDMT (°C)
Internal		39	157	0
Static Liquid Head				
Condition	P_s (bar)	H_s (mm)	SG	
Test horizontal	0,03	346,84	1	
Dimensions				
NPS and Schedule		NPS 8 Sch 80 (XS) DN 200		
Outer Diameter		219,07 mm		
Overall Length E		102 mm		
Nominal Thickness		12,7 mm		
Minimum Thickness¹		11,11 mm		
Corrosion	Inner	3 mm		
	Outer	0 mm		
Length L_{sf}		42,47 mm		
Nominal Thickness t_{sf}		12,7 mm		
Weight and Capacity				
		Weight (kg)²	Capacity (liters)²	
New		7,72	2,2	
Corroded		6,06	2,4	
Radiography				
Category A joints		Seamless No RT		
Head to shell seam		Spot UW-11(b) Type 1		

¹ minimum thickness = nominal thickness times pipe tolerance factor of 0,875.

² includes straight flange

Results Summary	
Governing condition	internal pressure
Minimum thickness per UG-16	1,5 mm + 3 mm = 4,5 mm
Design thickness due to internal pressure (t)	<u>6,96</u> mm
Governing straight flange design thickness	7,2 mm
Maximum allowable working pressure (MAWP)	<u>82,74</u> bar
Maximum allowable pressure (MAP)	<u>111,98</u> bar
<u>Straight Flange</u> governs MDMT	-48°C

Factor K		
	$K = \left(\frac{1}{6}\right) \cdot \left[2 + \left(\frac{D}{2 \cdot h}\right)^2\right]$	
Corroded	$K = \left(\frac{1}{6}\right) \cdot \left[2 + \left(\frac{199,67}{2 \cdot 51,42}\right)^2\right]$	0,9617
New	$K = \left(\frac{1}{6}\right) \cdot \left[2 + \left(\frac{193,67}{2 \cdot 48,42}\right)^2\right]$	1

Design thickness for internal pressure, (Corroded at 157 °C) Appendix 1-4(c)

$$t = \frac{P \cdot D_o \cdot K}{2 \cdot S \cdot E + 2 \cdot P \cdot (K - 0,1)} + \text{Corrosion} = \frac{39 \cdot 219,07 \cdot 0,961673}{2 \cdot 1.180 \cdot 0,85 + 2 \cdot 39 \cdot (0,961673 - 0,1)} + 3 = 6.96 \text{ mm}$$

Maximum allowable working pressure, (Corroded at 157 °C) Appendix 1-4(c)

$$P = \frac{2 \cdot S \cdot E \cdot t}{K \cdot D_o - 2 \cdot t \cdot (K - 0,1)} - P_s = \frac{2 \cdot 1.180 \cdot 0,85 \cdot (0,875 \cdot 12,7 - 3)}{0,961673 \cdot 219,07 - 2 \cdot (0,875 \cdot 12,7 - 3) \cdot (0,961673 - 0,1)} - 0 = 82.74 \text{ bar}$$

Maximum allowable pressure, (New at 21,11 °C) Appendix 1-4(c)

$$P = \frac{2 \cdot S \cdot E \cdot t}{K \cdot D_o - 2 \cdot t \cdot (K - 0,1)} - P_s = \frac{2 \cdot 1.180 \cdot 0,85 \cdot 0,875 \cdot 12,7}{1 \cdot 219,07 - 2 \cdot 0,875 \cdot 12,7 \cdot (1 - 0,1)} - 0 = 111.98 \text{ bar}$$

ASME Section VIII Division 1 UG-81(a) Out-of-Roundness
Inside surface shall not deviate outside the shape by more than 1,25 % of D
Inside surface shall not deviate inside the shape by more than 0,625 % of D

Straight Flange on B16.9 Pipe Cap - Left Side

ASME Section VIII Division 1, 2021 Edition Metric				
Component		Cylinder		
Material		SA-234 WPB (II-D Metric p. 16, ln. 18)		
Impact Tested	Normalized	Fine Grain Practice	PWHT	Maximize MDMT/ No MAWP
No	No	No	No	No
		Design Pressure (bar)	Design Temperature (°C)	Design MDMT (°C)
Internal		39	157	0
Static Liquid Head				
Condition		P_s (bar)	H_s (mm)	SG
Test horizontal		0,03	346,84	1
Dimensions				
Outer Diameter		219,07 mm		
Length		42,47 mm		
Nominal Thickness		12,7 mm		
Corrosion	Inner	3 mm		
	Outer	0 mm		
Weight and Capacity				
		Weight (kg)		Capacity (liters)
New		2,74		1,25
Corroded		2,12		1,33
Radiography				
Longitudinal seam		Seamless No RT		
Right Circumferential seam		Spot UW-11(b) Type 1		

Results Summary	
Governing condition	Internal pressure
Minimum thickness per UG-16	1,5 mm + 3 mm = 4,5 mm
Design thickness due to internal pressure (t)	7,2 mm
Maximum allowable working pressure (MAWP)	92,09 bar
Maximum allowable pressure (MAP)	121,95 bar
Rated MDMT	-48 °C

UCS-66 Material Toughness Requirements	
Governing thickness, t _g =	11,11 mm
Exemption temperature from Fig UCS-66M Curve B =	-24,98°C
$t_r = \frac{40,92 \cdot 109,54}{1,180 \cdot 0,85 + 0,4 \cdot 40,92} =$	4,4 mm
Stress ratio = $\frac{t_r \cdot E^*}{t_n - c} = \frac{4,4 \cdot 0,85}{12,7 - 3} =$	0,3853
Reduction in MDMT, T _R from Fig UCS-66.1M =	57,6°C
$MDMT = \max [MDMT - T_R, -48] = \max [-24,98 - 57,6, -48] =$	-48°C
Material is exempt from impact testing at the Design MDMT of 0°C.	

Design thickness, (at 157 °C) Appendix 1-1

$$t = \frac{P \cdot R_o}{S \cdot E + 0,40 \cdot P} + \text{Corrosion} = \frac{39 \cdot 109,54}{1.180 \cdot 0,85 + 0,40 \cdot 39} + 3 = \underline{7,2} \text{ mm}$$

Maximum allowable working pressure, (at 157 °C) Appendix 1-1

$$P = \frac{S \cdot E \cdot t}{R_o - 0,40 \cdot t} - P_s = \frac{1.180 \cdot 0,85 \cdot 9,7}{109,54 - 0,40 \cdot 9,7} - 0 = \underline{92,09} \text{ bar}$$

Maximum allowable pressure, (at 21,11 °C) Appendix 1-1

$$P = \frac{S \cdot E \cdot t}{R_o - 0,40 \cdot t} = \frac{1.180 \cdot 0,85 \cdot 12,7}{109,54 - 0,40 \cdot 12,7} = \underline{121,95} \text{ bar}$$

ASME Section VIII Division 1 UG-80(a) Out-of-Roundness
$(D_{\max} - D_{\min})$ shall not exceed 1% of D
When the cross section passes through an opening or within 1 I.D. of the opening, $(D_{\max} - D_{\min})$ shall not exceed 1% of $D + 2\%$ of the inside diameter of the opening

Air Inlet (N1)

ASME Section VIII Division 1, 2021 Edition Metric

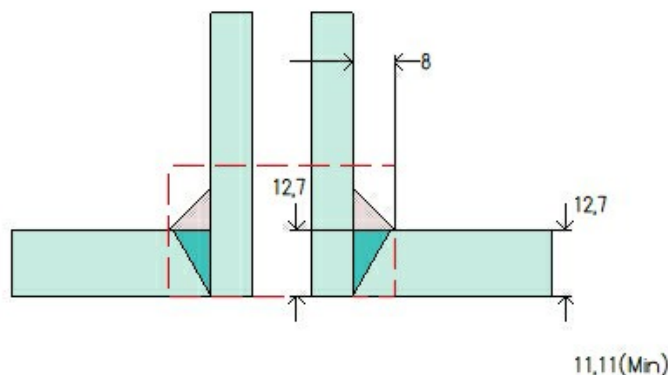

Note: round inside edges per UG-76(c)

Location and Orientation

Located on	B16.9 Pipe Cap - Left Side
Orientation	0°
End of nozzle to datum line	1.056 mm
Calculated as hillside	No
Distance to head center, R	0 mm
Passes through a Category A joint	No

Nozzle

Description	NPS 0,75 XXS DN 20
Access opening	No
Material specification	SA-106 B Smls Pipe (II-D Metric p. 16, In. 16)
Inside diameter, new	11,02 mm
Pipe nominal wall thickness	7,82 mm
Pipe minimum wall thickness ¹	6,85 mm
Corrosion allowance	3 mm
Projection available outside vessel, L _{pr}	64,44 mm
Local vessel minimum thickness	11,11 mm
Liquid static head included	0 bar

Welds

Inner fillet, Leg ₄₁	8 mm
Nozzle to vessel groove weld	12,7 mm

Radiography

Longitudinal seam	Seamless No RT
Circumferential seam	Full UW-11(a) Type 1

¹Pipe minimum thickness = nominal thickness times pipe tolerance factor of 0,875.

UCS-66 Material Toughness Requirements Nozzle

$t_r = \frac{40,92 \cdot 8,51}{1,180 \cdot 1 - 0,6 \cdot 40,92} =$	0,3 mm
Stress ratio $= \frac{t_r \cdot E^*}{t_n - c} = \frac{0,3 \cdot 1}{6,85 - 3} =$	0,0784
Stress ratio $\leq 0,35$, MDMT per UCS-66(b)(3) =	-105°C
Material is exempt from impact testing at the Design MDMT of 0°C.	

Reinforcement Calculations for Internal Pressure

UG-37 Area Calculation Summary (cm ²)							UG-45 Summary (mm)	
For P = 39 bar @ 157 °C							The nozzle passes UG-45	
A required	A available	A ₁	A ₂	A ₃	A ₅	A welds	t _{req}	t _{min}
This nozzle is exempt from area calculations per UG-36(c)(3)(a)							5,51	6,85

UG-41 Weld Failure Path Analysis Summary
The nozzle is exempt from weld strength calculations per UW-15(b)(2)

UW-16 Weld Sizing Summary			
Weld description	Required weld throat size (mm)	Actual weld throat size (mm)	Status
Nozzle to shell fillet (Leg ₄₁)	3,38	5,6	weld size is adequate

Calculations for internal pressure 39 bar @ 157 °C

Parallel Limit of reinforcement per UG-40

$$\begin{aligned}
 L_R &= \max [d, R_n + (t_n - C_n) + (t - C)] \\
 &= \max [17,02, 8,51 + (7,82 - 3) + (11,11 - 3)] \\
 &= 21,45 \text{ mm}
 \end{aligned}$$

Outer Normal Limit of reinforcement per UG-40

$$\begin{aligned}
 L_H &= \min [2,5 \cdot (t - C), 2,5 \cdot (t_n - C_n) + t_e] \\
 &= \min [2,5 \cdot (11,11 - 3), 2,5 \cdot (7,82 - 3) + 0] \\
 &= 12,06 \text{ mm}
 \end{aligned}$$

Nozzle required thickness per UG-27(c)(1)

$$\begin{aligned}
 t_{rn} &= \frac{P \cdot R_n}{S_n \cdot E - 0,6 \cdot P} \\
 &= \frac{39,0001 \cdot 8,51}{1,180 \cdot 1 - 0,6 \cdot 39,0001} \\
 &= 0,29 \text{ mm}
 \end{aligned}$$

Required thickness t_r from UG-37(a)(c)

$$\begin{aligned}
 t_r &= \frac{P \cdot K_1 \cdot D_o}{2 \cdot S \cdot E + 0,8 \cdot P} \\
 &= \frac{39,0001 \cdot 0,8737 \cdot 219,07}{2 \cdot 1,180 \cdot 1 + 0,8 \cdot 39,0001} \\
 &= 3,12 \text{ mm}
 \end{aligned}$$

Required thickness t_r per Interpretation VIII-1-07-50

$$t_r = \frac{P \cdot D_o \cdot K}{2 \cdot S \cdot E + 2 \cdot P \cdot (K - 0,1)} = \frac{39 \cdot 219,07 \cdot 0,961673}{2 \cdot 1,180 \cdot 0,85 + 2 \cdot 39 \cdot (0,961673 - 0,1)} = 3,96 \text{ mm}$$

This opening does not require reinforcement per UG-36(c)(3)(a)

UW-16(c) Weld Check

Fillet weld: $t_{\min} = \min [19\text{mm}, t_n, t] = 4,82 \text{ mm}$

$$t_{c(\min)} = \min [6 \text{ mm}, 0,7 \cdot t_{\min}] = \underline{3,38} \text{ mm}$$

$$t_{c(\text{actual})} = 0,7 \cdot \text{Leg} = 0,7 \cdot 8 = 5,6 \text{ mm}$$

The fillet weld size is satisfactory.

Weld strength calculations are not required for this detail which conforms to Fig. UW-16.1, sketch (c-e).

UG-45 Nozzle Neck Thickness Check

Interpretation VIII-1-83-66 has been applied.

$$\begin{aligned} t_{aUG-27} &= \frac{P \cdot R_n}{S_n \cdot E - 0,6 \cdot P} + \text{Corrosion} \\ &= \frac{39,0001 \cdot 8,51}{1.180 \cdot 1 - 0,6 \cdot 39,0001} + 3 \\ &= 3,29 \text{ mm} \end{aligned}$$

$$\begin{aligned} t_a &= \max [t_{aUG-27}, t_{aUG-22}] \\ &= \max [3,29, 0] \\ &= 3,29 \text{ mm} \end{aligned}$$

$$\begin{aligned} t_{b1} &= \frac{P \cdot D_o \cdot K}{2 \cdot S \cdot E + 2 \cdot P \cdot (K - 0,1)} + \text{Corrosion} \\ &= \frac{39 \cdot 219,07 \cdot 0,961673}{2 \cdot 1.180 \cdot 1 + 2 \cdot 39 \cdot (0,961673 - 0,1)} + 3 \\ &= 6,38 \text{ mm} \end{aligned}$$

$$\begin{aligned} t_{b1} &= \max [t_{b1}, t_{bUG16}] \\ &= \max [6,39, 4,5] \\ &= 6,39 \text{ mm} \end{aligned}$$

$$\begin{aligned} t_b &= \min [t_{b3}, t_{b1}] \\ &= \min [5,51, 6,39] \\ &= 5,51 \text{ mm} \end{aligned}$$

$$\begin{aligned} t_{UG-45} &= \max [t_a, t_b] \\ &= \max [3,29, 5,51] \\ &= \underline{5,51} \text{ mm} \end{aligned}$$

Available nozzle wall thickness new, $t_n = 0,875 \cdot 7,82 = 6,85 \text{ mm}$

The nozzle neck thickness is adequate.

Reinforcement Calculations for MAWP

The vessel wall thickness governs the MAWP of this nozzle.

UG-37 Area Calculation Summary (cm ²)							UG-45 Summary (mm)	
For P = 103,54 bar @ 157 °C							The nozzle passes UG-45	
A required	A available	A ₁	A ₂	A ₃	A ₅	A welds	t _{req}	t _{min}
This nozzle is exempt from area calculations per UG-36(c)(3)(a)							5,51	6,85

UG-41 Weld Failure Path Analysis Summary
The nozzle is exempt from weld strength calculations per UW-15(b)(2)

UW-16 Weld Sizing Summary			
Weld description	Required weld throat size (mm)	Actual weld throat size (mm)	Status
Nozzle to shell fillet (Leg ₄₁)	3,38	5,6	weld size is adequate

Calculations for internal pressure 103,54 bar @ 157 °C

Parallel Limit of reinforcement per UG-40

$$\begin{aligned}
 L_R &= \max [d, R_n + (t_n - C_n) + (t - C)] \\
 &= \max [17,02, 8,51 + (7,82 - 3) + (11,11 - 3)] \\
 &= 21,45 \text{ mm}
 \end{aligned}$$

Outer Normal Limit of reinforcement per UG-40

$$\begin{aligned}
 L_H &= \min [2,5 \cdot (t - C), 2,5 \cdot (t_n - C_n) + t_e] \\
 &= \min [2,5 \cdot (11,11 - 3), 2,5 \cdot (7,82 - 3) + 0] \\
 &= 12,06 \text{ mm}
 \end{aligned}$$

Nozzle required thickness per UG-27(c)(1)

$$\begin{aligned}
 t_{rn} &= \frac{P \cdot R_n}{S_n \cdot E - 0,6 \cdot P} \\
 &= \frac{103,5405 \cdot 8,51}{1.180 \cdot 1 - 0,6 \cdot 103,5405} \\
 &= 0,79 \text{ mm}
 \end{aligned}$$

Required thickness t_r from UG-37(a)(c)

$$\begin{aligned}
 t_r &= \frac{P \cdot K_1 \cdot D_o}{2 \cdot S \cdot E + 0,8 \cdot P} \\
 &= \frac{103,5405 \cdot 0,8737 \cdot 219,07}{2 \cdot 1.180 \cdot 1 + 0,8 \cdot 103,5405} \\
 &= 8,11 \text{ mm}
 \end{aligned}$$

Required thickness t_r per Interpretation VIII-1-07-50

$$t_r = \frac{P \cdot D_o \cdot K}{2 \cdot S \cdot E + 2 \cdot P \cdot (K - 0,1)} = \frac{103,54 \cdot 219,07 \cdot 0,961673}{2 \cdot 1.180 \cdot 0,85 + 2 \cdot 103,54 \cdot (0,961673 - 0,1)} = 9,99 \text{ mm}$$

This opening does not require reinforcement per UG-36(c)(3)(a)

UW-16(c) Weld Check

Fillet weld: $t_{\min} = \min [19\text{mm}, t_n, t] = 4,82 \text{ mm}$

$t_{c(\min)} = \min [6 \text{ mm}, 0,7 \cdot t_{\min}] = 3,38 \text{ mm}$

$t_{c(\text{actual})} = 0,7 \cdot \text{Leg} = 0,7 \cdot 8 = 5,6 \text{ mm}$

The fillet weld size is satisfactory.

Weld strength calculations are not required for this detail which conforms to Fig. UW-16.1, sketch (c-e).

UG-45 Nozzle Neck Thickness Check

Interpretation VIII-1-83-66 has been applied.

$$\begin{aligned} t_{aUG-27} &= \frac{P \cdot R_n}{S_n \cdot E - 0,6 \cdot P} + \text{Corrosion} \\ &= \frac{103,5405 \cdot 8,51}{1,180 \cdot 1 - 0,6 \cdot 103,5405} + 3 \\ &= 3,79 \text{ mm} \end{aligned}$$

$$\begin{aligned} t_a &= \max [t_{aUG-27}, t_{aUG-22}] \\ &= \max [3,79, 0] \\ &= 3,79 \text{ mm} \end{aligned}$$

$$\begin{aligned} t_{b1} &= \frac{P \cdot D_o \cdot K}{2 \cdot S \cdot E + 2 \cdot P \cdot (K - 0,1)} + \text{Corrosion} \\ &= \frac{103,54 \cdot 219,07 \cdot 0,961673}{2 \cdot 1,180 \cdot 1 + 2 \cdot 103,54 \cdot (0,961673 - 0,1)} + 3 \\ &= 11,59 \text{ mm} \end{aligned}$$

$$\begin{aligned} t_{b1} &= \max [t_{b1}, t_{bUG16}] \\ &= \max [11,59, 4,5] \\ &= 11,59 \text{ mm} \end{aligned}$$

$$\begin{aligned} t_b &= \min [t_{b3}, t_{b1}] \\ &= \min [5,51, 11,59] \\ &= 5,51 \text{ mm} \end{aligned}$$

$$\begin{aligned} t_{UG-45} &= \max [t_a, t_b] \\ &= \max [3,79, 5,51] \\ &= 5,51 \text{ mm} \end{aligned}$$

Available nozzle wall thickness new, $t_n = 0,875 \cdot 7,82 = 6,85 \text{ mm}$

The nozzle neck thickness is adequate.

Reinforcement Calculations for MAP

The vessel wall thickness governs the MAP of this nozzle.

UG-37 Area Calculation Summary (cm ²)							UG-45 Summary (mm)	
For P = 139,29 bar @ 21,11 °C							The nozzle passes UG-45	
A required	A available	A ₁	A ₂	A ₃	A ₅	A welds	t _{req}	t _{min}
This nozzle is exempt from area calculations per UG-36(c)(3)(a)							2,51	6,85

UG-41 Weld Failure Path Analysis Summary
The nozzle is exempt from weld strength calculations per UW-15(b)(2)

Calculations for internal pressure 139,29 bar @ 21,11 °C

Parallel Limit of reinforcement per UG-40

$$\begin{aligned}
 L_R &= \max [d, R_n + (t_n - C_n) + (t - C)] \\
 &= \max [11,02, 5,51 + (7,82 - 0) + (11,11 - 0)] \\
 &= 24,45 \text{ mm}
 \end{aligned}$$

Outer Normal Limit of reinforcement per UG-40

$$\begin{aligned}
 L_H &= \min [2,5 \cdot (t - C), 2,5 \cdot (t_n - C_n) + t_e] \\
 &= \min [2,5 \cdot (11,11 - 0), 2,5 \cdot (7,82 - 0) + 0] \\
 &= 19,56 \text{ mm}
 \end{aligned}$$

Nozzle required thickness per UG-27(c)(1)

$$\begin{aligned}
 t_{rn} &= \frac{P \cdot R_n}{S_n \cdot E - 0,6 \cdot P} \\
 &= \frac{139,2932 \cdot 5,51}{1.180 \cdot 1 - 0,6 \cdot 139,2932} \\
 &= 0,7 \text{ mm}
 \end{aligned}$$

Required thickness t_r from UG-37(a)(c)

$$\begin{aligned}
 t_r &= \frac{P \cdot K_1 \cdot D_o}{2 \cdot S \cdot E + 0,8 \cdot P} \\
 &= \frac{139,2932 \cdot 0,9 \cdot 219,07}{2 \cdot 1.180 \cdot 1 + 0,8 \cdot 139,2932} \\
 &= 11,11 \text{ mm}
 \end{aligned}$$

Required thickness t_r per Interpretation VIII-1-07-50

$$t_r = \frac{P \cdot D_o \cdot K}{2 \cdot S \cdot E + 2 \cdot P \cdot (K - 0,1)} = \frac{139,29 \cdot 219,07 \cdot 1}{2 \cdot 1.180 \cdot 0,85 + 2 \cdot 139,29 \cdot (1 - 0,1)} = 13,52 \text{ mm}$$

This opening does not require reinforcement per UG-36(c)(3)(a)

UG-45 Nozzle Neck Thickness Check

Interpretation VIII-1-83-66 has been applied.

$$\begin{aligned}t_{aUG-27} &= \frac{P \cdot R_n}{S_n \cdot E - 0,6 \cdot P} + \text{Corrosion} \\ &= \frac{139,2932 \cdot 5,51}{1.180 \cdot 1 - 0,6 \cdot 139,2932} + 0 \\ &= 0,7 \text{ mm}\end{aligned}$$

$$\begin{aligned}t_a &= \max [t_{aUG-27}, t_{aUG-22}] \\ &= \max [0,7, 0] \\ &= 0,7 \text{ mm}\end{aligned}$$

$$\begin{aligned}t_{b1} &= \frac{P \cdot D_o \cdot K}{2 \cdot S \cdot E + 2 \cdot P \cdot (K - 0,1)} + \text{Corrosion} \\ &= \frac{139,29 \cdot 219,07 \cdot 1}{2 \cdot 1.180 \cdot 1 + 2 \cdot 139,29 \cdot (1 - 0,1)} + 0 \\ &= 11,69 \text{ mm}\end{aligned}$$

$$\begin{aligned}t_{b1} &= \max [t_{b1}, t_{bUG16}] \\ &= \max [11,69, 1,5] \\ &= 11,69 \text{ mm}\end{aligned}$$

$$\begin{aligned}t_b &= \min [t_{b3}, t_{b1}] \\ &= \min [2,51, 11,69] \\ &= 2,51 \text{ mm}\end{aligned}$$

$$\begin{aligned}t_{UG-45} &= \max [t_a, t_b] \\ &= \max [0,7, 2,51] \\ &= 2,51 \text{ mm}\end{aligned}$$

Available nozzle wall thickness new, $t_n = 0,875 \cdot 7,82 = 6,85 \text{ mm}$

The nozzle neck thickness is adequate.

B16.9 Elbow #1 (N1)

ASME Section VIII Division 1, 2021 Edition Metric				
Component		ASME B16.9 Elbow		
Type		Long Radius 90-deg		
Material		SA-234 WPB (II-D Metric p. 16, In. 18)		
Pipe NPS and Schedule		NPS 0,75 XXS DN 20		
Attached To		Air Inlet (N1)		
Impact Tested	Normalized	Fine Grain Practice	PWHT	Maximize MDMT/ No MAWP
No	No	No	No	No
		Design Pressure (bar)	Design Temperature (°C)	Design MDMT (°C)
Internal		39	157	0
Static Liquid Head				
Condition		P_s (bar)	H_s (mm)	SG
Test horizontal		0,03	255,51	1
Dimensions				
Outer Diameter		26,67 mm		
Nominal Thickness		7,82 mm		
Minimum Thickness¹		6,85 mm		
Center-to-End, A		38 mm		
Corrosion	Inner	3 mm		
	Outer	0 mm		
Weight and Capacity				
		Weight (kg)	Capacity (liters)	
New		0,22	0,01	
Corroded		0,16	0,01	
Radiography				
Longitudinal seam		Seamless No RT		
Left Circumferential seam		Full UW-11(a) Type 1		
Right Circumferential seam		Full UW-11(a) Type 1		

¹ minimum thickness = nominal thickness times pipe tolerance factor of 0,875.

ASME B16.5-2017 Flange	
Description	NPS 0,75 Class 600 WN A105
Bolt Material	SA-193 B7 Bolt <= 64 (II-D Metric p. 410, In. 32)
Blind included	No
Rated MDMT	-48°C
Liquid static head	0 bar
MAWP rating	89,84 bar @ 157°C
MAP rating	102,1 bar @ 21,11°C
Hydrotest rating	154 bar @ 21,11°C
PWHT performed	No
Produced to Fine Grain Practice and Supplied in Heat Treated Condition	No
Impact Tested	No
Circumferential joint radiography	Full UW-11(a) Type 1
Bore diameter, B (specified by purchaser)	11,02 mm
Gasket	
Type	ASME B16.21 Nonmetallic Flat Gasket
Description	Flexitallic Compressed Fiber SF 2401 Synthetic/NBR
Factor, m	3,2
Seating Stress, y	203,89 kgf/cm ²
Thickness, T	3 mm
Inner Diameter	27 mm
Outer Diameter	67 mm
Notes	
Flange rated MDMT per UCS-66(b)(1)(b) = -48°C (Coincident ratio = 0,4008) Bolts rated MDMT per Fig UCS-66 note (c) = -48°C	

Results Summary	
Governing condition	UG-16
Minimum thickness per UG-16	1,5 mm + 3 mm = 4,5 mm
Design thickness due to internal pressure (t)	3.43 mm
Maximum allowable working pressure (MAWP)	401.45 bar
Maximum allowable pressure (MAP)	849.81 bar
Rated MDMT	-105 °C

UCS-66 Material Toughness Requirements	
$t_r = 13,34 \cdot \left(1 - \exp\left(-\frac{40,92}{1.180 \cdot 1} \right) \right) =$	0,45 mm
Stress ratio = $\frac{t_r \cdot E^*}{t_n - c} = \frac{0,45 \cdot 1}{6,85 - 3} =$	0,1182
Stress ratio $\leq 0,35$, MDMT per UCS-66(b)(3) =	-105°C
Material is exempt from impact testing at the Design MDMT of 0°C.	

Design thickness, (at 157 °C) Appendix 1-2

$$t = R_o \cdot \left(1 - \exp\left[-\frac{P}{S \cdot E} \right] \right) + \text{Corrosion} = 13,34 \cdot \left(1 - \exp\left[-\frac{39}{1.180 \cdot 1,00} \right] \right) + 3 = \text{3.43 mm}$$

Maximum allowable working pressure, (at 157 °C) Appendix 1-2

$$P = S \cdot E \cdot \ln\left(\frac{R_o}{R_o - t}\right) - P_s = 1.180 \cdot 1,00 \cdot \ln\left(\frac{13,34}{13,34 - (7,82 \cdot 0,875 - 3)}\right) - 0 = \underline{401,45} \text{ bar}$$

Maximum allowable pressure, (at 21,11 °C) Appendix 1-2

$$P = S \cdot E \cdot \ln\left(\frac{R_o}{R_o - t}\right) = 1.180 \cdot 1,00 \cdot \ln\left(\frac{13,34}{13,34 - (7,82 \cdot 0,875)}\right) = \underline{849,81} \text{ bar}$$

Cylinder #1

ASME Section VIII Division 1, 2021 Edition Metric				
Component		Cylinder		
Material		SA-106 B Smls Pipe (II-D Metric p. 16, ln. 16)		
Pipe NPS and Schedule		NPS 8 Sch 80 (XS) DN 200		
Impact Tested	Normalized	Fine Grain Practice	PWHT	Maximize MDMT/ No MAWP
No	No	No	No	No
		Design Pressure (bar)	Design Temperature (°C)	Design MDMT (°C)
Internal		39	157	0
Static Liquid Head				
Condition		P_s (bar)	H_s (mm)	SG
Test horizontal		0,03	346,84	1
Dimensions				
Outer Diameter		219,07 mm		
Length		890 mm		
Pipe Nominal Thickness		12,7 mm		
Pipe Minimum Thickness¹		11,11 mm		
Corrosion	Inner	3 mm		
	Outer	0 mm		
Weight and Capacity				
		Weight (kg)	Capacity (liters)	
New		57,11	26,22	
Corroded		44,25	27,87	
Radiography				
Longitudinal seam		Seamless No RT		
Left Circumferential seam		Spot UW-11(b) Type 1		
Right Circumferential seam		Spot UW-11(b) Type 1		

¹Pipe minimum thickness = nominal thickness times pipe tolerance factor of 0,875.

Results Summary	
Governing condition	Internal pressure
Minimum thickness per UG-16	1,5 mm + 3 mm = 4,5 mm
Design thickness due to internal pressure (t)	7,2 mm
Maximum allowable working pressure (MAWP)	76,56 bar
Maximum allowable pressure (MAP)	106,06 bar
Rated MDMT	-48 °C

UCS-66 Material Toughness Requirements	
Governing thickness, t _g =	11,11 mm
Exemption temperature from Fig UCS-66M Curve B =	-24,98°C
$t_r = \frac{40,92 \cdot 109,54}{1.180 \cdot 0,85 + 0,4 \cdot 40,92} =$	4,4 mm
$\text{Stress ratio} = \frac{t_r \cdot E^*}{t_n - c} = \frac{4,4 \cdot 0,85}{11,11 - 3} =$	0,4607
Reduction in MDMT, T _R from Fig UCS-66.1M =	36,9°C
$MDMT = \max [MDMT - T_R, -48] = \max [-24,98 - 36,9, -48] =$	-48°C
Material is exempt from impact testing at the Design MDMT of 0°C.	

Design thickness, (at 157 °C) Appendix 1-1

$$t = \frac{P \cdot R_o}{S \cdot E + 0,40 \cdot P} + \text{Corrosion} = \frac{39 \cdot 109,54}{1.180 \cdot 0,85 + 0,40 \cdot 39} + 3 = 7,2 \text{ mm}$$

Maximum allowable working pressure, (at 157 °C) Appendix 1-1

$$P = \frac{S \cdot E \cdot t}{R_o - 0,40 \cdot t} - P_s = \frac{1.180 \cdot 0,85 \cdot (12,7 \cdot 0,875 - 3)}{109,54 - 0,40 \cdot (12,7 \cdot 0,875 - 3)} - 0 = 76,56 \text{ bar}$$

Maximum allowable pressure, (at 21,11 °C) Appendix 1-1

$$P = \frac{S \cdot E \cdot t}{R_o - 0,40 \cdot t} = \frac{1.180 \cdot 0,85 \cdot (12,7 \cdot 0,875)}{109,54 - 0,40 \cdot (12,7 \cdot 0,875)} = 106,06 \text{ bar}$$

Temperature Transmitter Connection (N3)

ASME Section VIII Division 1, 2021 Edition Metric

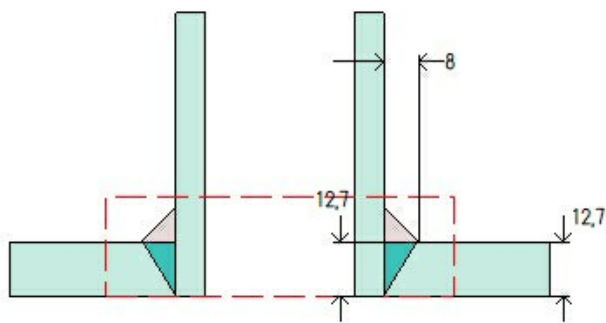

Note: round inside edges per UG-76(c)

Location and Orientation

Located on	Cylinder #1
Orientation	0°
Nozzle center line offset to datum line	575 mm
End of nozzle to shell center	250 mm
Passes through a Category A joint	No

Nozzle

Description	NPS 1,5 Sch 160 DN 40
Access opening	No
Material specification	SA-106 B Smls Pipe (II-D Metric p. 16, In. 16)
Inside diameter, new	33,99 mm
Pipe nominal wall thickness	7,14 mm
Pipe minimum wall thickness ¹	6,25 mm
Corrosion allowance	3 mm
Projection available outside vessel, L _{pr}	64,27 mm
Projection available outside vessel to flange face, L _f	140,47 mm
Local vessel minimum thickness	11,11 mm
Liquid static head included	0 bar

Welds

Inner fillet, Leg ₄₁	8 mm
Nozzle to vessel groove weld	12,7 mm

Radiography

Longitudinal seam	Seamless No RT
Circumferential seam	Full UW-11(a) Type 1

¹Pipe minimum thickness = nominal thickness times pipe tolerance factor of 0,875.

ASME B16.5-2017 Flange	
Description	NPS 1,5 Class 600 WN A105
Bolt Material	SA-193 B7 Bolt <= 64 (II-D Metric p. 410, In. 32)
Blind included	No
Rated MDMT	-48°C
Liquid static head	0 bar
MAWP rating	89,84 bar @ 157°C
MAP rating	102,1 bar @ 21,11°C
Hydrotest rating	154 bar @ 21,11°C
PWHT performed	No
Produced to Fine Grain Practice and Supplied in Heat Treated Condition	No
Impact Tested	No
Circumferential joint radiography	Full UW-11(a) Type 1
Bore diameter, B (specified by purchaser)	40,89 mm
Gasket	
Type	ASME B16.20 Spiral-Wound
Description	Garlock FLEXSEAL RW 316L SS / Flexible Graphite
Factor, m	3
Seating Stress, y	703,07 kgf/cm ²
Thickness, T	3 mm
Inner Diameter	54,1 mm
Outer Diameter	69,9 mm
Notes	
Flange rated MDMT per UCS-66(b)(1)(b) = -48°C (Coincident ratio = 0,4008) Bolts rated MDMT per Fig UCS-66 note (c) = -48°C	

UCS-66 Material Toughness Requirements Nozzle	
$t_r = \frac{40,92 \cdot 19,99}{1,180 \cdot 1 - 0,6 \cdot 40,92} =$	0,71 mm
Stress ratio = $\frac{t_r \cdot E^*}{t_n - c} = \frac{0,71 \cdot 1}{6,25 - 3} =$	0,2182
Stress ratio ≤ 0,35, MDMT per UCS-66(b)(3) =	-105°C
Material is exempt from impact testing at the Design MDMT of 0°C.	

Reinforcement Calculations for Internal Pressure

UG-37 Area Calculation Summary (cm ²)							UG-45 Summary (mm)	
For P = 39 bar @ 157 °C							The nozzle passes UG-45	
A required	A available	A ₁	A ₂	A ₃	A ₅	A welds	t _{req}	t _{min}
This nozzle is exempt from area calculations per UG-36(c)(3)(a)							6,22	6,25

UG-41 Weld Failure Path Analysis Summary
The nozzle is exempt from weld strength calculations per UW-15(b)(2)

UW-16 Weld Sizing Summary			
Weld description	Required weld throat size (mm)	Actual weld throat size (mm)	Status
Nozzle to shell fillet (Leg ₄₁)	2,9	5,6	weld size is adequate

Calculations for internal pressure 39 bar @ 157 °C

Parallel Limit of reinforcement per UG-40

$$\begin{aligned}
 L_R &= \max [d, R_n + (t_n - C_n) + (t - C)] \\
 &= \max [39,99, 19,99 + (7,14 - 3) + (11,11 - 3)] \\
 &= 39,99 \text{ mm}
 \end{aligned}$$

Outer Normal Limit of reinforcement per UG-40

$$\begin{aligned}
 L_H &= \min [2,5 \cdot (t - C), 2,5 \cdot (t_n - C_n) + t_e] \\
 &= \min [2,5 \cdot (11,11 - 3), 2,5 \cdot (7,14 - 3) + 0] \\
 &= 10,34 \text{ mm}
 \end{aligned}$$

Nozzle required thickness per UG-27(c)(1)

$$\begin{aligned}
 t_{rn} &= \frac{P \cdot R_n}{S_n \cdot E - 0,6 \cdot P} \\
 &= \frac{39,0001 \cdot 19,99}{1,180 \cdot 1 - 0,6 \cdot 39,0001} \\
 &= 0,67 \text{ mm}
 \end{aligned}$$

Required thickness t_r from UG-37(a)

$$\begin{aligned}
 t_r &= \frac{P \cdot R_o}{S \cdot E + 0,4 \cdot P} \\
 &= \frac{39,0001 \cdot 109,54}{1,180 \cdot 1 + 0,4 \cdot 39,0001} \\
 &= 3,57 \text{ mm}
 \end{aligned}$$

Required thickness t_r per Interpretation VIII-1-07-50

$$\begin{aligned}
t_r &= \frac{P \cdot R_o}{S \cdot E + 0,4 \cdot P} \\
&= \frac{39,0001 \cdot 109,54}{1.180 \cdot 0,85 + 0,4 \cdot 39,0001} \\
&= 4,19 \text{ mm}
\end{aligned}$$

This opening does not require reinforcement per UG-36(c)(3)(a)

UW-16(c) Weld Check

Fillet weld: $t_{\min} = \min [19\text{mm}, t_n, t] = 4,14 \text{ mm}$

$$t_{c(\min)} = \min [6 \text{ mm}, 0,7 \cdot t_{\min}] = 2,9 \text{ mm}$$

$$t_{c(\text{actual})} = 0,7 \cdot \text{Leg} = 0,7 \cdot 8 = 5,6 \text{ mm}$$

The fillet weld size is satisfactory.

Weld strength calculations are not required for this detail which conforms to Fig. UW-16.1, sketch (c-e).

UG-45 Nozzle Neck Thickness Check

$$\begin{aligned}
t_{aUG-27} &= \frac{P \cdot R_n}{S_n \cdot E - 0,6 \cdot P} + \text{Corrosion} \\
&= \frac{39,0001 \cdot 19,99}{1.180 \cdot 1 - 0,6 \cdot 39,0001} + 3 \\
&= 3,67 \text{ mm}
\end{aligned}$$

$$\begin{aligned}
t_a &= \max [t_{aUG-27}, t_{aUG-22}] \\
&= \max [3,67, 0] \\
&= 3,67 \text{ mm}
\end{aligned}$$

$$\begin{aligned}
t_{b1} &= \frac{P \cdot R_o}{S \cdot E + 0,4 \cdot P} + \text{Corrosion} \\
&= \frac{39,0001 \cdot 109,54}{1.180 \cdot 1 + 0,4 \cdot 39,0001} + 3 \\
&= 6,57 \text{ mm}
\end{aligned}$$

$$\begin{aligned}
t_{b1} &= \max [t_{b1}, t_{bUG16}] \\
&= \max [6,57, 4,5] \\
&= 6,57 \text{ mm}
\end{aligned}$$

$$\begin{aligned}
t_b &= \min [t_{b3}, t_{b1}] \\
&= \min [6,22, 6,57] \\
&= 6,22 \text{ mm}
\end{aligned}$$

$$\begin{aligned}
t_{UG-45} &= \max [t_a, t_b] \\
&= \max [3,67, 6,22] \\
&= 6,22 \text{ mm}
\end{aligned}$$

Available nozzle wall thickness new, $t_n = 0,875 \cdot 7,14 = 6,25$ mm

The nozzle neck thickness is adequate.

Reinforcement Calculations for MAWP

The attached ASME B16.5 flange limits the nozzle MAWP.

UG-37 Area Calculation Summary (cm ²)						UG-45 Summary (mm)		
For P = 89,84 bar @ 157 °C						The nozzle passes UG-45		
A required	A available	A ₁	A ₂	A ₃	A ₅	A welds	t _{req}	t _{min}
This nozzle is exempt from area calculations per UG-36(c)(3)(a)						6,22	6,25	

UG-41 Weld Failure Path Analysis Summary
The nozzle is exempt from weld strength calculations per UW-15(b)(2)

UW-16 Weld Sizing Summary			
Weld description	Required weld throat size (mm)	Actual weld throat size (mm)	Status
Nozzle to shell fillet (Leg ₄₁)	2,9	5,6	weld size is adequate

Calculations for internal pressure 89,84 bar @ 157 °C

Parallel Limit of reinforcement per UG-40

$$\begin{aligned}
 L_R &= \max [d, R_n + (t_n - C_n) + (t - C)] \\
 &= \max [39,99, 19,99 + (7,14 - 3) + (11,11 - 3)] \\
 &= 39,99 \text{ mm}
 \end{aligned}$$

Outer Normal Limit of reinforcement per UG-40

$$\begin{aligned}
 L_H &= \min [2,5 \cdot (t - C), 2,5 \cdot (t_n - C_n) + t_e] \\
 &= \min [2,5 \cdot (11,11 - 3), 2,5 \cdot (7,14 - 3) + 0] \\
 &= 10,34 \text{ mm}
 \end{aligned}$$

Nozzle required thickness per UG-27(c)(1)

$$\begin{aligned}
 t_{rn} &= \frac{P \cdot R_n}{S_n \cdot E - 0,6 \cdot P} \\
 &= \frac{89,836 \cdot 19,99}{1,180 \cdot 1 - 0,6 \cdot 89,836} \\
 &= 1,6 \text{ mm}
 \end{aligned}$$

Required thickness t_r from UG-37(a)

$$\begin{aligned}
 t_r &= \frac{P \cdot R_o}{S \cdot E + 0,4 \cdot P} \\
 &= \frac{89,836 \cdot 109,54}{1,180 \cdot 1 + 0,4 \cdot 89,836} \\
 &= 8,09 \text{ mm}
 \end{aligned}$$

Required thickness t_r per Interpretation VIII-1-07-50

$$\begin{aligned}
t_r &= \frac{P \cdot R_o}{S \cdot E + 0,4 \cdot P} \\
&= \frac{89,836 \cdot 109,54}{1.180 \cdot 0,85 + 0,4 \cdot 89,836} \\
&= 9,47 \text{ mm}
\end{aligned}$$

This opening does not require reinforcement per UG-36(c)(3)(a)

UW-16(c) Weld Check

Fillet weld: $t_{\min} = \min [19\text{mm}, t_n, t] = 4,14 \text{ mm}$

$t_{c(\min)} = \min [6 \text{ mm}, 0,7 \cdot t_{\min}] = 2,9 \text{ mm}$

$t_{c(\text{actual})} = 0,7 \cdot \text{Leg} = 0,7 \cdot 8 = 5,6 \text{ mm}$

The fillet weld size is satisfactory.

Weld strength calculations are not required for this detail which conforms to Fig. UW-16.1, sketch (c-e).

UG-45 Nozzle Neck Thickness Check

$$\begin{aligned}
t_{aUG-27} &= \frac{P \cdot R_n}{S_n \cdot E - 0,6 \cdot P} + \text{Corrosion} \\
&= \frac{89,836 \cdot 19,99}{1.180 \cdot 1 - 0,6 \cdot 89,836} + 3 \\
&= 4,6 \text{ mm}
\end{aligned}$$

$$\begin{aligned}
t_a &= \max [t_{aUG-27}, t_{aUG-22}] \\
&= \max [4,6, 0] \\
&= 4,6 \text{ mm}
\end{aligned}$$

$$\begin{aligned}
t_{b1} &= \frac{P \cdot R_o}{S \cdot E + 0,4 \cdot P} + \text{Corrosion} \\
&= \frac{89,836 \cdot 109,54}{1.180 \cdot 1 + 0,4 \cdot 89,836} + 3 \\
&= 11,09 \text{ mm}
\end{aligned}$$

$$\begin{aligned}
t_{b1} &= \max [t_{b1}, t_{bUG16}] \\
&= \max [11,09, 4,5] \\
&= 11,09 \text{ mm}
\end{aligned}$$

$$\begin{aligned}
t_b &= \min [t_{b3}, t_{b1}] \\
&= \min [6,22, 11,09] \\
&= 6,22 \text{ mm}
\end{aligned}$$

$$\begin{aligned}
t_{UG-45} &= \max [t_a, t_b] \\
&= \max [4,6, 6,22] \\
&= 6,22 \text{ mm}
\end{aligned}$$

Available nozzle wall thickness new, $t_n = 0,875 \cdot 7,14 = 6,25$ mm

The nozzle neck thickness is adequate.

Reinforcement Calculations for MAP

The attached ASME B16.5 flange limits the nozzle MAP.

UG-37 Area Calculation Summary (cm ²)							UG-45 Summary (mm)	
For P = 102,1 bar @ 21,11 °C							The nozzle passes UG-45	
A required	A available	A ₁	A ₂	A ₃	A ₅	A welds	t _{req}	t _{min}
This nozzle is exempt from area calculations per UG-36(c)(3)(a)							3,22	6,25

UG-41 Weld Failure Path Analysis Summary
The nozzle is exempt from weld strength calculations per UW-15(b)(2)

Calculations for internal pressure 102,1 bar @ 21,11 °C

Parallel Limit of reinforcement per UG-40

$$\begin{aligned}
 L_R &= \max [d, R_n + (t_n - C_n) + (t - C)] \\
 &= \max [33,99, 16,99 + (7,14 - 0) + (11,11 - 0)] \\
 &= 35,24 \text{ mm}
 \end{aligned}$$

Outer Normal Limit of reinforcement per UG-40

$$\begin{aligned}
 L_H &= \min [2,5 \cdot (t - C), 2,5 \cdot (t_n - C_n) + t_e] \\
 &= \min [2,5 \cdot (11,11 - 0), 2,5 \cdot (7,14 - 0) + 0] \\
 &= 17,84 \text{ mm}
 \end{aligned}$$

Nozzle required thickness per UG-27(c)(1)

$$\begin{aligned}
 t_{rn} &= \frac{P \cdot R_n}{S_n \cdot E - 0,6 \cdot P} \\
 &= \frac{102,1 \cdot 16,99}{1.180 \cdot 1 - 0,6 \cdot 102,1} \\
 &= 1,55 \text{ mm}
 \end{aligned}$$

Required thickness t_r from UG-37(a)

$$\begin{aligned}
 t_r &= \frac{P \cdot R_o}{S \cdot E + 0,4 \cdot P} \\
 &= \frac{102,1 \cdot 109,54}{1.180 \cdot 1 + 0,4 \cdot 102,1} \\
 &= 9,16 \text{ mm}
 \end{aligned}$$

Required thickness t_r per Interpretation VIII-1-07-50

$$\begin{aligned}
 t_r &= \frac{P \cdot R_o}{S \cdot E + 0,4 \cdot P} \\
 &= \frac{102,1 \cdot 109,54}{1.180 \cdot 0,85 + 0,4 \cdot 102,1} \\
 &= 10,71 \text{ mm}
 \end{aligned}$$

This opening does not require reinforcement per UG-36(c)(3)(a)

UG-45 Nozzle Neck Thickness Check

$$\begin{aligned}t_{aUG-27} &= \frac{P \cdot R_n}{S_n \cdot E - 0,6 \cdot P} + \text{Corrosion} \\ &= \frac{102,1 \cdot 16,99}{1.180 \cdot 1 - 0,6 \cdot 102,1} + 0 \\ &= 1,55 \text{ mm}\end{aligned}$$

$$\begin{aligned}t_a &= \max [t_{aUG-27}, t_{aUG-22}] \\ &= \max [1,55, 0] \\ &= 1,55 \text{ mm}\end{aligned}$$

$$\begin{aligned}t_{b1} &= \frac{P \cdot R_o}{S \cdot E + 0,4 \cdot P} + \text{Corrosion} \\ &= \frac{102,1 \cdot 109,54}{1.180 \cdot 1 + 0,4 \cdot 102,1} + 0 \\ &= 9,16 \text{ mm}\end{aligned}$$

$$\begin{aligned}t_{b1} &= \max [t_{b1}, t_{bUG16}] \\ &= \max [9,16, 1,5] \\ &= 9,16 \text{ mm}\end{aligned}$$

$$\begin{aligned}t_b &= \min [t_{b3}, t_{b1}] \\ &= \min [3,22, 9,16] \\ &= 3,22 \text{ mm}\end{aligned}$$

$$\begin{aligned}t_{UG-45} &= \max [t_a, t_b] \\ &= \max [1,55, 3,22] \\ &= \underline{3,22} \text{ mm}\end{aligned}$$

Available nozzle wall thickness new, $t_n = 0,875 \cdot 7,14 = 6,25 \text{ mm}$

The nozzle neck thickness is adequate.

Drain (N4)

ASME Section VIII Division 1, 2021 Edition Metric

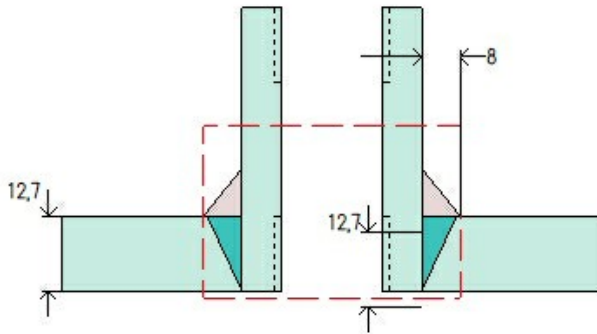

Note: round inside edges per UG-76(c)

Location and Orientation

Located on	Cylinder #1
Orientation	180°
Nozzle center line offset to datum line	470 mm
End of nozzle to shell center	142,69 mm
Passes through a Category A joint	No
Nozzle	
Description	NPS 0,5 Class 6000 DN 15 - Threaded Full Coupling
Access opening	No
Material specification	SA-105 (II-D Metric p. 20, In. 31)
Inside diameter, new	21,34 mm
Nominal wall thickness	8,38 mm
Corrosion allowance	3 mm
Projection available outside vessel, L _{pr}	33,16 mm
Local vessel minimum thickness	11,11 mm
Liquid static head included	0 bar
Welds	
Inner fillet, Leg ₄₁	8 mm
Nozzle to vessel groove weld	12,7 mm
Radiography	
Longitudinal seam	Seamless No RT

UCS-66 Material Toughness Requirements Nozzle

$t_r = \frac{40,92 \cdot 13,67}{1,380 \cdot 1 - 0,6 \cdot 40,92} =$	0,41 mm
Stress ratio = $\frac{t_r \cdot E^*}{t_n - c} = \frac{0,41 \cdot 1}{8,38 - 3} =$	0,0767
Stress ratio $\leq 0,35$, MDMT per UCS-66(b)(3) =	-105°C
Material is exempt from impact testing at the Design MDMT of 0°C.	

Reinforcement Calculations for Internal Pressure

UG-37 Area Calculation Summary (cm ²)							UG-44 Summary (mm)	
For P = 39 bar @ 157 °C							The nozzle passes UG-44	
A required	A available	A ₁	A ₂	A ₃	A ₅	A welds	t _{req}	t _{min}
This nozzle is exempt from area calculations per UG-36(c)(3)(a)							4,5	8,38

UG-41 Weld Failure Path Analysis Summary
The nozzle is exempt from weld strength calculations per UW-15(b)(2)

UW-16 Weld Sizing Summary			
Weld description	Required weld throat size (mm)	Actual weld throat size (mm)	Status
Nozzle to shell fillet (Leg ₄₁)	2,5	5,6	weld size is adequate

Calculations for internal pressure 39 bar @ 157 °C

Parallel Limit of reinforcement per UG-40

$$\begin{aligned}
 L_R &= \max [d, R_n + (t_n - C_n) + (t - C)] \\
 &= \max [27,34, 13,67 + (8,38 - 3) + (11,11 - 3)] \\
 &= 27,34 \text{ mm}
 \end{aligned}$$

Outer Normal Limit of reinforcement per UG-40

$$\begin{aligned}
 L_H &= \min [2,5 \cdot (t - C), 2,5 \cdot (t_n - C_n) + t_e] \\
 &= \min [2,5 \cdot (11,11 - 3), 2,5 \cdot (8,38 - 3) + 0] \\
 &= 13,46 \text{ mm}
 \end{aligned}$$

Nozzle required thickness per UG-27(c)(1)

$$\begin{aligned}
 t_{rn} &= \frac{P \cdot R_n}{S_n \cdot E - 0,6 \cdot P} \\
 &= \frac{39,0001 \cdot 13,67}{1,380 \cdot 1 - 0,6 \cdot 39,0001} \\
 &= 0,39 \text{ mm}
 \end{aligned}$$

Required thickness t_r from UG-37(a)

$$\begin{aligned}
 t_r &= \frac{P \cdot R_o}{S \cdot E + 0,4 \cdot P} \\
 &= \frac{39,0001 \cdot 109,54}{1,180 \cdot 1 + 0,4 \cdot 39,0001} \\
 &= 3,57 \text{ mm}
 \end{aligned}$$

Required thickness t_r per Interpretation VIII-1-07-50

$$\begin{aligned}
t_r &= \frac{P \cdot R_o}{S \cdot E + 0,4 \cdot P} \\
&= \frac{39,0001 \cdot 109,54}{1.180 \cdot 0,85 + 0,4 \cdot 39,0001} \\
&= 4,19 \text{ mm}
\end{aligned}$$

This opening does not require reinforcement per UG-36(c)(3)(a)

UW-16(f)(2)(b) Weld Check

Fillet weld: $t_{\min} = \min [19mm, t_n, t] = 5,38 \text{ mm}$

$$t_{c(\min)} = \min [2,5 \text{ mm}, 0,7 \cdot t_{\min}] = 2,5 \text{ mm}$$

$$t_{c(actual)} = 0,7 \cdot \text{Leg} = 0,7 \cdot 8 = 5,6 \text{ mm}$$

The fillet weld size is satisfactory.

Weld strength calculations are not required for this detail which conforms to Fig. UW-16.1, sketch (c-e).

UG-44 Thickness Check - ASME B16.11 Coupling

$$\begin{aligned}
t_{aApp 1-1} &= \frac{P \cdot R_o}{S_n \cdot E + 0,4 \cdot P} + \text{Corrosion} \\
&= \frac{39,0001 \cdot 19,05}{1.380 \cdot 1 + 0,4 \cdot 39,0001} + 3 \\
&= 3,53 \text{ mm}
\end{aligned}$$

$$\begin{aligned}
t_{aUG-44} &= \max [t_{aApp 1-1}, t_{bUG16}] \\
&= \max [3,53, 4,5] \\
&= 4,5 \text{ mm}
\end{aligned}$$

Available nozzle wall thickness new, $t_n = 8,38 \text{ mm}$

The nozzle neck thickness is adequate.

Reinforcement Calculations for MAWP

The vessel wall thickness governs the MAWP of this nozzle.

UG-37 Area Calculation Summary (cm ²)						UG-44 Summary (mm)		
For P = 90,07 bar @ 157 °C						The nozzle passes UG-44		
A required	A available	A ₁	A ₂	A ₃	A ₅	A welds	t _{req}	t _{min}
This nozzle is exempt from area calculations per UG-36(c)(3)(a)						4,5	8,38	

UG-41 Weld Failure Path Analysis Summary
The nozzle is exempt from weld strength calculations per UW-15(b)(2)

UW-16 Weld Sizing Summary			
Weld description	Required weld throat size (mm)	Actual weld throat size (mm)	Status
Nozzle to shell fillet (Leg ₄₁)	2,5	5,6	weld size is adequate

Calculations for internal pressure 90,07 bar @ 157 °C

Parallel Limit of reinforcement per UG-40

$$\begin{aligned}
 L_R &= \max [d, R_n + (t_n - C_n) + (t - C)] \\
 &= \max [27,34, 13,67 + (8,38 - 3) + (11,11 - 3)] \\
 &= 27,34 \text{ mm}
 \end{aligned}$$

Outer Normal Limit of reinforcement per UG-40

$$\begin{aligned}
 L_H &= \min [2,5 \cdot (t - C), 2,5 \cdot (t_n - C_n) + t_e] \\
 &= \min [2,5 \cdot (11,11 - 3), 2,5 \cdot (8,38 - 3) + 0] \\
 &= 13,46 \text{ mm}
 \end{aligned}$$

Nozzle required thickness per UG-27(c)(1)

$$\begin{aligned}
 t_{rn} &= \frac{P \cdot R_n}{S_n \cdot E - 0,6 \cdot P} \\
 &= \frac{90,0666 \cdot 13,67}{1,380 \cdot 1 - 0,6 \cdot 90,0666} \\
 &= 0,93 \text{ mm}
 \end{aligned}$$

Required thickness t_r from UG-37(a)

$$\begin{aligned}
 t_r &= \frac{P \cdot R_o}{S \cdot E + 0,4 \cdot P} \\
 &= \frac{90,0666 \cdot 109,54}{1,180 \cdot 1 + 0,4 \cdot 90,0666} \\
 &= 8,11 \text{ mm}
 \end{aligned}$$

Required thickness t_r per Interpretation VIII-1-07-50

$$\begin{aligned}
t_r &= \frac{P \cdot R_o}{S \cdot E + 0,4 \cdot P} \\
&= \frac{90,0666 \cdot 109,54}{1.180 \cdot 0,85 + 0,4 \cdot 90,0666} \\
&= 9,49 \text{ mm}
\end{aligned}$$

This opening does not require reinforcement per UG-36(c)(3)(a)

UW-16(f)(2)(b) Weld Check

Fillet weld: $t_{\min} = \min [19\text{mm}, t_n, t] = 5,38 \text{ mm}$

$t_{c(\min)} = \min [2,5 \text{ mm}, 0,7 \cdot t_{\min}] = 2,5 \text{ mm}$

$t_{c(\text{actual})} = 0,7 \cdot \text{Leg} = 0,7 \cdot 8 = 5,6 \text{ mm}$

The fillet weld size is satisfactory.

Weld strength calculations are not required for this detail which conforms to Fig. UW-16.1, sketch (c-e).

UG-44 Thickness Check - ASME B16.11 Coupling

$$\begin{aligned}
t_{a\text{App } 1-1} &= \frac{P \cdot R_o}{S_n \cdot E + 0,4 \cdot P} + \text{Corrosion} \\
&= \frac{90,0666 \cdot 19,05}{1.380 \cdot 1 + 0,4 \cdot 90,0666} + 3 \\
&= 4,21 \text{ mm}
\end{aligned}$$

$$\begin{aligned}
t_{a\text{UG-44}} &= \max [t_{a\text{App } 1-1}, t_{\text{UG16}}] \\
&= \max [4,21, 4,5] \\
&= 4,5 \text{ mm}
\end{aligned}$$

Available nozzle wall thickness new, $t_n = 8,38 \text{ mm}$

The nozzle neck thickness is adequate.

Reinforcement Calculations for MAP

The vessel wall thickness governs the MAP of this nozzle.

UG-37 Area Calculation Summary (cm ²)							UG-44 Summary (mm)	
For P = 124,78 bar @ 21,11 °C							The nozzle passes UG-44	
A required	A available	A ₁	A ₂	A ₃	A ₅	A welds	t _{req}	t _{min}
This nozzle is exempt from area calculations per UG-36(c)(3)(a)							1,66	8,38

UG-41 Weld Failure Path Analysis Summary
The nozzle is exempt from weld strength calculations per UW-15(b)(2)

Calculations for internal pressure 124,78 bar @ 21,11 °C

Parallel Limit of reinforcement per UG-40

$$\begin{aligned}
 L_R &= \max [d, R_n + (t_n - C_n) + (t - C)] \\
 &= \max [21,34, 10,67 + (8,38 - 0) + (11,11 - 0)] \\
 &= 30,16 \text{ mm}
 \end{aligned}$$

Outer Normal Limit of reinforcement per UG-40

$$\begin{aligned}
 L_H &= \min [2,5 \cdot (t - C), 2,5 \cdot (t_n - C_n) + t_e] \\
 &= \min [2,5 \cdot (11,11 - 0), 2,5 \cdot (8,38 - 0) + 0] \\
 &= 20,96 \text{ mm}
 \end{aligned}$$

Nozzle required thickness per UG-27(c)(1)

$$\begin{aligned}
 t_{rn} &= \frac{P \cdot R_n}{S_n \cdot E - 0,6 \cdot P} \\
 &= \frac{124,7779 \cdot 10,67}{1,380 \cdot 1 - 0,6 \cdot 124,7779} \\
 &= 1,02 \text{ mm}
 \end{aligned}$$

Required thickness t_r from UG-37(a)

$$\begin{aligned}
 t_r &= \frac{P \cdot R_o}{S \cdot E + 0,4 \cdot P} \\
 &= \frac{124,7779 \cdot 109,54}{1,180 \cdot 1 + 0,4 \cdot 124,7779} \\
 &= 11,11 \text{ mm}
 \end{aligned}$$

Required thickness t_r per Interpretation VIII-1-07-50

$$\begin{aligned}
 t_r &= \frac{P \cdot R_o}{S \cdot E + 0,4 \cdot P} \\
 &= \frac{124,7779 \cdot 109,54}{1,180 \cdot 0,85 + 0,4 \cdot 124,7779} \\
 &= 12,98 \text{ mm}
 \end{aligned}$$

This opening does not require reinforcement per UG-36(c)(3)(a)

UG-44 Thickness Check - ASME B16.11 Coupling

$$\begin{aligned}t_{aApp\ 1-1} &= \frac{P \cdot R_o}{S_n \cdot E + 0,4 \cdot P} + \text{Corrosion} \\&= \frac{124,7779 \cdot 19,05}{1,380 \cdot 1 + 0,4 \cdot 124,7779} + 0 \\&= 1,66 \text{ mm}\end{aligned}$$

$$\begin{aligned}t_{aUG-44} &= \max [t_{aApp\ 1-1}, t_{UG16}] \\&= \max [1,66, 1,5] \\&= \underline{1,66} \text{ mm}\end{aligned}$$

Available nozzle wall thickness new, $t_n = 8,38 \text{ mm}$

The nozzle neck thickness is adequate.

Straight Flange on B16.9 Pipe Cap - Right Side

ASME Section VIII Division 1, 2021 Edition Metric				
Component		Cylinder		
Material		SA-234 WPB (II-D Metric p. 16, ln. 18)		
Impact Tested	Normalized	Fine Grain Practice	PWHT	Maximize MDMT/ No MAWP
No	No	No	No	No
		Design Pressure (bar)	Design Temperature (°C)	Design MDMT (°C)
Internal		39	157	0
Static Liquid Head				
Condition		P_s (bar)	H_s (mm)	SG
Test horizontal		0,03	346,84	1
Dimensions				
Outer Diameter		219,07 mm		
Length		42,47 mm		
Nominal Thickness		12,7 mm		
Corrosion	Inner	3 mm		
	Outer	0 mm		
Weight and Capacity				
		Weight (kg)		Capacity (liters)
New		2,74		1,25
Corroded		2,12		1,33
Radiography				
Longitudinal seam		Seamless No RT		
Left Circumferential seam		Spot UW-11(b) Type 1		

Results Summary	
Governing condition	Internal pressure
Minimum thickness per UG-16	1,5 mm + 3 mm = 4,5 mm
Design thickness due to internal pressure (t)	7,2 mm
Maximum allowable working pressure (MAWP)	92,09 bar
Maximum allowable pressure (MAP)	121,95 bar
Rated MDMT	-48 °C

UCS-66 Material Toughness Requirements	
Governing thickness, t _g =	11,11 mm
Exemption temperature from Fig UCS-66M Curve B =	-24,98°C
$t_r = \frac{40,92 \cdot 109,54}{1,180 \cdot 0,85 + 0,4 \cdot 40,92} =$	4,4 mm
$\text{Stress ratio} = \frac{t_r \cdot E^*}{t_n - c} = \frac{4,4 \cdot 0,85}{12,7 - 3} =$	0,3853
Reduction in MDMT, T _R from Fig UCS-66.1M =	57,6°C
$MDMT = \max [MDMT - T_R, -48] = \max [-24,98 - 57,6, -48] =$	-48°C
Material is exempt from impact testing at the Design MDMT of 0°C.	

Design thickness, (at 157 °C) Appendix 1-1

$$t = \frac{P \cdot R_o}{S \cdot E + 0,40 \cdot P} + \text{Corrosion} = \frac{39 \cdot 109,54}{1.180 \cdot 0,85 + 0,40 \cdot 39} + 3 = \underline{7,2} \text{ mm}$$

Maximum allowable working pressure, (at 157 °C) Appendix 1-1

$$P = \frac{S \cdot E \cdot t}{R_o - 0,40 \cdot t} - P_s = \frac{1.180 \cdot 0,85 \cdot 9,7}{109,54 - 0,40 \cdot 9,7} - 0 = \underline{92,09} \text{ bar}$$

Maximum allowable pressure, (at 21,11 °C) Appendix 1-1

$$P = \frac{S \cdot E \cdot t}{R_o - 0,40 \cdot t} = \frac{1.180 \cdot 0,85 \cdot 12,7}{109,54 - 0,40 \cdot 12,7} = \underline{121,95} \text{ bar}$$

ASME Section VIII Division 1 UG-80(a) Out-of-Roundness
$(D_{\max} - D_{\min})$ shall not exceed 1% of D
When the cross section passes through an opening or within 1 I.D. of the opening, $(D_{\max} - D_{\min})$ shall not exceed 1% of $D + 2\%$ of the inside diameter of the opening

B16.9 Pipe Cap - Right Side

ASME Section VIII Division 1, 2021 Edition Metric				
Component		ASME B16.9 Pipe Cap (modified)		
Material		SA-234 WPB (II-D Metric p. 16, In. 18)		
Attached To		Cylinder #1		
Impact Tested	Normalized	Fine Grain Practice	PWHT	Maximize MDMT/ No MAWP
No	No	No	No	No
		Design Pressure (bar)	Design Temperature (°C)	Design MDMT (°C)
Internal		39	157	0
Static Liquid Head				
Condition		P_s (bar)	H_s (mm)	SG
Test horizontal		0,03	346,84	1
Dimensions				
NPS and Schedule		NPS 8 Sch 80 (XS) DN 200		
Outer Diameter		219,07 mm		
Overall Length E		102 mm		
Nominal Thickness		12,7 mm		
Minimum Thickness¹		11,11 mm		
Corrosion	Inner	3 mm		
	Outer	0 mm		
Length L_{sf}		42,47 mm		
Nominal Thickness t_{sf}		12,7 mm		
Weight and Capacity				
		Weight (kg)²	Capacity (liters)²	
New		7,72	2,2	
Corroded		6,06	2,4	
Radiography				
Category A joints		Seamless No RT		
Head to shell seam		Spot UW-11(b) Type 1		

¹ minimum thickness = nominal thickness times pipe tolerance factor of 0,875.

² includes straight flange

Results Summary	
Governing condition	internal pressure
Minimum thickness per UG-16	1,5 mm + 3 mm = 4,5 mm
Design thickness due to internal pressure (t)	<u>6,96</u> mm
Governing straight flange design thickness	7,2 mm
Maximum allowable working pressure (MAWP)	<u>82,74</u> bar
Maximum allowable pressure (MAP)	<u>111,98</u> bar
<u>Straight Flange</u> governs MDMT	-48°C

Factor K		
	$K = \left(\frac{1}{6}\right) \cdot \left[2 + \left(\frac{D}{2 \cdot h}\right)^2\right]$	
Corroded	$K = \left(\frac{1}{6}\right) \cdot \left[2 + \left(\frac{199,67}{2 \cdot 51,42}\right)^2\right]$	0,9617
New	$K = \left(\frac{1}{6}\right) \cdot \left[2 + \left(\frac{193,67}{2 \cdot 48,42}\right)^2\right]$	1

Design thickness for internal pressure, (Corroded at 157 °C) Appendix 1-4(c)

$$t = \frac{P \cdot D_o \cdot K}{2 \cdot S \cdot E + 2 \cdot P \cdot (K - 0,1)} + \text{Corrosion} = \frac{39 \cdot 219,07 \cdot 0,961673}{2 \cdot 1.180 \cdot 0,85 + 2 \cdot 39 \cdot (0,961673 - 0,1)} + 3 = 6.96 \text{ mm}$$

Maximum allowable working pressure, (Corroded at 157 °C) Appendix 1-4(c)

$$P = \frac{2 \cdot S \cdot E \cdot t}{K \cdot D_o - 2 \cdot t \cdot (K - 0,1)} - P_s = \frac{2 \cdot 1.180 \cdot 0,85 \cdot (0,875 \cdot 12,7 - 3)}{0,961673 \cdot 219,07 - 2 \cdot (0,875 \cdot 12,7 - 3) \cdot (0,961673 - 0,1)} - 0 = 82.74 \text{ bar}$$

Maximum allowable pressure, (New at 21,11 °C) Appendix 1-4(c)

$$P = \frac{2 \cdot S \cdot E \cdot t}{K \cdot D_o - 2 \cdot t \cdot (K - 0,1)} - P_s = \frac{2 \cdot 1.180 \cdot 0,85 \cdot 0,875 \cdot 12,7}{1 \cdot 219,07 - 2 \cdot 0,875 \cdot 12,7 \cdot (1 - 0,1)} - 0 = 111.98 \text{ bar}$$

ASME Section VIII Division 1 UG-81(a) Out-of-Roundness
Inside surface shall not deviate outside the shape by more than 1,25 % of D
Inside surface shall not deviate inside the shape by more than 0,625 % of D

Air Outlet (N2)

ASME Section VIII Division 1, 2021 Edition Metric

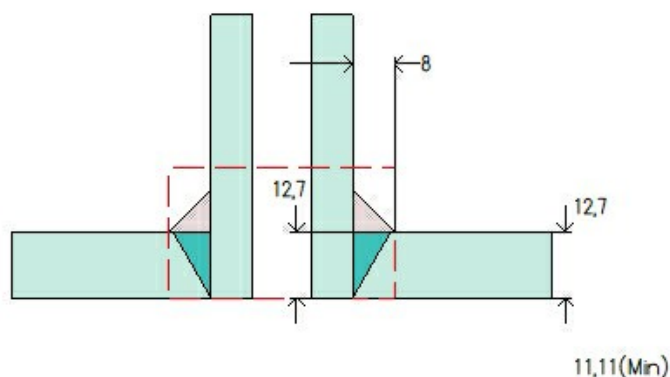

Note: round inside edges per UG-76(c)

Location and Orientation

Located on	B16.9 Pipe Cap - Right Side
Orientation	0°
End of nozzle to datum line	-166 mm
Calculated as hillside	No
Distance to head center, R	0 mm
Passes through a Category A joint	No

Nozzle

Description	NPS 0,75 XXS DN 20
Access opening	No
Material specification	SA-106 B Smls Pipe (II-D Metric p. 16, In. 16)
Inside diameter, new	11,02 mm
Pipe nominal wall thickness	7,82 mm
Pipe minimum wall thickness ¹	6,85 mm
Corrosion allowance	3 mm
Projection available outside vessel, L _{pr}	64,44 mm
Local vessel minimum thickness	11,11 mm
Liquid static head included	0 bar

Welds

Inner fillet, Leg ₄₁	8 mm
Nozzle to vessel groove weld	12,7 mm

Radiography

Longitudinal seam	Seamless No RT
Circumferential seam	Full UW-11(a) Type 1

¹Pipe minimum thickness = nominal thickness times pipe tolerance factor of 0,875.

UCS-66 Material Toughness Requirements Nozzle

$t_r = \frac{40,92 \cdot 8,51}{1,180 \cdot 1 - 0,6 \cdot 40,92} =$	0,3 mm
Stress ratio $= \frac{t_r \cdot E^*}{t_n - c} = \frac{0,3 \cdot 1}{6,85 - 3} =$	0,0784
Stress ratio $\leq 0,35$, MDMT per UCS-66(b)(3) =	-105°C
Material is exempt from impact testing at the Design MDMT of 0°C.	

Reinforcement Calculations for Internal Pressure

UG-37 Area Calculation Summary (cm ²)							UG-45 Summary (mm)	
For P = 39 bar @ 157 °C							The nozzle passes UG-45	
A required	A available	A ₁	A ₂	A ₃	A ₅	A welds	t _{req}	t _{min}
This nozzle is exempt from area calculations per UG-36(c)(3)(a)							5,51	6,85

UG-41 Weld Failure Path Analysis Summary
The nozzle is exempt from weld strength calculations per UW-15(b)(2)

UW-16 Weld Sizing Summary			
Weld description	Required weld throat size (mm)	Actual weld throat size (mm)	Status
Nozzle to shell fillet (Leg ₄₁)	3,38	5,6	weld size is adequate

Calculations for internal pressure 39 bar @ 157 °C

Parallel Limit of reinforcement per UG-40

$$\begin{aligned}
 L_R &= \max [d, R_n + (t_n - C_n) + (t - C)] \\
 &= \max [17,02, 8,51 + (7,82 - 3) + (11,11 - 3)] \\
 &= 21,45 \text{ mm}
 \end{aligned}$$

Outer Normal Limit of reinforcement per UG-40

$$\begin{aligned}
 L_H &= \min [2,5 \cdot (t - C), 2,5 \cdot (t_n - C_n) + t_e] \\
 &= \min [2,5 \cdot (11,11 - 3), 2,5 \cdot (7,82 - 3) + 0] \\
 &= 12,06 \text{ mm}
 \end{aligned}$$

Nozzle required thickness per UG-27(c)(1)

$$\begin{aligned}
 t_{rn} &= \frac{P \cdot R_n}{S_n \cdot E - 0,6 \cdot P} \\
 &= \frac{39,0001 \cdot 8,51}{1,180 \cdot 1 - 0,6 \cdot 39,0001} \\
 &= 0,29 \text{ mm}
 \end{aligned}$$

Required thickness t_r from UG-37(a)(c)

$$\begin{aligned}
 t_r &= \frac{P \cdot K_1 \cdot D_o}{2 \cdot S \cdot E + 0,8 \cdot P} \\
 &= \frac{39,0001 \cdot 0,8737 \cdot 219,07}{2 \cdot 1,180 \cdot 1 + 0,8 \cdot 39,0001} \\
 &= 3,12 \text{ mm}
 \end{aligned}$$

Required thickness t_r per Interpretation VIII-1-07-50

$$t_r = \frac{P \cdot D_o \cdot K}{2 \cdot S \cdot E + 2 \cdot P \cdot (K - 0,1)} = \frac{39 \cdot 219,07 \cdot 0,961673}{2 \cdot 1,180 \cdot 0,85 + 2 \cdot 39 \cdot (0,961673 - 0,1)} = 3,96 \text{ mm}$$

This opening does not require reinforcement per UG-36(c)(3)(a)

UW-16(c) Weld Check

Fillet weld: $t_{\min} = \min [19\text{mm}, t_n, t] = 4,82 \text{ mm}$

$$t_{c(\min)} = \min [6 \text{ mm}, 0,7 \cdot t_{\min}] = \underline{3,38} \text{ mm}$$

$$t_{c(\text{actual})} = 0,7 \cdot \text{Leg} = 0,7 \cdot 8 = 5,6 \text{ mm}$$

The fillet weld size is satisfactory.

Weld strength calculations are not required for this detail which conforms to Fig. UW-16.1, sketch (c-e).

UG-45 Nozzle Neck Thickness Check

Interpretation VIII-1-83-66 has been applied.

$$\begin{aligned} t_{aUG-27} &= \frac{P \cdot R_n}{S_n \cdot E - 0,6 \cdot P} + \text{Corrosion} \\ &= \frac{39,0001 \cdot 8,51}{1.180 \cdot 1 - 0,6 \cdot 39,0001} + 3 \\ &= 3,29 \text{ mm} \end{aligned}$$

$$\begin{aligned} t_a &= \max [t_{aUG-27}, t_{aUG-22}] \\ &= \max [3,29, 0] \\ &= 3,29 \text{ mm} \end{aligned}$$

$$\begin{aligned} t_{b1} &= \frac{P \cdot D_o \cdot K}{2 \cdot S \cdot E + 2 \cdot P \cdot (K - 0,1)} + \text{Corrosion} \\ &= \frac{39 \cdot 219,07 \cdot 0,961673}{2 \cdot 1.180 \cdot 1 + 2 \cdot 39 \cdot (0,961673 - 0,1)} + 3 \\ &= 6,38 \text{ mm} \end{aligned}$$

$$\begin{aligned} t_{b1} &= \max [t_{b1}, t_{bUG16}] \\ &= \max [6,39, 4,5] \\ &= 6,39 \text{ mm} \end{aligned}$$

$$\begin{aligned} t_b &= \min [t_{b3}, t_{b1}] \\ &= \min [5,51, 6,39] \\ &= 5,51 \text{ mm} \end{aligned}$$

$$\begin{aligned} t_{UG-45} &= \max [t_a, t_b] \\ &= \max [3,29, 5,51] \\ &= \underline{5,51} \text{ mm} \end{aligned}$$

Available nozzle wall thickness new, $t_n = 0,875 \cdot 7,82 = 6,85 \text{ mm}$

The nozzle neck thickness is adequate.

Reinforcement Calculations for MAWP

The vessel wall thickness governs the MAWP of this nozzle.

UG-37 Area Calculation Summary (cm ²)							UG-45 Summary (mm)	
For P = 103,54 bar @ 157 °C							The nozzle passes UG-45	
A required	A available	A ₁	A ₂	A ₃	A ₅	A welds	t _{req}	t _{min}
This nozzle is exempt from area calculations per UG-36(c)(3)(a)							5,51	6,85

UG-41 Weld Failure Path Analysis Summary
The nozzle is exempt from weld strength calculations per UW-15(b)(2)

UW-16 Weld Sizing Summary			
Weld description	Required weld throat size (mm)	Actual weld throat size (mm)	Status
Nozzle to shell fillet (Leg ₄₁)	3,38	5,6	weld size is adequate

Calculations for internal pressure 103,54 bar @ 157 °C

Parallel Limit of reinforcement per UG-40

$$\begin{aligned}
 L_R &= \max [d, R_n + (t_n - C_n) + (t - C)] \\
 &= \max [17,02, 8,51 + (7,82 - 3) + (11,11 - 3)] \\
 &= 21,45 \text{ mm}
 \end{aligned}$$

Outer Normal Limit of reinforcement per UG-40

$$\begin{aligned}
 L_H &= \min [2,5 \cdot (t - C), 2,5 \cdot (t_n - C_n) + t_e] \\
 &= \min [2,5 \cdot (11,11 - 3), 2,5 \cdot (7,82 - 3) + 0] \\
 &= 12,06 \text{ mm}
 \end{aligned}$$

Nozzle required thickness per UG-27(c)(1)

$$\begin{aligned}
 t_{rn} &= \frac{P \cdot R_n}{S_n \cdot E - 0,6 \cdot P} \\
 &= \frac{103,5405 \cdot 8,51}{1.180 \cdot 1 - 0,6 \cdot 103,5405} \\
 &= 0,79 \text{ mm}
 \end{aligned}$$

Required thickness t_r from UG-37(a)(c)

$$\begin{aligned}
 t_r &= \frac{P \cdot K_1 \cdot D_o}{2 \cdot S \cdot E + 0,8 \cdot P} \\
 &= \frac{103,5405 \cdot 0,8737 \cdot 219,07}{2 \cdot 1.180 \cdot 1 + 0,8 \cdot 103,5405} \\
 &= 8,11 \text{ mm}
 \end{aligned}$$

Required thickness t_r per Interpretation VIII-1-07-50

$$t_r = \frac{P \cdot D_o \cdot K}{2 \cdot S \cdot E + 2 \cdot P \cdot (K - 0,1)} = \frac{103,54 \cdot 219,07 \cdot 0,961673}{2 \cdot 1.180 \cdot 0,85 + 2 \cdot 103,54 \cdot (0,961673 - 0,1)} = 9,99 \text{ mm}$$

This opening does not require reinforcement per UG-36(c)(3)(a)

UW-16(c) Weld Check

Fillet weld: $t_{\min} = \min [19\text{mm}, t_n, t] = 4,82 \text{ mm}$

$t_{c(\min)} = \min [6 \text{ mm}, 0,7 \cdot t_{\min}] = 3,38 \text{ mm}$

$t_{c(\text{actual})} = 0,7 \cdot \text{Leg} = 0,7 \cdot 8 = 5,6 \text{ mm}$

The fillet weld size is satisfactory.

Weld strength calculations are not required for this detail which conforms to Fig. UW-16.1, sketch (c-e).

UG-45 Nozzle Neck Thickness Check

Interpretation VIII-1-83-66 has been applied.

$$\begin{aligned} t_{aUG-27} &= \frac{P \cdot R_n}{S_n \cdot E - 0,6 \cdot P} + \text{Corrosion} \\ &= \frac{103,5405 \cdot 8,51}{1,180 \cdot 1 - 0,6 \cdot 103,5405} + 3 \\ &= 3,79 \text{ mm} \end{aligned}$$

$$\begin{aligned} t_a &= \max [t_{aUG-27}, t_{aUG-22}] \\ &= \max [3,79, 0] \\ &= 3,79 \text{ mm} \end{aligned}$$

$$\begin{aligned} t_{b1} &= \frac{P \cdot D_o \cdot K}{2 \cdot S \cdot E + 2 \cdot P \cdot (K - 0,1)} + \text{Corrosion} \\ &= \frac{103,54 \cdot 219,07 \cdot 0,961673}{2 \cdot 1,180 \cdot 1 + 2 \cdot 103,54 \cdot (0,961673 - 0,1)} + 3 \\ &= 11,59 \text{ mm} \end{aligned}$$

$$\begin{aligned} t_{b1} &= \max [t_{b1}, t_{bUG16}] \\ &= \max [11,59, 4,5] \\ &= 11,59 \text{ mm} \end{aligned}$$

$$\begin{aligned} t_b &= \min [t_{b3}, t_{b1}] \\ &= \min [5,51, 11,59] \\ &= 5,51 \text{ mm} \end{aligned}$$

$$\begin{aligned} t_{UG-45} &= \max [t_a, t_b] \\ &= \max [3,79, 5,51] \\ &= 5,51 \text{ mm} \end{aligned}$$

Available nozzle wall thickness new, $t_n = 0,875 \cdot 7,82 = 6,85 \text{ mm}$

The nozzle neck thickness is adequate.

Reinforcement Calculations for MAP

The vessel wall thickness governs the MAP of this nozzle.

UG-37 Area Calculation Summary (cm ²)							UG-45 Summary (mm)	
For P = 139,29 bar @ 21,11 °C							The nozzle passes UG-45	
A required	A available	A ₁	A ₂	A ₃	A ₅	A welds	t _{req}	t _{min}
This nozzle is exempt from area calculations per UG-36(c)(3)(a)							2,51	6,85

UG-41 Weld Failure Path Analysis Summary
The nozzle is exempt from weld strength calculations per UW-15(b)(2)

Calculations for internal pressure 139,29 bar @ 21,11 °C

Parallel Limit of reinforcement per UG-40

$$\begin{aligned}
 L_R &= \max [d, R_n + (t_n - C_n) + (t - C)] \\
 &= \max [11,02, 5,51 + (7,82 - 0) + (11,11 - 0)] \\
 &= 24,45 \text{ mm}
 \end{aligned}$$

Outer Normal Limit of reinforcement per UG-40

$$\begin{aligned}
 L_H &= \min [2,5 \cdot (t - C), 2,5 \cdot (t_n - C_n) + t_e] \\
 &= \min [2,5 \cdot (11,11 - 0), 2,5 \cdot (7,82 - 0) + 0] \\
 &= 19,56 \text{ mm}
 \end{aligned}$$

Nozzle required thickness per UG-27(c)(1)

$$\begin{aligned}
 t_{rn} &= \frac{P \cdot R_n}{S_n \cdot E - 0,6 \cdot P} \\
 &= \frac{139,2932 \cdot 5,51}{1.180 \cdot 1 - 0,6 \cdot 139,2932} \\
 &= 0,7 \text{ mm}
 \end{aligned}$$

Required thickness t_r from UG-37(a)(c)

$$\begin{aligned}
 t_r &= \frac{P \cdot K_1 \cdot D_o}{2 \cdot S \cdot E + 0,8 \cdot P} \\
 &= \frac{139,2932 \cdot 0,9 \cdot 219,07}{2 \cdot 1.180 \cdot 1 + 0,8 \cdot 139,2932} \\
 &= 11,11 \text{ mm}
 \end{aligned}$$

Required thickness t_r per Interpretation VIII-1-07-50

$$t_r = \frac{P \cdot D_o \cdot K}{2 \cdot S \cdot E + 2 \cdot P \cdot (K - 0,1)} = \frac{139,29 \cdot 219,07 \cdot 1}{2 \cdot 1.180 \cdot 0,85 + 2 \cdot 139,29 \cdot (1 - 0,1)} = 13,52 \text{ mm}$$

This opening does not require reinforcement per UG-36(c)(3)(a)

UG-45 Nozzle Neck Thickness Check

Interpretation VIII-1-83-66 has been applied.

$$\begin{aligned}t_{aUG-27} &= \frac{P \cdot R_n}{S_n \cdot E - 0,6 \cdot P} + \text{Corrosion} \\ &= \frac{139,2932 \cdot 5,51}{1.180 \cdot 1 - 0,6 \cdot 139,2932} + 0 \\ &= 0,7 \text{ mm}\end{aligned}$$

$$\begin{aligned}t_a &= \max [t_{aUG-27}, t_{aUG-22}] \\ &= \max [0,7, 0] \\ &= 0,7 \text{ mm}\end{aligned}$$

$$\begin{aligned}t_{b1} &= \frac{P \cdot D_o \cdot K}{2 \cdot S \cdot E + 2 \cdot P \cdot (K - 0,1)} + \text{Corrosion} \\ &= \frac{139,29 \cdot 219,07 \cdot 1}{2 \cdot 1.180 \cdot 1 + 2 \cdot 139,29 \cdot (1 - 0,1)} + 0 \\ &= 11,69 \text{ mm}\end{aligned}$$

$$\begin{aligned}t_{b1} &= \max [t_{b1}, t_{bUG16}] \\ &= \max [11,69, 1,5] \\ &= 11,69 \text{ mm}\end{aligned}$$

$$\begin{aligned}t_b &= \min [t_{b3}, t_{b1}] \\ &= \min [2,51, 11,69] \\ &= 2,51 \text{ mm}\end{aligned}$$

$$\begin{aligned}t_{UG-45} &= \max [t_a, t_b] \\ &= \max [0,7, 2,51] \\ &= 2,51 \text{ mm}\end{aligned}$$

Available nozzle wall thickness new, $t_n = 0,875 \cdot 7,82 = 6,85 \text{ mm}$

The nozzle neck thickness is adequate.

B16.9 Elbow #2 (N2)

ASME Section VIII Division 1, 2021 Edition Metric				
Component		ASME B16.9 Elbow		
Type		Long Radius 90-deg		
Material		SA-234 WPB (II-D Metric p. 16, In. 18)		
Pipe NPS and Schedule		NPS 0,75 XXS DN 20		
Attached To		Air Outlet (N2)		
Impact Tested	Normalized	Fine Grain Practice	PWHT	Maximize MDMT/ No MAWP
No	No	No	No	No
		Design Pressure (bar)	Design Temperature (°C)	Design MDMT (°C)
Internal		39	157	0
Static Liquid Head				
Condition		P_s (bar)	H_s (mm)	SG
Test horizontal		0,03	255,51	1
Dimensions				
Outer Diameter		26,67 mm		
Nominal Thickness		7,82 mm		
Minimum Thickness¹		6,85 mm		
Center-to-End, A		38 mm		
Corrosion	Inner	3 mm		
	Outer	0 mm		
Weight and Capacity				
		Weight (kg)	Capacity (liters)	
New		0,22	0,01	
Corroded		0,16	0,01	
Radiography				
Longitudinal seam		Seamless No RT		
Left Circumferential seam		Full UW-11(a) Type 1		
Right Circumferential seam		Full UW-11(a) Type 1		

¹ minimum thickness = nominal thickness times pipe tolerance factor of 0,875.

ASME B16.5-2017 Flange	
Description	NPS 0,75 Class 600 WN A105
Bolt Material	SA-193 B7 Bolt <= 64 (II-D Metric p. 410, In. 32)
Blind included	No
Rated MDMT	-48°C
Liquid static head	0 bar
MAWP rating	89,84 bar @ 157°C
MAP rating	102,1 bar @ 21,11°C
Hydrotest rating	154 bar @ 21,11°C
PWHT performed	No
Produced to Fine Grain Practice and Supplied in Heat Treated Condition	No
Impact Tested	No
Circumferential joint radiography	Full UW-11(a) Type 1
Bore diameter, B (specified by purchaser)	11,02 mm
Gasket	
Type	ASME B16.21 Nonmetallic Flat Gasket
Description	Flexitallic Compressed Fiber SF 2401 Synthetic/NBR
Factor, m	3,2
Seating Stress, y	203,89 kgf/cm ²
Thickness, T	3 mm
Inner Diameter	27 mm
Outer Diameter	67 mm
Notes	
Flange rated MDMT per UCS-66(b)(1)(b) = -48°C (Coincident ratio = 0,4008) Bolts rated MDMT per Fig UCS-66 note (c) = -48°C	

Results Summary	
Governing condition	UG-16
Minimum thickness per UG-16	1,5 mm + 3 mm = 4,5 mm
Design thickness due to internal pressure (t)	3.43 mm
Maximum allowable working pressure (MAWP)	401.45 bar
Maximum allowable pressure (MAP)	849.81 bar
Rated MDMT	-105 °C

UCS-66 Material Toughness Requirements	
$t_r = 13,34 \cdot \left(1 - \exp\left(-\frac{40,92}{1.180 \cdot 1} \right) \right) =$	0,45 mm
Stress ratio $= \frac{t_r \cdot E^*}{t_n - c} = \frac{0,45 \cdot 1}{6,85 - 3} =$	0,1182
Stress ratio $\leq 0,35$, MDMT per UCS-66(b)(3) =	-105°C
Material is exempt from impact testing at the Design MDMT of 0°C.	

Design thickness, (at 157 °C) Appendix 1-2

$$t = R_o \cdot \left(1 - \exp\left[-\frac{P}{S \cdot E} \right] \right) + \text{Corrosion} = 13,34 \cdot \left(1 - \exp\left[-\frac{39}{1.180 \cdot 1,00} \right] \right) + 3 = \text{3.43 mm}$$

Maximum allowable working pressure, (at 157 °C) Appendix 1-2

$$P = S \cdot E \cdot \ln\left(\frac{R_o}{R_o - t}\right) - P_s = 1.180 \cdot 1,00 \cdot \ln\left(\frac{13,34}{13,34 - (7,82 \cdot 0,875 - 3)}\right) - 0 = \underline{401,45} \text{ bar}$$

Maximum allowable pressure, (at 21,11 °C) Appendix 1-2

$$P = S \cdot E \cdot \ln\left(\frac{R_o}{R_o - t}\right) = 1.180 \cdot 1,00 \cdot \ln\left(\frac{13,34}{13,34 - (7,82 \cdot 0,875)}\right) = \underline{849,81} \text{ bar}$$

Locati Impianti Srl

Via Vittorio Veneto, 37 - Verdellino - Bergamo - Italy

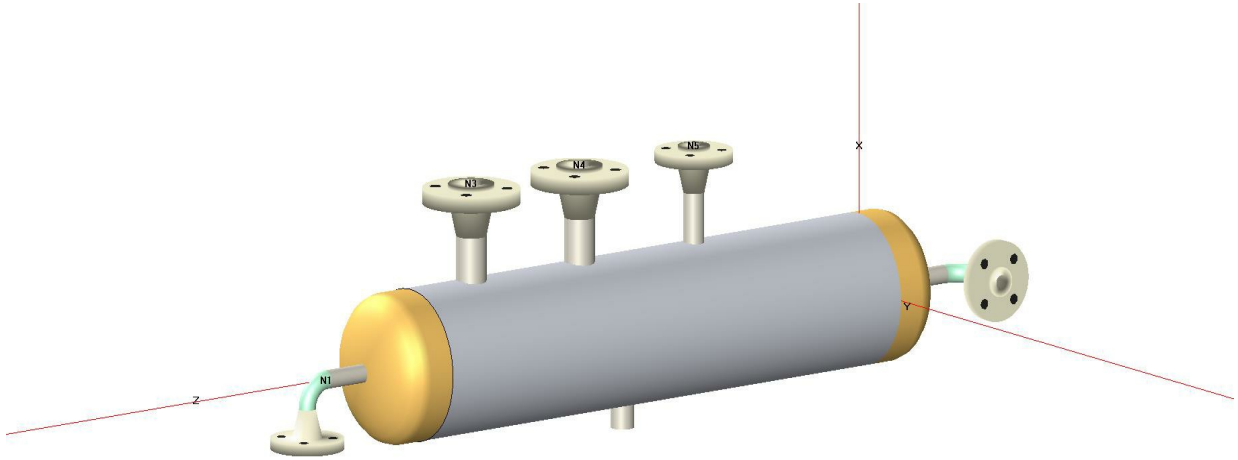

COMPRESS Pressure Vessel Design Calculations

Item: LI 5062

Customer: Airpack

Drawing No.: C230048DWG004

Document No.: C230048CLC008 Rev.05

Date: 04/10/2024

Service: 2nd Stage Outlet Pulsation Damper

Tag Number: 320-KV-020-004

Table of Contents

Nozzle Schedule	1
Nozzle Summary	2
Pressure Summary	3
Settings Summary	4
Radiography Summary	6
Thickness Summary	7
Weight Summary	8
Hydrostatic Test	9
B16.9 Pipe Cap - Left Side	10
Straight Flange on B16.9 Pipe Cap - Left Side	12
Air Inlet (N1)	14
B16.9 Elbow #1 (N1)	22
Cylinder #1	25
Temperature Gauge Connection (N3)	27
Temperature Transmitter Connection (N4)	37
PSV Connection (N5)	47
Drain (N6)	57
Straight Flange on B16.9 Pipe Cap - Right Side	64
B16.9 Pipe Cap - Right Side	66
Air Outlet (N2)	68
B16.9 Elbow #2 (N2)	76

Nozzle Schedule

Specifications									
Nozzle mark	Identifier	Size	Materials		Impact Tested	Normalized	Fine Grain	Flange	Blind
N1	Air Inlet	NPS 0,75 XXS DN 20	Nozzle	SA-106 B Smls Pipe	No	No	No	N/A	No
	B16.9 Elbow #1 (N1)	NPS 0,75 XXS DN 20	B16.9 Elbow	SA-234 WPB	No	No	No	NPS 3/4 Class 600 WN A105	No
N2	Air Outlet	NPS 0,75 XXS DN 20	Nozzle	SA-106 B Smls Pipe	No	No	No	N/A	No
	B16.9 Elbow #2 (N2)	NPS 0,75 XXS DN 20	B16.9 Elbow	SA-234 WPB	No	No	No	NPS 3/4 Class 600 WN A105	No
N3	Temperature Gauge Connection	NPS 1,5 Sch 160 DN 40	Nozzle	SA-106 B Smls Pipe	No	No	No	NPS 1 1/2 Class 600 WN A105	No
N4	Temperature Transmitter Connection	NPS 1,5 Sch 160 DN 40	Nozzle	SA-106 B Smls Pipe	No	No	No	NPS 1 1/2 Class 600 WN A105	No
N5	PSV Connection	NPS 1 XXS DN 25	Nozzle	SA-106 B Smls Pipe	No	No	No	NPS 1 Class 600 WN A105	No
N6	Drain	NPS 0,5 Class 6000 DN 15 - Threaded Full Coupling	Nozzle	SA-105	No	No	No	N/A	No

Nozzle Summary

Dimensions												
Nozzle mark	OD (mm)	t _n (mm)	Req t _n (mm)	A ₁ ?	A ₂ ?	Shell			Reinforcement Pad		Corr (mm)	A _a /A _r (%)
						Nom t (mm)	Design t (mm)	User t (mm)	Width (mm)	t _{pad} (mm)		
N1	26,67	7,82	6,3	Yes	Yes	12,7	N/A		N/A	N/A	3	Exempt
N2	26,67	7,82	6,3	Yes	Yes	12,7	N/A		N/A	N/A	3	Exempt
N3	48,26	7,14	7,11	Yes	Yes	12,7	N/A		N/A	N/A	3	Exempt
N4	48,26	7,14	7,11	Yes	Yes	12,7	N/A		N/A	N/A	3	Exempt
N5	33,4	9,09	6,81	Yes	Yes	12,7	N/A		N/A	N/A	3	Exempt
N6	38,1	8,38	4,5	Yes	Yes	12,7	N/A		N/A	N/A	3	Exempt

*Head minimum thickness after forming

Definitions	
t _n	Nozzle thickness
Req t _n	Nozzle thickness required per UG-45/UG-16 Increased for pipe to account for 12.5% pipe thickness tolerance
Nom t	Vessel wall thickness
Design t	Required vessel wall thickness due to pressure + corrosion allowance per UG-37
User t	Local vessel wall thickness (near opening)
A _a	Area available per UG-37, governing condition
A _r	Area required per UG-37, governing condition
Corr	Corrosion allowance on nozzle wall

Pressure Summary

Component Summary							
Identifier	P Design (bar)	T Design (°C)	MAWP (bar)	MAP (bar)	MDMT (°C)	MDMT Exemption	Impact Tested
B16.9 Pipe Cap - Left Side	39	135	82,74	111,98	-48	Note 1	No
Straight Flange on B16.9 Pipe Cap - Left Side	39	135	92,09	121,95	-48	Note 2	No
Cylinder #1	39	135	76,56	106,06	-45,68	Note 3	No
Straight Flange on B16.9 Pipe Cap - Right Side	39	135	92,09	121,95	-48	Note 2	No
B16.9 Pipe Cap - Right Side	39	135	82,74	111,98	-48	Note 4	No
Air Inlet (N1)	39	135	103,54	139,29	-105	Note 5	No
B16.9 Elbow #1 (N1)	39	135	91,1	102,1	-44,78	Note 6, 7	No
Air Outlet (N2)	39	135	103,54	139,29	-105	Note 5	No
B16.9 Elbow #2 (N2)	39	135	91,1	102,1	-44,78	Note 6, 7	No
Temperature Gauge Connection (N3)	39	135	90,07	102,1	-44,78	Note 8	No
Temperature Transmitter Connection (N4)	39	135	90,07	102,1	-44,78	Note 8	No
PSV Connection (N5)	39	135	90,07	102,1	-44,78	Note 8	No
Drain (N6)	39	135	90,07	124,78	-105	Note 9	No

Chamber Summary	
Design MDMT	0 °C
Rated MDMT	0 °C @ 56,38 bar
MAWP hot & corroded	56,38 bar @ 135 °C
MAP cold & new	102,1 bar @ 21,11 °C

(1) The MAWP is limited due to the MAWP limit set in the Calculations tab of the Set Mode dialog.
(2) The rated MDMT is limited to the design MDMT based on the setting in the Calculations tab of the Set Mode dialog.
(3) This pressure chamber is not designed for external pressure.

Notes for MDMT Rating		
Note #	Exemption	Details
1.	Straight Flange governs MDMT	
2.	Material impact test exemption temperature from Fig UCS-66M Curve B = -24,98°C Fig UCS-66.1M MDMT reduction = 28,9°C, (coincident ratio = 0,5277) Rated MDMT of -53,88°C is limited to -48°C by UCS-66(b)(2)	UCS-66 governing thickness = 11,11 mm
3.	Material impact test exemption temperature from Fig UCS-66M Curve B = -24,98°C Fig UCS-66.1M MDMT reduction = 20,7°C, (coincident ratio = 0,6309)	UCS-66 governing thickness = 11,11 mm
4.	Straight Flange governs MDMT	
5.	Nozzle is impact test exempt to -105°C per UCS-66(b)(3) (coincident ratio = 0,1089).	
6.	Material is impact test exempt to -105°C per UCS-66(b)(3) (coincident ratio = 0,1618)	
7.	Flange rating governs: Flange rated MDMT per UCS-66(b)(1)(b) = -44,78°C (Coincident ratio = 0,5522)	Bolts rated MDMT per Fig UCS-66 note (c) = -48°C
8.	Flange rating governs: Flange rated MDMT per UCS-66(b)(1)(b) = -44,78°C (Coincident ratio = 0,5522) Bolts rated MDMT per Fig UCS-66 note (c) = -48°C	
9.	Nozzle is impact test exempt to -105°C per UCS-66(b)(3) (coincident ratio = 0,1064).	

Settings Summary

COMPRESS 2024 Build 8400	
ASME Section VIII Division 1, 2021 Edition Metric	
Units	MKS
Datum Line Location	0,00 mm from right seam
Vessel Design Mode	Design Mode
Minimum thickness	1,5 mm per UG-16(b)
Design for cold shut down only	No
Design for lethal service (full radiography required)	No
User has limited MAWP to	56,38 bar
Design nozzles for	Design P only
Corrosion weight loss	100% of theoretical loss
UG-23 Stress Increase	1,20
Skirt/legs stress increase	1,0
Minimum nozzle projection	60 mm
Juncture calculations for $\alpha > 30$ only	Yes
Preheat P-No 1 Materials > 1,25" and <= 1,50" thick	No
UG-37(a) shell tr calculation considers longitudinal stress	No
Cylindrical shells made from pipe are entered as minimum thickness	No
Nozzles made from pipe are entered as minimum thickness	No
ASME B16.9 fittings are entered as minimum thickness	No
Butt welds	Tapered per Figure UCS-66.3(a)
Disallow Appendix 1-5, 1-8 calculations under 15 psi	No
Hydro/Pneumatic Test	
Shop Hydrotest Pressure	1,3 times vessel MAWP [UG-99(b)]
Test liquid specific gravity	1,00
Maximum stress during test	90% of yield
Required Marking - UG-116	
UG-116(e) Radiography	RT3
UG-116(f) Postweld heat treatment	None
Code Cases/Interpretations	
Use Appendix 46	No
Use UG-44(b)	No
Use Code Case 3035	No
Apply interpretation VIII-1-83-66	Yes
Apply interpretation VIII-1-86-175	Yes
Apply interpretation VIII-1-01-37	Yes
Apply interpretation VIII-1-01-150	Yes
Apply interpretation VIII-1-07-50	Yes
Apply interpretation VIII-1-16-85	Yes
No UCS-66.1 MDMT reduction	No
No UCS-68(c) MDMT reduction	No
Disallow UG-20(f) exemptions	No
UG-22 Loadings	
UG-22(a) Internal or External Design Pressure	Yes
UG-22(b) Weight of the vessel and normal contents under operating or test conditions	No
UG-22(c) Superimposed static reactions from weight of attached equipment (external loads)	No
UG-22(d)(2) Vessel supports such as lugs, rings, skirts, saddles and legs	No
UG-22(f) Wind reactions	No
UG-22(f) Seismic reactions	No

UG-22(j) Test pressure and coincident static head acting during the test:	No
Note: UG-22(b),(c) and (f) loads only considered when supports are present.	
Note 2: UG-22(d)(1),(e),(f)-snow,(g),(h),(i) are not considered. If these loads are present, additional calculations must be performed.	

License Information	
Company Name	Locati Impianti s.r.l.
License	Commercial
License Key ID	32235
Support Expires	September 20, 2025
Account Number	891888909529634

Radiography Summary

UG-116 Radiography							
Component	Longitudinal Seam		Left Circumferential Seam		Right Circumferential Seam		Mark
	Category (Fig UW-3)	Radiography / Joint Type	Category (Fig UW-3)	Radiography / Joint Type	Category (Fig UW-3)	Radiography / Joint Type	
B16.9 Pipe Cap - Left Side	N/A	Seamless No RT	N/A	N/A	B	Spot UW-11(b) / Type 1	RT3
Cylinder #1	N/A	Seamless No RT	B	Spot UW-11(b) / Type 1	B	Spot UW-11(b) / Type 1	RT3
B16.9 Pipe Cap - Right Side	N/A	Seamless No RT	B	Spot UW-11(b) / Type 1	N/A	N/A	RT3
Nozzle	Longitudinal Seam		Nozzle to Vessel Circumferential Seam		Nozzle free end Circumferential Seam		
Air Inlet (N1)	N/A	Seamless No RT	D	N/A / Type 7	B	UW-11(b) exempt / Type 1	N/A
B16.9 Elbow #1 (N1)	N/A	Seamless No RT	B	UW-11(b) exempt / Type 1	C	UW-11(b) exempt / Type 1	N/A
Temperature Gauge Connection (N3)	N/A	Seamless No RT	D	N/A / Type 7	C	UW-11(b) exempt / Type 1	N/A
Temperature Transmitter Connection (N4)	N/A	Seamless No RT	D	N/A / Type 7	C	UW-11(b) exempt / Type 1	N/A
PSV Connection (N5)	N/A	Seamless No RT	D	N/A / Type 7	C	UW-11(b) exempt / Type 1	N/A
Drain (N6)	N/A	Seamless No RT	D	N/A / Type 7	N/A	N/A	N/A
Air Outlet (N2)	N/A	Seamless No RT	D	N/A / Type 7	B	UW-11(b) exempt / Type 1	N/A
B16.9 Elbow #2 (N2)	N/A	Seamless No RT	B	UW-11(b) exempt / Type 1	C	UW-11(b) exempt / Type 1	N/A
Nozzle Flange	Longitudinal Seam		Flange Face		Nozzle to Flange Circumferential Seam		
ASME B16.5/16.47 flange attached to right end of B16.9 Elbow #1 (N1)	N/A	Seamless No RT	N/A	N/A / Gasketed	C	UW-11(b) exempt / Type 1	N/A
ASME B16.5/16.47 flange attached to Temperature Gauge Connection (N3)	N/A	Seamless No RT	N/A	N/A / Gasketed	C	UW-11(b) exempt / Type 1	N/A
ASME B16.5/16.47 flange attached to Temperature Transmitter Connection (N4)	N/A	Seamless No RT	N/A	N/A / Gasketed	C	UW-11(b) exempt / Type 1	N/A
ASME B16.5/16.47 flange attached to PSV Connection (N5)	N/A	Seamless No RT	N/A	N/A / Gasketed	C	UW-11(b) exempt / Type 1	N/A
ASME B16.5/16.47 flange attached to right end of B16.9 Elbow #2 (N2)	N/A	Seamless No RT	N/A	N/A / Gasketed	C	UW-11(b) exempt / Type 1	N/A
UG-116(e) Required Marking: RT3							

Thickness Summary

Component Data								
Component Identifier	Material	Diameter (mm)	Length (mm)	Nominal t (mm)	Design t (mm)	Total Corrosion (mm)	Joint E	Load
B16.9 Pipe Cap - Left Side	SA-234 WPB	219,07 OD	59,53	12,7	6,96	3	0,85	Internal
Straight Flange on B16.9 Pipe Cap - Left Side	SA-234 WPB	219,07 OD	42,47	12,7	7,2	3	0,85	Internal
Cylinder #1	SA-106 B Smls Pipe	219,07 OD	890	12,7	7,2	3	0,85	Internal
Straight Flange on B16.9 Pipe Cap - Right Side	SA-234 WPB	219,07 OD	42,47	12,7	7,2	3	0,85	Internal
B16.9 Pipe Cap - Right Side	SA-234 WPB	219,07 OD	59,53	12,7	6,96	3	0,85	Internal

Definitions	
Nominal t	Vessel wall nominal thickness
Design t	Required vessel thickness due to governing loading + corrosion
Joint E	Longitudinal seam joint efficiency
Load	
Internal	Circumferential stress due to internal pressure governs
External	External pressure governs
Wind	Combined longitudinal stress of pressure + weight + wind governs
Seismic	Combined longitudinal stress of pressure + weight + seismic governs

Weight Summary

Weight (kg) Contributed by Vessel Elements											
Component	Metal New*	Metal Corroded	Insulation	Insulation Supports	Lining	Piping + Liquid	Operating Liquid		Test Liquid		Surface Area m ²
							New	Corroded	New	Corroded	
B16.9 Pipe Cap - Left Side	7,7	6,1	0	0	0	0	0	0	2,2	2,4	0,09
Cylinder #1	56,8	44	0	0	0	0	0	0	26,3	28,1	0,61
B16.9 Pipe Cap - Right Side	7,7	6,1	0	0	0	0	0	0	2,2	2,4	0,09
TOTAL:	72,3	56,2	0	0	0	0	0	0	30,8	32,9	0,78

*Shells with attached nozzles have weight reduced by material cut out for opening.

Weight (kg) Contributed by Attachments										
Component	Body Flanges		Nozzles & Flanges		Packed Beds	Trays	Tray Supports	Rings & Clips	Vertical Loads	Surface Area m ²
	New	Corroded	New	Corroded						
B16.9 Pipe Cap - Left Side	0	0	2,3	2,2	0	0	0	0	0	0,03
Cylinder #1	0	0	11	10,3	0	0	0	0	0	0,16
B16.9 Pipe Cap - Right Side	0	0	2,3	2,2	0	0	0	0	0	0,03
TOTAL:	0	0	15,6	14,6	0	0	0	0	0	0,23

Vessel Totals		
	New	Corroded
Operating Weight (kg)	88	71
Empty Weight (kg)	88	71
Test Weight (kg)	119	104
Surface Area (m ²)	1,01	-
Capacity** (liters)	31	33

**The vessel capacity does not include volume of nozzle, piping or other attachments.

Vessel Lift Condition	
Vessel Lift Weight, New (kg)	88
Center of Gravity from Datum (mm)	463,56

Hydrostatic Test

Horizontal shop hydrostatic test based on MAWP per UG-99(b)

$$\begin{aligned}
 \text{Gauge pressure at } 21,11^{\circ}\text{C} &= 1,3 \cdot MAWP \cdot LSR \\
 &= 1,3 \cdot 56,38 \cdot 1 \\
 &= 73,29 \text{ bar}
 \end{aligned}$$

Horizontal shop hydrostatic test				
Identifier	Local test pressure (bar)	Test liquid static head (bar)	UG-99(b) stress ratio	UG-99(b) pressure factor
B16.9 Pipe Cap - Left Side (1)	73,33	0,03	1	1,30
Straight Flange on B16.9 Pipe Cap - Left Side	73,33	0,03	1	1,30
Cylinder #1	73,33	0,03	1	1,30
Straight Flange on B16.9 Pipe Cap - Right Side	73,33	0,03	1	1,30
B16.9 Pipe Cap - Right Side	73,33	0,03	1	1,30
Air Inlet (N1)	73,32	0,03	1	1,30
Air Outlet (N2)	73,32	0,03	1	1,30
B16.9 Elbow #1 (N1)	73,32	0,03	1	1,30
B16.9 Elbow #2 (N2)	73,32	0,03	1	1,30
Drain (N6)	73,33	0,04	1	1,30
PSV Connection (N5)	73,31	0,01	1	1,30
Temperature Gauge Connection (N3)	73,31	0,01	1	1,30
Temperature Transmitter Connection (N4)	73,31	0,01	1	1,30
(1) B16.9 Pipe Cap - Left Side limits the UG-99(b) stress ratio. (2) The zero degree angular position is assumed to be up, and the test liquid height is assumed to the top-most flange.				

The field test condition has not been investigated.

The test temperature of 21,11 °C is warmer than the minimum recommended temperature of -27,78 °C so the brittle fracture provision of UG-99(h) has been met.

B16.9 Pipe Cap - Left Side

ASME Section VIII Division 1, 2021 Edition Metric				
Component		ASME B16.9 Pipe Cap (modified)		
Material		SA-234 WPB (II-D Metric p. 16, In. 18)		
Attached To		Cylinder #1		
Impact Tested	Normalized	Fine Grain Practice	PWHT	Maximize MDMT/ No MAWP
No	No	No	No	No
		Design Pressure (bar)	Design Temperature (°C)	Design MDMT (°C)
Internal		39	135	0
Static Liquid Head				
Condition		P_s (bar)	H_s (mm)	SG
Test horizontal		0,03	346,84	1
Dimensions				
NPS and Schedule		NPS 8 Sch 80 (XS) DN 200		
Outer Diameter		219,07 mm		
Overall Length E		102 mm		
Nominal Thickness		12,7 mm		
Minimum Thickness¹		11,11 mm		
Corrosion	Inner	3 mm		
	Outer	0 mm		
Length L_{sf}		42,47 mm		
Nominal Thickness t_{sf}		12,7 mm		
Weight and Capacity				
		Weight (kg)²	Capacity (liters)²	
New		7,72	2,2	
Corroded		6,06	2,4	
Radiography				
Category A joints		Seamless No RT		
Head to shell seam		Spot UW-11(b) Type 1		

¹ minimum thickness = nominal thickness times pipe tolerance factor of 0,875.

² includes straight flange

Results Summary	
Governing condition	internal pressure
Minimum thickness per UG-16	1,5 mm + 3 mm = 4,5 mm
Design thickness due to internal pressure (t)	<u>6,96</u> mm
Governing straight flange design thickness	7,2 mm
Maximum allowable working pressure (MAWP)	<u>82,74</u> bar
Maximum allowable pressure (MAP)	<u>111,98</u> bar
<u>Straight Flange</u> governs MDMT	-48°C

Factor K		
	$K = \left(\frac{1}{6}\right) \cdot \left[2 + \left(\frac{D}{2 \cdot h}\right)^2\right]$	
Corroded	$K = \left(\frac{1}{6}\right) \cdot \left[2 + \left(\frac{199,67}{2 \cdot 51,42}\right)^2\right]$	0,9617
New	$K = \left(\frac{1}{6}\right) \cdot \left[2 + \left(\frac{193,67}{2 \cdot 48,42}\right)^2\right]$	1

Design thickness for internal pressure, (Corroded at 135 °C) Appendix 1-4(c)

$$t = \frac{P \cdot D_o \cdot K}{2 \cdot S \cdot E + 2 \cdot P \cdot (K - 0,1)} + \text{Corrosion} = \frac{39 \cdot 219,07 \cdot 0,961673}{2 \cdot 1.180 \cdot 0,85 + 2 \cdot 39 \cdot (0,961673 - 0,1)} + 3 = 6.96 \text{ mm}$$

Maximum allowable working pressure, (Corroded at 135 °C) Appendix 1-4(c)

$$P = \frac{2 \cdot S \cdot E \cdot t}{K \cdot D_o - 2 \cdot t \cdot (K - 0,1)} - P_s = \frac{2 \cdot 1.180 \cdot 0,85 \cdot (0,875 \cdot 12,7 - 3)}{0,961673 \cdot 219,07 - 2 \cdot (0,875 \cdot 12,7 - 3) \cdot (0,961673 - 0,1)} - 0 = 82.74 \text{ bar}$$

Maximum allowable pressure, (New at 21,11 °C) Appendix 1-4(c)

$$P = \frac{2 \cdot S \cdot E \cdot t}{K \cdot D_o - 2 \cdot t \cdot (K - 0,1)} - P_s = \frac{2 \cdot 1.180 \cdot 0,85 \cdot 0,875 \cdot 12,7}{1 \cdot 219,07 - 2 \cdot 0,875 \cdot 12,7 \cdot (1 - 0,1)} - 0 = 111.98 \text{ bar}$$

ASME Section VIII Division 1 UG-81(a) Out-of-Roundness
Inside surface shall not deviate outside the shape by more than 1,25 % of D
Inside surface shall not deviate inside the shape by more than 0,625 % of D

Straight Flange on B16.9 Pipe Cap - Left Side

ASME Section VIII Division 1, 2021 Edition Metric				
Component		Cylinder		
Material		SA-234 WPB (II-D Metric p. 16, ln. 18)		
Impact Tested	Normalized	Fine Grain Practice	PWHT	Maximize MDMT/ No MAWP
No	No	No	No	No
		Design Pressure (bar)	Design Temperature (°C)	Design MDMT (°C)
Internal		39	135	0
Static Liquid Head				
Condition		P_s (bar)	H_s (mm)	SG
Test horizontal		0,03	346,84	1
Dimensions				
Outer Diameter		219,07 mm		
Length		42,47 mm		
Nominal Thickness		12,7 mm		
Corrosion	Inner	3 mm		
	Outer	0 mm		
Weight and Capacity				
		Weight (kg)	Capacity (liters)	
New		2,74	1,25	
Corroded		2,12	1,33	
Radiography				
Longitudinal seam		Seamless No RT		
Right Circumferential seam		Spot UW-11(b) Type 1		

Results Summary	
Governing condition	Internal pressure
Minimum thickness per UG-16	1,5 mm + 3 mm = 4,5 mm
Design thickness due to internal pressure (t)	7,2 mm
Maximum allowable working pressure (MAWP)	92,09 bar
Maximum allowable pressure (MAP)	121,95 bar
Rated MDMT	-48 °C

UCS-66 Material Toughness Requirements	
Governing thickness, t _g =	11,11 mm
Exemption temperature from Fig UCS-66M Curve B =	-24,98°C
$t_r = \frac{56,38 \cdot 109,54}{1.180 \cdot 0,85 + 0,4 \cdot 56,38} =$	6,02 mm
Stress ratio = $\frac{t_r \cdot E^*}{t_n - c} = \frac{6,02 \cdot 0,85}{12,7 - 3} =$	0,5277
Reduction in MDMT, T _R from Fig UCS-66.1M =	28,9°C
$MDMT = \max [MDMT - T_R, -48] = \max [-24,98 - 28,9, -48] =$	-48°C
Material is exempt from impact testing at the Design MDMT of 0°C.	

Design thickness, (at 135 °C) Appendix 1-1

$$t = \frac{P \cdot R_o}{S \cdot E + 0,40 \cdot P} + \text{Corrosion} = \frac{39 \cdot 109,54}{1.180 \cdot 0,85 + 0,40 \cdot 39} + 3 = \underline{7,2} \text{ mm}$$

Maximum allowable working pressure, (at 135 °C) Appendix 1-1

$$P = \frac{S \cdot E \cdot t}{R_o - 0,40 \cdot t} - P_s = \frac{1.180 \cdot 0,85 \cdot 9,7}{109,54 - 0,40 \cdot 9,7} - 0 = \underline{92,09} \text{ bar}$$

Maximum allowable pressure, (at 21,11 °C) Appendix 1-1

$$P = \frac{S \cdot E \cdot t}{R_o - 0,40 \cdot t} = \frac{1.180 \cdot 0,85 \cdot 12,7}{109,54 - 0,40 \cdot 12,7} = \underline{121,95} \text{ bar}$$

ASME Section VIII Division 1 UG-80(a) Out-of-Roundness
$(D_{\max} - D_{\min})$ shall not exceed 1% of D
When the cross section passes through an opening or within 1 I.D. of the opening, $(D_{\max} - D_{\min})$ shall not exceed 1% of $D + 2\%$ of the inside diameter of the opening

Air Inlet (N1)

ASME Section VIII Division 1, 2021 Edition Metric

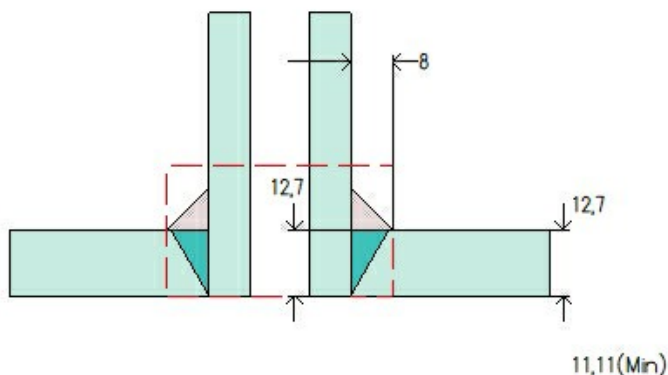

Note: round inside edges per UG-76(c)

Location and Orientation

Located on	B16.9 Pipe Cap - Left Side
Orientation	0°
End of nozzle to datum line	1.056 mm
Calculated as hillside	No
Distance to head center, R	0 mm
Passes through a Category A joint	No

Nozzle

Description	NPS 0,75 XXS DN 20
Access opening	No
Material specification	SA-106 B Smls Pipe (II-D Metric p. 16, In. 16)
Inside diameter, new	11,02 mm
Pipe nominal wall thickness	7,82 mm
Pipe minimum wall thickness ¹	6,85 mm
Corrosion allowance	3 mm
Projection available outside vessel, L _{pr}	64,44 mm
Local vessel minimum thickness	11,11 mm
Liquid static head included	0 bar

Welds

Inner fillet, Leg ₄₁	8 mm
Nozzle to vessel groove weld	12,7 mm

Radiography

Longitudinal seam	Seamless No RT
Circumferential seam	Full UW-11(a) Type 1

¹Pipe minimum thickness = nominal thickness times pipe tolerance factor of 0,875.

UCS-66 Material Toughness Requirements Nozzle

$t_r = \frac{56,38-8,51}{1.180 \cdot 1 - 0,6 \cdot 56,38} =$	0,42 mm
Stress ratio $= \frac{t_r \cdot E^*}{t_n - c} = \frac{0,42 \cdot 1}{6,85 - 3} =$	0,1089
Stress ratio $\leq 0,35$, MDMT per UCS-66(b)(3) =	-105°C
Material is exempt from impact testing at the Design MDMT of 0°C.	

Reinforcement Calculations for Internal Pressure

UG-37 Area Calculation Summary (cm ²)							UG-45 Summary (mm)	
For P = 39 bar @ 135 °C							The nozzle passes UG-45	
A required	A available	A ₁	A ₂	A ₃	A ₅	A welds	t _{req}	t _{min}
This nozzle is exempt from area calculations per UG-36(c)(3)(a)							5,51	6,85

UG-41 Weld Failure Path Analysis Summary
The nozzle is exempt from weld strength calculations per UW-15(b)(2)

UW-16 Weld Sizing Summary			
Weld description	Required weld throat size (mm)	Actual weld throat size (mm)	Status
Nozzle to shell fillet (Leg ₄₁)	3,38	5,6	weld size is adequate

Calculations for internal pressure 39 bar @ 135 °C

Parallel Limit of reinforcement per UG-40

$$\begin{aligned}
 L_R &= \max [d, R_n + (t_n - C_n) + (t - C)] \\
 &= \max [17,02, 8,51 + (7,82 - 3) + (11,11 - 3)] \\
 &= 21,45 \text{ mm}
 \end{aligned}$$

Outer Normal Limit of reinforcement per UG-40

$$\begin{aligned}
 L_H &= \min [2,5 \cdot (t - C), 2,5 \cdot (t_n - C_n) + t_e] \\
 &= \min [2,5 \cdot (11,11 - 3), 2,5 \cdot (7,82 - 3) + 0] \\
 &= 12,06 \text{ mm}
 \end{aligned}$$

Nozzle required thickness per UG-27(c)(1)

$$\begin{aligned}
 t_{rn} &= \frac{P \cdot R_n}{S_n \cdot E - 0,6 \cdot P} \\
 &= \frac{39,0001 \cdot 8,51}{1,180 \cdot 1 - 0,6 \cdot 39,0001} \\
 &= 0,29 \text{ mm}
 \end{aligned}$$

Required thickness t_r from UG-37(a)(c)

$$\begin{aligned}
 t_r &= \frac{P \cdot K_1 \cdot D_o}{2 \cdot S \cdot E + 0,8 \cdot P} \\
 &= \frac{39,0001 \cdot 0,8737 \cdot 219,07}{2 \cdot 1,180 \cdot 1 + 0,8 \cdot 39,0001} \\
 &= 3,12 \text{ mm}
 \end{aligned}$$

Required thickness t_r per Interpretation VIII-1-07-50

$$t_r = \frac{P \cdot D_o \cdot K}{2 \cdot S \cdot E + 2 \cdot P \cdot (K - 0,1)} = \frac{39 \cdot 219,07 \cdot 0,961673}{2 \cdot 1,180 \cdot 0,85 + 2 \cdot 39 \cdot (0,961673 - 0,1)} = 3,96 \text{ mm}$$

This opening does not require reinforcement per UG-36(c)(3)(a)

UW-16(c) Weld Check

Fillet weld: $t_{\min} = \min [19\text{mm}, t_n, t] = 4,82 \text{ mm}$

$$t_{c(\min)} = \min [6 \text{ mm}, 0,7 \cdot t_{\min}] = 3,38 \text{ mm}$$

$$t_{c(\text{actual})} = 0,7 \cdot \text{Leg} = 0,7 \cdot 8 = 5,6 \text{ mm}$$

The fillet weld size is satisfactory.

Weld strength calculations are not required for this detail which conforms to Fig. UW-16.1, sketch (c-e).

UG-45 Nozzle Neck Thickness Check

Interpretation VIII-1-83-66 has been applied.

$$\begin{aligned} t_{aUG-27} &= \frac{P \cdot R_n}{S_n \cdot E - 0,6 \cdot P} + \text{Corrosion} \\ &= \frac{39,0001 \cdot 8,51}{1.180 \cdot 1 - 0,6 \cdot 39,0001} + 3 \\ &= 3,29 \text{ mm} \end{aligned}$$

$$\begin{aligned} t_a &= \max [t_{aUG-27}, t_{aUG-22}] \\ &= \max [3,29, 0] \\ &= 3,29 \text{ mm} \end{aligned}$$

$$\begin{aligned} t_{b1} &= \frac{P \cdot D_o \cdot K}{2 \cdot S \cdot E + 2 \cdot P \cdot (K - 0,1)} + \text{Corrosion} \\ &= \frac{39 \cdot 219,07 \cdot 0,961673}{2 \cdot 1.180 \cdot 1 + 2 \cdot 39 \cdot (0,961673 - 0,1)} + 3 \\ &= 6,38 \text{ mm} \end{aligned}$$

$$\begin{aligned} t_{b1} &= \max [t_{b1}, t_{bUG16}] \\ &= \max [6,39, 4,5] \\ &= 6,39 \text{ mm} \end{aligned}$$

$$\begin{aligned} t_b &= \min [t_{b3}, t_{b1}] \\ &= \min [5,51, 6,39] \\ &= 5,51 \text{ mm} \end{aligned}$$

$$\begin{aligned} t_{UG-45} &= \max [t_a, t_b] \\ &= \max [3,29, 5,51] \\ &= 5,51 \text{ mm} \end{aligned}$$

Available nozzle wall thickness new, $t_n = 0,875 \cdot 7,82 = 6,85 \text{ mm}$

The nozzle neck thickness is adequate.

Reinforcement Calculations for MAWP

The vessel wall thickness governs the MAWP of this nozzle.

UG-37 Area Calculation Summary (cm ²)							UG-45 Summary (mm)	
For P = 103,54 bar @ 135 °C							The nozzle passes UG-45	
A required	A available	A ₁	A ₂	A ₃	A ₅	A welds	t _{req}	t _{min}
This nozzle is exempt from area calculations per UG-36(c)(3)(a)							5,51	6,85

UG-41 Weld Failure Path Analysis Summary
The nozzle is exempt from weld strength calculations per UW-15(b)(2)

UW-16 Weld Sizing Summary			
Weld description	Required weld throat size (mm)	Actual weld throat size (mm)	Status
Nozzle to shell fillet (Leg ₄₁)	3,38	5,6	weld size is adequate

Calculations for internal pressure 103,54 bar @ 135 °C

Parallel Limit of reinforcement per UG-40

$$\begin{aligned}
 L_R &= \max [d, R_n + (t_n - C_n) + (t - C)] \\
 &= \max [17,02, 8,51 + (7,82 - 3) + (11,11 - 3)] \\
 &= 21,45 \text{ mm}
 \end{aligned}$$

Outer Normal Limit of reinforcement per UG-40

$$\begin{aligned}
 L_H &= \min [2,5 \cdot (t - C), 2,5 \cdot (t_n - C_n) + t_e] \\
 &= \min [2,5 \cdot (11,11 - 3), 2,5 \cdot (7,82 - 3) + 0] \\
 &= 12,06 \text{ mm}
 \end{aligned}$$

Nozzle required thickness per UG-27(c)(1)

$$\begin{aligned}
 t_{rn} &= \frac{P \cdot R_n}{S_n \cdot E - 0,6 \cdot P} \\
 &= \frac{103,5405 \cdot 8,51}{1.180 \cdot 1 - 0,6 \cdot 103,5405} \\
 &= 0,79 \text{ mm}
 \end{aligned}$$

Required thickness t_r from UG-37(a)(c)

$$\begin{aligned}
 t_r &= \frac{P \cdot K_1 \cdot D_o}{2 \cdot S \cdot E + 0,8 \cdot P} \\
 &= \frac{103,5405 \cdot 0,8737 \cdot 219,07}{2 \cdot 1.180 \cdot 1 + 0,8 \cdot 103,5405} \\
 &= 8,11 \text{ mm}
 \end{aligned}$$

Required thickness t_r per Interpretation VIII-1-07-50

$$t_r = \frac{P \cdot D_o \cdot K}{2 \cdot S \cdot E + 2 \cdot P \cdot (K - 0,1)} = \frac{103,54 \cdot 219,07 \cdot 0,961673}{2 \cdot 1.180 \cdot 0,85 + 2 \cdot 103,54 \cdot (0,961673 - 0,1)} = 9,99 \text{ mm}$$

This opening does not require reinforcement per UG-36(c)(3)(a)

UW-16(c) Weld Check

Fillet weld: $t_{\min} = \min [19\text{mm}, t_n, t] = 4,82 \text{ mm}$

$t_{c(\min)} = \min [6 \text{ mm}, 0,7 \cdot t_{\min}] = 3,38 \text{ mm}$

$t_{c(\text{actual})} = 0,7 \cdot \text{Leg} = 0,7 \cdot 8 = 5,6 \text{ mm}$

The fillet weld size is satisfactory.

Weld strength calculations are not required for this detail which conforms to Fig. UW-16.1, sketch (c-e).

UG-45 Nozzle Neck Thickness Check

Interpretation VIII-1-83-66 has been applied.

$$\begin{aligned} t_{aUG-27} &= \frac{P \cdot R_n}{S_n \cdot E - 0,6 \cdot P} + \text{Corrosion} \\ &= \frac{103,5405 \cdot 8,51}{1,180 \cdot 1 - 0,6 \cdot 103,5405} + 3 \\ &= 3,79 \text{ mm} \end{aligned}$$

$$\begin{aligned} t_a &= \max [t_{aUG-27}, t_{aUG-22}] \\ &= \max [3,79, 0] \\ &= 3,79 \text{ mm} \end{aligned}$$

$$\begin{aligned} t_{b1} &= \frac{P \cdot D_o \cdot K}{2 \cdot S \cdot E + 2 \cdot P \cdot (K - 0,1)} + \text{Corrosion} \\ &= \frac{103,54 \cdot 219,07 \cdot 0,961673}{2 \cdot 1,180 \cdot 1 + 2 \cdot 103,54 \cdot (0,961673 - 0,1)} + 3 \\ &= 11,59 \text{ mm} \end{aligned}$$

$$\begin{aligned} t_{b1} &= \max [t_{b1}, t_{bUG16}] \\ &= \max [11,59, 4,5] \\ &= 11,59 \text{ mm} \end{aligned}$$

$$\begin{aligned} t_b &= \min [t_{b3}, t_{b1}] \\ &= \min [5,51, 11,59] \\ &= 5,51 \text{ mm} \end{aligned}$$

$$\begin{aligned} t_{UG-45} &= \max [t_a, t_b] \\ &= \max [3,79, 5,51] \\ &= 5,51 \text{ mm} \end{aligned}$$

Available nozzle wall thickness new, $t_n = 0,875 \cdot 7,82 = 6,85 \text{ mm}$

The nozzle neck thickness is adequate.

Reinforcement Calculations for MAP

The vessel wall thickness governs the MAP of this nozzle.

UG-37 Area Calculation Summary (cm ²)							UG-45 Summary (mm)	
For P = 139,29 bar @ 21,11 °C							The nozzle passes UG-45	
A required	A available	A ₁	A ₂	A ₃	A ₅	A welds	t _{req}	t _{min}
This nozzle is exempt from area calculations per UG-36(c)(3)(a)							2,51	6,85

UG-41 Weld Failure Path Analysis Summary
The nozzle is exempt from weld strength calculations per UW-15(b)(2)

Calculations for internal pressure 139,29 bar @ 21,11 °C

Parallel Limit of reinforcement per UG-40

$$\begin{aligned}
 L_R &= \max [d, R_n + (t_n - C_n) + (t - C)] \\
 &= \max [11,02, 5,51 + (7,82 - 0) + (11,11 - 0)] \\
 &= 24,45 \text{ mm}
 \end{aligned}$$

Outer Normal Limit of reinforcement per UG-40

$$\begin{aligned}
 L_H &= \min [2,5 \cdot (t - C), 2,5 \cdot (t_n - C_n) + t_e] \\
 &= \min [2,5 \cdot (11,11 - 0), 2,5 \cdot (7,82 - 0) + 0] \\
 &= 19,56 \text{ mm}
 \end{aligned}$$

Nozzle required thickness per UG-27(c)(1)

$$\begin{aligned}
 t_{rn} &= \frac{P \cdot R_n}{S_n \cdot E - 0,6 \cdot P} \\
 &= \frac{139,2932 \cdot 5,51}{1.180 \cdot 1 - 0,6 \cdot 139,2932} \\
 &= 0,7 \text{ mm}
 \end{aligned}$$

Required thickness t_r from UG-37(a)(c)

$$\begin{aligned}
 t_r &= \frac{P \cdot K_1 \cdot D_o}{2 \cdot S \cdot E + 0,8 \cdot P} \\
 &= \frac{139,2932 \cdot 0,9 \cdot 219,07}{2 \cdot 1.180 \cdot 1 + 0,8 \cdot 139,2932} \\
 &= 11,11 \text{ mm}
 \end{aligned}$$

Required thickness t_r per Interpretation VIII-1-07-50

$$t_r = \frac{P \cdot D_o \cdot K}{2 \cdot S \cdot E + 2 \cdot P \cdot (K - 0,1)} = \frac{139,29 \cdot 219,07 \cdot 1}{2 \cdot 1.180 \cdot 0,85 + 2 \cdot 139,29 \cdot (1 - 0,1)} = 13,52 \text{ mm}$$

This opening does not require reinforcement per UG-36(c)(3)(a)

UG-45 Nozzle Neck Thickness Check

Interpretation VIII-1-83-66 has been applied.

$$\begin{aligned}t_{aUG-27} &= \frac{P \cdot R_n}{S_n \cdot E - 0,6 \cdot P} + \text{Corrosion} \\ &= \frac{139,2932 \cdot 5,51}{1.180 \cdot 1 - 0,6 \cdot 139,2932} + 0 \\ &= 0,7 \text{ mm}\end{aligned}$$

$$\begin{aligned}t_a &= \max [t_{aUG-27}, t_{aUG-22}] \\ &= \max [0,7, 0] \\ &= 0,7 \text{ mm}\end{aligned}$$

$$\begin{aligned}t_{b1} &= \frac{P \cdot D_o \cdot K}{2 \cdot S \cdot E + 2 \cdot P \cdot (K - 0,1)} + \text{Corrosion} \\ &= \frac{139,29 \cdot 219,07 \cdot 1}{2 \cdot 1.180 \cdot 1 + 2 \cdot 139,29 \cdot (1 - 0,1)} + 0 \\ &= 11,69 \text{ mm}\end{aligned}$$

$$\begin{aligned}t_{b1} &= \max [t_{b1}, t_{bUG16}] \\ &= \max [11,69, 1,5] \\ &= 11,69 \text{ mm}\end{aligned}$$

$$\begin{aligned}t_b &= \min [t_{b3}, t_{b1}] \\ &= \min [2,51, 11,69] \\ &= 2,51 \text{ mm}\end{aligned}$$

$$\begin{aligned}t_{UG-45} &= \max [t_a, t_b] \\ &= \max [0,7, 2,51] \\ &= 2,51 \text{ mm}\end{aligned}$$

Available nozzle wall thickness new, $t_n = 0,875 \cdot 7,82 = 6,85 \text{ mm}$

The nozzle neck thickness is adequate.

B16.9 Elbow #1 (N1)

ASME Section VIII Division 1, 2021 Edition Metric				
Component		ASME B16.9 Elbow		
Type		Long Radius 90-deg		
Material		SA-234 WPB (II-D Metric p. 16, In. 18)		
Pipe NPS and Schedule		NPS 0,75 XXS DN 20		
Attached To		Air Inlet (N1)		
Impact Tested	Normalized	Fine Grain Practice	PWHT	Maximize MDMT/ No MAWP
No	No	No	No	No
		Design Pressure (bar)	Design Temperature (°C)	Design MDMT (°C)
Internal		39	135	0
Static Liquid Head				
Condition		P_s (bar)	H_s (mm)	SG
Test horizontal		0,03	288,1	1
Dimensions				
Outer Diameter		26,67 mm		
Nominal Thickness		7,82 mm		
Minimum Thickness¹		6,85 mm		
Center-to-End, A		38 mm		
Corrosion	Inner	3 mm		
	Outer	0 mm		
Weight and Capacity				
		Weight (kg)	Capacity (liters)	
New		0,22	0,01	
Corroded		0,16	0,01	
Radiography				
Longitudinal seam		Seamless No RT		
Left Circumferential seam		Full UW-11(a) Type 1		
Right Circumferential seam		Full UW-11(a) Type 1		

¹ minimum thickness = nominal thickness times pipe tolerance factor of 0,875.

ASME B16.5-2017 Flange	
Description	NPS 0,75 Class 600 WN A105
Bolt Material	SA-193 B7 Bolt <= 64 (II-D Metric p. 410, In. 32)
Blind included	No
Rated MDMT	-44,78°C
Liquid static head	0 bar
MAWP rating	91,1 bar @ 135°C
MAP rating	102,1 bar @ 21,11°C
Hydrotest rating	154 bar @ 21,11°C
PWHT performed	No
Produced to Fine Grain Practice and Supplied in Heat Treated Condition	No
Impact Tested	No
Circumferential joint radiography	Full UW-11(a) Type 1
Bore diameter, B (specified by purchaser)	11,02 mm
Gasket	
Type	ASME B16.20 Spiral-Wound
Description	Garlock FLEXSEAL RW 316L SS / Flexible Graphite
Factor, m	3
Seating Stress, y	703,07 kgf/cm ²
Thickness, T	3 mm
Inner Diameter	25,4 mm
Outer Diameter	39,6 mm
Notes	
Flange rated MDMT per UCS-66(b)(1)(b) = -44,78°C (Coincident ratio = 0,5522) Bolts rated MDMT per Fig UCS-66 note (c) = -48°C	

Results Summary	
Governing condition	UG-16
Minimum thickness per UG-16	1,5 mm + 3 mm = 4,5 mm
Design thickness due to internal pressure (t)	3.43 mm
Maximum allowable working pressure (MAWP)	401.45 bar
Maximum allowable pressure (MAP)	849.81 bar
Rated MDMT	-105 °C

UCS-66 Material Toughness Requirements	
$t_r = 13,34 \cdot \left(1 - \exp\left(-\frac{56,38}{1.180 \cdot 1} \right) \right) =$	0,62 mm
Stress ratio = $\frac{t_r \cdot E^*}{t_n - c} = \frac{0,62 \cdot 1}{6,85 - 3} =$	0,1618
Stress ratio $\leq 0,35$, MDMT per UCS-66(b)(3) =	-105°C
Material is exempt from impact testing at the Design MDMT of 0°C.	

Design thickness, (at 135 °C) Appendix 1-2

$$t = R_o \cdot \left(1 - \exp\left[-\frac{P}{S \cdot E} \right] \right) + \text{Corrosion} = 13,34 \cdot \left(1 - \exp\left[-\frac{39}{1.180 \cdot 1,00} \right] \right) + 3 = \text{3.43 mm}$$

Maximum allowable working pressure, (at 135 °C) Appendix 1-2

$$P = S \cdot E \cdot \ln\left(\frac{R_o}{R_o - t}\right) - P_s = 1.180 \cdot 1,00 \cdot \ln\left(\frac{13,34}{13,34 - (7,82 \cdot 0,875 - 3)}\right) - 0 = \underline{401,45} \text{ bar}$$

Maximum allowable pressure, (at 21,11 °C) Appendix 1-2

$$P = S \cdot E \cdot \ln\left(\frac{R_o}{R_o - t}\right) = 1.180 \cdot 1,00 \cdot \ln\left(\frac{13,34}{13,34 - (7,82 \cdot 0,875)}\right) = \underline{849,81} \text{ bar}$$

Cylinder #1

ASME Section VIII Division 1, 2021 Edition Metric				
Component		Cylinder		
Material		SA-106 B Smls Pipe (II-D Metric p. 16, ln. 16)		
Pipe NPS and Schedule		NPS 8 Sch 80 (XS) DN 200		
Impact Tested	Normalized	Fine Grain Practice	PWHT	Maximize MDMT/ No MAWP
No	No	No	No	No
		Design Pressure (bar)	Design Temperature (°C)	Design MDMT (°C)
Internal		39	135	0
Static Liquid Head				
Condition	P_s (bar)	H_s (mm)	SG	
Test horizontal	0,03	346,84	1	
Dimensions				
Outer Diameter		219,07 mm		
Length		890 mm		
Pipe Nominal Thickness		12,7 mm		
Pipe Minimum Thickness¹		11,11 mm		
Corrosion	Inner	3 mm		
	Outer	0 mm		
Weight and Capacity				
		Weight (kg)	Capacity (liters)	
New		56,84	26,22	
Corroded		44,05	27,87	
Radiography				
Longitudinal seam		Seamless No RT		
Left Circumferential seam		Spot UW-11(b) Type 1		
Right Circumferential seam		Spot UW-11(b) Type 1		

¹Pipe minimum thickness = nominal thickness times pipe tolerance factor of 0,875.

Results Summary	
Governing condition	Internal pressure
Minimum thickness per UG-16	1,5 mm + 3 mm = 4,5 mm
Design thickness due to internal pressure (t)	7,2 mm
Maximum allowable working pressure (MAWP)	76,56 bar
Maximum allowable pressure (MAP)	106,06 bar
Rated MDMT	-45,68 °C

UCS-66 Material Toughness Requirements	
Governing thickness, t _g =	11,11 mm
Exemption temperature from Fig UCS-66M Curve B =	-24,98°C
$t_r = \frac{56,38 \cdot 109,54}{1.180 \cdot 0,85 + 0,4 \cdot 56,38} =$	6,02 mm
$\text{Stress ratio} = \frac{t_r \cdot E^*}{t_n - c} = \frac{6,02 \cdot 0,85}{11,11 - 3} =$	0,6309
Reduction in MDMT, T _R from Fig UCS-66.1M =	20,7°C
$MDMT = \max [MDMT - T_R, -48] = \max [-24,98 - 20,7, -48] =$	-45,68°C
Material is exempt from impact testing at the Design MDMT of 0°C.	

Design thickness, (at 135 °C) Appendix 1-1

$$t = \frac{P \cdot R_o}{S \cdot E + 0,40 \cdot P} + \text{Corrosion} = \frac{39 \cdot 109,54}{1.180 \cdot 0,85 + 0,40 \cdot 39} + 3 = \underline{7,2} \text{ mm}$$

Maximum allowable working pressure, (at 135 °C) Appendix 1-1

$$P = \frac{S \cdot E \cdot t}{R_o - 0,40 \cdot t} - P_s = \frac{1.180 \cdot 0,85 \cdot (12,7 \cdot 0,875 - 3)}{109,54 - 0,40 \cdot (12,7 \cdot 0,875 - 3)} - 0 = \underline{76,56} \text{ bar}$$

Maximum allowable pressure, (at 21,11 °C) Appendix 1-1

$$P = \frac{S \cdot E \cdot t}{R_o - 0,40 \cdot t} = \frac{1.180 \cdot 0,85 \cdot (12,7 \cdot 0,875)}{109,54 - 0,40 \cdot (12,7 \cdot 0,875)} = \underline{106,06} \text{ bar}$$

Temperature Gauge Connection (N3)

ASME Section VIII Division 1, 2021 Edition Metric

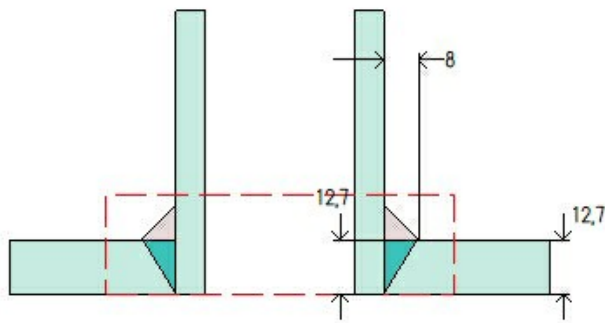

Note: round inside edges per UG-76(c)

Location and Orientation

Located on	Cylinder #1
Orientation	0°
Nozzle center line offset to datum line	770 mm
End of nozzle to shell center	250 mm
Passes through a Category A joint	No

Nozzle

Description	NPS 1,5 Sch 160 DN 40
Access opening	No
Material specification	SA-106 B Smls Pipe (II-D Metric p. 16, In. 16)
Inside diameter, new	33,99 mm
Pipe nominal wall thickness	7,14 mm
Pipe minimum wall thickness ¹	6,25 mm
Corrosion allowance	3 mm
Projection available outside vessel, L _{pr}	64,27 mm
Projection available outside vessel to flange face, L _f	140,47 mm
Local vessel minimum thickness	11,11 mm
Liquid static head included	0 bar

Welds

Inner fillet, Leg ₄₁	8 mm
Nozzle to vessel groove weld	12,7 mm

Radiography

Longitudinal seam	Seamless No RT
Circumferential seam	Full UW-11(a) Type 1

¹Pipe minimum thickness = nominal thickness times pipe tolerance factor of 0,875.

ASME B16.5-2017 Flange	
Description	NPS 1,5 Class 600 WN A105
Bolt Material	SA-193 B7 Bolt <= 64 (II-D Metric p. 410, In. 32)
Blind included	No
Rated MDMT	-44,78°C
Liquid static head	0 bar
MAWP rating	91,1 bar @ 135°C
MAP rating	102,1 bar @ 21,11°C
Hydrotest rating	154 bar @ 21,11°C
PWHT performed	No
Produced to Fine Grain Practice and Supplied in Heat Treated Condition	No
Impact Tested	No
Circumferential joint radiography	Full UW-11(a) Type 1
Bore diameter, B (specified by purchaser)	40,89 mm
Gasket	
Type	ASME B16.20 Spiral-Wound
Description	Garlock FLEXSEAL RW 316L SS / Flexible Graphite
Factor, m	3
Seating Stress, y	703,07 kgf/cm ²
Thickness, T	3 mm
Inner Diameter	54,1 mm
Outer Diameter	69,9 mm
Notes	
Flange rated MDMT per UCS-66(b)(1)(b) = -44,78°C (Coincident ratio = 0,5522) Bolts rated MDMT per Fig UCS-66 note (c) = -48°C	

UCS-66 Material Toughness Requirements Nozzle	
$t_r = \frac{56,38 \cdot 19,99}{1,180 \cdot 1 - 0,6 \cdot 56,38} =$	0,98 mm
Stress ratio = $\frac{t_r \cdot E^*}{t_n - c} = \frac{0,98 \cdot 1}{6,25 - 3} =$	0,303
Stress ratio ≤ 0,35, MDMT per UCS-66(b)(3) =	-105°C
Material is exempt from impact testing at the Design MDMT of 0°C.	

Reinforcement Calculations for Internal Pressure

UG-37 Area Calculation Summary (cm ²)							UG-45 Summary (mm)	
For P = 39 bar @ 135 °C							The nozzle passes UG-45	
A required	A available	A ₁	A ₂	A ₃	A ₅	A welds	t _{req}	t _{min}
This nozzle is exempt from area calculations per UG-36(c)(3)(a)							6,22	6,25

UG-41 Weld Failure Path Analysis Summary
The nozzle is exempt from weld strength calculations per UW-15(b)(2)

UW-16 Weld Sizing Summary			
Weld description	Required weld throat size (mm)	Actual weld throat size (mm)	Status
Nozzle to shell fillet (Leg ₄₁)	2,9	5,6	weld size is adequate

Calculations for internal pressure 39 bar @ 135 °C

Parallel Limit of reinforcement per UG-40

$$\begin{aligned}
 L_R &= \max [d, R_n + (t_n - C_n) + (t - C)] \\
 &= \max [39,99, 19,99 + (7,14 - 3) + (11,11 - 3)] \\
 &= 39,99 \text{ mm}
 \end{aligned}$$

Outer Normal Limit of reinforcement per UG-40

$$\begin{aligned}
 L_H &= \min [2,5 \cdot (t - C), 2,5 \cdot (t_n - C_n) + t_e] \\
 &= \min [2,5 \cdot (11,11 - 3), 2,5 \cdot (7,14 - 3) + 0] \\
 &= 10,34 \text{ mm}
 \end{aligned}$$

Nozzle required thickness per UG-27(c)(1)

$$\begin{aligned}
 t_{rn} &= \frac{P \cdot R_n}{S_n \cdot E - 0,6 \cdot P} \\
 &= \frac{39,0001 \cdot 19,99}{1,180 \cdot 1 - 0,6 \cdot 39,0001} \\
 &= 0,67 \text{ mm}
 \end{aligned}$$

Required thickness t_r from UG-37(a)

$$\begin{aligned}
 t_r &= \frac{P \cdot R_o}{S \cdot E + 0,4 \cdot P} \\
 &= \frac{39,0001 \cdot 109,54}{1,180 \cdot 1 + 0,4 \cdot 39,0001} \\
 &= 3,57 \text{ mm}
 \end{aligned}$$

Required thickness t_r per Interpretation VIII-1-07-50

$$\begin{aligned}
t_r &= \frac{P \cdot R_o}{S \cdot E + 0,4 \cdot P} \\
&= \frac{39,0001 \cdot 109,54}{1.180 \cdot 0,85 + 0,4 \cdot 39,0001} \\
&= 4,19 \text{ mm}
\end{aligned}$$

This opening does not require reinforcement per UG-36(c)(3)(a)

UW-16(c) Weld Check

Fillet weld: $t_{\min} = \min [19\text{mm}, t_n, t] = 4,14 \text{ mm}$

$$t_{c(\min)} = \min [6 \text{ mm}, 0,7 \cdot t_{\min}] = 2,9 \text{ mm}$$

$$t_{c(\text{actual})} = 0,7 \cdot \text{Leg} = 0,7 \cdot 8 = 5,6 \text{ mm}$$

The fillet weld size is satisfactory.

Weld strength calculations are not required for this detail which conforms to Fig. UW-16.1, sketch (c-e).

UG-45 Nozzle Neck Thickness Check

$$\begin{aligned}
t_{aUG-27} &= \frac{P \cdot R_n}{S_n \cdot E - 0,6 \cdot P} + \text{Corrosion} \\
&= \frac{39,0001 \cdot 19,99}{1.180 \cdot 1 - 0,6 \cdot 39,0001} + 3 \\
&= 3,67 \text{ mm}
\end{aligned}$$

$$\begin{aligned}
t_a &= \max [t_{aUG-27}, t_{aUG-22}] \\
&= \max [3,67, 0] \\
&= 3,67 \text{ mm}
\end{aligned}$$

$$\begin{aligned}
t_{b1} &= \frac{P \cdot R_o}{S \cdot E + 0,4 \cdot P} + \text{Corrosion} \\
&= \frac{39,0001 \cdot 109,54}{1.180 \cdot 1 + 0,4 \cdot 39,0001} + 3 \\
&= 6,57 \text{ mm}
\end{aligned}$$

$$\begin{aligned}
t_{b1} &= \max [t_{b1}, t_{bUG16}] \\
&= \max [6,57, 4,5] \\
&= 6,57 \text{ mm}
\end{aligned}$$

$$\begin{aligned}
t_b &= \min [t_{b3}, t_{b1}] \\
&= \min [6,22, 6,57] \\
&= 6,22 \text{ mm}
\end{aligned}$$

$$\begin{aligned}
t_{UG-45} &= \max [t_a, t_b] \\
&= \max [3,67, 6,22] \\
&= 6,22 \text{ mm}
\end{aligned}$$

Available nozzle wall thickness new, $t_n = 0,875 \cdot 7,14 = 6,25$ mm

The nozzle neck thickness is adequate.

Reinforcement Calculations for MAWP

The vessel wall thickness governs the MAWP of this nozzle.

UG-37 Area Calculation Summary (cm ²)						UG-45 Summary (mm)		
For P = 90,07 bar @ 135 °C						The nozzle passes UG-45		
A required	A available	A ₁	A ₂	A ₃	A ₅	A welds	t _{req}	t _{min}
This nozzle is exempt from area calculations per UG-36(c)(3)(a)						6,22	6,25	

UG-41 Weld Failure Path Analysis Summary
The nozzle is exempt from weld strength calculations per UW-15(b)(2)

UW-16 Weld Sizing Summary			
Weld description	Required weld throat size (mm)	Actual weld throat size (mm)	Status
Nozzle to shell fillet (Leg ₄₁)	2,9	5,6	weld size is adequate

Calculations for internal pressure 90,07 bar @ 135 °C

Parallel Limit of reinforcement per UG-40

$$\begin{aligned}
 L_R &= \max [d, R_n + (t_n - C_n) + (t - C)] \\
 &= \max [39,99, 19,99 + (7,14 - 3) + (11,11 - 3)] \\
 &= 39,99 \text{ mm}
 \end{aligned}$$

Outer Normal Limit of reinforcement per UG-40

$$\begin{aligned}
 L_H &= \min [2,5 \cdot (t - C), 2,5 \cdot (t_n - C_n) + t_e] \\
 &= \min [2,5 \cdot (11,11 - 3), 2,5 \cdot (7,14 - 3) + 0] \\
 &= 10,34 \text{ mm}
 \end{aligned}$$

Nozzle required thickness per UG-27(c)(1)

$$\begin{aligned}
 t_{rn} &= \frac{P \cdot R_n}{S_n \cdot E - 0,6 \cdot P} \\
 &= \frac{90,0666 \cdot 19,99}{1,180 \cdot 1 - 0,6 \cdot 90,0666} \\
 &= 1,6 \text{ mm}
 \end{aligned}$$

Required thickness t_r from UG-37(a)

$$\begin{aligned}
 t_r &= \frac{P \cdot R_o}{S \cdot E + 0,4 \cdot P} \\
 &= \frac{90,0666 \cdot 109,54}{1,180 \cdot 1 + 0,4 \cdot 90,0666} \\
 &= 8,11 \text{ mm}
 \end{aligned}$$

Required thickness t_r per Interpretation VIII-1-07-50

$$\begin{aligned}
t_r &= \frac{P \cdot R_o}{S \cdot E + 0,4 \cdot P} \\
&= \frac{90,0666 \cdot 109,54}{1.180 \cdot 0,85 + 0,4 \cdot 90,0666} \\
&= 9,49 \text{ mm}
\end{aligned}$$

This opening does not require reinforcement per UG-36(c)(3)(a)

UW-16(c) Weld Check

Fillet weld: $t_{\min} = \min [19\text{mm}, t_n, t] = 4,14 \text{ mm}$

$t_{c(\min)} = \min [6 \text{ mm}, 0,7 \cdot t_{\min}] = 2,9 \text{ mm}$

$t_{c(\text{actual})} = 0,7 \cdot \text{Leg} = 0,7 \cdot 8 = 5,6 \text{ mm}$

The fillet weld size is satisfactory.

Weld strength calculations are not required for this detail which conforms to Fig. UW-16.1, sketch (c-e).

UG-45 Nozzle Neck Thickness Check

$$\begin{aligned}
t_{aUG-27} &= \frac{P \cdot R_n}{S_n \cdot E - 0,6 \cdot P} + \text{Corrosion} \\
&= \frac{90,0666 \cdot 19,99}{1.180 \cdot 1 - 0,6 \cdot 90,0666} + 3 \\
&= 4,6 \text{ mm}
\end{aligned}$$

$$\begin{aligned}
t_a &= \max [t_{aUG-27}, t_{aUG-22}] \\
&= \max [4,6, 0] \\
&= 4,6 \text{ mm}
\end{aligned}$$

$$\begin{aligned}
t_{b1} &= \frac{P \cdot R_o}{S \cdot E + 0,4 \cdot P} + \text{Corrosion} \\
&= \frac{90,0666 \cdot 109,54}{1.180 \cdot 1 + 0,4 \cdot 90,0666} + 3 \\
&= 11,11 \text{ mm}
\end{aligned}$$

$$\begin{aligned}
t_{b1} &= \max [t_{b1}, t_{bUG16}] \\
&= \max [11,11, 4,5] \\
&= 11,11 \text{ mm}
\end{aligned}$$

$$\begin{aligned}
t_b &= \min [t_{b3}, t_{b1}] \\
&= \min [6,22, 11,11] \\
&= 6,22 \text{ mm}
\end{aligned}$$

$$\begin{aligned}
t_{UG-45} &= \max [t_a, t_b] \\
&= \max [4,6, 6,22] \\
&= 6,22 \text{ mm}
\end{aligned}$$

Available nozzle wall thickness new, $t_n = 0,875 \cdot 7,14 = 6,25$ mm

The nozzle neck thickness is adequate.

Reinforcement Calculations for MAP

The attached ASME B16.5 flange limits the nozzle MAP.

UG-37 Area Calculation Summary (cm ²)							UG-45 Summary (mm)	
For P = 102,1 bar @ 21,11 °C							The nozzle passes UG-45	
A required	A available	A ₁	A ₂	A ₃	A ₅	A welds	t _{req}	t _{min}
This nozzle is exempt from area calculations per UG-36(c)(3)(a)							3,22	6,25

UG-41 Weld Failure Path Analysis Summary
The nozzle is exempt from weld strength calculations per UW-15(b)(2)

Calculations for internal pressure 102,1 bar @ 21,11 °C

Parallel Limit of reinforcement per UG-40

$$\begin{aligned}
 L_R &= \max [d, R_n + (t_n - C_n) + (t - C)] \\
 &= \max [33,99, 16,99 + (7,14 - 0) + (11,11 - 0)] \\
 &= 35,24 \text{ mm}
 \end{aligned}$$

Outer Normal Limit of reinforcement per UG-40

$$\begin{aligned}
 L_H &= \min [2,5 \cdot (t - C), 2,5 \cdot (t_n - C_n) + t_e] \\
 &= \min [2,5 \cdot (11,11 - 0), 2,5 \cdot (7,14 - 0) + 0] \\
 &= 17,84 \text{ mm}
 \end{aligned}$$

Nozzle required thickness per UG-27(c)(1)

$$\begin{aligned}
 t_{rn} &= \frac{P \cdot R_n}{S_n \cdot E - 0,6 \cdot P} \\
 &= \frac{102,1 \cdot 16,99}{1.180 \cdot 1 - 0,6 \cdot 102,1} \\
 &= 1,55 \text{ mm}
 \end{aligned}$$

Required thickness t_r from UG-37(a)

$$\begin{aligned}
 t_r &= \frac{P \cdot R_o}{S \cdot E + 0,4 \cdot P} \\
 &= \frac{102,1 \cdot 109,54}{1.180 \cdot 1 + 0,4 \cdot 102,1} \\
 &= 9,16 \text{ mm}
 \end{aligned}$$

Required thickness t_r per Interpretation VIII-1-07-50

$$\begin{aligned}
 t_r &= \frac{P \cdot R_o}{S \cdot E + 0,4 \cdot P} \\
 &= \frac{102,1 \cdot 109,54}{1.180 \cdot 0,85 + 0,4 \cdot 102,1} \\
 &= 10,71 \text{ mm}
 \end{aligned}$$

This opening does not require reinforcement per UG-36(c)(3)(a)

UG-45 Nozzle Neck Thickness Check

$$\begin{aligned}t_{aUG-27} &= \frac{P \cdot R_n}{S_n \cdot E - 0,6 \cdot P} + \text{Corrosion} \\ &= \frac{102,1 \cdot 16,99}{1.180 \cdot 1 - 0,6 \cdot 102,1} + 0 \\ &= 1,55 \text{ mm}\end{aligned}$$

$$\begin{aligned}t_a &= \max [t_{aUG-27}, t_{aUG-22}] \\ &= \max [1,55, 0] \\ &= 1,55 \text{ mm}\end{aligned}$$

$$\begin{aligned}t_{b1} &= \frac{P \cdot R_o}{S \cdot E + 0,4 \cdot P} + \text{Corrosion} \\ &= \frac{102,1 \cdot 109,54}{1.180 \cdot 1 + 0,4 \cdot 102,1} + 0 \\ &= 9,16 \text{ mm}\end{aligned}$$

$$\begin{aligned}t_{b1} &= \max [t_{b1}, t_{bUG16}] \\ &= \max [9,16, 1,5] \\ &= 9,16 \text{ mm}\end{aligned}$$

$$\begin{aligned}t_b &= \min [t_{b3}, t_{b1}] \\ &= \min [3,22, 9,16] \\ &= 3,22 \text{ mm}\end{aligned}$$

$$\begin{aligned}t_{UG-45} &= \max [t_a, t_b] \\ &= \max [1,55, 3,22] \\ &= \underline{3,22} \text{ mm}\end{aligned}$$

Available nozzle wall thickness new, $t_n = 0,875 \cdot 7,14 = 6,25 \text{ mm}$

The nozzle neck thickness is adequate.

Temperature Transmitter Connection (N4)

ASME Section VIII Division 1, 2021 Edition Metric

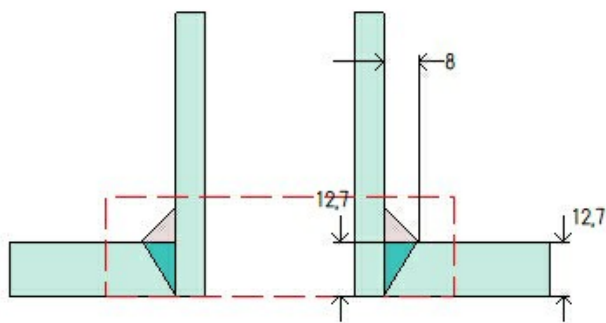

Note: round inside edges per UG-76(c)

Location and Orientation

Located on	Cylinder #1
Orientation	0°
Nozzle center line offset to datum line	555 mm
End of nozzle to shell center	250 mm
Passes through a Category A joint	No

Nozzle

Description	NPS 1,5 Sch 160 DN 40
Access opening	No
Material specification	SA-106 B Smls Pipe (II-D Metric p. 16, In. 16)
Inside diameter, new	33,99 mm
Pipe nominal wall thickness	7,14 mm
Pipe minimum wall thickness ¹	6,25 mm
Corrosion allowance	3 mm
Projection available outside vessel, L _{pr}	64,27 mm
Projection available outside vessel to flange face, L _f	140,47 mm
Local vessel minimum thickness	11,11 mm
Liquid static head included	0 bar

Welds

Inner fillet, Leg ₄₁	8 mm
Nozzle to vessel groove weld	12,7 mm

Radiography

Longitudinal seam	Seamless No RT
Circumferential seam	Full UW-11(a) Type 1

¹Pipe minimum thickness = nominal thickness times pipe tolerance factor of 0,875.

ASME B16.5-2017 Flange	
Description	NPS 1,5 Class 600 WN A105
Bolt Material	SA-193 B7 Bolt <= 64 (II-D Metric p. 410, In. 32)
Blind included	No
Rated MDMT	-44,78°C
Liquid static head	0 bar
MAWP rating	91,1 bar @ 135°C
MAP rating	102,1 bar @ 21,11°C
Hydrotest rating	154 bar @ 21,11°C
PWHT performed	No
Produced to Fine Grain Practice and Supplied in Heat Treated Condition	No
Impact Tested	No
Circumferential joint radiography	Full UW-11(a) Type 1
Bore diameter, B (specified by purchaser)	40,89 mm
Gasket	
Type	ASME B16.20 Spiral-Wound
Description	Garlock FLEXSEAL RW 316L SS / Flexible Graphite
Factor, m	3
Seating Stress, y	703,07 kgf/cm ²
Thickness, T	3 mm
Inner Diameter	54,1 mm
Outer Diameter	69,9 mm
Notes	
Flange rated MDMT per UCS-66(b)(1)(b) = -44,78°C (Coincident ratio = 0,5522) Bolts rated MDMT per Fig UCS-66 note (c) = -48°C	

UCS-66 Material Toughness Requirements Nozzle	
$t_r = \frac{56,38 \cdot 19,99}{1.180 \cdot 1 - 0,6 \cdot 56,38} =$	0,98 mm
Stress ratio = $\frac{t_r \cdot E^*}{t_n - c} = \frac{0,98 \cdot 1}{6,25 - 3} =$	0,303
Stress ratio ≤ 0,35, MDMT per UCS-66(b)(3) =	-105°C
Material is exempt from impact testing at the Design MDMT of 0°C.	

Reinforcement Calculations for Internal Pressure

UG-37 Area Calculation Summary (cm ²)							UG-45 Summary (mm)	
For P = 39 bar @ 135 °C							The nozzle passes UG-45	
A required	A available	A ₁	A ₂	A ₃	A ₅	A welds	t _{req}	t _{min}
This nozzle is exempt from area calculations per UG-36(c)(3)(a)							6,22	6,25

UG-41 Weld Failure Path Analysis Summary
The nozzle is exempt from weld strength calculations per UW-15(b)(2)

UW-16 Weld Sizing Summary			
Weld description	Required weld throat size (mm)	Actual weld throat size (mm)	Status
Nozzle to shell fillet (Leg ₄₁)	2,9	5,6	weld size is adequate

Calculations for internal pressure 39 bar @ 135 °C

Parallel Limit of reinforcement per UG-40

$$\begin{aligned}
 L_R &= \max [d, R_n + (t_n - C_n) + (t - C)] \\
 &= \max [39,99, 19,99 + (7,14 - 3) + (11,11 - 3)] \\
 &= 39,99 \text{ mm}
 \end{aligned}$$

Outer Normal Limit of reinforcement per UG-40

$$\begin{aligned}
 L_H &= \min [2,5 \cdot (t - C), 2,5 \cdot (t_n - C_n) + t_e] \\
 &= \min [2,5 \cdot (11,11 - 3), 2,5 \cdot (7,14 - 3) + 0] \\
 &= 10,34 \text{ mm}
 \end{aligned}$$

Nozzle required thickness per UG-27(c)(1)

$$\begin{aligned}
 t_{rn} &= \frac{P \cdot R_n}{S_n \cdot E - 0,6 \cdot P} \\
 &= \frac{39,0001 \cdot 19,99}{1,180 \cdot 1 - 0,6 \cdot 39,0001} \\
 &= 0,67 \text{ mm}
 \end{aligned}$$

Required thickness t_r from UG-37(a)

$$\begin{aligned}
 t_r &= \frac{P \cdot R_o}{S \cdot E + 0,4 \cdot P} \\
 &= \frac{39,0001 \cdot 109,54}{1,180 \cdot 1 + 0,4 \cdot 39,0001} \\
 &= 3,57 \text{ mm}
 \end{aligned}$$

Required thickness t_r per Interpretation VIII-1-07-50

$$\begin{aligned}
 t_r &= \frac{P \cdot R_o}{S \cdot E + 0,4 \cdot P} \\
 &= \frac{39,0001 \cdot 109,54}{1.180 \cdot 0,85 + 0,4 \cdot 39,0001} \\
 &= 4,19 \text{ mm}
 \end{aligned}$$

This opening does not require reinforcement per UG-36(c)(3)(a)

UW-16(c) Weld Check

Fillet weld: $t_{\min} = \min [19\text{mm}, t_n, t] = 4,14 \text{ mm}$

$$t_{c(\min)} = \min [6 \text{ mm}, 0,7 \cdot t_{\min}] = 2,9 \text{ mm}$$

$$t_{c(\text{actual})} = 0,7 \cdot \text{Leg} = 0,7 \cdot 8 = 5,6 \text{ mm}$$

The fillet weld size is satisfactory.

Weld strength calculations are not required for this detail which conforms to Fig. UW-16.1, sketch (c-e).

UG-45 Nozzle Neck Thickness Check

$$\begin{aligned}
 t_{aUG-27} &= \frac{P \cdot R_n}{S_n \cdot E - 0,6 \cdot P} + \text{Corrosion} \\
 &= \frac{39,0001 \cdot 19,99}{1.180 \cdot 1 - 0,6 \cdot 39,0001} + 3 \\
 &= 3,67 \text{ mm}
 \end{aligned}$$

$$\begin{aligned}
 t_a &= \max [t_{aUG-27}, t_{aUG-22}] \\
 &= \max [3,67, 0] \\
 &= 3,67 \text{ mm}
 \end{aligned}$$

$$\begin{aligned}
 t_{b1} &= \frac{P \cdot R_o}{S \cdot E + 0,4 \cdot P} + \text{Corrosion} \\
 &= \frac{39,0001 \cdot 109,54}{1.180 \cdot 1 + 0,4 \cdot 39,0001} + 3 \\
 &= 6,57 \text{ mm}
 \end{aligned}$$

$$\begin{aligned}
 t_{b1} &= \max [t_{b1}, t_{bUG16}] \\
 &= \max [6,57, 4,5] \\
 &= 6,57 \text{ mm}
 \end{aligned}$$

$$\begin{aligned}
 t_b &= \min [t_{b3}, t_{b1}] \\
 &= \min [6,22, 6,57] \\
 &= 6,22 \text{ mm}
 \end{aligned}$$

$$\begin{aligned}
 t_{UG-45} &= \max [t_a, t_b] \\
 &= \max [3,67, 6,22] \\
 &= 6,22 \text{ mm}
 \end{aligned}$$

Available nozzle wall thickness new, $t_n = 0,875 \cdot 7,14 = 6,25$ mm

The nozzle neck thickness is adequate.

Reinforcement Calculations for MAWP

The vessel wall thickness governs the MAWP of this nozzle.

UG-37 Area Calculation Summary (cm ²)						UG-45 Summary (mm)		
For P = 90,07 bar @ 135 °C						The nozzle passes UG-45		
A required	A available	A ₁	A ₂	A ₃	A ₅	A welds	t _{req}	t _{min}
This nozzle is exempt from area calculations per UG-36(c)(3)(a)							6,22	6,25

UG-41 Weld Failure Path Analysis Summary
The nozzle is exempt from weld strength calculations per UW-15(b)(2)

UW-16 Weld Sizing Summary			
Weld description	Required weld throat size (mm)	Actual weld throat size (mm)	Status
Nozzle to shell fillet (Leg ₄₁)	2,9	5,6	weld size is adequate

Calculations for internal pressure 90,07 bar @ 135 °C

Parallel Limit of reinforcement per UG-40

$$\begin{aligned}
 L_R &= \max [d, R_n + (t_n - C_n) + (t - C)] \\
 &= \max [39,99, 19,99 + (7,14 - 3) + (11,11 - 3)] \\
 &= 39,99 \text{ mm}
 \end{aligned}$$

Outer Normal Limit of reinforcement per UG-40

$$\begin{aligned}
 L_H &= \min [2,5 \cdot (t - C), 2,5 \cdot (t_n - C_n) + t_e] \\
 &= \min [2,5 \cdot (11,11 - 3), 2,5 \cdot (7,14 - 3) + 0] \\
 &= 10,34 \text{ mm}
 \end{aligned}$$

Nozzle required thickness per UG-27(c)(1)

$$\begin{aligned}
 t_{rn} &= \frac{P \cdot R_n}{S_n \cdot E - 0,6 \cdot P} \\
 &= \frac{90,0666 \cdot 19,99}{1,180 \cdot 1 - 0,6 \cdot 90,0666} \\
 &= 1,6 \text{ mm}
 \end{aligned}$$

Required thickness t_r from UG-37(a)

$$\begin{aligned}
 t_r &= \frac{P \cdot R_o}{S \cdot E + 0,4 \cdot P} \\
 &= \frac{90,0666 \cdot 109,54}{1,180 \cdot 1 + 0,4 \cdot 90,0666} \\
 &= 8,11 \text{ mm}
 \end{aligned}$$

Required thickness t_r per Interpretation VIII-1-07-50

$$\begin{aligned}
t_r &= \frac{P \cdot R_o}{S \cdot E + 0,4 \cdot P} \\
&= \frac{90,0666 \cdot 109,54}{1.180 \cdot 0,85 + 0,4 \cdot 90,0666} \\
&= 9,49 \text{ mm}
\end{aligned}$$

This opening does not require reinforcement per UG-36(c)(3)(a)

UW-16(c) Weld Check

Fillet weld: $t_{\min} = \min [19\text{mm}, t_n, t] = 4,14 \text{ mm}$

$t_{c(\min)} = \min [6 \text{ mm}, 0,7 \cdot t_{\min}] = 2,9 \text{ mm}$

$t_{c(\text{actual})} = 0,7 \cdot \text{Leg} = 0,7 \cdot 8 = 5,6 \text{ mm}$

The fillet weld size is satisfactory.

Weld strength calculations are not required for this detail which conforms to Fig. UW-16.1, sketch (c-e).

UG-45 Nozzle Neck Thickness Check

$$\begin{aligned}
t_{aUG-27} &= \frac{P \cdot R_n}{S_n \cdot E - 0,6 \cdot P} + \text{Corrosion} \\
&= \frac{90,0666 \cdot 19,99}{1.180 \cdot 1 - 0,6 \cdot 90,0666} + 3 \\
&= 4,6 \text{ mm}
\end{aligned}$$

$$\begin{aligned}
t_a &= \max [t_{aUG-27}, t_{aUG-22}] \\
&= \max [4,6, 0] \\
&= 4,6 \text{ mm}
\end{aligned}$$

$$\begin{aligned}
t_{b1} &= \frac{P \cdot R_o}{S \cdot E + 0,4 \cdot P} + \text{Corrosion} \\
&= \frac{90,0666 \cdot 109,54}{1.180 \cdot 1 + 0,4 \cdot 90,0666} + 3 \\
&= 11,11 \text{ mm}
\end{aligned}$$

$$\begin{aligned}
t_{b1} &= \max [t_{b1}, t_{bUG16}] \\
&= \max [11,11, 4,5] \\
&= 11,11 \text{ mm}
\end{aligned}$$

$$\begin{aligned}
t_b &= \min [t_{b3}, t_{b1}] \\
&= \min [6,22, 11,11] \\
&= 6,22 \text{ mm}
\end{aligned}$$

$$\begin{aligned}
t_{UG-45} &= \max [t_a, t_b] \\
&= \max [4,6, 6,22] \\
&= 6,22 \text{ mm}
\end{aligned}$$

Available nozzle wall thickness new, $t_n = 0,875 \cdot 7,14 = 6,25$ mm

The nozzle neck thickness is adequate.

Reinforcement Calculations for MAP

The attached ASME B16.5 flange limits the nozzle MAP.

UG-37 Area Calculation Summary (cm ²)							UG-45 Summary (mm)	
For P = 102,1 bar @ 21,11 °C							The nozzle passes UG-45	
A required	A available	A ₁	A ₂	A ₃	A ₅	A welds	t _{req}	t _{min}
This nozzle is exempt from area calculations per UG-36(c)(3)(a)							3,22	6,25

UG-41 Weld Failure Path Analysis Summary
The nozzle is exempt from weld strength calculations per UW-15(b)(2)

Calculations for internal pressure 102,1 bar @ 21,11 °C

Parallel Limit of reinforcement per UG-40

$$\begin{aligned}
 L_R &= \max [d, R_n + (t_n - C_n) + (t - C)] \\
 &= \max [33,99, 16,99 + (7,14 - 0) + (11,11 - 0)] \\
 &= 35,24 \text{ mm}
 \end{aligned}$$

Outer Normal Limit of reinforcement per UG-40

$$\begin{aligned}
 L_H &= \min [2,5 \cdot (t - C), 2,5 \cdot (t_n - C_n) + t_e] \\
 &= \min [2,5 \cdot (11,11 - 0), 2,5 \cdot (7,14 - 0) + 0] \\
 &= 17,84 \text{ mm}
 \end{aligned}$$

Nozzle required thickness per UG-27(c)(1)

$$\begin{aligned}
 t_{rn} &= \frac{P \cdot R_n}{S_n \cdot E - 0,6 \cdot P} \\
 &= \frac{102,1 \cdot 16,99}{1.180 \cdot 1 - 0,6 \cdot 102,1} \\
 &= 1,55 \text{ mm}
 \end{aligned}$$

Required thickness t_r from UG-37(a)

$$\begin{aligned}
 t_r &= \frac{P \cdot R_o}{S \cdot E + 0,4 \cdot P} \\
 &= \frac{102,1 \cdot 109,54}{1.180 \cdot 1 + 0,4 \cdot 102,1} \\
 &= 9,16 \text{ mm}
 \end{aligned}$$

Required thickness t_r per Interpretation VIII-1-07-50

$$\begin{aligned}
 t_r &= \frac{P \cdot R_o}{S \cdot E + 0,4 \cdot P} \\
 &= \frac{102,1 \cdot 109,54}{1.180 \cdot 0,85 + 0,4 \cdot 102,1} \\
 &= 10,71 \text{ mm}
 \end{aligned}$$

This opening does not require reinforcement per UG-36(c)(3)(a)

UG-45 Nozzle Neck Thickness Check

$$\begin{aligned}t_{aUG-27} &= \frac{P \cdot R_n}{S_n \cdot E - 0,6 \cdot P} + \text{Corrosion} \\&= \frac{102,1 \cdot 16,99}{1.180 \cdot 1 - 0,6 \cdot 102,1} + 0 \\&= 1,55 \text{ mm}\end{aligned}$$

$$\begin{aligned}t_a &= \max [t_{aUG-27}, t_{aUG-22}] \\&= \max [1,55, 0] \\&= 1,55 \text{ mm}\end{aligned}$$

$$\begin{aligned}t_{b1} &= \frac{P \cdot R_o}{S \cdot E + 0,4 \cdot P} + \text{Corrosion} \\&= \frac{102,1 \cdot 109,54}{1.180 \cdot 1 + 0,4 \cdot 102,1} + 0 \\&= 9,16 \text{ mm}\end{aligned}$$

$$\begin{aligned}t_{b1} &= \max [t_{b1}, t_{bUG16}] \\&= \max [9,16, 1,5] \\&= 9,16 \text{ mm}\end{aligned}$$

$$\begin{aligned}t_b &= \min [t_{b3}, t_{b1}] \\&= \min [3,22, 9,16] \\&= 3,22 \text{ mm}\end{aligned}$$

$$\begin{aligned}t_{UG-45} &= \max [t_a, t_b] \\&= \max [1,55, 3,22] \\&= \underline{3,22} \text{ mm}\end{aligned}$$

Available nozzle wall thickness new, $t_n = 0,875 \cdot 7,14 = 6,25 \text{ mm}$

The nozzle neck thickness is adequate.

PSV Connection (N5)

ASME Section VIII Division 1, 2021 Edition Metric

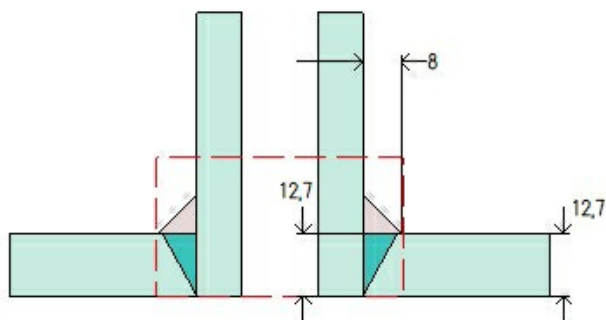

Note: round inside edges per UG-76(c)

Location and Orientation

Located on	Cylinder #1
Orientation	0°
Nozzle center line offset to datum line	328 mm
End of nozzle to shell center	250 mm
Passes through a Category A joint	No

Nozzle

Description	NPS 1 XXS DN 25
Access opening	No
Material specification	SA-106 B Smls Pipe (II-D Metric p. 16, In. 16)
Inside diameter, new	15,21 mm
Pipe nominal wall thickness	9,09 mm
Pipe minimum wall thickness ¹	7,96 mm
Corrosion allowance	3 mm
Projection available outside vessel, L _{pr}	72,14 mm
Projection available outside vessel to flange face, L _f	140,47 mm
Local vessel minimum thickness	11,11 mm
Liquid static head included	0 bar

Welds

Inner fillet, Leg ₄₁	8 mm
Nozzle to vessel groove weld	12,7 mm

Radiography

Longitudinal seam	Seamless No RT
Circumferential seam	Full UW-11(a) Type 1

¹Pipe minimum thickness = nominal thickness times pipe tolerance factor of 0,875.

ASME B16.5-2017 Flange	
Description	NPS 1 Class 600 WN A105
Bolt Material	SA-193 B7 Bolt <= 64 (II-D Metric p. 410, In. 32)
Blind included	No
Rated MDMT	-44,78°C
Liquid static head	0 bar
MAWP rating	91,1 bar @ 135°C
MAP rating	102,1 bar @ 21,11°C
Hydrotest rating	154 bar @ 21,11°C
PWHT performed	No
Produced to Fine Grain Practice and Supplied in Heat Treated Condition	No
Impact Tested	No
Circumferential joint radiography	Full UW-11(a) Type 1
Bore diameter, B (specified by purchaser)	26,67 mm
Gasket	
Type	ASME B16.20 Spiral-Wound
Description	Garlock FLEXSEAL RW 316L SS / Flexible Graphite
Factor, m	3
Seating Stress, y	703,07 kgf/cm ²
Thickness, T	3 mm
Inner Diameter	31,8 mm
Outer Diameter	47,8 mm
Notes	
Flange rated MDMT per UCS-66(b)(1)(b) = -44,78°C (Coincident ratio = 0,5522) Bolts rated MDMT per Fig UCS-66 note (c) = -48°C	

UCS-66 Material Toughness Requirements Nozzle	
$t_r = \frac{56,38 \cdot 10,61}{1.180 \cdot 1 - 0,6 \cdot 56,38} =$	0,52 mm
Stress ratio = $\frac{t_r \cdot E^*}{t_n - c} = \frac{0,52 \cdot 1}{7,96 - 3} =$	0,1053
Stress ratio ≤ 0,35, MDMT per UCS-66(b)(3) =	-105°C
Material is exempt from impact testing at the Design MDMT of 0°C.	

Reinforcement Calculations for Internal Pressure

UG-37 Area Calculation Summary (cm ²)							UG-45 Summary (mm)	
For P = 39 bar @ 135 °C							The nozzle passes UG-45	
A required	A available	A ₁	A ₂	A ₃	A ₅	A welds	t _{req}	t _{min}
This nozzle is exempt from area calculations per UG-36(c)(3)(a)							5,96	7,96

UG-41 Weld Failure Path Analysis Summary
The nozzle is exempt from weld strength calculations per UW-15(b)(2)

UW-16 Weld Sizing Summary			
Weld description	Required weld throat size (mm)	Actual weld throat size (mm)	Status
Nozzle to shell fillet (Leg ₄₁)	4,27	5,6	weld size is adequate

Calculations for internal pressure 39 bar @ 135 °C

Parallel Limit of reinforcement per UG-40

$$\begin{aligned}
 L_R &= \max [d, R_n + (t_n - C_n) + (t - C)] \\
 &= \max [21,21, 10,61 + (9,09 - 3) + (11,11 - 3)] \\
 &= 24,81 \text{ mm}
 \end{aligned}$$

Outer Normal Limit of reinforcement per UG-40

$$\begin{aligned}
 L_H &= \min [2,5 \cdot (t - C), 2,5 \cdot (t_n - C_n) + t_e] \\
 &= \min [2,5 \cdot (11,11 - 3), 2,5 \cdot (9,09 - 3) + 0] \\
 &= 15,23 \text{ mm}
 \end{aligned}$$

Nozzle required thickness per UG-27(c)(1)

$$\begin{aligned}
 t_{rn} &= \frac{P \cdot R_n}{S_n \cdot E - 0,6 \cdot P} \\
 &= \frac{39,0001 \cdot 10,61}{1,180 \cdot 1 - 0,6 \cdot 39,0001} \\
 &= 0,36 \text{ mm}
 \end{aligned}$$

Required thickness t_r from UG-37(a)

$$\begin{aligned}
 t_r &= \frac{P \cdot R_o}{S \cdot E + 0,4 \cdot P} \\
 &= \frac{39,0001 \cdot 109,54}{1,180 \cdot 1 + 0,4 \cdot 39,0001} \\
 &= 3,57 \text{ mm}
 \end{aligned}$$

Required thickness t_r per Interpretation VIII-1-07-50

$$\begin{aligned}
t_r &= \frac{P \cdot R_o}{S \cdot E + 0,4 \cdot P} \\
&= \frac{39,0001 \cdot 109,54}{1.180 \cdot 0,85 + 0,4 \cdot 39,0001} \\
&= 4,19 \text{ mm}
\end{aligned}$$

This opening does not require reinforcement per UG-36(c)(3)(a)

UW-16(c) Weld Check

Fillet weld: $t_{\min} = \min [19\text{mm}, t_n, t] = 6,09 \text{ mm}$

$$t_{c(\min)} = \min [6 \text{ mm}, 0,7 \cdot t_{\min}] = 4,27 \text{ mm}$$

$$t_{c(\text{actual})} = 0,7 \cdot \text{Leg} = 0,7 \cdot 8 = 5,6 \text{ mm}$$

The fillet weld size is satisfactory.

Weld strength calculations are not required for this detail which conforms to Fig. UW-16.1, sketch (c-e).

UG-45 Nozzle Neck Thickness Check

$$\begin{aligned}
t_{aUG-27} &= \frac{P \cdot R_n}{S_n \cdot E - 0,6 \cdot P} + \text{Corrosion} \\
&= \frac{39,0001 \cdot 10,61}{1.180 \cdot 1 - 0,6 \cdot 39,0001} + 3 \\
&= 3,36 \text{ mm}
\end{aligned}$$

$$\begin{aligned}
t_a &= \max [t_{aUG-27}, t_{aUG-22}] \\
&= \max [3,36, 0] \\
&= 3,36 \text{ mm}
\end{aligned}$$

$$\begin{aligned}
t_{b1} &= \frac{P \cdot R_o}{S \cdot E + 0,4 \cdot P} + \text{Corrosion} \\
&= \frac{39,0001 \cdot 109,54}{1.180 \cdot 1 + 0,4 \cdot 39,0001} + 3 \\
&= 6,57 \text{ mm}
\end{aligned}$$

$$\begin{aligned}
t_{b1} &= \max [t_{b1}, t_{bUG16}] \\
&= \max [6,57, 4,5] \\
&= 6,57 \text{ mm}
\end{aligned}$$

$$\begin{aligned}
t_b &= \min [t_{b3}, t_{b1}] \\
&= \min [5,96, 6,57] \\
&= 5,96 \text{ mm}
\end{aligned}$$

$$\begin{aligned}
t_{UG-45} &= \max [t_a, t_b] \\
&= \max [3,36, 5,96] \\
&= 5,96 \text{ mm}
\end{aligned}$$

Available nozzle wall thickness new, $t_n = 0,875 \cdot 9,09 = 7,96$ mm

The nozzle neck thickness is adequate.

Reinforcement Calculations for MAWP

The vessel wall thickness governs the MAWP of this nozzle.

UG-37 Area Calculation Summary (cm ²)						UG-45 Summary (mm)		
For P = 90,07 bar @ 135 °C						The nozzle passes UG-45		
A required	A available	A ₁	A ₂	A ₃	A ₅	A welds	t _{req}	t _{min}
This nozzle is exempt from area calculations per UG-36(c)(3)(a)						5,96	7,96	

UG-41 Weld Failure Path Analysis Summary
The nozzle is exempt from weld strength calculations per UW-15(b)(2)

UW-16 Weld Sizing Summary			
Weld description	Required weld throat size (mm)	Actual weld throat size (mm)	Status
Nozzle to shell fillet (Leg ₄₁)	4,27	5,6	weld size is adequate

Calculations for internal pressure 90,07 bar @ 135 °C

Parallel Limit of reinforcement per UG-40

$$\begin{aligned}
 L_R &= \max [d, R_n + (t_n - C_n) + (t - C)] \\
 &= \max [21,21, 10,61 + (9,09 - 3) + (11,11 - 3)] \\
 &= 24,81 \text{ mm}
 \end{aligned}$$

Outer Normal Limit of reinforcement per UG-40

$$\begin{aligned}
 L_H &= \min [2,5 \cdot (t - C), 2,5 \cdot (t_n - C_n) + t_e] \\
 &= \min [2,5 \cdot (11,11 - 3), 2,5 \cdot (9,09 - 3) + 0] \\
 &= 15,23 \text{ mm}
 \end{aligned}$$

Nozzle required thickness per UG-27(c)(1)

$$\begin{aligned}
 t_{rn} &= \frac{P \cdot R_n}{S_n \cdot E - 0,6 \cdot P} \\
 &= \frac{90,0666 \cdot 10,61}{1,180 \cdot 1 - 0,6 \cdot 90,0666} \\
 &= 0,85 \text{ mm}
 \end{aligned}$$

Required thickness t_r from UG-37(a)

$$\begin{aligned}
 t_r &= \frac{P \cdot R_o}{S \cdot E + 0,4 \cdot P} \\
 &= \frac{90,0666 \cdot 109,54}{1,180 \cdot 1 + 0,4 \cdot 90,0666} \\
 &= 8,11 \text{ mm}
 \end{aligned}$$

Required thickness t_r per Interpretation VIII-1-07-50

$$\begin{aligned}
t_r &= \frac{P \cdot R_o}{S \cdot E + 0,4 \cdot P} \\
&= \frac{90,0666 \cdot 109,54}{1.180 \cdot 0,85 + 0,4 \cdot 90,0666} \\
&= 9,49 \text{ mm}
\end{aligned}$$

This opening does not require reinforcement per UG-36(c)(3)(a)

UW-16(c) Weld Check

Fillet weld: $t_{\min} = \min [19\text{mm}, t_n, t] = 6,09 \text{ mm}$

$t_{c(\min)} = \min [6 \text{ mm}, 0,7 \cdot t_{\min}] = 4,27 \text{ mm}$

$t_{c(\text{actual})} = 0,7 \cdot \text{Leg} = 0,7 \cdot 8 = 5,6 \text{ mm}$

The fillet weld size is satisfactory.

Weld strength calculations are not required for this detail which conforms to Fig. UW-16.1, sketch (c-e).

UG-45 Nozzle Neck Thickness Check

$$\begin{aligned}
t_{aUG-27} &= \frac{P \cdot R_n}{S_n \cdot E - 0,6 \cdot P} + \text{Corrosion} \\
&= \frac{90,0666 \cdot 10,61}{1.180 \cdot 1 - 0,6 \cdot 90,0666} + 3 \\
&= 3,85 \text{ mm}
\end{aligned}$$

$$\begin{aligned}
t_a &= \max [t_{aUG-27}, t_{aUG-22}] \\
&= \max [3,85, 0] \\
&= 3,85 \text{ mm}
\end{aligned}$$

$$\begin{aligned}
t_{b1} &= \frac{P \cdot R_o}{S \cdot E + 0,4 \cdot P} + \text{Corrosion} \\
&= \frac{90,0666 \cdot 109,54}{1.180 \cdot 1 + 0,4 \cdot 90,0666} + 3 \\
&= 11,11 \text{ mm}
\end{aligned}$$

$$\begin{aligned}
t_{b1} &= \max [t_{b1}, t_{bUG16}] \\
&= \max [11,11, 4,5] \\
&= 11,11 \text{ mm}
\end{aligned}$$

$$\begin{aligned}
t_b &= \min [t_{b3}, t_{b1}] \\
&= \min [5,96, 11,11] \\
&= 5,96 \text{ mm}
\end{aligned}$$

$$\begin{aligned}
t_{UG-45} &= \max [t_a, t_b] \\
&= \max [3,85, 5,96] \\
&= 5,96 \text{ mm}
\end{aligned}$$

Available nozzle wall thickness new, $t_n = 0,875 \cdot 9,09 = 7,96$ mm

The nozzle neck thickness is adequate.

Reinforcement Calculations for MAP

The attached ASME B16.5 flange limits the nozzle MAP.

UG-37 Area Calculation Summary (cm ²)							UG-45 Summary (mm)	
For P = 102,1 bar @ 21,11 °C							The nozzle passes UG-45	
A required	A available	A ₁	A ₂	A ₃	A ₅	A welds	t _{req}	t _{min}
This nozzle is exempt from area calculations per UG-36(c)(3)(a)							2,96	7,96

UG-41 Weld Failure Path Analysis Summary
The nozzle is exempt from weld strength calculations per UW-15(b)(2)

Calculations for internal pressure 102,1 bar @ 21,11 °C

Parallel Limit of reinforcement per UG-40

$$\begin{aligned}
 L_R &= \max [d, R_n + (t_n - C_n) + (t - C)] \\
 &= \max [15,21, 7,61 + (9,09 - 0) + (11,11 - 0)] \\
 &= 27,81 \text{ mm}
 \end{aligned}$$

Outer Normal Limit of reinforcement per UG-40

$$\begin{aligned}
 L_H &= \min [2,5 \cdot (t - C), 2,5 \cdot (t_n - C_n) + t_e] \\
 &= \min [2,5 \cdot (11,11 - 0), 2,5 \cdot (9,09 - 0) + 0] \\
 &= 22,73 \text{ mm}
 \end{aligned}$$

Nozzle required thickness per UG-27(c)(1)

$$\begin{aligned}
 t_{rn} &= \frac{P \cdot R_n}{S_n \cdot E - 0,6 \cdot P} \\
 &= \frac{102,1 \cdot 7,61}{1.180 \cdot 1 - 0,6 \cdot 102,1} \\
 &= 0,69 \text{ mm}
 \end{aligned}$$

Required thickness t_r from UG-37(a)

$$\begin{aligned}
 t_r &= \frac{P \cdot R_o}{S \cdot E + 0,4 \cdot P} \\
 &= \frac{102,1 \cdot 109,54}{1.180 \cdot 1 + 0,4 \cdot 102,1} \\
 &= 9,16 \text{ mm}
 \end{aligned}$$

Required thickness t_r per Interpretation VIII-1-07-50

$$\begin{aligned}
 t_r &= \frac{P \cdot R_o}{S \cdot E + 0,4 \cdot P} \\
 &= \frac{102,1 \cdot 109,54}{1.180 \cdot 0,85 + 0,4 \cdot 102,1} \\
 &= 10,71 \text{ mm}
 \end{aligned}$$

This opening does not require reinforcement per UG-36(c)(3)(a)

UG-45 Nozzle Neck Thickness Check

$$\begin{aligned}t_{aUG-27} &= \frac{P \cdot R_n}{S_n \cdot E - 0,6 \cdot P} + \text{Corrosion} \\ &= \frac{102,1 \cdot 7,61}{1.180 \cdot 1 - 0,6 \cdot 102,1} + 0 \\ &= 0,69 \text{ mm}\end{aligned}$$

$$\begin{aligned}t_a &= \max [t_{aUG-27}, t_{aUG-22}] \\ &= \max [0,69, 0] \\ &= 0,69 \text{ mm}\end{aligned}$$

$$\begin{aligned}t_{b1} &= \frac{P \cdot R_o}{S \cdot E + 0,4 \cdot P} + \text{Corrosion} \\ &= \frac{102,1 \cdot 109,54}{1.180 \cdot 1 + 0,4 \cdot 102,1} + 0 \\ &= 9,16 \text{ mm}\end{aligned}$$

$$\begin{aligned}t_{b1} &= \max [t_{b1}, t_{bUG16}] \\ &= \max [9,16, 1,5] \\ &= 9,16 \text{ mm}\end{aligned}$$

$$\begin{aligned}t_b &= \min [t_{b3}, t_{b1}] \\ &= \min [2,96, 9,16] \\ &= 2,96 \text{ mm}\end{aligned}$$

$$\begin{aligned}t_{UG-45} &= \max [t_a, t_b] \\ &= \max [0,69, 2,96] \\ &= \underline{2,96} \text{ mm}\end{aligned}$$

Available nozzle wall thickness new, $t_n = 0,875 \cdot 9,09 = 7,96 \text{ mm}$

The nozzle neck thickness is adequate.

Drain (N6)

ASME Section VIII Division 1, 2021 Edition Metric

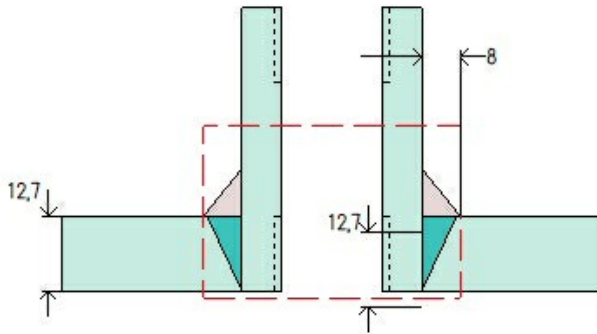

Note: round inside edges per UG-76(c)

Location and Orientation

Located on	Cylinder #1
Orientation	180°
Nozzle center line offset to datum line	470 mm
End of nozzle to shell center	142,69 mm
Passes through a Category A joint	No
Nozzle	
Description	NPS 0,5 Class 6000 DN 15 - Threaded Full Coupling
Access opening	No
Material specification	SA-105 (II-D Metric p. 20, ln. 31)
Inside diameter, new	21,34 mm
Nominal wall thickness	8,38 mm
Corrosion allowance	3 mm
Projection available outside vessel, L _{pr}	33,16 mm
Local vessel minimum thickness	11,11 mm
Liquid static head included	0 bar
Welds	
Inner fillet, Leg ₄₁	8 mm
Nozzle to vessel groove weld	12,7 mm
Radiography	
Longitudinal seam	Seamless No RT

UCS-66 Material Toughness Requirements Nozzle

$t_r = \frac{56,38 \cdot 13,67}{1,380 \cdot 1 - 0,6 \cdot 56,38} =$	0,57 mm
Stress ratio = $\frac{t_r \cdot E^*}{t_n - c} = \frac{0,57 \cdot 1}{8,38 - 3} =$	0,1064
Stress ratio $\leq 0,35$, MDMT per UCS-66(b)(3) =	-105°C
Material is exempt from impact testing at the Design MDMT of 0°C.	

Reinforcement Calculations for Internal Pressure

UG-37 Area Calculation Summary (cm ²)							UG-44 Summary (mm)	
For P = 39 bar @ 135 °C							The nozzle passes UG-44	
A required	A available	A ₁	A ₂	A ₃	A ₅	A welds	t _{req}	t _{min}
This nozzle is exempt from area calculations per UG-36(c)(3)(a)							4,5	8,38

UG-41 Weld Failure Path Analysis Summary
The nozzle is exempt from weld strength calculations per UW-15(b)(2)

UW-16 Weld Sizing Summary			
Weld description	Required weld throat size (mm)	Actual weld throat size (mm)	Status
Nozzle to shell fillet (Leg ₄₁)	2,5	5,6	weld size is adequate

Calculations for internal pressure 39 bar @ 135 °C

Parallel Limit of reinforcement per UG-40

$$\begin{aligned}
 L_R &= \max [d, R_n + (t_n - C_n) + (t - C)] \\
 &= \max [27,34, 13,67 + (8,38 - 3) + (11,11 - 3)] \\
 &= 27,34 \text{ mm}
 \end{aligned}$$

Outer Normal Limit of reinforcement per UG-40

$$\begin{aligned}
 L_H &= \min [2,5 \cdot (t - C), 2,5 \cdot (t_n - C_n) + t_e] \\
 &= \min [2,5 \cdot (11,11 - 3), 2,5 \cdot (8,38 - 3) + 0] \\
 &= 13,46 \text{ mm}
 \end{aligned}$$

Nozzle required thickness per UG-27(c)(1)

$$\begin{aligned}
 t_{rn} &= \frac{P \cdot R_n}{S_n \cdot E - 0,6 \cdot P} \\
 &= \frac{39,0001 \cdot 13,67}{1,380 \cdot 1 - 0,6 \cdot 39,0001} \\
 &= 0,39 \text{ mm}
 \end{aligned}$$

Required thickness t_r from UG-37(a)

$$\begin{aligned}
 t_r &= \frac{P \cdot R_o}{S \cdot E + 0,4 \cdot P} \\
 &= \frac{39,0001 \cdot 109,54}{1,180 \cdot 1 + 0,4 \cdot 39,0001} \\
 &= 3,57 \text{ mm}
 \end{aligned}$$

Required thickness t_r per Interpretation VIII-1-07-50

$$\begin{aligned}
t_r &= \frac{P \cdot R_o}{S \cdot E + 0,4 \cdot P} \\
&= \frac{39,0001 \cdot 109,54}{1.180 \cdot 0,85 + 0,4 \cdot 39,0001} \\
&= 4,19 \text{ mm}
\end{aligned}$$

This opening does not require reinforcement per UG-36(c)(3)(a)

UW-16(f)(2)(b) Weld Check

Fillet weld: $t_{\min} = \min [19\text{mm}, t_n, t] = 5,38 \text{ mm}$

$$t_{c(\min)} = \min [2,5 \text{ mm}, 0,7 \cdot t_{\min}] = 2,5 \text{ mm}$$

$$t_{c(\text{actual})} = 0,7 \cdot \text{Leg} = 0,7 \cdot 8 = 5,6 \text{ mm}$$

The fillet weld size is satisfactory.

Weld strength calculations are not required for this detail which conforms to Fig. UW-16.1, sketch (c-e).

UG-44 Thickness Check - ASME B16.11 Coupling

$$\begin{aligned}
t_{a\text{App } 1-1} &= \frac{P \cdot R_o}{S_n \cdot E + 0,4 \cdot P} + \text{Corrosion} \\
&= \frac{39,0001 \cdot 19,05}{1.380 \cdot 1 + 0,4 \cdot 39,0001} + 3 \\
&= 3,53 \text{ mm}
\end{aligned}$$

$$\begin{aligned}
t_{a\text{UG-44}} &= \max [t_{a\text{App } 1-1}, t_{b\text{UG16}}] \\
&= \max [3,53, 4,5] \\
&= 4,5 \text{ mm}
\end{aligned}$$

Available nozzle wall thickness new, $t_n = 8,38 \text{ mm}$

The nozzle neck thickness is adequate.

Reinforcement Calculations for MAWP

The vessel wall thickness governs the MAWP of this nozzle.

UG-37 Area Calculation Summary (cm ²)						UG-44 Summary (mm)		
For P = 90,07 bar @ 135 °C						The nozzle passes UG-44		
A required	A available	A ₁	A ₂	A ₃	A ₅	A welds	t _{req}	t _{min}
This nozzle is exempt from area calculations per UG-36(c)(3)(a)						4,5	8,38	

UG-41 Weld Failure Path Analysis Summary
The nozzle is exempt from weld strength calculations per UW-15(b)(2)

UW-16 Weld Sizing Summary			
Weld description	Required weld throat size (mm)	Actual weld throat size (mm)	Status
Nozzle to shell fillet (Leg ₄₁)	2,5	5,6	weld size is adequate

Calculations for internal pressure 90,07 bar @ 135 °C

Parallel Limit of reinforcement per UG-40

$$\begin{aligned}
 L_R &= \max [d, R_n + (t_n - C_n) + (t - C)] \\
 &= \max [27,34, 13,67 + (8,38 - 3) + (11,11 - 3)] \\
 &= 27,34 \text{ mm}
 \end{aligned}$$

Outer Normal Limit of reinforcement per UG-40

$$\begin{aligned}
 L_H &= \min [2,5 \cdot (t - C), 2,5 \cdot (t_n - C_n) + t_e] \\
 &= \min [2,5 \cdot (11,11 - 3), 2,5 \cdot (8,38 - 3) + 0] \\
 &= 13,46 \text{ mm}
 \end{aligned}$$

Nozzle required thickness per UG-27(c)(1)

$$\begin{aligned}
 t_{rn} &= \frac{P \cdot R_n}{S_n \cdot E - 0,6 \cdot P} \\
 &= \frac{90,0666 \cdot 13,67}{1,380 \cdot 1 - 0,6 \cdot 90,0666} \\
 &= 0,93 \text{ mm}
 \end{aligned}$$

Required thickness t_r from UG-37(a)

$$\begin{aligned}
 t_r &= \frac{P \cdot R_o}{S \cdot E + 0,4 \cdot P} \\
 &= \frac{90,0666 \cdot 109,54}{1,180 \cdot 1 + 0,4 \cdot 90,0666} \\
 &= 8,11 \text{ mm}
 \end{aligned}$$

Required thickness t_r per Interpretation VIII-1-07-50

$$\begin{aligned}
t_r &= \frac{P \cdot R_o}{S \cdot E + 0,4 \cdot P} \\
&= \frac{90,0666 \cdot 109,54}{1.180 \cdot 0,85 + 0,4 \cdot 90,0666} \\
&= 9,49 \text{ mm}
\end{aligned}$$

This opening does not require reinforcement per UG-36(c)(3)(a)

UW-16(f)(2)(b) Weld Check

Fillet weld: $t_{\min} = \min [19\text{mm}, t_n, t] = 5,38 \text{ mm}$

$t_{c(\min)} = \min [2,5 \text{ mm}, 0,7 \cdot t_{\min}] = 2,5 \text{ mm}$

$t_{c(\text{actual})} = 0,7 \cdot \text{Leg} = 0,7 \cdot 8 = 5,6 \text{ mm}$

The fillet weld size is satisfactory.

Weld strength calculations are not required for this detail which conforms to Fig. UW-16.1, sketch (c-e).

UG-44 Thickness Check - ASME B16.11 Coupling

$$\begin{aligned}
t_{a\text{App } 1-1} &= \frac{P \cdot R_o}{S_n \cdot E + 0,4 \cdot P} + \text{Corrosion} \\
&= \frac{90,0666 \cdot 19,05}{1.380 \cdot 1 + 0,4 \cdot 90,0666} + 3 \\
&= 4,21 \text{ mm}
\end{aligned}$$

$$\begin{aligned}
t_{a\text{UG-44}} &= \max [t_{a\text{App } 1-1}, t_{\text{UG16}}] \\
&= \max [4,21, 4,5] \\
&= 4,5 \text{ mm}
\end{aligned}$$

Available nozzle wall thickness new, $t_n = 8,38 \text{ mm}$

The nozzle neck thickness is adequate.

Reinforcement Calculations for MAP

The vessel wall thickness governs the MAP of this nozzle.

UG-37 Area Calculation Summary (cm ²)							UG-44 Summary (mm)	
For P = 124,78 bar @ 21,11 °C							The nozzle passes UG-44	
A required	A available	A ₁	A ₂	A ₃	A ₅	A welds	t _{req}	t _{min}
This nozzle is exempt from area calculations per UG-36(c)(3)(a)							1,66	8,38

UG-41 Weld Failure Path Analysis Summary
The nozzle is exempt from weld strength calculations per UW-15(b)(2)

Calculations for internal pressure 124,78 bar @ 21,11 °C

Parallel Limit of reinforcement per UG-40

$$\begin{aligned}
 L_R &= \max [d, R_n + (t_n - C_n) + (t - C)] \\
 &= \max [21,34, 10,67 + (8,38 - 0) + (11,11 - 0)] \\
 &= 30,16 \text{ mm}
 \end{aligned}$$

Outer Normal Limit of reinforcement per UG-40

$$\begin{aligned}
 L_H &= \min [2,5 \cdot (t - C), 2,5 \cdot (t_n - C_n) + t_e] \\
 &= \min [2,5 \cdot (11,11 - 0), 2,5 \cdot (8,38 - 0) + 0] \\
 &= 20,96 \text{ mm}
 \end{aligned}$$

Nozzle required thickness per UG-27(c)(1)

$$\begin{aligned}
 t_{rn} &= \frac{P \cdot R_n}{S_n \cdot E - 0,6 \cdot P} \\
 &= \frac{124,7779 \cdot 10,67}{1,380 \cdot 1 - 0,6 \cdot 124,7779} \\
 &= 1,02 \text{ mm}
 \end{aligned}$$

Required thickness t_r from UG-37(a)

$$\begin{aligned}
 t_r &= \frac{P \cdot R_o}{S \cdot E + 0,4 \cdot P} \\
 &= \frac{124,7779 \cdot 109,54}{1,180 \cdot 1 + 0,4 \cdot 124,7779} \\
 &= 11,11 \text{ mm}
 \end{aligned}$$

Required thickness t_r per Interpretation VIII-1-07-50

$$\begin{aligned}
 t_r &= \frac{P \cdot R_o}{S \cdot E + 0,4 \cdot P} \\
 &= \frac{124,7779 \cdot 109,54}{1,180 \cdot 0,85 + 0,4 \cdot 124,7779} \\
 &= 12,98 \text{ mm}
 \end{aligned}$$

This opening does not require reinforcement per UG-36(c)(3)(a)

UG-44 Thickness Check - ASME B16.11 Coupling

$$\begin{aligned}t_{aApp\ 1-1} &= \frac{P \cdot R_o}{S_n \cdot E + 0,4 \cdot P} + \text{Corrosion} \\ &= \frac{124,7779 \cdot 19,05}{1,380 \cdot 1 + 0,4 \cdot 124,7779} + 0 \\ &= 1,66 \text{ mm}\end{aligned}$$

$$\begin{aligned}t_{aUG-44} &= \max [t_{aApp\ 1-1}, t_{bUG16}] \\ &= \max [1,66, 1,5] \\ &= \underline{1,66} \text{ mm}\end{aligned}$$

Available nozzle wall thickness new, $t_n = 8,38$ mm

The nozzle neck thickness is adequate.

Straight Flange on B16.9 Pipe Cap - Right Side

ASME Section VIII Division 1, 2021 Edition Metric				
Component		Cylinder		
Material		SA-234 WPB (II-D Metric p. 16, ln. 18)		
Impact Tested	Normalized	Fine Grain Practice	PWHT	Maximize MDMT/ No MAWP
No	No	No	No	No
		Design Pressure (bar)	Design Temperature (°C)	Design MDMT (°C)
Internal		39	135	0
Static Liquid Head				
Condition		P_s (bar)	H_s (mm)	SG
Test horizontal		0,03	346,84	1
Dimensions				
Outer Diameter		219,07 mm		
Length		42,47 mm		
Nominal Thickness		12,7 mm		
Corrosion	Inner	3 mm		
	Outer	0 mm		
Weight and Capacity				
		Weight (kg)	Capacity (liters)	
New		2,74	1,25	
Corroded		2,12	1,33	
Radiography				
Longitudinal seam		Seamless No RT		
Left Circumferential seam		Spot UW-11(b) Type 1		

Results Summary	
Governing condition	Internal pressure
Minimum thickness per UG-16	1,5 mm + 3 mm = 4,5 mm
Design thickness due to internal pressure (t)	7,2 mm
Maximum allowable working pressure (MAWP)	92,09 bar
Maximum allowable pressure (MAP)	121,95 bar
Rated MDMT	-48 °C

UCS-66 Material Toughness Requirements	
Governing thickness, t _g =	11,11 mm
Exemption temperature from Fig UCS-66M Curve B =	-24,98°C
$t_r = \frac{56,38 \cdot 109,54}{1,180 \cdot 0,85 + 0,4 \cdot 56,38} =$	6,02 mm
Stress ratio = $\frac{t_r \cdot E^*}{t_n - c} = \frac{6,02 \cdot 0,85}{12,7 - 3} =$	0,5277
Reduction in MDMT, T _R from Fig UCS-66.1M =	28,9°C
$MDMT = \max [MDMT - T_R, -48] = \max [-24,98 - 28,9, -48] =$	-48°C
Material is exempt from impact testing at the Design MDMT of 0°C.	

Design thickness, (at 135 °C) Appendix 1-1

$$t = \frac{P \cdot R_o}{S \cdot E + 0,40 \cdot P} + \text{Corrosion} = \frac{39 \cdot 109,54}{1.180 \cdot 0,85 + 0,40 \cdot 39} + 3 = \underline{7,2} \text{ mm}$$

Maximum allowable working pressure, (at 135 °C) Appendix 1-1

$$P = \frac{S \cdot E \cdot t}{R_o - 0,40 \cdot t} - P_s = \frac{1.180 \cdot 0,85 \cdot 9,7}{109,54 - 0,40 \cdot 9,7} - 0 = \underline{92,09} \text{ bar}$$

Maximum allowable pressure, (at 21,11 °C) Appendix 1-1

$$P = \frac{S \cdot E \cdot t}{R_o - 0,40 \cdot t} = \frac{1.180 \cdot 0,85 \cdot 12,7}{109,54 - 0,40 \cdot 12,7} = \underline{121,95} \text{ bar}$$

ASME Section VIII Division 1 UG-80(a) Out-of-Roundness
$(D_{\max} - D_{\min})$ shall not exceed 1% of D
When the cross section passes through an opening or within 1 I.D. of the opening, $(D_{\max} - D_{\min})$ shall not exceed 1% of $D + 2\%$ of the inside diameter of the opening

B16.9 Pipe Cap - Right Side

ASME Section VIII Division 1, 2021 Edition Metric				
Component		ASME B16.9 Pipe Cap (modified)		
Material		SA-234 WPB (II-D Metric p. 16, In. 18)		
Attached To		Cylinder #1		
Impact Tested	Normalized	Fine Grain Practice	PWHT	Maximize MDMT/ No MAWP
No	No	No	No	No
		Design Pressure (bar)	Design Temperature (°C)	Design MDMT (°C)
Internal		39	135	0
Static Liquid Head				
Condition		P_s (bar)	H_s (mm)	SG
Test horizontal		0,03	346,84	1
Dimensions				
NPS and Schedule		NPS 8 Sch 80 (XS) DN 200		
Outer Diameter		219,07 mm		
Overall Length E		102 mm		
Nominal Thickness		12,7 mm		
Minimum Thickness¹		11,11 mm		
Corrosion	Inner	3 mm		
	Outer	0 mm		
Length L_{sf}		42,47 mm		
Nominal Thickness t_{sf}		12,7 mm		
Weight and Capacity				
		Weight (kg)²		Capacity (liters)²
New		7,72		2,2
Corroded		6,06		2,4
Radiography				
Category A joints		Seamless No RT		
Head to shell seam		Spot UW-11(b) Type 1		

¹ minimum thickness = nominal thickness times pipe tolerance factor of 0,875.

² includes straight flange

Results Summary	
Governing condition	internal pressure
Minimum thickness per UG-16	1,5 mm + 3 mm = 4,5 mm
Design thickness due to internal pressure (t)	<u>6,96</u> mm
Governing straight flange design thickness	7,2 mm
Maximum allowable working pressure (MAWP)	<u>82,74</u> bar
Maximum allowable pressure (MAP)	<u>111,98</u> bar
<u>Straight Flange</u> governs MDMT	-48°C

Factor K		
	$K = \left(\frac{1}{6}\right) \cdot \left[2 + \left(\frac{D}{2 \cdot h}\right)^2\right]$	
Corroded	$K = \left(\frac{1}{6}\right) \cdot \left[2 + \left(\frac{199,67}{2 \cdot 51,42}\right)^2\right]$	0,9617
New	$K = \left(\frac{1}{6}\right) \cdot \left[2 + \left(\frac{193,67}{2 \cdot 48,42}\right)^2\right]$	1

Design thickness for internal pressure, (Corroded at 135 °C) Appendix 1-4(c)

$$t = \frac{P \cdot D_o \cdot K}{2 \cdot S \cdot E + 2 \cdot P \cdot (K - 0,1)} + \text{Corrosion} = \frac{39 \cdot 219,07 \cdot 0,961673}{2 \cdot 1.180 \cdot 0,85 + 2 \cdot 39 \cdot (0,961673 - 0,1)} + 3 = 6.96 \text{ mm}$$

Maximum allowable working pressure, (Corroded at 135 °C) Appendix 1-4(c)

$$P = \frac{2 \cdot S \cdot E \cdot t}{K \cdot D_o - 2 \cdot t \cdot (K - 0,1)} - P_s = \frac{2 \cdot 1.180 \cdot 0,85 \cdot (0,875 \cdot 12,7 - 3)}{0,961673 \cdot 219,07 - 2 \cdot (0,875 \cdot 12,7 - 3) \cdot (0,961673 - 0,1)} - 0 = 82.74 \text{ bar}$$

Maximum allowable pressure, (New at 21,11 °C) Appendix 1-4(c)

$$P = \frac{2 \cdot S \cdot E \cdot t}{K \cdot D_o - 2 \cdot t \cdot (K - 0,1)} - P_s = \frac{2 \cdot 1.180 \cdot 0,85 \cdot 0,875 \cdot 12,7}{1 \cdot 219,07 - 2 \cdot 0,875 \cdot 12,7 \cdot (1 - 0,1)} - 0 = 111.98 \text{ bar}$$

ASME Section VIII Division 1 UG-81(a) Out-of-Roundness
Inside surface shall not deviate outside the shape by more than 1,25 % of D
Inside surface shall not deviate inside the shape by more than 0,625 % of D

Air Outlet (N2)

ASME Section VIII Division 1, 2021 Edition Metric

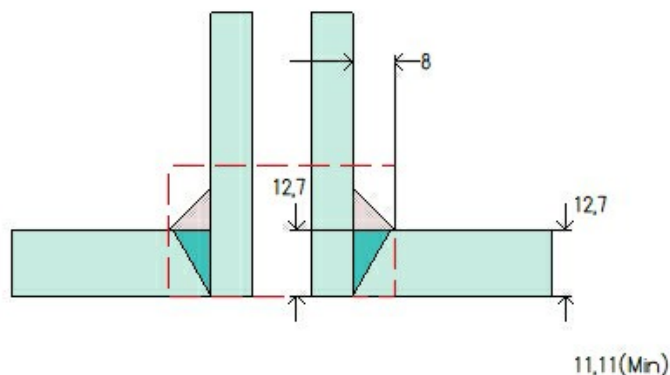

Note: round inside edges per UG-76(c)

Location and Orientation

Located on	B16.9 Pipe Cap - Right Side
Orientation	0°
End of nozzle to datum line	-166 mm
Calculated as hillside	No
Distance to head center, R	0 mm
Passes through a Category A joint	No

Nozzle

Description	NPS 0,75 XXS DN 20
Access opening	No
Material specification	SA-106 B Smls Pipe (II-D Metric p. 16, In. 16)
Inside diameter, new	11,02 mm
Pipe nominal wall thickness	7,82 mm
Pipe minimum wall thickness ¹	6,85 mm
Corrosion allowance	3 mm
Projection available outside vessel, L _{pr}	64,44 mm
Local vessel minimum thickness	11,11 mm
Liquid static head included	0 bar

Welds

Inner fillet, Leg ₄₁	8 mm
Nozzle to vessel groove weld	12,7 mm

Radiography

Longitudinal seam	Seamless No RT
Circumferential seam	Full UW-11(a) Type 1

¹Pipe minimum thickness = nominal thickness times pipe tolerance factor of 0,875.

UCS-66 Material Toughness Requirements Nozzle

$t_r = \frac{56,38-8,51}{1.180 \cdot 1 - 0,6 \cdot 56,38} =$	0,42 mm
Stress ratio $= \frac{t_r \cdot E^*}{t_n - c} = \frac{0,42 \cdot 1}{6,85 - 3} =$	0,1089
Stress ratio $\leq 0,35$, MDMT per UCS-66(b)(3) =	-105°C
Material is exempt from impact testing at the Design MDMT of 0°C.	

Reinforcement Calculations for Internal Pressure

UG-37 Area Calculation Summary (cm ²)							UG-45 Summary (mm)	
For P = 39 bar @ 135 °C							The nozzle passes UG-45	
A required	A available	A ₁	A ₂	A ₃	A ₅	A welds	t _{req}	t _{min}
This nozzle is exempt from area calculations per UG-36(c)(3)(a)							5,51	6,85

UG-41 Weld Failure Path Analysis Summary
The nozzle is exempt from weld strength calculations per UW-15(b)(2)

UW-16 Weld Sizing Summary			
Weld description	Required weld throat size (mm)	Actual weld throat size (mm)	Status
Nozzle to shell fillet (Leg ₄₁)	3,38	5,6	weld size is adequate

Calculations for internal pressure 39 bar @ 135 °C

Parallel Limit of reinforcement per UG-40

$$\begin{aligned}
 L_R &= \max [d, R_n + (t_n - C_n) + (t - C)] \\
 &= \max [17,02, 8,51 + (7,82 - 3) + (11,11 - 3)] \\
 &= 21,45 \text{ mm}
 \end{aligned}$$

Outer Normal Limit of reinforcement per UG-40

$$\begin{aligned}
 L_H &= \min [2,5 \cdot (t - C), 2,5 \cdot (t_n - C_n) + t_e] \\
 &= \min [2,5 \cdot (11,11 - 3), 2,5 \cdot (7,82 - 3) + 0] \\
 &= 12,06 \text{ mm}
 \end{aligned}$$

Nozzle required thickness per UG-27(c)(1)

$$\begin{aligned}
 t_{rn} &= \frac{P \cdot R_n}{S_n \cdot E - 0,6 \cdot P} \\
 &= \frac{39,0001 \cdot 8,51}{1,180 \cdot 1 - 0,6 \cdot 39,0001} \\
 &= 0,29 \text{ mm}
 \end{aligned}$$

Required thickness t_r from UG-37(a)(c)

$$\begin{aligned}
 t_r &= \frac{P \cdot K_1 \cdot D_o}{2 \cdot S \cdot E + 0,8 \cdot P} \\
 &= \frac{39,0001 \cdot 0,8737 \cdot 219,07}{2 \cdot 1,180 \cdot 1 + 0,8 \cdot 39,0001} \\
 &= 3,12 \text{ mm}
 \end{aligned}$$

Required thickness t_r per Interpretation VIII-1-07-50

$$t_r = \frac{P \cdot D_o \cdot K}{2 \cdot S \cdot E + 2 \cdot P \cdot (K - 0,1)} = \frac{39 \cdot 219,07 \cdot 0,961673}{2 \cdot 1,180 \cdot 0,85 + 2 \cdot 39 \cdot (0,961673 - 0,1)} = 3,96 \text{ mm}$$

This opening does not require reinforcement per UG-36(c)(3)(a)

UW-16(c) Weld Check

Fillet weld: $t_{\min} = \min [19\text{mm}, t_n, t] = 4,82 \text{ mm}$

$$t_{c(\min)} = \min [6 \text{ mm}, 0,7 \cdot t_{\min}] = \underline{3,38} \text{ mm}$$

$$t_{c(\text{actual})} = 0,7 \cdot \text{Leg} = 0,7 \cdot 8 = 5,6 \text{ mm}$$

The fillet weld size is satisfactory.

Weld strength calculations are not required for this detail which conforms to Fig. UW-16.1, sketch (c-e).

UG-45 Nozzle Neck Thickness Check

Interpretation VIII-1-83-66 has been applied.

$$\begin{aligned} t_{aUG-27} &= \frac{P \cdot R_n}{S_n \cdot E - 0,6 \cdot P} + \text{Corrosion} \\ &= \frac{39,0001 \cdot 8,51}{1.180 \cdot 1 - 0,6 \cdot 39,0001} + 3 \\ &= 3,29 \text{ mm} \end{aligned}$$

$$\begin{aligned} t_a &= \max [t_{aUG-27}, t_{aUG-22}] \\ &= \max [3,29, 0] \\ &= 3,29 \text{ mm} \end{aligned}$$

$$\begin{aligned} t_{b1} &= \frac{P \cdot D_o \cdot K}{2 \cdot S \cdot E + 2 \cdot P \cdot (K - 0,1)} + \text{Corrosion} \\ &= \frac{39 \cdot 219,07 \cdot 0,961673}{2 \cdot 1.180 \cdot 1 + 2 \cdot 39 \cdot (0,961673 - 0,1)} + 3 \\ &= 6,38 \text{ mm} \end{aligned}$$

$$\begin{aligned} t_{b1} &= \max [t_{b1}, t_{bUG16}] \\ &= \max [6,39, 4,5] \\ &= 6,39 \text{ mm} \end{aligned}$$

$$\begin{aligned} t_b &= \min [t_{b3}, t_{b1}] \\ &= \min [5,51, 6,39] \\ &= 5,51 \text{ mm} \end{aligned}$$

$$\begin{aligned} t_{UG-45} &= \max [t_a, t_b] \\ &= \max [3,29, 5,51] \\ &= \underline{5,51} \text{ mm} \end{aligned}$$

Available nozzle wall thickness new, $t_n = 0,875 \cdot 7,82 = 6,85 \text{ mm}$

The nozzle neck thickness is adequate.

Reinforcement Calculations for MAWP

The vessel wall thickness governs the MAWP of this nozzle.

UG-37 Area Calculation Summary (cm ²)							UG-45 Summary (mm)	
For P = 103,54 bar @ 135 °C							The nozzle passes UG-45	
A required	A available	A ₁	A ₂	A ₃	A ₅	A welds	t _{req}	t _{min}
This nozzle is exempt from area calculations per UG-36(c)(3)(a)							5,51	6,85

UG-41 Weld Failure Path Analysis Summary
The nozzle is exempt from weld strength calculations per UW-15(b)(2)

UW-16 Weld Sizing Summary			
Weld description	Required weld throat size (mm)	Actual weld throat size (mm)	Status
Nozzle to shell fillet (Leg ₄₁)	3,38	5,6	weld size is adequate

Calculations for internal pressure 103,54 bar @ 135 °C

Parallel Limit of reinforcement per UG-40

$$\begin{aligned}
 L_R &= \max [d, R_n + (t_n - C_n) + (t - C)] \\
 &= \max [17,02, 8,51 + (7,82 - 3) + (11,11 - 3)] \\
 &= 21,45 \text{ mm}
 \end{aligned}$$

Outer Normal Limit of reinforcement per UG-40

$$\begin{aligned}
 L_H &= \min [2,5 \cdot (t - C), 2,5 \cdot (t_n - C_n) + t_e] \\
 &= \min [2,5 \cdot (11,11 - 3), 2,5 \cdot (7,82 - 3) + 0] \\
 &= 12,06 \text{ mm}
 \end{aligned}$$

Nozzle required thickness per UG-27(c)(1)

$$\begin{aligned}
 t_{rn} &= \frac{P \cdot R_n}{S_n \cdot E - 0,6 \cdot P} \\
 &= \frac{103,5405 \cdot 8,51}{1.180 \cdot 1 - 0,6 \cdot 103,5405} \\
 &= 0,79 \text{ mm}
 \end{aligned}$$

Required thickness t_r from UG-37(a)(c)

$$\begin{aligned}
 t_r &= \frac{P \cdot K_1 \cdot D_o}{2 \cdot S \cdot E + 0,8 \cdot P} \\
 &= \frac{103,5405 \cdot 0,8737 \cdot 219,07}{2 \cdot 1.180 \cdot 1 + 0,8 \cdot 103,5405} \\
 &= 8,11 \text{ mm}
 \end{aligned}$$

Required thickness t_r per Interpretation VIII-1-07-50

$$t_r = \frac{P \cdot D_o \cdot K}{2 \cdot S \cdot E + 2 \cdot P \cdot (K - 0,1)} = \frac{103,54 \cdot 219,07 \cdot 0,961673}{2 \cdot 1.180 \cdot 0,85 + 2 \cdot 103,54 \cdot (0,961673 - 0,1)} = 9,99 \text{ mm}$$

This opening does not require reinforcement per UG-36(c)(3)(a)

UW-16(c) Weld Check

Fillet weld: $t_{\min} = \min [19\text{mm}, t_n, t] = 4,82 \text{ mm}$

$t_{c(\min)} = \min [6 \text{ mm}, 0,7 \cdot t_{\min}] = 3,38 \text{ mm}$

$t_{c(\text{actual})} = 0,7 \cdot \text{Leg} = 0,7 \cdot 8 = 5,6 \text{ mm}$

The fillet weld size is satisfactory.

Weld strength calculations are not required for this detail which conforms to Fig. UW-16.1, sketch (c-e).

UG-45 Nozzle Neck Thickness Check

Interpretation VIII-1-83-66 has been applied.

$$\begin{aligned} t_{aUG-27} &= \frac{P \cdot R_n}{S_n \cdot E - 0,6 \cdot P} + \text{Corrosion} \\ &= \frac{103,5405 \cdot 8,51}{1,180 \cdot 1 - 0,6 \cdot 103,5405} + 3 \\ &= 3,79 \text{ mm} \end{aligned}$$

$$\begin{aligned} t_a &= \max [t_{aUG-27}, t_{aUG-22}] \\ &= \max [3,79, 0] \\ &= 3,79 \text{ mm} \end{aligned}$$

$$\begin{aligned} t_{b1} &= \frac{P \cdot D_o \cdot K}{2 \cdot S \cdot E + 2 \cdot P \cdot (K - 0,1)} + \text{Corrosion} \\ &= \frac{103,54 \cdot 219,07 \cdot 0,961673}{2 \cdot 1,180 \cdot 1 + 2 \cdot 103,54 \cdot (0,961673 - 0,1)} + 3 \\ &= 11,59 \text{ mm} \end{aligned}$$

$$\begin{aligned} t_{b1} &= \max [t_{b1}, t_{bUG16}] \\ &= \max [11,59, 4,5] \\ &= 11,59 \text{ mm} \end{aligned}$$

$$\begin{aligned} t_b &= \min [t_{b3}, t_{b1}] \\ &= \min [5,51, 11,59] \\ &= 5,51 \text{ mm} \end{aligned}$$

$$\begin{aligned} t_{UG-45} &= \max [t_a, t_b] \\ &= \max [3,79, 5,51] \\ &= 5,51 \text{ mm} \end{aligned}$$

Available nozzle wall thickness new, $t_n = 0,875 \cdot 7,82 = 6,85 \text{ mm}$

The nozzle neck thickness is adequate.

Reinforcement Calculations for MAP

The vessel wall thickness governs the MAP of this nozzle.

UG-37 Area Calculation Summary (cm ²)							UG-45 Summary (mm)	
For P = 139,29 bar @ 21,11 °C							The nozzle passes UG-45	
A required	A available	A ₁	A ₂	A ₃	A ₅	A welds	t _{req}	t _{min}
This nozzle is exempt from area calculations per UG-36(c)(3)(a)							2,51	6,85

UG-41 Weld Failure Path Analysis Summary
The nozzle is exempt from weld strength calculations per UW-15(b)(2)

Calculations for internal pressure 139,29 bar @ 21,11 °C

Parallel Limit of reinforcement per UG-40

$$\begin{aligned}
 L_R &= \max [d, R_n + (t_n - C_n) + (t - C)] \\
 &= \max [11,02, 5,51 + (7,82 - 0) + (11,11 - 0)] \\
 &= 24,45 \text{ mm}
 \end{aligned}$$

Outer Normal Limit of reinforcement per UG-40

$$\begin{aligned}
 L_H &= \min [2,5 \cdot (t - C), 2,5 \cdot (t_n - C_n) + t_e] \\
 &= \min [2,5 \cdot (11,11 - 0), 2,5 \cdot (7,82 - 0) + 0] \\
 &= 19,56 \text{ mm}
 \end{aligned}$$

Nozzle required thickness per UG-27(c)(1)

$$\begin{aligned}
 t_{rn} &= \frac{P \cdot R_n}{S_n \cdot E - 0,6 \cdot P} \\
 &= \frac{139,2932 \cdot 5,51}{1.180 \cdot 1 - 0,6 \cdot 139,2932} \\
 &= 0,7 \text{ mm}
 \end{aligned}$$

Required thickness t_r from UG-37(a)(c)

$$\begin{aligned}
 t_r &= \frac{P \cdot K_1 \cdot D_o}{2 \cdot S \cdot E + 0,8 \cdot P} \\
 &= \frac{139,2932 \cdot 0,9 \cdot 219,07}{2 \cdot 1.180 \cdot 1 + 0,8 \cdot 139,2932} \\
 &= 11,11 \text{ mm}
 \end{aligned}$$

Required thickness t_r per Interpretation VIII-1-07-50

$$t_r = \frac{P \cdot D_o \cdot K}{2 \cdot S \cdot E + 2 \cdot P \cdot (K - 0,1)} = \frac{139,29 \cdot 219,07 \cdot 1}{2 \cdot 1.180 \cdot 0,85 + 2 \cdot 139,29 \cdot (1 - 0,1)} = 13,52 \text{ mm}$$

This opening does not require reinforcement per UG-36(c)(3)(a)

UG-45 Nozzle Neck Thickness Check

Interpretation VIII-1-83-66 has been applied.

$$\begin{aligned}t_{aUG-27} &= \frac{P \cdot R_n}{S_n \cdot E - 0,6 \cdot P} + \text{Corrosion} \\ &= \frac{139,2932 \cdot 5,51}{1.180 \cdot 1 - 0,6 \cdot 139,2932} + 0 \\ &= 0,7 \text{ mm}\end{aligned}$$

$$\begin{aligned}t_a &= \max [t_{aUG-27}, t_{aUG-22}] \\ &= \max [0,7, 0] \\ &= 0,7 \text{ mm}\end{aligned}$$

$$\begin{aligned}t_{b1} &= \frac{P \cdot D_o \cdot K}{2 \cdot S \cdot E + 2 \cdot P \cdot (K - 0,1)} + \text{Corrosion} \\ &= \frac{139,29 \cdot 219,07 \cdot 1}{2 \cdot 1.180 \cdot 1 + 2 \cdot 139,29 \cdot (1 - 0,1)} + 0 \\ &= 11,69 \text{ mm}\end{aligned}$$

$$\begin{aligned}t_{b1} &= \max [t_{b1}, t_{bUG16}] \\ &= \max [11,69, 1,5] \\ &= 11,69 \text{ mm}\end{aligned}$$

$$\begin{aligned}t_b &= \min [t_{b3}, t_{b1}] \\ &= \min [2,51, 11,69] \\ &= 2,51 \text{ mm}\end{aligned}$$

$$\begin{aligned}t_{UG-45} &= \max [t_a, t_b] \\ &= \max [0,7, 2,51] \\ &= 2,51 \text{ mm}\end{aligned}$$

Available nozzle wall thickness new, $t_n = 0,875 \cdot 7,82 = 6,85 \text{ mm}$

The nozzle neck thickness is adequate.

B16.9 Elbow #2 (N2)

ASME Section VIII Division 1, 2021 Edition Metric				
Component		ASME B16.9 Elbow		
Type		Long Radius 90-deg		
Material		SA-234 WPB (II-D Metric p. 16, In. 18)		
Pipe NPS and Schedule		NPS 0,75 XXS DN 20		
Attached To		Air Outlet (N2)		
Impact Tested	Normalized	Fine Grain Practice	PWHT	Maximize MDMT/ No MAWP
No	No	No	No	No
		Design Pressure (bar)	Design Temperature (°C)	Design MDMT (°C)
Internal		39	135	0
Static Liquid Head				
Condition		P_s (bar)	H_s (mm)	SG
Test horizontal		0,03	255,51	1
Dimensions				
Outer Diameter		26,67 mm		
Nominal Thickness		7,82 mm		
Minimum Thickness¹		6,85 mm		
Center-to-End, A		38 mm		
Corrosion	Inner	3 mm		
	Outer	0 mm		
Weight and Capacity				
		Weight (kg)	Capacity (liters)	
New		0,22	0,01	
Corroded		0,16	0,01	
Radiography				
Longitudinal seam		Seamless No RT		
Left Circumferential seam		Full UW-11(a) Type 1		
Right Circumferential seam		Full UW-11(a) Type 1		

¹ minimum thickness = nominal thickness times pipe tolerance factor of 0,875.

ASME B16.5-2017 Flange	
Description	NPS 0,75 Class 600 WN A105
Bolt Material	SA-193 B7 Bolt <= 64 (II-D Metric p. 410, In. 32)
Blind included	No
Rated MDMT	-44,78°C
Liquid static head	0 bar
MAWP rating	91,1 bar @ 135°C
MAP rating	102,1 bar @ 21,11°C
Hydrotest rating	154 bar @ 21,11°C
PWHT performed	No
Produced to Fine Grain Practice and Supplied in Heat Treated Condition	No
Impact Tested	No
Circumferential joint radiography	Full UW-11(a) Type 1
Bore diameter, B (specified by purchaser)	20,83 mm
Gasket	
Type	ASME B16.20 Spiral-Wound
Description	Garlock FLEXSEAL RW 316L SS / Flexible Graphite
Factor, m	3
Seating Stress, y	703,07 kgf/cm ²
Thickness, T	3 mm
Inner Diameter	25,4 mm
Outer Diameter	39,6 mm
Notes	
Flange rated MDMT per UCS-66(b)(1)(b) = -44,78°C (Coincident ratio = 0,5522) Bolts rated MDMT per Fig UCS-66 note (c) = -48°C	

Results Summary	
Governing condition	UG-16
Minimum thickness per UG-16	1,5 mm + 3 mm = 4,5 mm
Design thickness due to internal pressure (t)	3.43 mm
Maximum allowable working pressure (MAWP)	401.45 bar
Maximum allowable pressure (MAP)	849.81 bar
Rated MDMT	-105 °C

UCS-66 Material Toughness Requirements	
$t_r = 13,34 \cdot \left(1 - \exp\left(-\frac{56,38}{1.180 \cdot 1} \right) \right) =$	0,62 mm
Stress ratio = $\frac{t_r \cdot E^*}{t_n - c} = \frac{0,62 \cdot 1}{6,85 - 3} =$	0,1618
Stress ratio $\leq 0,35$, MDMT per UCS-66(b)(3) =	-105°C
Material is exempt from impact testing at the Design MDMT of 0°C.	

Design thickness, (at 135 °C) Appendix 1-2

$$t = R_o \cdot \left(1 - \exp\left[-\frac{P}{S \cdot E} \right] \right) + \text{Corrosion} = 13,34 \cdot \left(1 - \exp\left[-\frac{39}{1.180 \cdot 1,00} \right] \right) + 3 = \text{3.43 mm}$$

Maximum allowable working pressure, (at 135 °C) Appendix 1-2

$$P = S \cdot E \cdot \ln\left(\frac{R_o}{R_o - t}\right) - P_s = 1.180 \cdot 1,00 \cdot \ln\left(\frac{13,34}{13,34 - (7,82 \cdot 0,875 - 3)}\right) - 0 = \underline{401,45} \text{ bar}$$

Maximum allowable pressure, (at 21,11 °C) Appendix 1-2

$$P = S \cdot E \cdot \ln\left(\frac{R_o}{R_o - t}\right) = 1.180 \cdot 1,00 \cdot \ln\left(\frac{13,34}{13,34 - (7,82 \cdot 0,875)}\right) = \underline{849,81} \text{ bar}$$

Supports detail

Scale 1 : 3

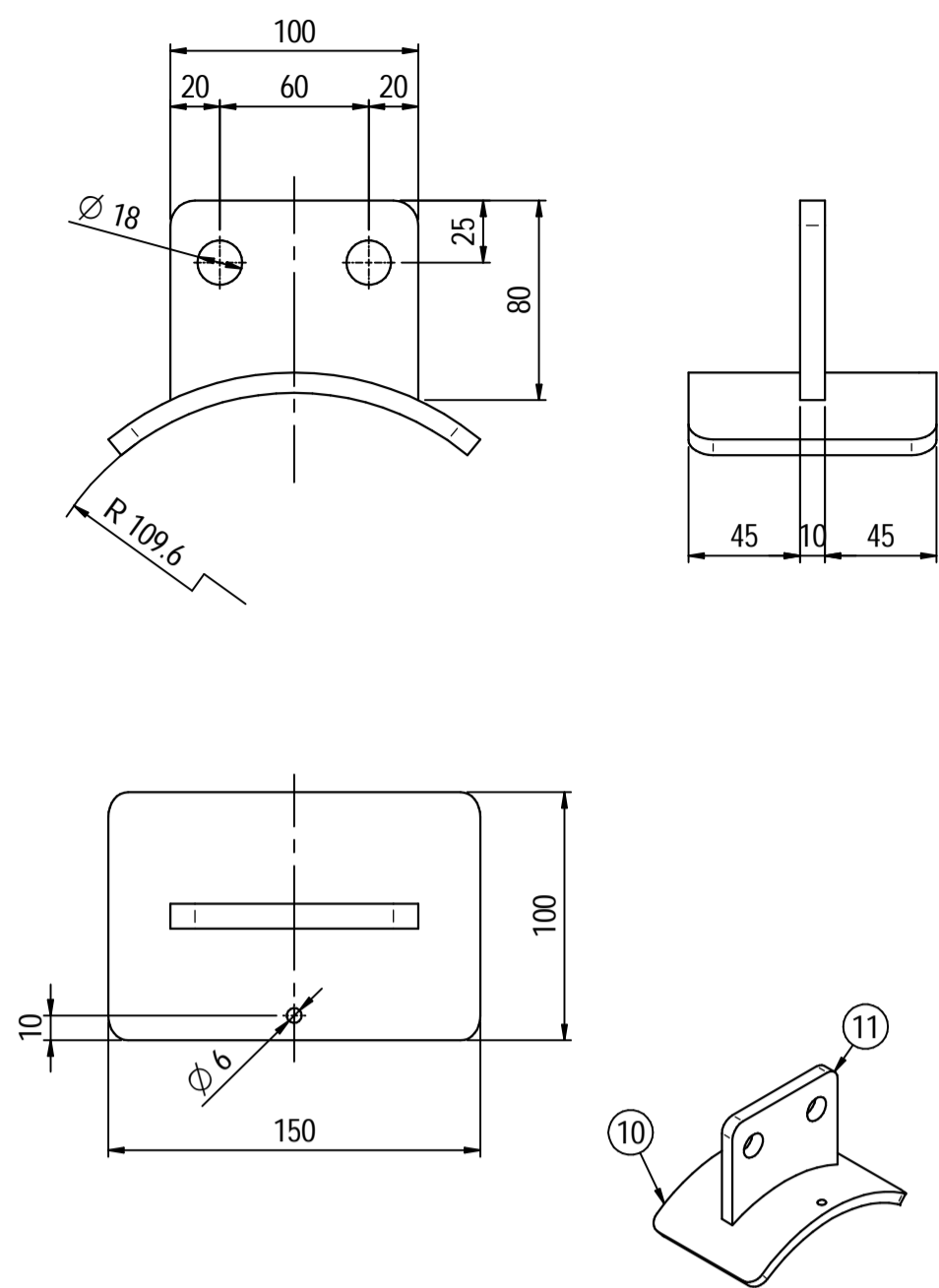

Nameplate detail

Scale 1:5

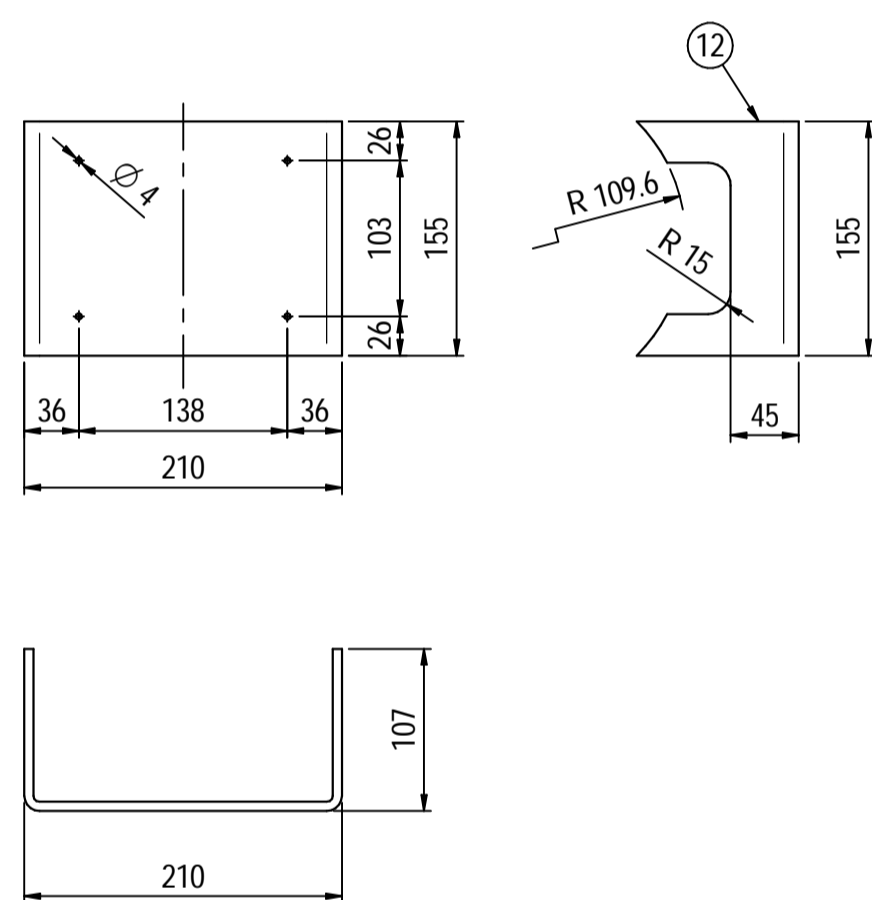

Nameplate detail

scale 1:1.5

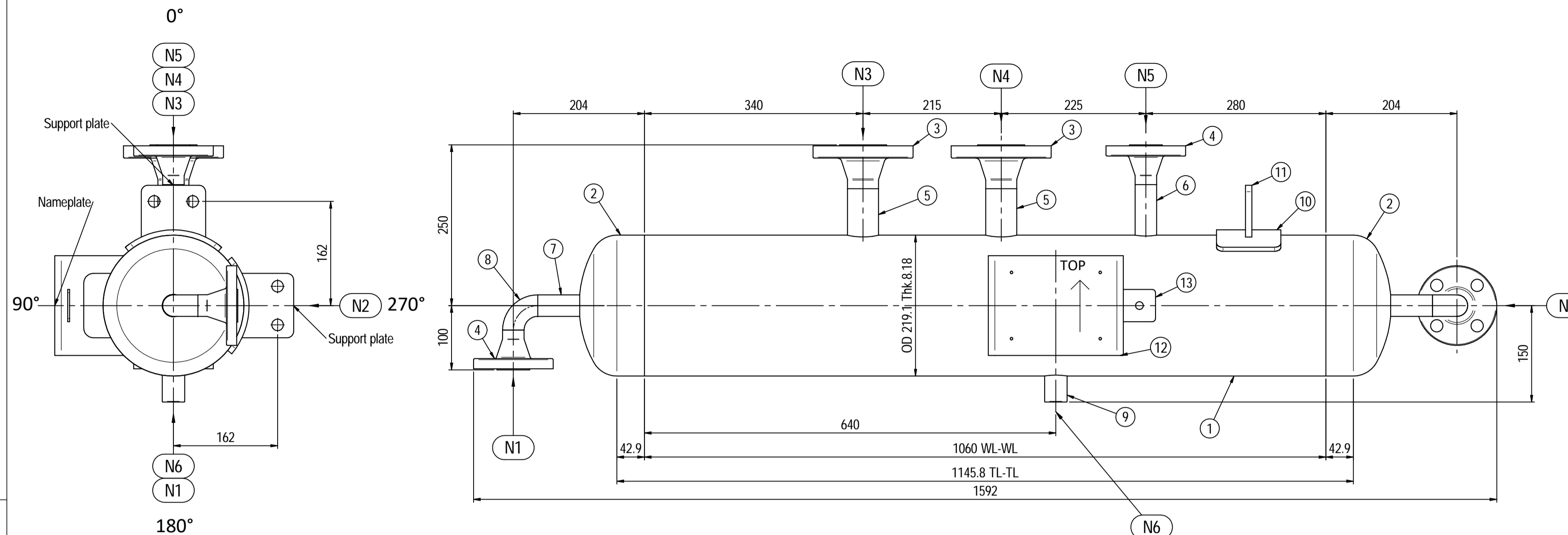
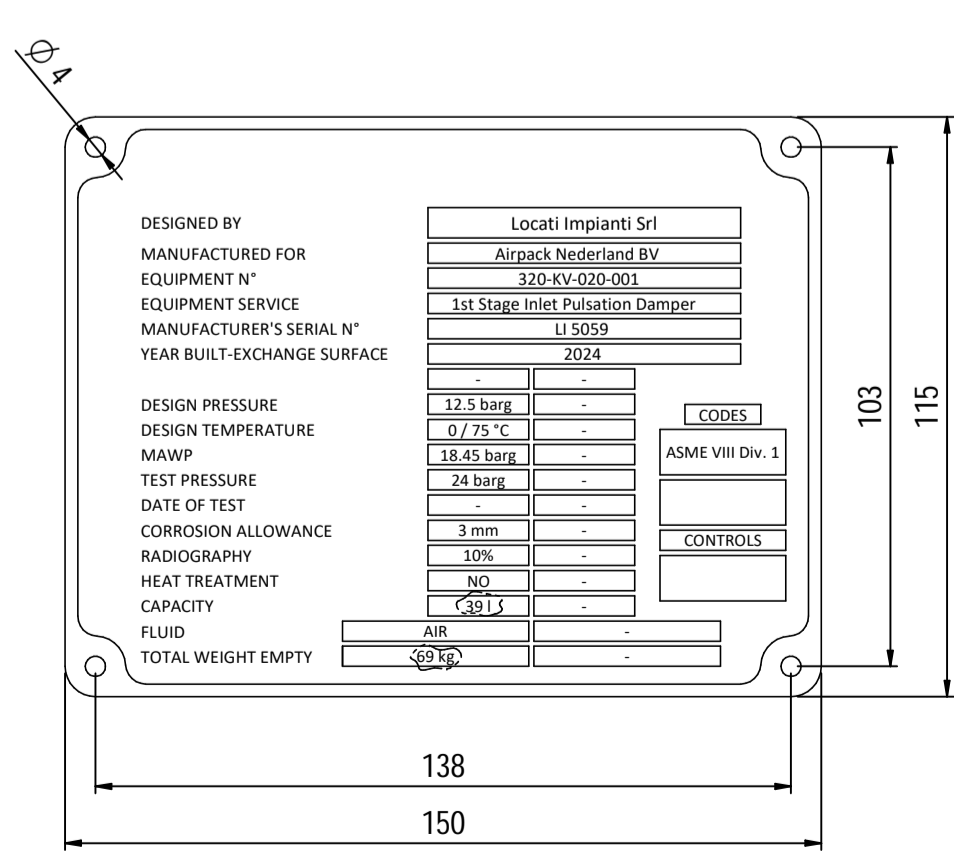

ORIENTATION VIEW

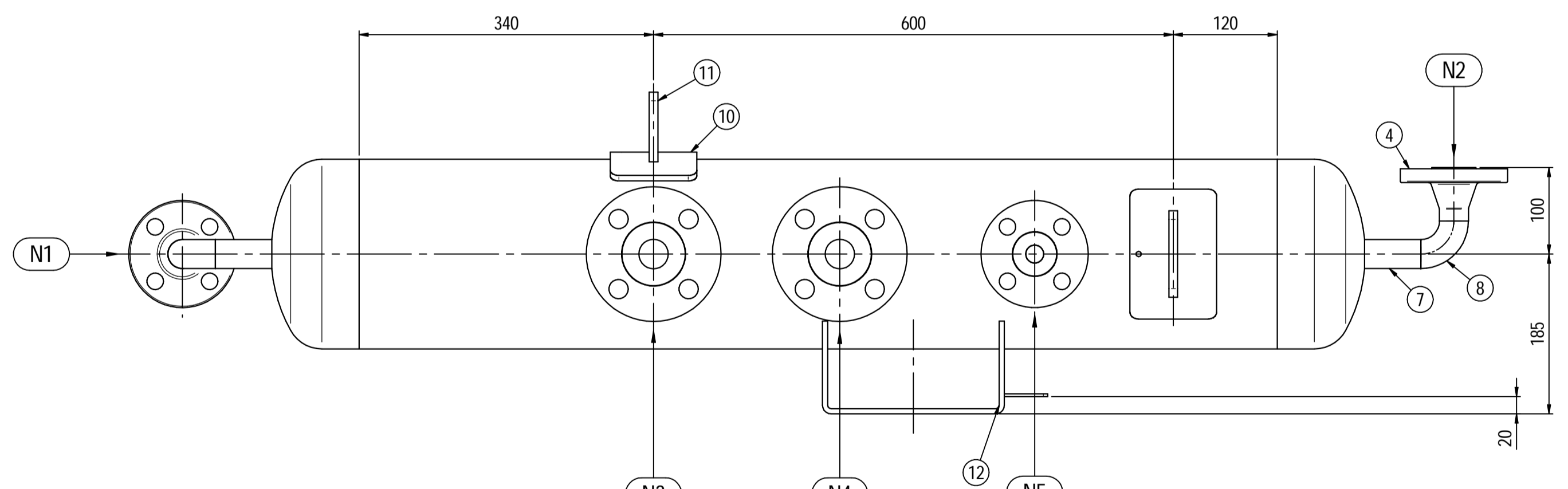

PLAN VIEW

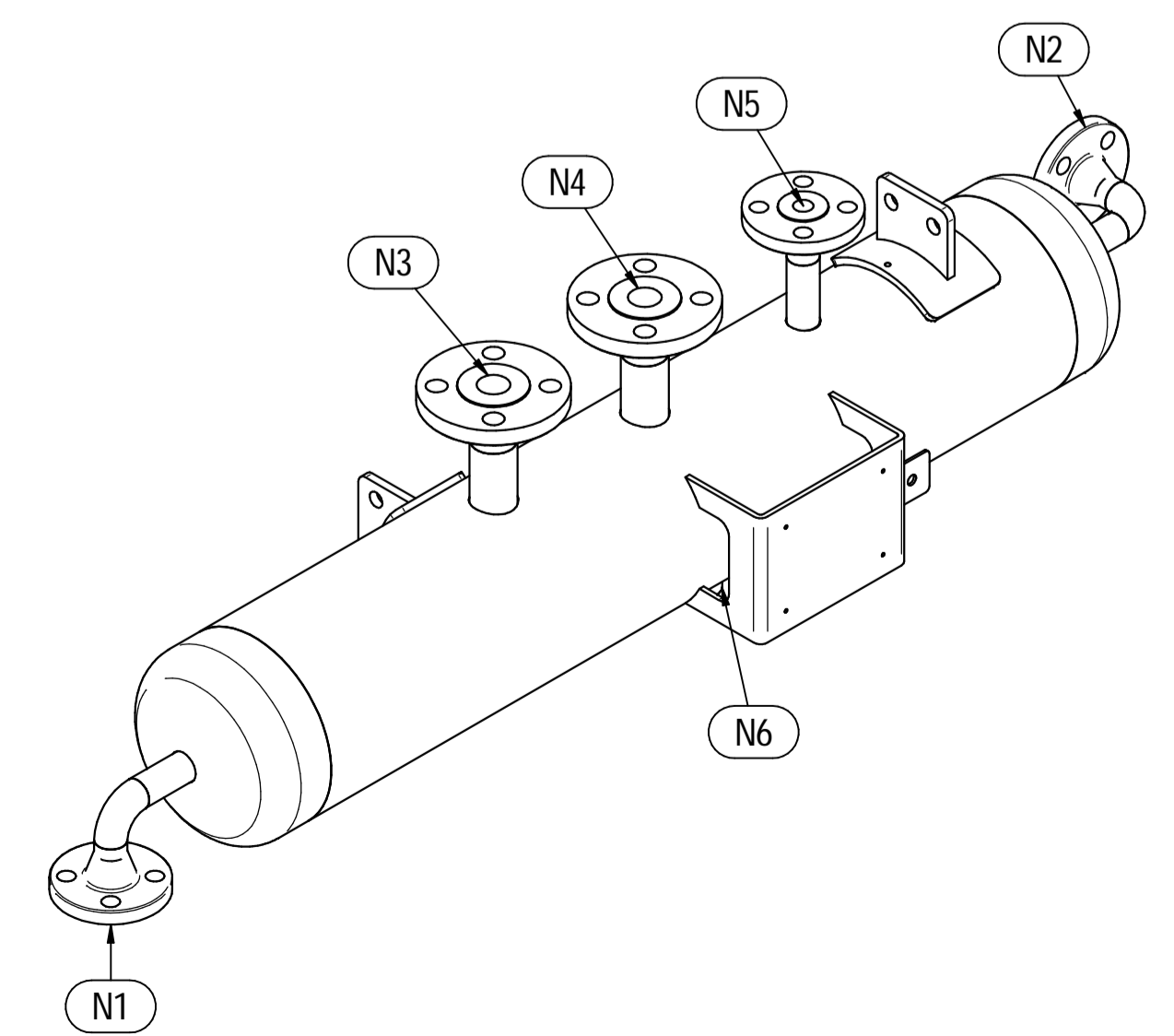

ISOMETRIC VIEW

Pos.	QTY	Description	Material	Cert.
1	1	Shell by Seamless Pipe 8" Sch.40 L=1060	SA106 Gr.B	3.1
2	2	Cap 8" Sch.40	SA234 WPB	3.1
3	2	Flange 1 1/2" WN #300 RF Sch.160	A105	3.1
4	3	Flange 1" WN #300 RF Sch.160	SA105	3.1
5	2	Seamless Pipe 1 1/2" Sch.160 L=75	SA106 Gr.B	3.1
6	1	Seamless Pipe 1" Sch.160 L=80	SA106 Gr.B	3.1
7	2	Seamless Pipe 1" Sch.160 L=73	SA106 Gr.B	3.1
8	2	Seamless elbow 1" 90° LR Sch.160	SA234 WPB	3.1
9	1	Coupling 1/2" NPT #6000	A105	3.1
10	2	Pad by pipe 100 x 150 Thk.8.18	SA106 Gr.B	
11	2	Support plate 100 x 80 Thk.10	SA516 70	
12	1	Nameplate support by plate 403 x 155 Thk.6	SA516 70	
13	1	Earthing plate 50 x 40 Thk.3	SA240 TP316L	

- Note:**
- Governing measurement S.I. unless otherwise specified
 - Flange bolt holes have to be straddled from main vessel center line in plan & vertical & horizontal centreline in elevation
 - Material: certification 3.1 EN 10204
 - All internal edge shall be rounded off
 - Nozzle flanges in accordance with ASME B16.5: 2020
 - Flange fittings in accordance with ASME B16.9: 2018
 - All fillet welds not detailed on "WELDING MAP" or drawing shall have the weld throated equal to 0.7 times the minimum thickness to be welded
 - All welds are continuous except where indicate
 - Delated
 - The nameplate ise in SS316 and is laser engraved
 - Non corrosive service, no inspection opening per UG-46(a)
 - On support hexagonal bolts DIN 933, class 8.8 shall be use (Airpack scope)

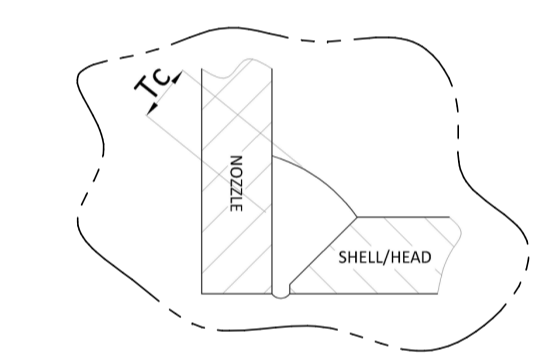

ITEM	QTY	SERVICE	SIZE	O.D.	THK	RATING	TYPE	FACE	O.D.	THK.	Tc
N6	1	DRAIN	1/2"	38.1	8.38	#6000	NPT-F	-	-	-	8±10
N5	1	PSV CONNECTION	1"	33.4	6.35	#300	WN	RF	-	-	8±10
N4	1	TEMPERATURE GAUGE	1 1/2"	48.3	7.14	#300	WN	RF	-	-	8±10
N3	1	TEMPERATURE TRANSMITTER	1 1/2"	48.3	7.14	#300	WN	RF	-	-	8±10
N2	1	AIR OUTLET	1"	33.4	6.35	#300	WN	RF	-	-	8±10
N1	1	AIR INLET	1"	33.4	6.35	#300	WN	RF	-	-	8±10

ITEM	Qtà	SERVIZIO	NPS/DN	O.D.	THK	RATING	TYPE	FACE	O.D.	THK.
							FLANGIA			
							FLANGIA			
							FLANGIA			
							FLANGIA			
							FLANGIA			

Rev.	Descrizione / Description	Disegnato/Draw	Controllato/Checked	Approvato/Approved	Data/Date
03	Issue for approval	LG	MV	MV	11/09/2024
02	Modified total volume	LG	MV	MV	03/08/2024
01	Revised as per Customer comments	LG	MV	MV	11/05/2024
00	FIRST ISSUE	LG	MV	MV	03/02/2024

Scala/Scale	1 : 5	Formato/Size	A1
Comm. N°/Job No.	C230048	Foglio/Sheet	1 - 1
Cliente/Customer	Airpack Nederland B.V.		
Ord. No.	17735-VV-900 (SK)		
Dis. N°/Dwg No.	C230048DWG001	Rev.	03

Supports detail

Scale 1 : 3

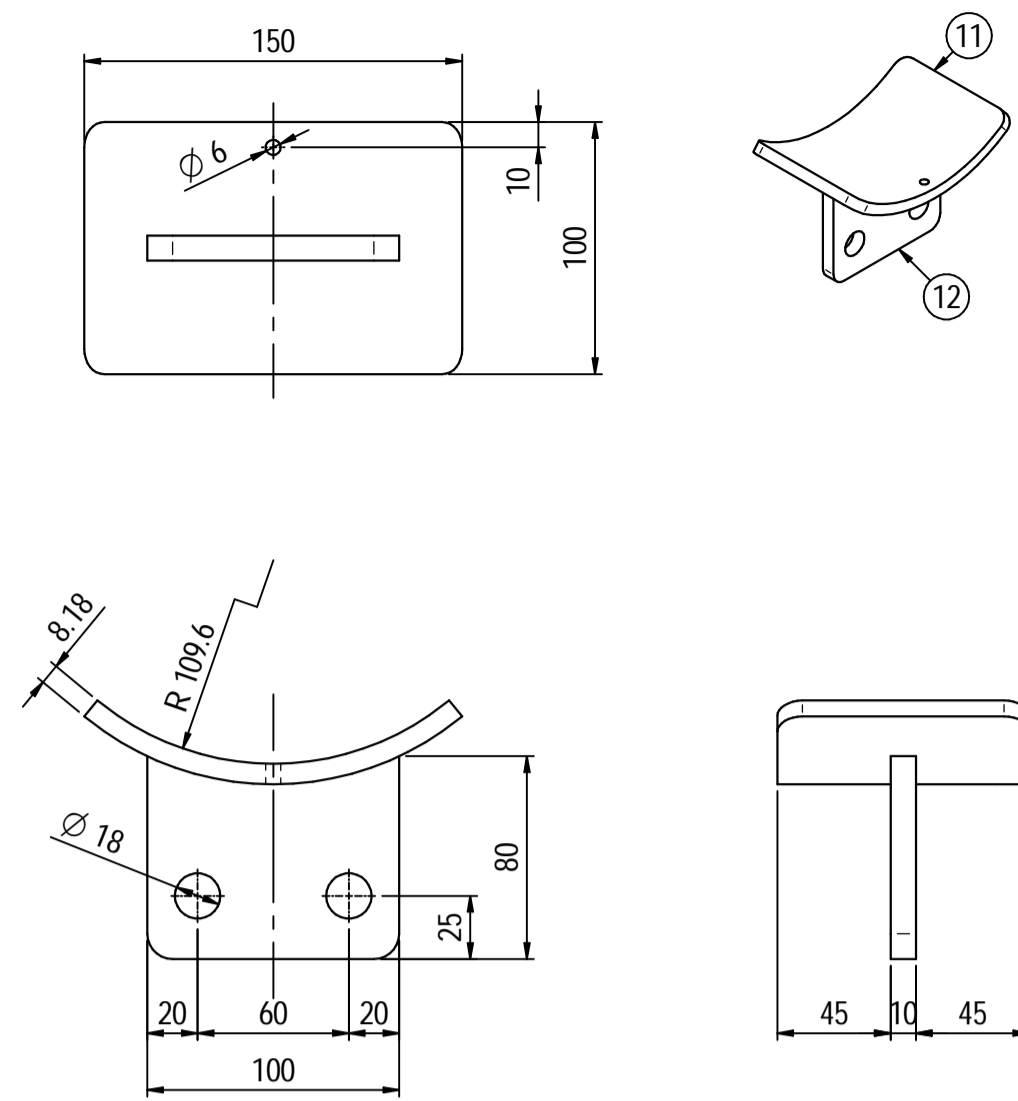

Nameplate detail

Scale 1:5

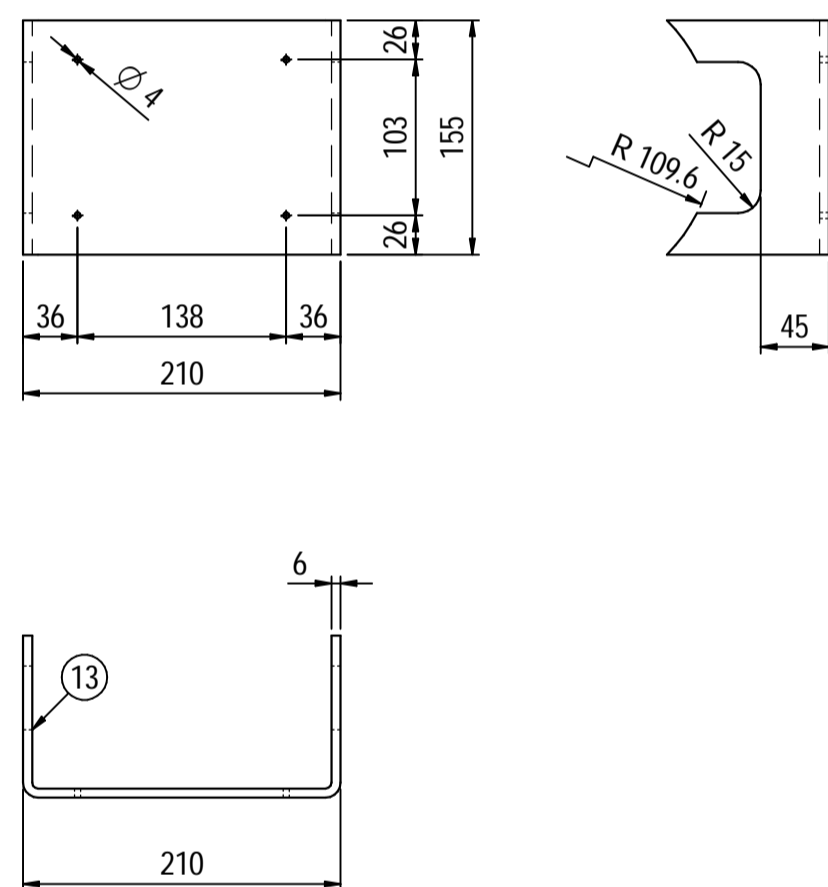

Nameplate detail

scale 1:1.5

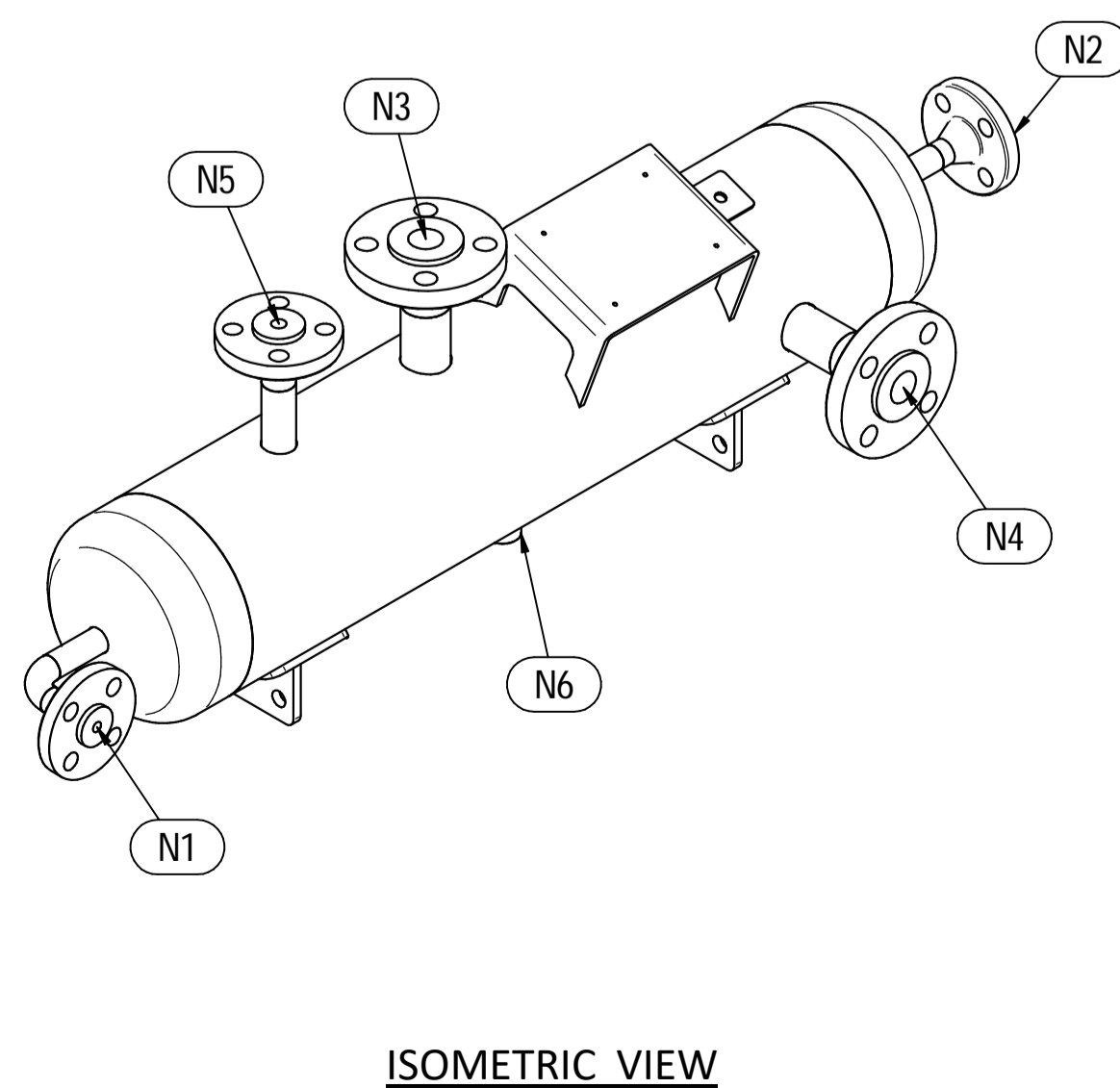
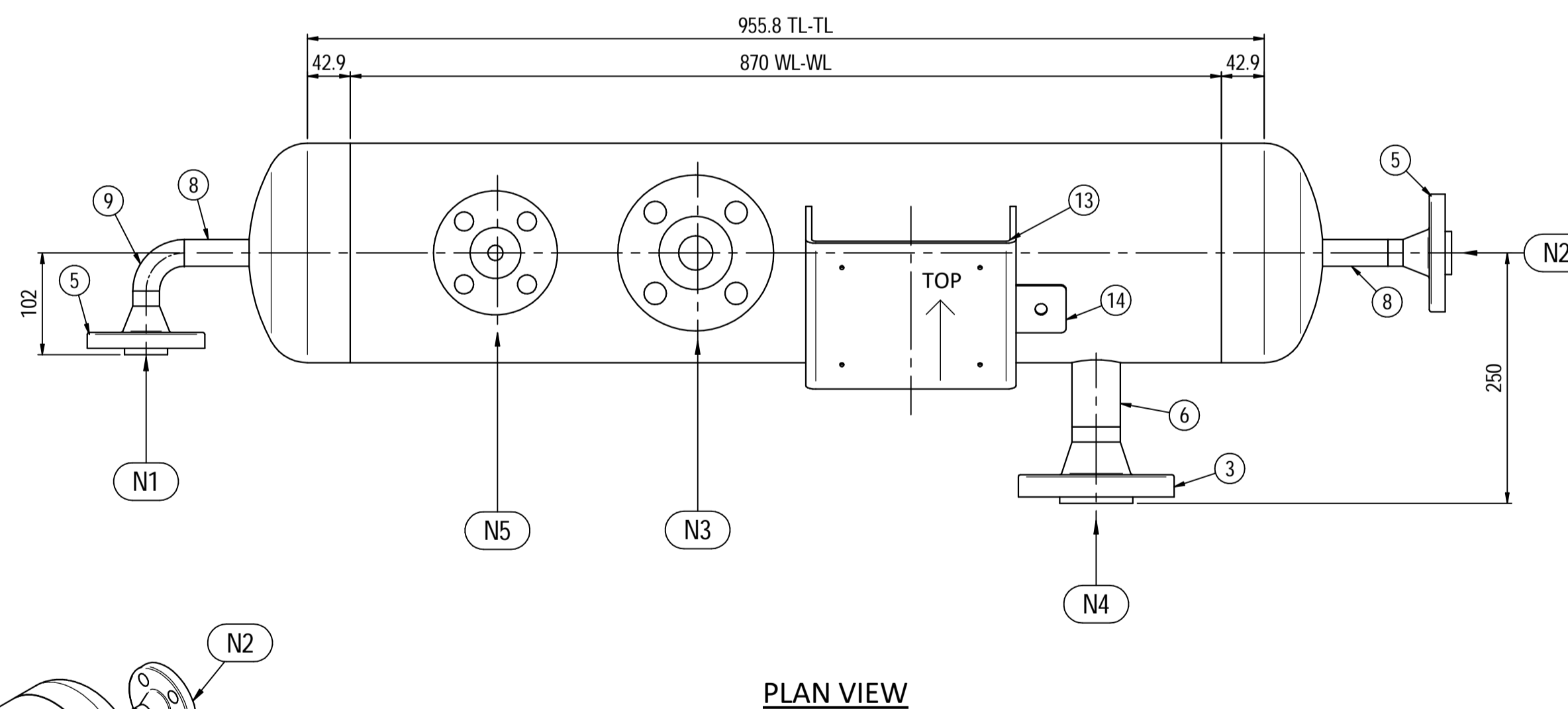
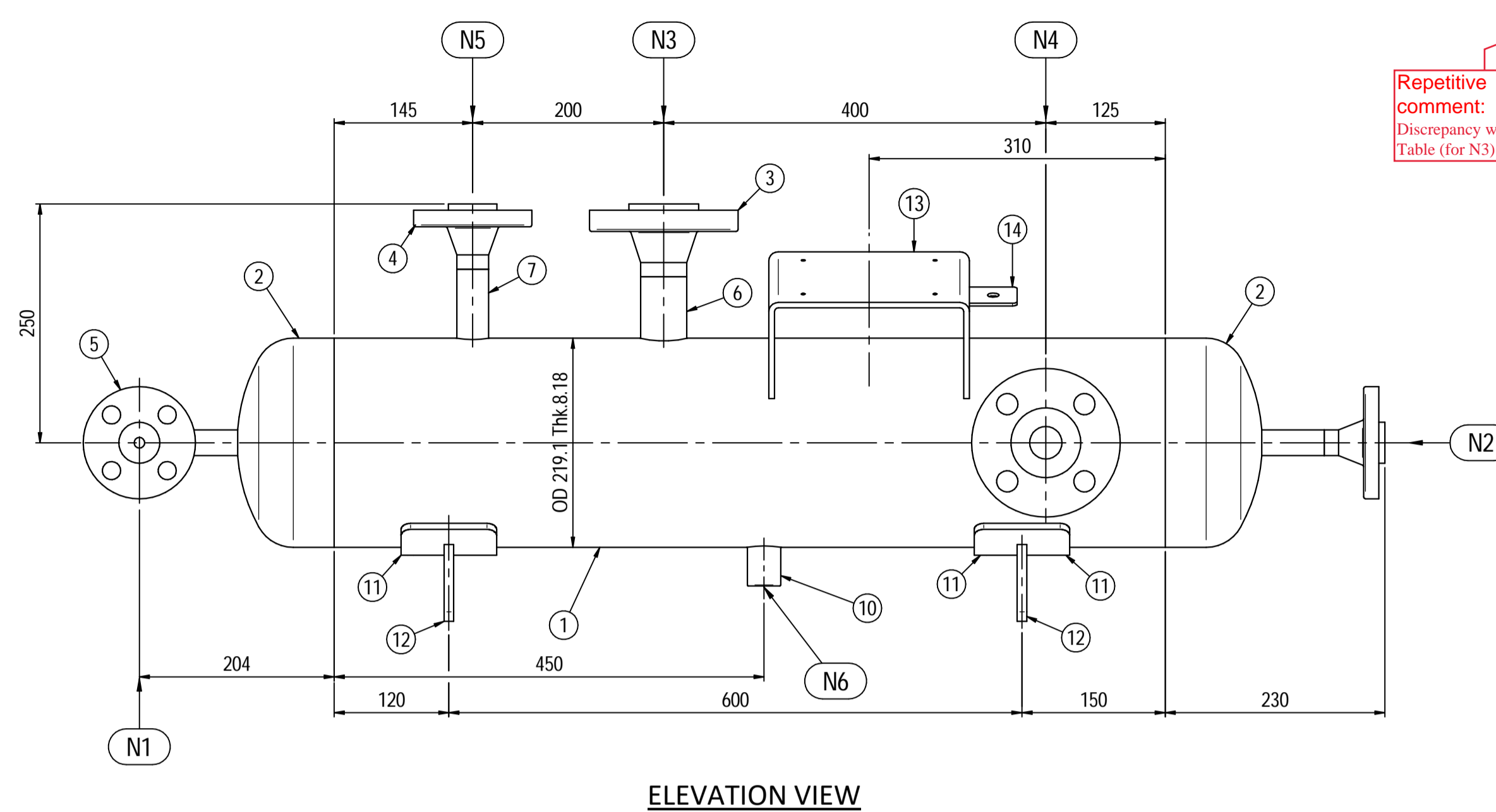
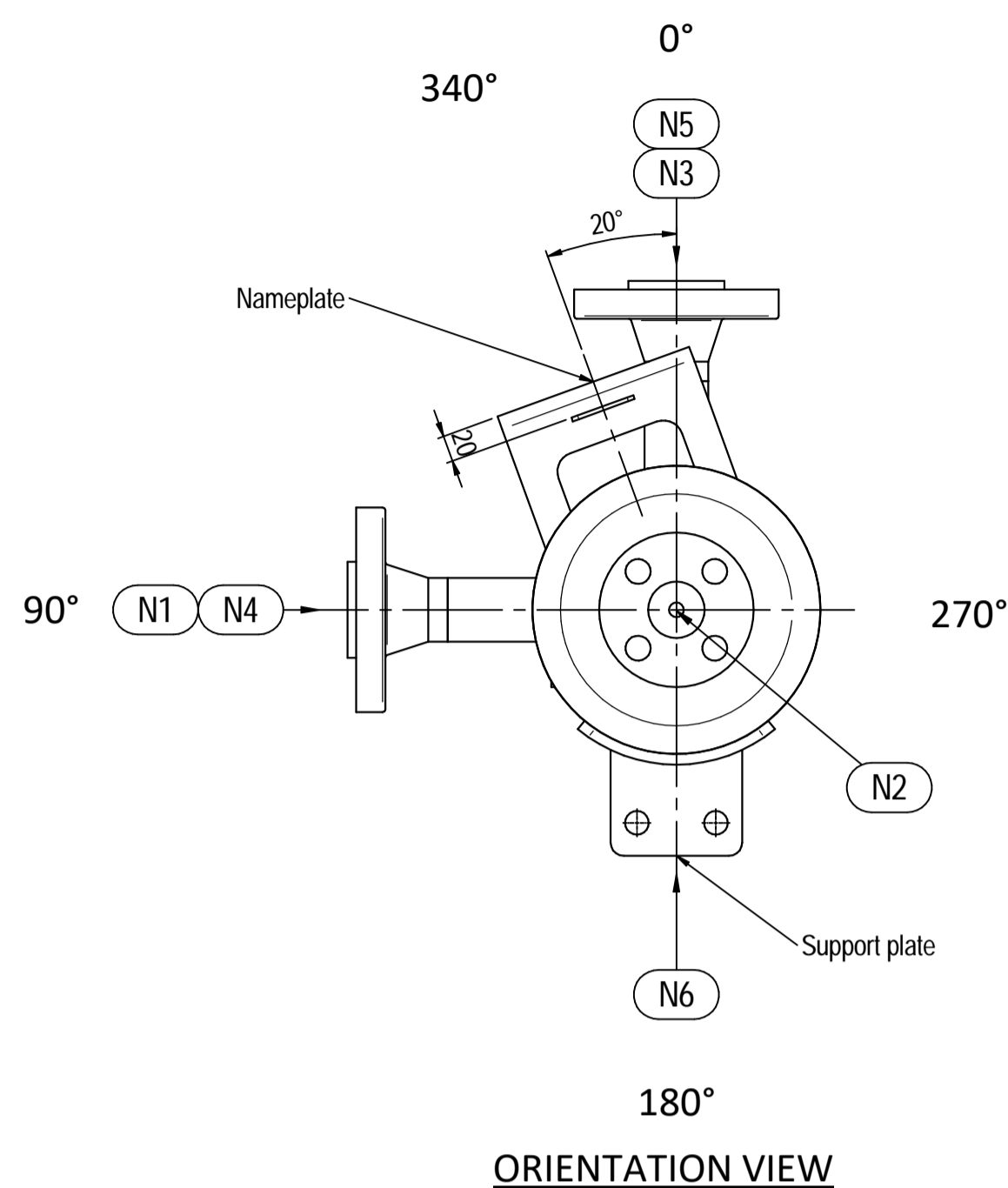
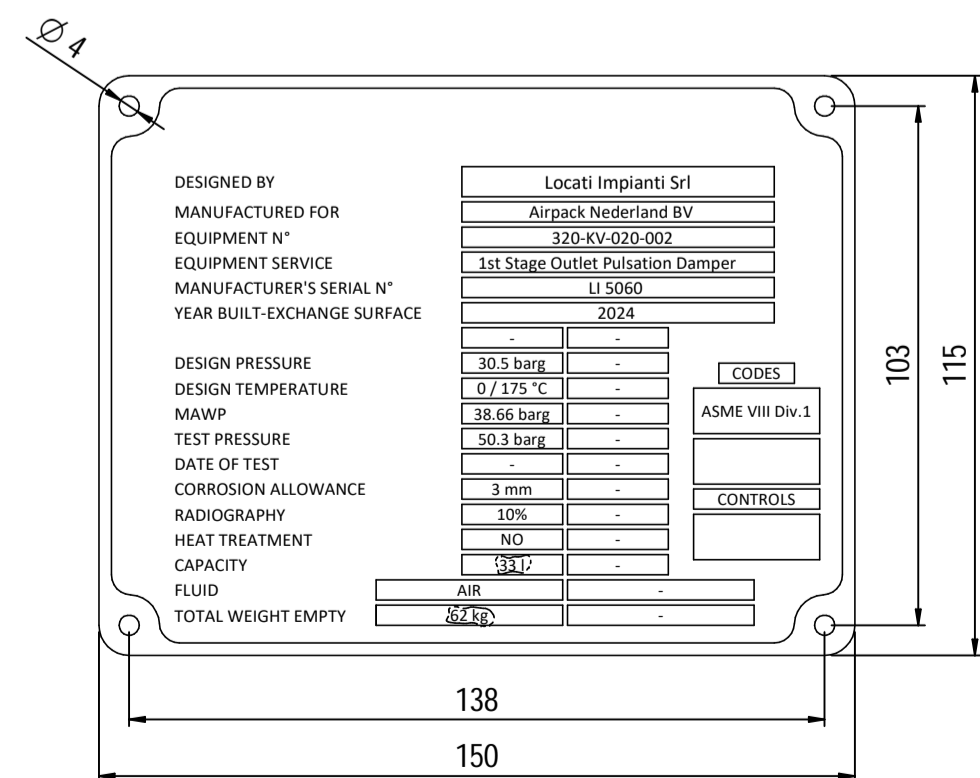

Pos.	QTY	Description	Material	Cert.
1	1	Shell by Seamless Pipe 8" Sch.40 L=870	SA106 Gr.B	3.1
2	2	Cap 8" Sch.40	SA234 WPB	3.1
3	2	Flange 1 1/2" WN #600 RF Sch.160	SA105	3.1
4	1	Flange 1" WN #600 RF Sch.XXS	SA105	3.1
5	2	Flange 3/4" WN #600 RF Sch.XXS	SA105	3.1
6	2	Seamless Pipe 1 1/2" Sch.160 L=75	SA106 Gr.B	3.1
7	1	Seamless Pipe 1" Sch.XXS L=80	SA106 Gr.B	3.1
8	2	Seamless Pipe 3/4" Sch.XXS L=73	SA106 Gr.B	3.1
9	1	Seamless elbow 3/4" 90° LR Sch.XXS	SA234 WPB	3.1
10	1	Coupling 3/4" NPT #6000	A105	3.1
11	2	Pad by pipe 100 x 150 Thk.8.18	SA106 Gr.B	
12	1	Plate 100 x 80 Thk.10	SA516 70	
13	1	Support by plate 403 x 155 Thk.6	SA516 70	
14	1	Plate 50 x 40 Thk.3	SA240 TP316L	

Repetitive comment: Discrepancy with Nozzle Table (for N3)

Repetitive comment: Discrepancy with Nozzle Table (for N5)

- Note:
- 1) Governing measurement S.I. unless otherwise specified
 - 2) Flange bolt holes have to be straddled from main vessel center line in plan & vertical & horizontal centreline in elevation
 - 3) Material: certification 3.1 EN 10204
 - 4) All internal edge shall be rounded off
 - 5) Nozzle flanges in accordance with ASME B16.5: 2020
 - 6) Flange fittings in accordance with ASME B16.9: 2018
 - 7) All fillet welds not detailed on "WELDING MAP" or drawing shall have the weld throated equal to 0.7 times the minimum thickness to be welded
 - 8) All welds are continuous except where indicate
 - 9) Deleted
 - 10) The nameplate use in SS316 and is laser engraved
 - 11) Non corrosive service, no inspection opening per UG-46(a)
 - 12) On support hexagonal bolts DIN 933, class 8.8 shall be use (Airpack scope)

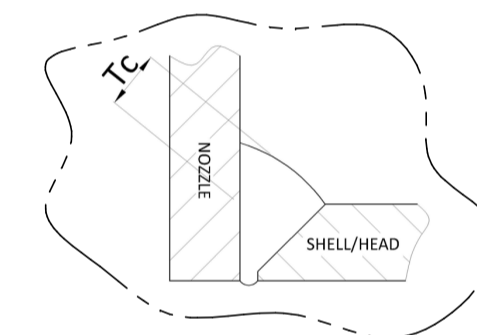

ITEM	QTY	DESCRIPTION	SIZE	O.D.	THK	RATING	TYPE	FACE	O.D.	THK.	Tc
N6	1	DRAIN	1/2"	38.1	8.38	#6000	NPT-F	-	-	-	8 ± 10
N5	1	TEMPERATURE GAUGE	1 1/2"	48.3	7.14	#600	WN RF	-	-	-	8 ± 10
N4	1	TEMPERATURE TRANSMITTER	1 1/2"	48.3	7.14	#600	WN RF	-	-	-	8 ± 10
N3	1	PSV CONNECTION	1"	33.4	5.09	#600	WN RF	-	-	-	8 ± 10
N2	1	AIR OUTLET	3/4"	26.7	7.82	#600	WN RF	-	-	-	8 ± 10
N1	1	AIR INLET	3/4"	26.7	7.82	#600	WN RF	-	-	-	8 ± 10

Repetitive comment: As per calculation thickness of N5 is 9.09 and N3 is 7.14. please revise.

ITEM	Qtà	DESCRIPTION	FACE	O.D.	THK.	RINFORZO
ITEM	Qtà	DESCRIPTION	FACE	O.D.	THK.	RINFORZO

FLUIDO	COLLAUDO	0094 Iqqa Inspection Iberia SA
Fluid	Test	
STATO FISICO DEL FLUIDO	PED	N/A
Physical state of fluid		
CODICE DI CALCOLO	ASME VIII Div.1 Ed.2021	
Construction code		
PRESSIONE DI ESERCIZIO	SERVIZIO LETALE	NO
Operating pressure	Lethal service	
PRESSIONE DI PROGETTO	X-RAY	Spot (10%)
Design pressure	RT examination	
PRESSIONE ESTERNA	LIQUIDI PENETRANTI	NO
External pressure	Dye penetrant extension	
PRESSIONE DI PROVA IDRAULICA	ULTRASUONI	NO
Hydraulic test pressure	Ultrasonic extension	
TEMPERATURA DI ESERCIZIO	CONTROLLO MAGNETOSCOPICO	NO
Operating temperature	Magnetic particle examination	
TEMPERATURA DI PROGETTO	TALONE DI SALDATURA	NO
Design temperature	Weld test coupon	
SOVRAMESTO DI CORROSIONE	PROCEDIMENTO DI SALDATURA	See doc: C230048WBK009
Corrosion allowance	Welding procedure	
CAPACITA'	TIPO DI FONDO	CAP
Capacity	Head type	
EFFICIENZA GIUNTI	FORMAZIONE FONDO	HOT
Joint efficiency	Head form	
MAWP @ Design Temperature	PESO A VUOTO	62 kg
38.66 barg @ +175° C	Empty weight	
MAWP(EXT)	PESO IN ESERCIZIO	62 kg
NO	Operating weight	
MDMT @ MAWP	PESO PIENO D'ACQUA	95 kg
0 ° C @ 38.66 barg	Full water weight	
TRATTAMENTO TERMICO	DATI DEL VENTO	
NO	Wind datas	
P.W.H.T.	DATI SISMICI	
IMPACT TEST	Seismological datas	
Exemption		

Rev.	Descrizione / Description	Disegnato/Draw	Controllato/Checked	Approvato/Approved	Data/Date
03	Issue for approval	LG	MV	MV	11/09/2024
02	Upated volume	LG	MV	MV	03/08/2024
01	Revised as per Custome comments	LG	MV	MV	11/05/2024
00	FIRST ISSUE	LG	MV	MV	03/02/2024

Schema/Scale	1 : 5	Formato/Size	A1
Comm. N°/Job No.	C230048	Foglio/Sheet	1 - 1
Cliente/Customer	Airpack Nederland B.V.		
Ord. No.	17735-VV-900 (SK)		
Dis. N°/Dwg No.	C230048DWG002	Rev.	03

Supports detail

Scale 1 : 3

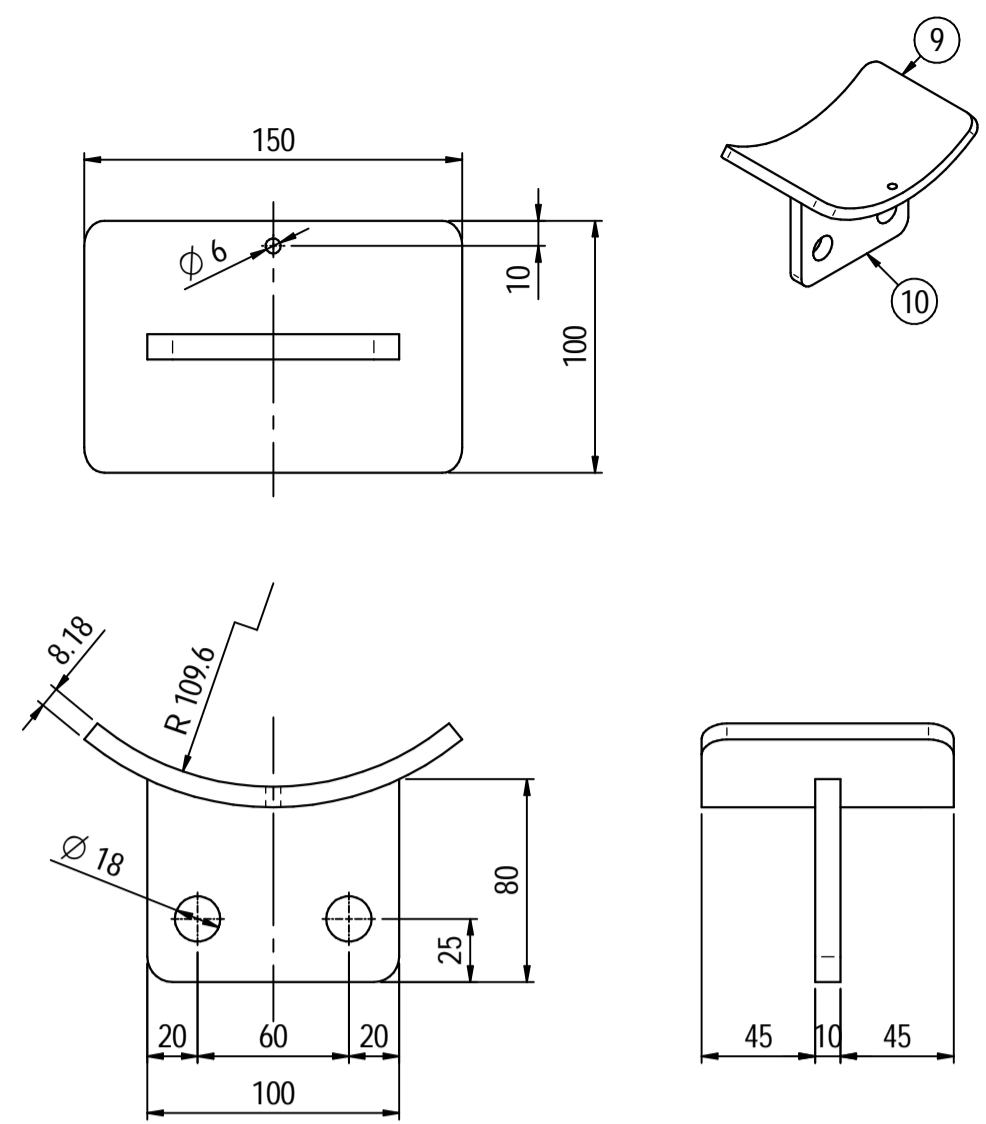

Nameplate detail

Scale 1:5

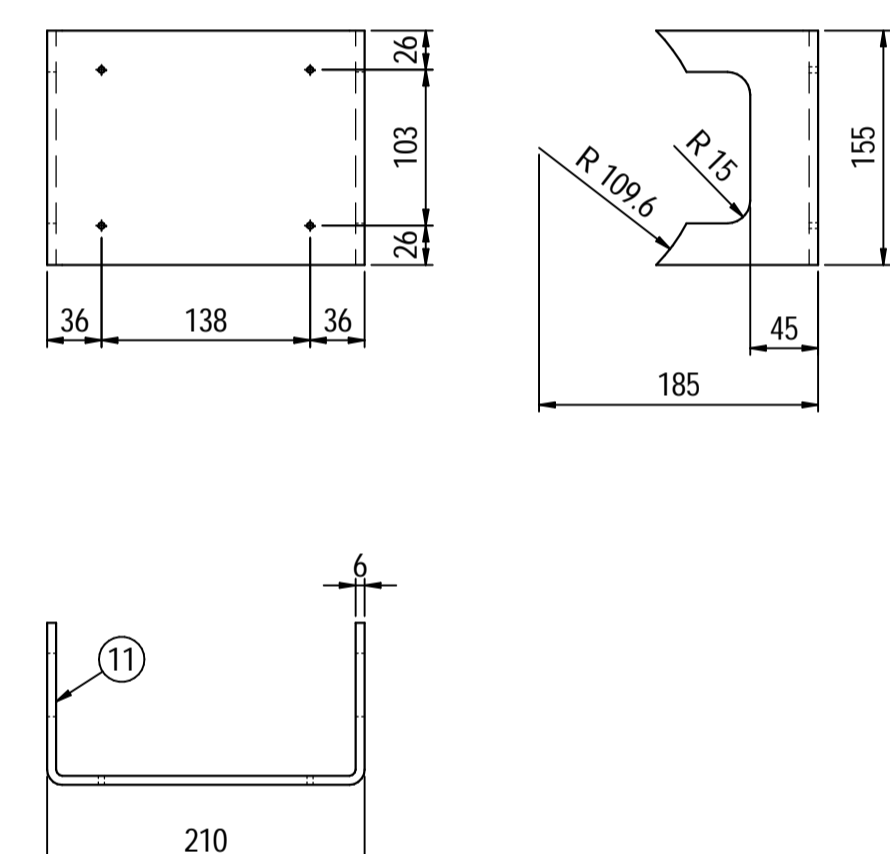

Nameplate detail

scale 1:1.5

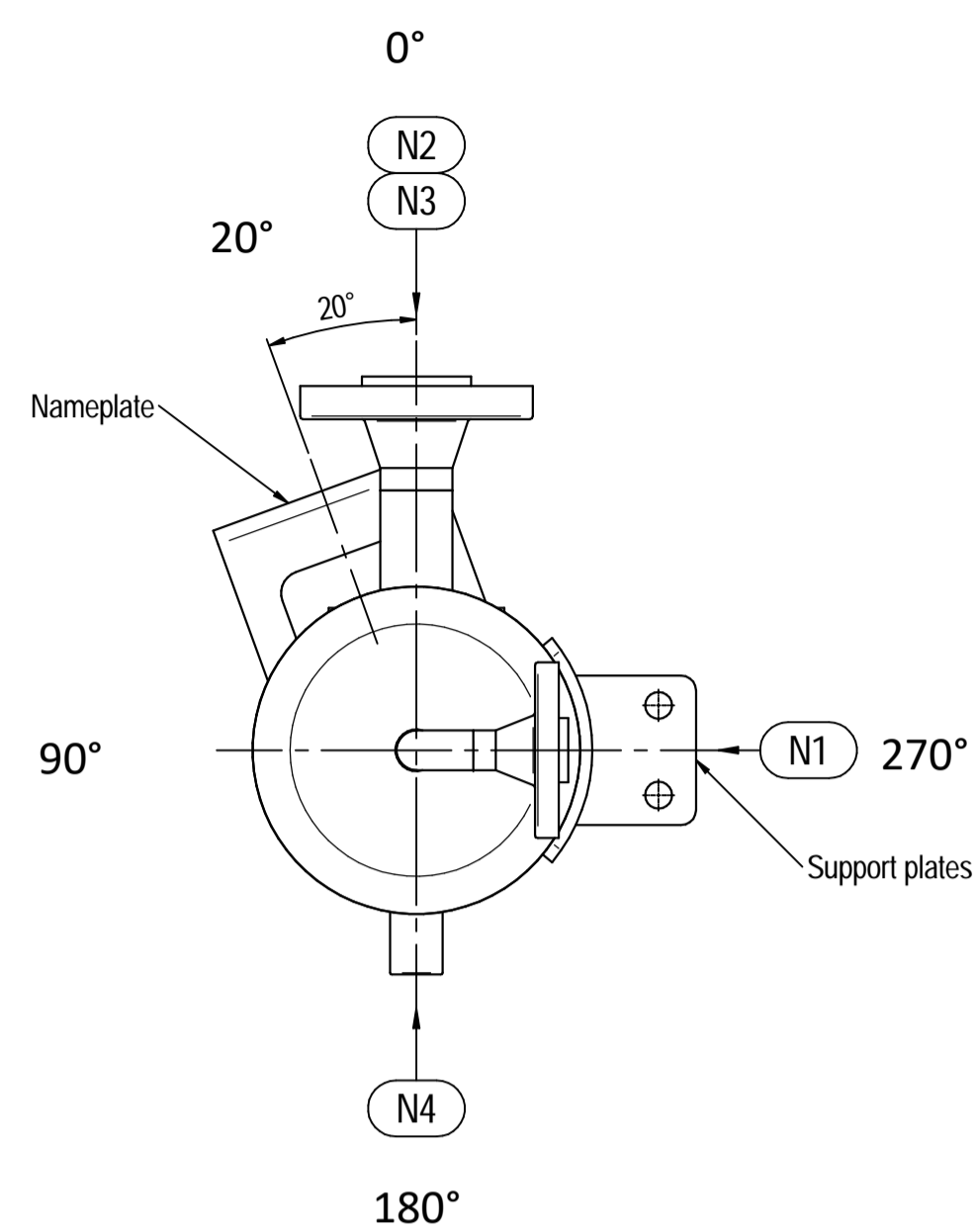
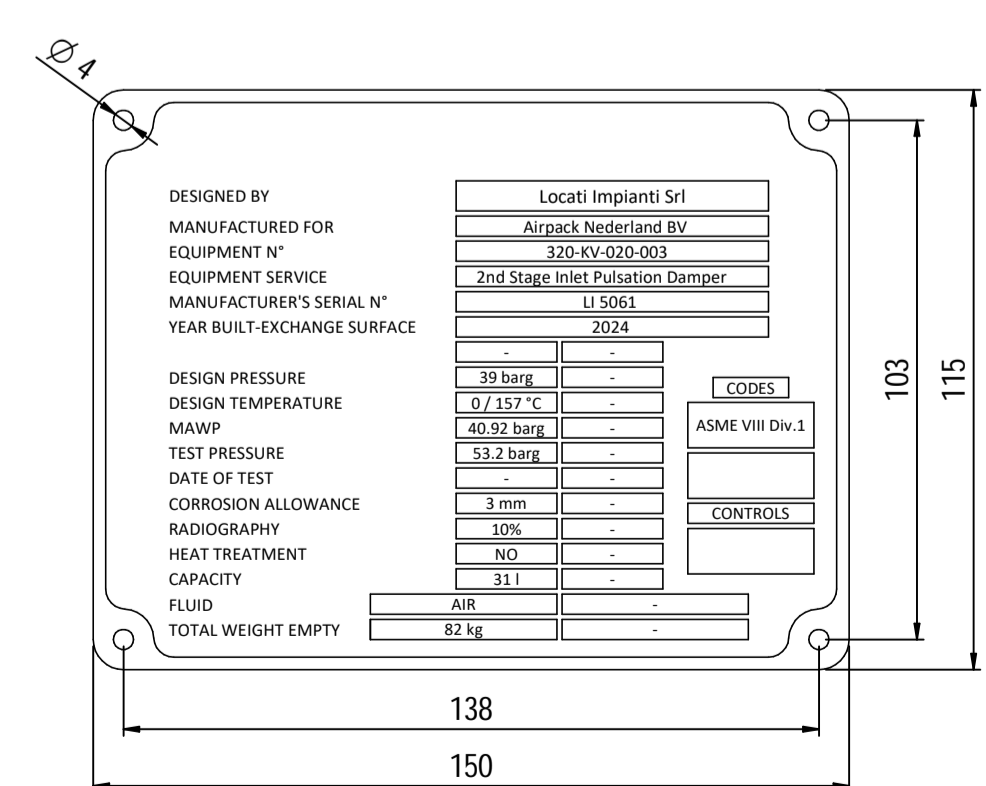

ORIENTATION VIEW

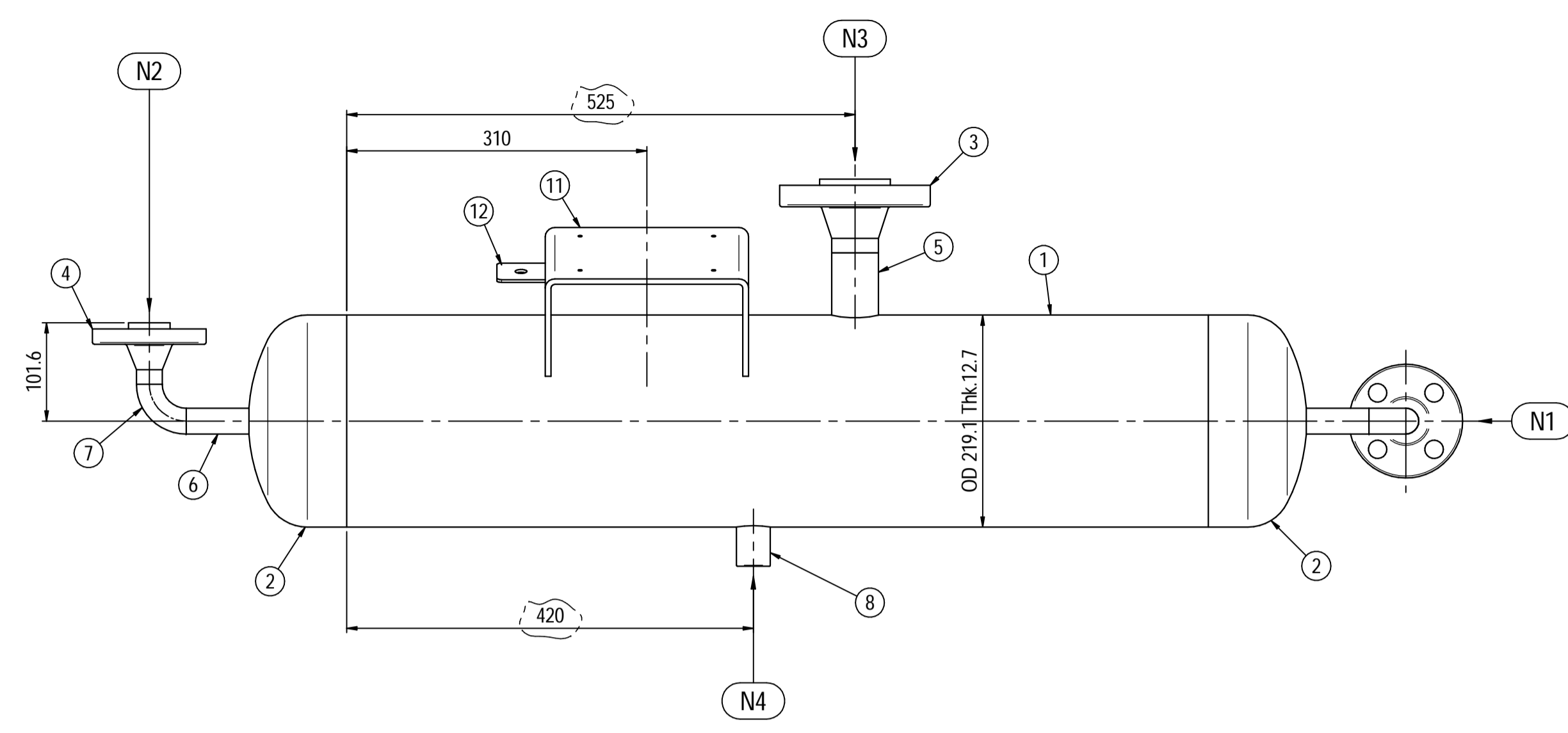

ELEVATION VIEW

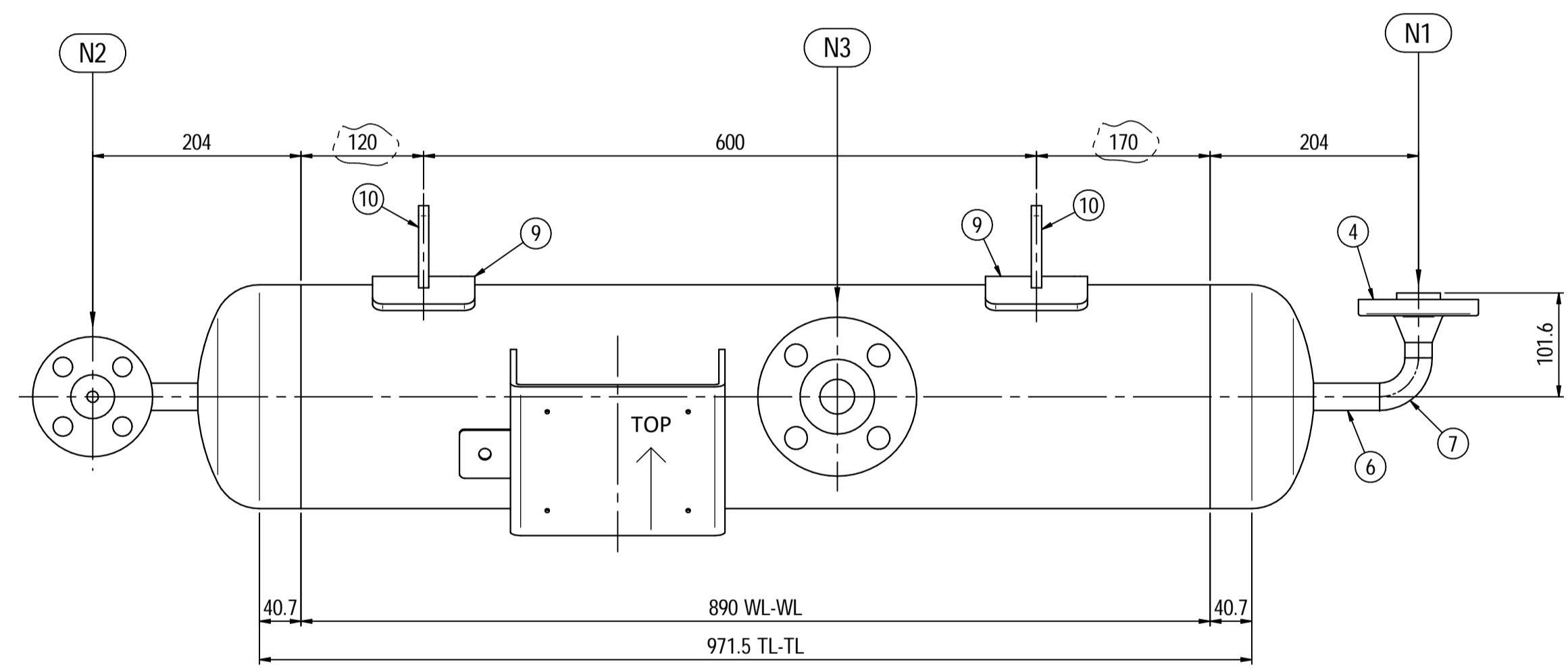

PLAN VIEW

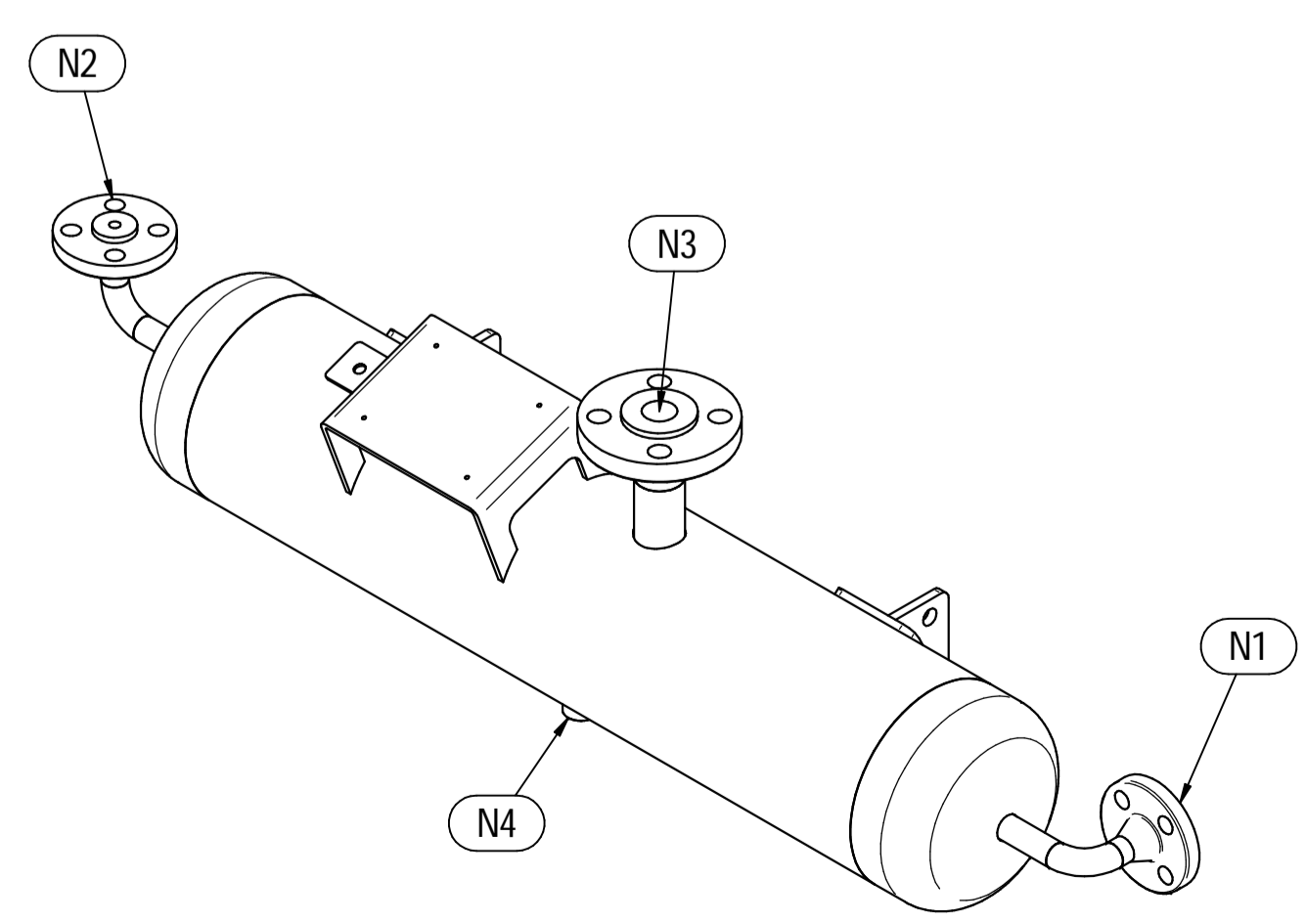

ISOMETRIC VIEW

Pos.	QTY	Description	Material	Cert.
1	1	Shell by Seamless Pipe 8" Sch.80 L=890	SA106 Gr.B	3.1
2	2	Cap 8" Sch80	A234 WPB	3.1
3	1	Flange 1 1/2" WN #600 RF Sch.160	SA105	3.1
4	2	Flange 1/2" WN #600 RF Sch.XXS	SA105	3.1
5	1	Seamless Pipe 1 1/2" Sch.160 L=80	SA106 Gr.B	3.1
6	2	Seamless Pipe 1/2" Sch.XXS L=77	SA106 Gr.B	3.1
7	2	Seamless elbow 1/2" 90° LR Sch.XXS	SA234 WPB	3.1
8	1	Coupling 1/2" NPT #6000	A105	3.1
9	2	Pad by pipe 100 x 150 Thk.8.18	SA106 Gr.B	3.1
10	2	Support plate 100 x 80 Thk.10	SA516 70	
11	1	Nameplate support by plate 403 x 155 Thk.6	SA516 70	
12	1	Earthing plate 50 x 40 Thk.3	SA240 TP316L	

- Note:**
- 1) Governing measurement S.I. unless otherwise specified
 - 2) Flange bolt holes have to be straddled from main vessel center line in plan & vertical & horizontal centreline in elevation
 - 3) Material: certification 3.1 EN 10204
 - 4) All internal edge shall be rounded off
 - 5) Nozzle flanges in accordance with ASME B16.5: 2020
 - 6) Flange fittings in accordance with ASME B16.9: 2018
 - 7) All fillet welds not detailed on "WELDING MAP" or drawing shall have the weld throated equal to 0.7 times the minimum thickness to be welded
 - 8) All welds are continuous except where indicate
 - 9) Delated
 - 10) The nameplate use in SS316 and is laser engraved
 - 11) Non corrosive service, no inspection opening per UG-46(a)
 - 12) On support hexagonal bolts DIN 933, class 8.8 shall be use (Airpack scope)

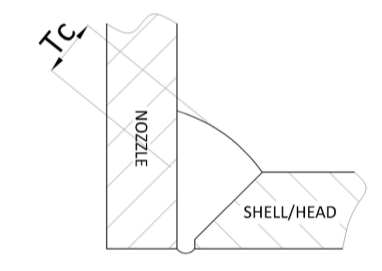

ITEM	QTY	SERVICE	SIZE	O.D.	THK	RATING	TYPE	FACE	O.D.	THK.	Tc
N4	1	DRAIN	1/2"	38.1	8.28	#6000	NPT-F	-	-	-	8 ± 10
N3	1	TEMPERATURE TRANSMITTER	1 1/2"	48.3	7.14	#600	WN RF	-	-	-	8 ± 10
N2	1	AIR OUTLET	1/2"	26.7	7.82	#600	WN RF	-	-	-	8 ± 10
N1	1	AIR INLET	1/2"	26.7	7.82	#600	WN RF	-	-	-	8 ± 10

ITEM	Qtà	SERVIZIO	NPS/DN	O.D.	THK	RATING	TYPE	FACE	O.D.	THK.	RINFORZO
DATI DI PROGETTO / Design data											
FLUIDO		Air									
STATO FISICO DEL FLUIDO		Test									
STATO FISICO DEL FLUIDO		Gas									
CODICE DI CALCOLO		ASME VIII Div. 1 Ed.2021									
PRESSIONE DI ESERCIZIO		22.1 barg									
PRESSIONE DI PROGETTO		39 barg									
PRESSIONE ESTERNA		NO									
PRESSIONE DI PROVA IDRAULICA		53.2 barg									
TEMPERATURA DI ESERCIZIO		60 °C									
TEMPERATURA DI PROGETTO		157 °C									
SOVRAMEZZO DI CORROSIONE		3 mm									
CAPACITA'		31 l									
EFFICIENZA GIUNTI		0.85									
MAWP @ Design Temperature		40.92 barg @ +157 °C									
MDMT @ MAWP		0 °C @ 40.92 barg									
IMPACT TEST		NO									

Rev.	Descrizione / Description	Disegnato/Draw	Controllato/Checked	Approvato/Approved	Data/Date
04	Issue for approval	LG	MV	MV	04/10/2024
03	Issue for approval	LG	MV	MV	01/10/2024
02	Issue for approval	LG	MV	MV	11/09/2024
01	Revised as per Customer comments	LG	MV	MV	11/05/2024
00	FIRST ISSUE	LG	MV	MV	03/02/2024

Objetto/Object: **2nd STAGE INLET PULSATION DAMPER**

Scala/Scale	1 : 5	Formato/Size	A1
Comm. N°/Job No.	C230048	Foglio/Sheet	1 - 1
Cliente/Customer	Airpack Nederland B.V.		
Ord. No.	17735-VV-900 (SK)		
Dis. N°/Dwg No.	C230048DWG003	Rev.	04

Supports detail
Scale 1 : 3

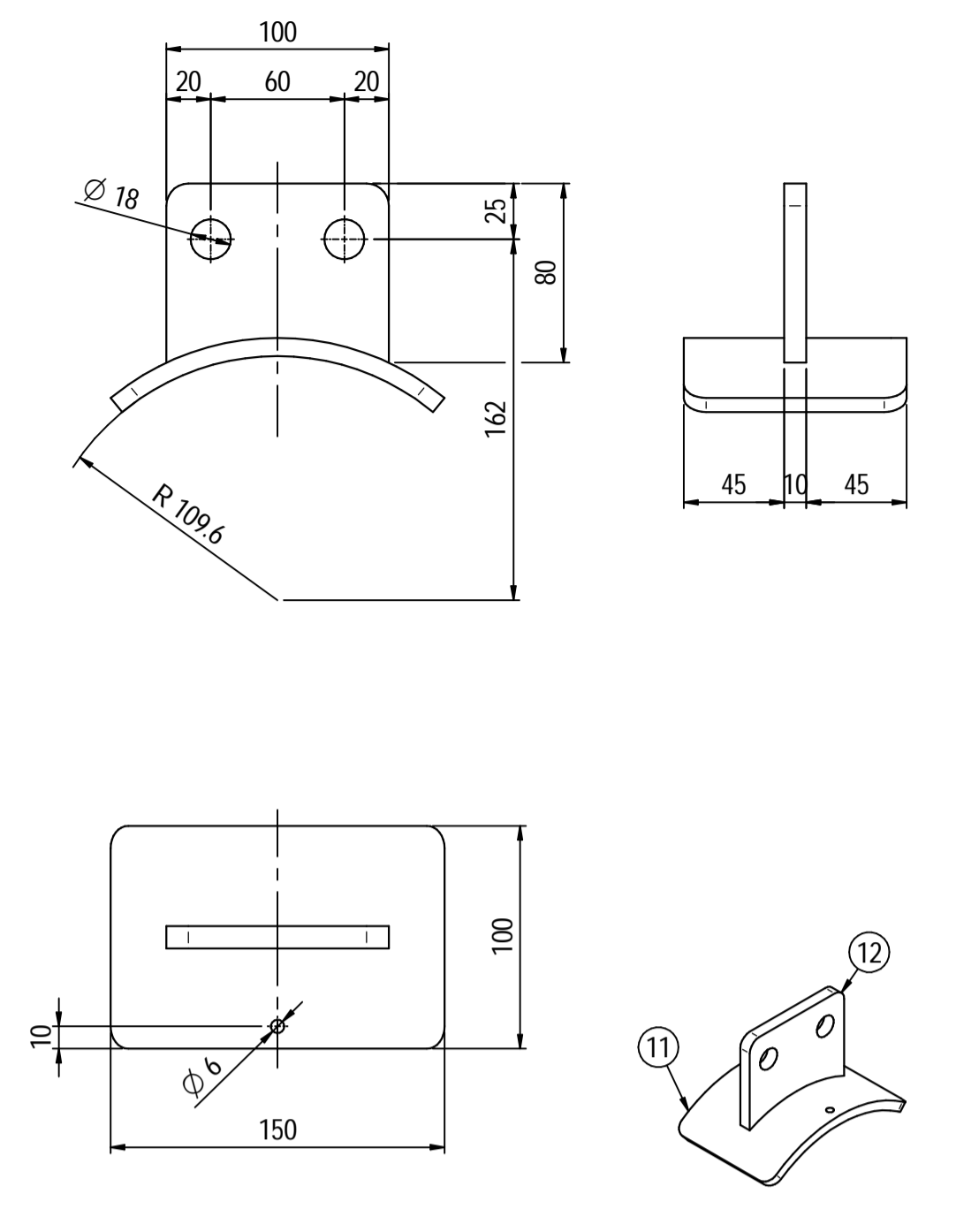

Nameplate detail
Scale 1:5

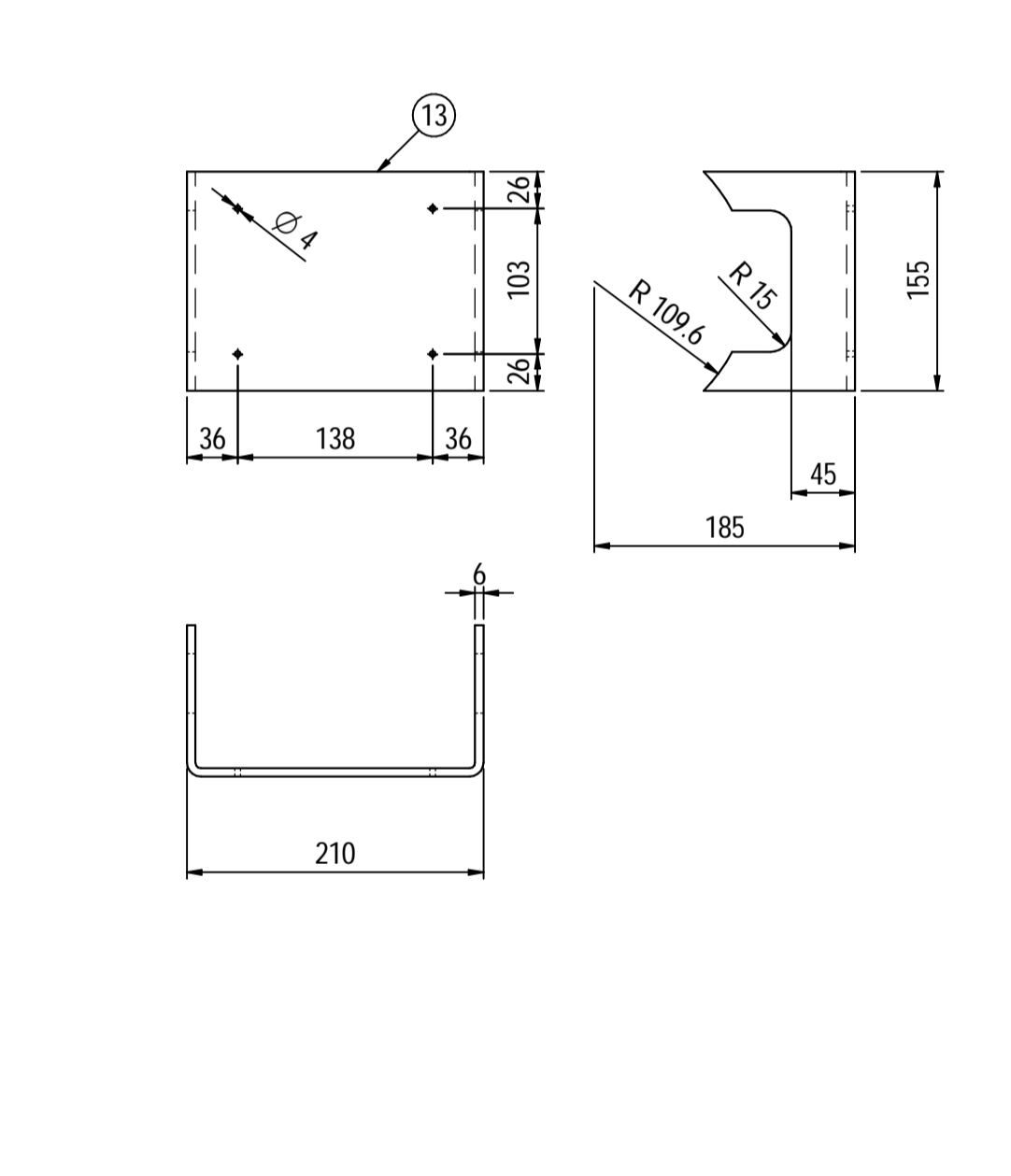

Nameplate detail
scale 1:1.5

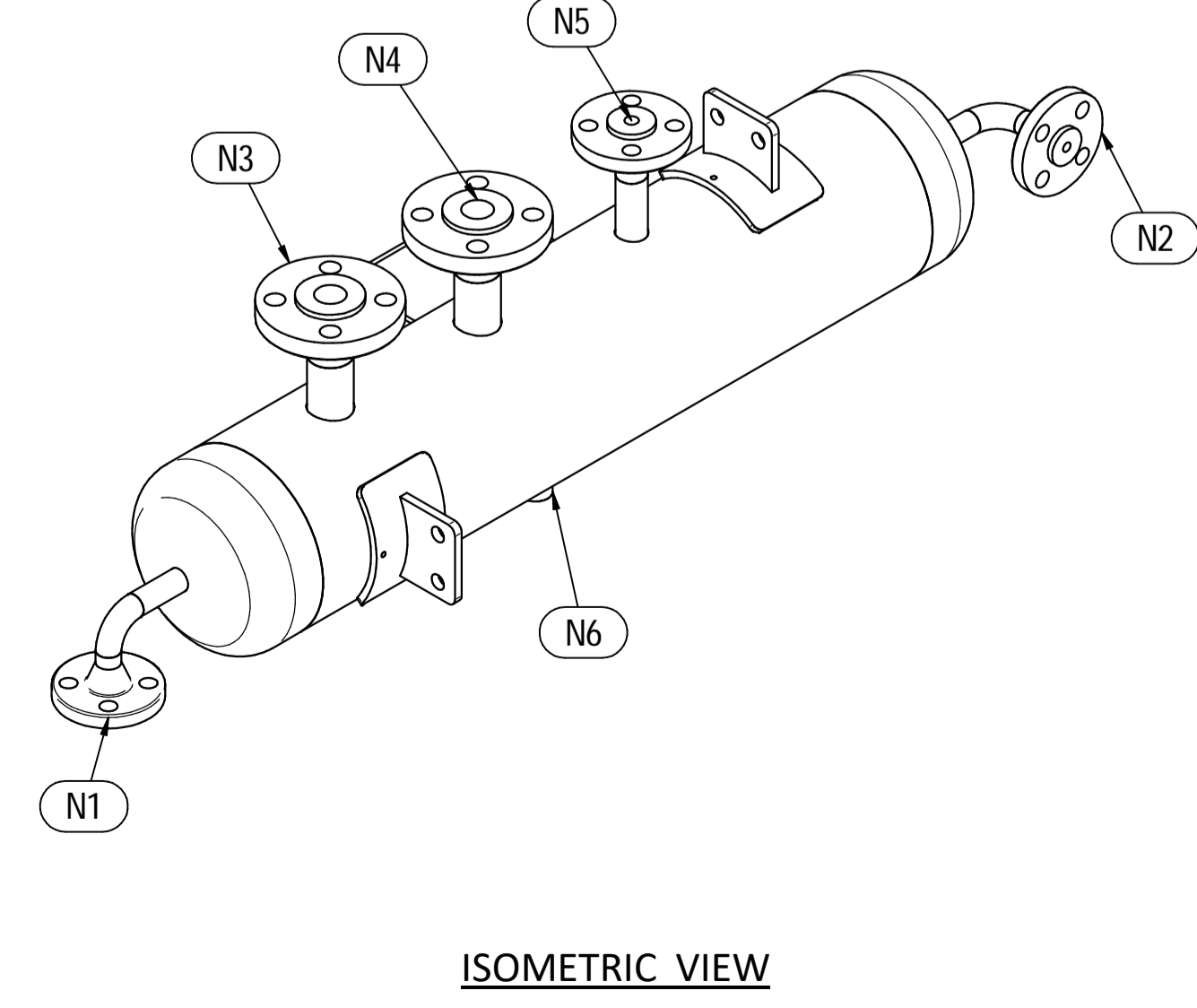
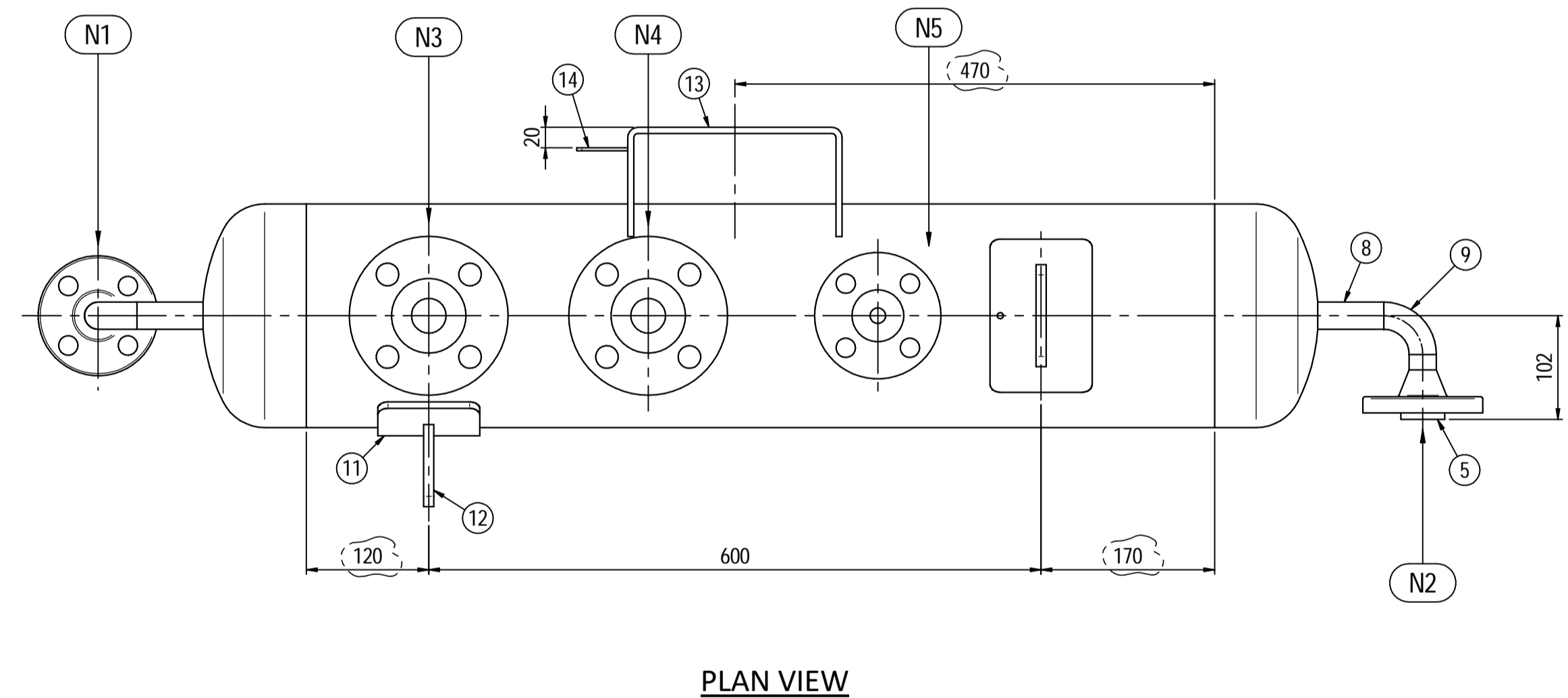
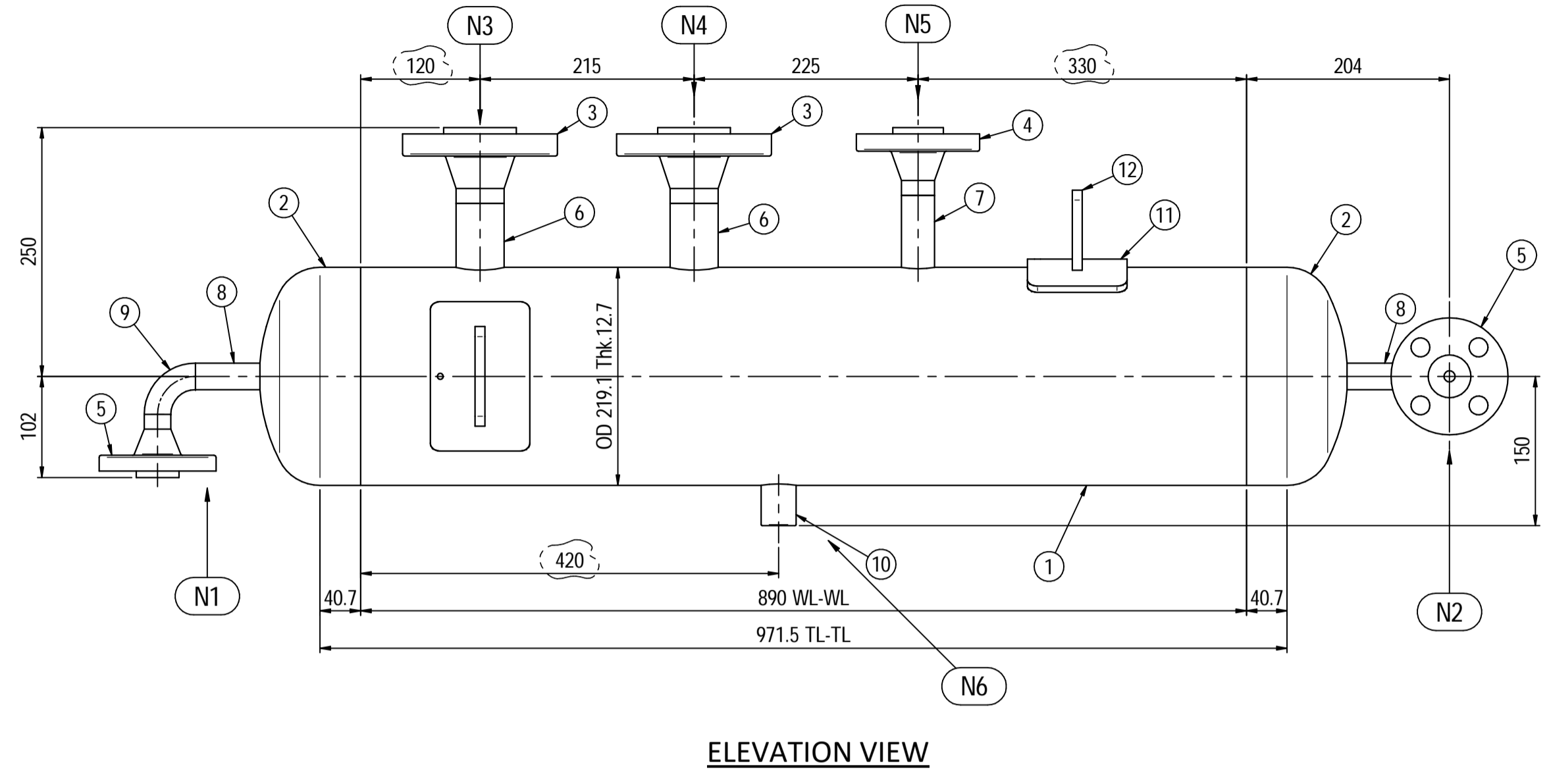
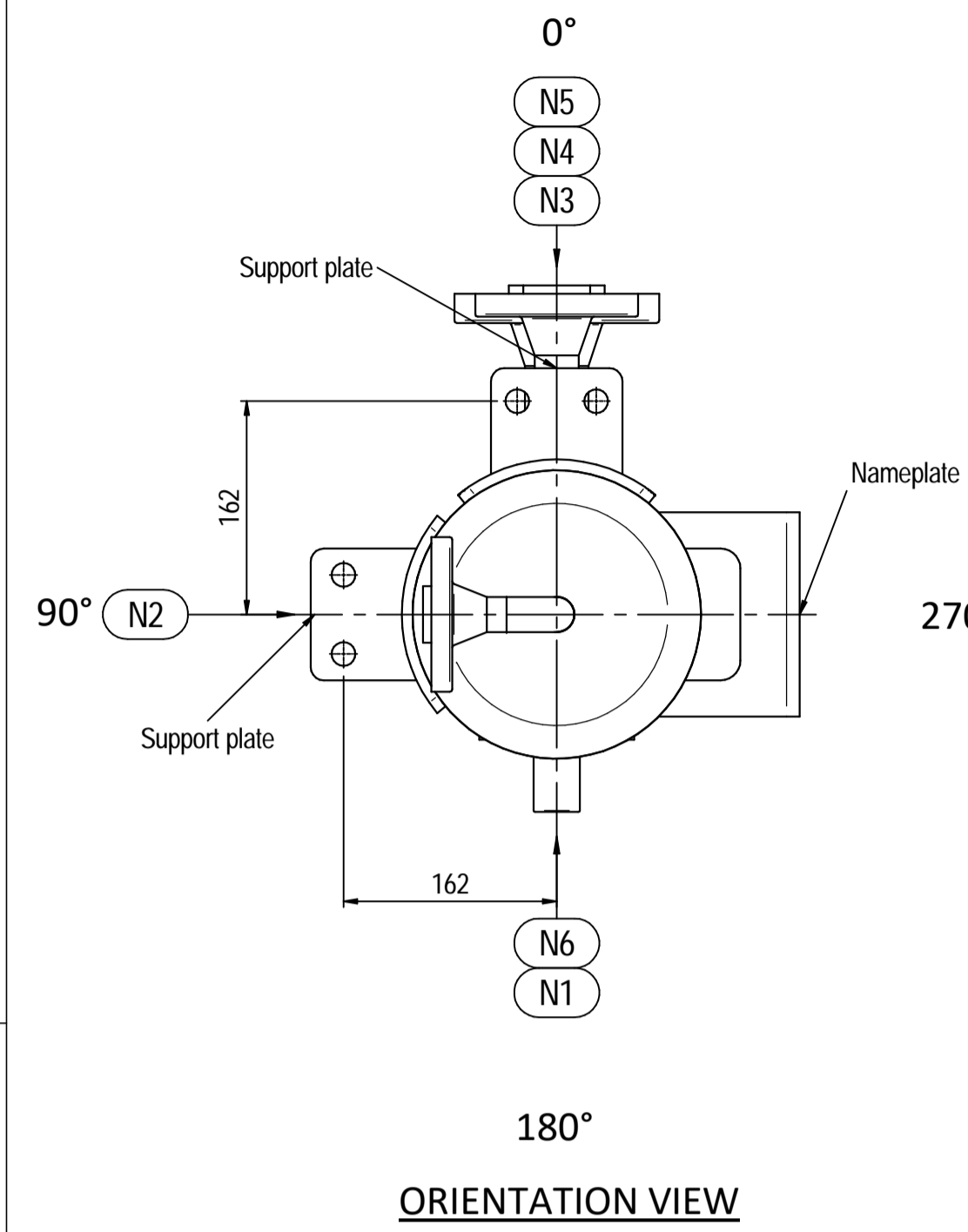
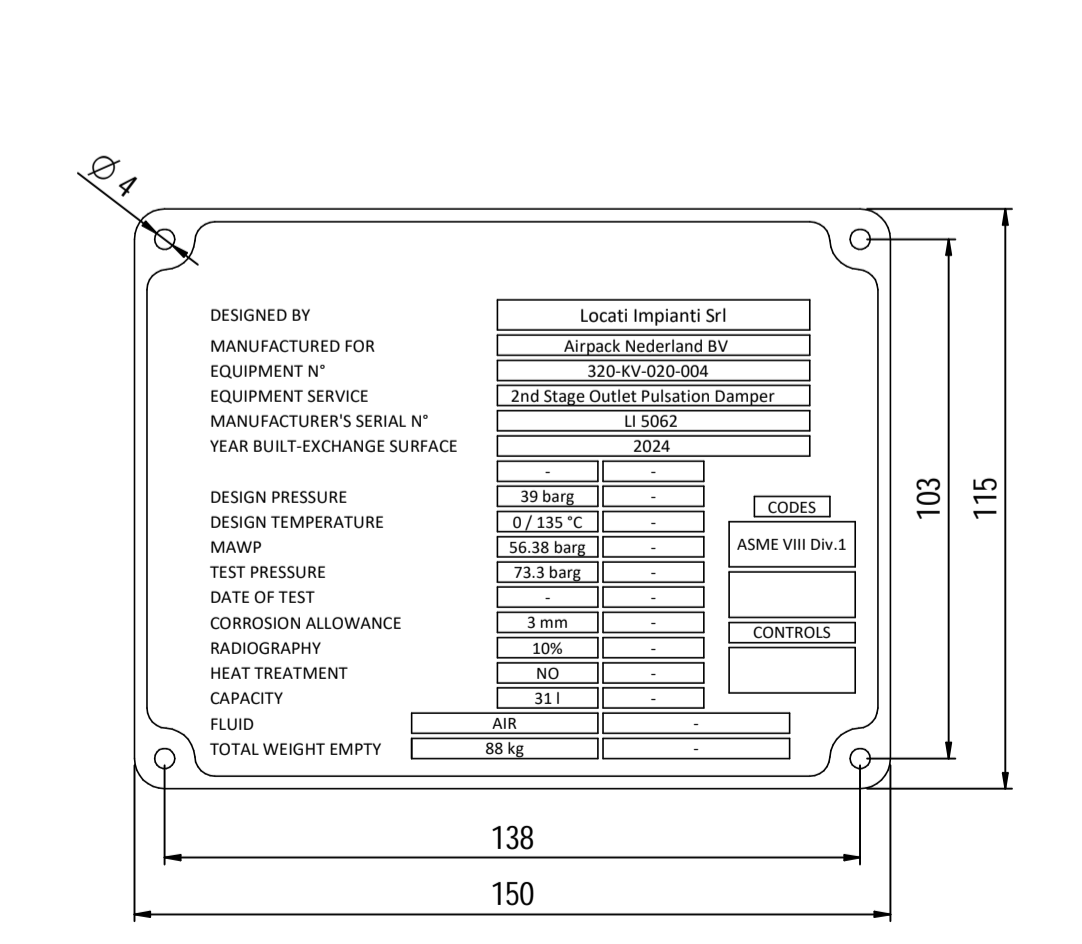

Pos.	QTY	Description	Material	Cert.
1	1	Shell by Seamless Pipe 8" Sch.80 L=890	SA106 Gr.B	3.1
2	2	Cap 8" Sch80	A234 WPB	3.1
3	2	Flange 1 1/2" WN #600 RF Sch.160	SA105	3.1
4	1	Flange 1" WN #600 RF Sch.XXS	SA105	3.1
5	2	Flange 3/4" WN #600 RF Sch.XXS	SA105	3.1
6	2	Seamless Pipe 1 1/2" Sch.160 L=80	SA106 Gr.B	3.1
7	1	Seamless Pipe 1" Sch.XXS L=80	SA106 Gr.B	3.1
8	2	Seamless Pipe 3/4" Sch.XXS L=77	SA106 Gr.B	3.1
9	2	Seamless elbow 3/4" 90° LR Sch.XXS	SA234 WPB	3.1
10	1	Coupling 1/2" NPT #6000	A105	3.1
11	2	Pad by pipe 100 x 150 Thk.8.18	SA106 Gr.B	3.1
12	2	Support plate 100 x 80 Thk.10	SA516 70	
13	1	Nameplate support by plate 403 x 155 Thk.6	SA516 70	
14	1	Earthing plate 50 x 40 Thk.3	SA240 TP316L	

- Note:**
- Governing measurement S.I. unless otherwise specified
 - Flange bolt holes have to be straddled from main vessel center line in plan & vertical & horizontal centreline in elevation
 - Material: certification 3.1 EN 10204
 - All internal edge shall be rounded off
 - Nozzle flanges in accordance with ASME B16.5: 2020
 - Flange fittings in accordance with ASME B16.9: 2018
 - All fillet welds not detailed on "WELDING MAP" or drawing shall have the weld throated equal to 0.7 times the minimum thickness to be welded
 - All welds are continuous except where indicate
 - Delated
 - The nameplate is in SS316 and is laser engraved
 - Non corrosive service, no inspection opening per UG-46(a)
 - On support hexagonal bolts DIN 933, class 8.8 shall be use (Airpack scope)

ITEM	QTY	SERVICE	SIZE	O.D.	THK	RATING	TYPE	FACE	O.D.	THK.	Tc
N6	1	DRAIN	1/2"	38.1	8.38	#6000	NPT-F	-	-	-	8 ± 10
N5	1	PSV CONNECTION	1"	33.4	9.09	#600	WN RF	-	-	-	8 ± 10
N4	1	TEMPERATURE TRANSMITTER	1 1/2"	48.3	7.14	#600	WN RF	-	-	-	8 ± 10
N3	1	TEMPERATURE GAUGE	1 1/2"	48.3	7.14	#600	WN RF	-	-	-	8 ± 10
N2	1	AIR OUTLET	3/4"	26.7	7.82	#600	WN RF	-	-	-	8 ± 10
N1	1	AIR INLET	3/4"	26.7	7.82	#600	WN RF	-	-	-	8 ± 10

ITEM	Qtà	SERVIZIO	NPS/DN	PIPE TUBO	THK	RATING	FLANGE TYPE	FACE	O.D.	THK.	PAD RINFORZO
DATI DI PROGETTO / Design data											
FLUIDO		Air					COLLAUDO				0094 Iqqa Inspection Iberia SA
STATO FISICO DEL FLUIDO		Gas					Test				N/A
CODICE DI CALCOLO							ASME VIII Div. 1 Ed.2021				
PRESSIONE DI ESERCIZIO		30 barg					SERVIZIO LETALE				NO
PRESSIONE DI PROGETTO		39 barg					X-RAY				Spot (10%)
PRESSIONE ESTERNA		NO					LICUIDI PENETRANTI				NO
PRESSIONE DI PROVA IDRAULICA		73.3 barg					ULTRASUONI				NO
TEMPERATURA DI ESERCIZIO		116°C					CONTROLLO MAGNETOSCOPICO				NO
TEMPERATURA DI PROGETTO		135°C					TALLONE DI SALDATURA				NO
SOVRAMEZZO DI CORROSIONE		3 mm					PROCEDIMENTO DI SALDATURA				See doc: C230048WBK009
CAPACITA'		311					TIPO DI FONDO				CAP
EFFICIENZA GIUNTI		0.85					FORMATURA FONDO				HOT
MAMP @ Design Temperature		56.38 barg @ +135°C					PESO A VUOTO				88 kg
MAMP(EXT)		NO					PESO IN ESERCIZIO				88 kg
MDMT @ MAMP		0 °C @ 56.38 barg					PESO PIENO D'ACQUA				119 kg
TRATTAMENTO TERMICO		NO					DATI DEL VENTO				
IMPACT TEST		NO					DATI SISMICI				

Rev.	Descrizione / Description	Disegnato/Draw	Controllato/Checked	Approvato/Approved	Data/Date
05	Issue for approval	LG	MV	MV	04/10/2024
04	Issue for approval	LG	MV	MV	01/10/2024
03	Issue for approval	LG	MV	MV	11/09/2024
02	Change position of N2 nozzle	LG	MV	MV	11/07/2024
01	Revised as per Customer comments	LG	MV	MV	11/05/2024
00	FIRST ISSUE	LG	MV	MV	03/02/2024