



 Gachsaran Polymer Industries Company PIDMCO	Gachsaran Polymer Industries Company HDPE Plant			
	Instrument Datasheet & Catalogs For Refrigeration Unit Package		 	
PO No.: GPIC-PT-MA-PO-000-3029	Document Number: VD-GPIC-MA-3029-3029- 0038	Rev. 00	Page 1 of 28	

Instrument Datasheet & Catalogs For Refrigeration Unit Package

Code1	<input type="checkbox"/> No Comment/ Approved (Applicable Only for "FOR REVIEW" and "For Approval" Documents) No comment and the document are released for Manufacturing.
Code2	<input type="checkbox"/> No Comment/ Approved with Note(s) Vendor/Sub-Contractor shall correct, revise and resubmit the document. The document is released for Manufacturing if changes incorporated.
Code3	<input checked="" type="checkbox"/> Commented Vendor/Sub-Contractor shall correct, revise and resubmit the document by the date specified. The document shall be revised under the Status of "R: Revised Issue". All corrected documents shall be resubmitted before starting the Manufacturing Process.
Code 4	<input type="checkbox"/> Not Accepted (Rejected) Vendor/Sub-Contractor shall re-work / re-design / re-specify the contents of the document according to the comments / reasons for rejection. All corrected documents shall be resubmitted before starting the manufacturing. Vendor/Sub-Contractor shall not proceed with subsequent works of Material Supply or Manufacturing until receiving Code1/Code2 or No Code from PURCHASER. Vendor/Sub-Contractor shall resubmit the document with the same revision within 6 working days after receiving comments.
No code	<input type="checkbox"/> No Code (Applicable Only for "For Information" Documents and "As Built DWGs") Document has been submitted for PURCHASER's Information (FI). Consistency, completeness and correctness of document content is in Vendor/Sub-Contractor's responsibility.
Above checking results by EIED shall in no way relieve Vendor of any liability, obligation and responsibility out of the purchase order and the mutual agreement in writing.	
 Energy Industries Engineering & Design co.	Date: Nov. 03, 2025 Dept.: MA Signature: F.Hamooni

05					
04					
03					
02					
01					
00	12-Oct-25	IFR	N.B	F.T	A.M
Rev.	DATE	PURPOSE OF ISSUE	PREPARED	CHECKED	APPROVED

				PRESSURE GAUGE		Document No: VD-GPIC-MA-3029-3029-0038-00	
						Document Title: Instrument Data sheet & Catalogs	
		NO.	BY	APP	DATE	P.O.I.	
		00	N.B	A.M	12.10.25	IFR	
CLIENT: Gachsaran Polymer Industries Company (GPIC) P.O. NO.: GPIC-PT-MA-PO-000-3029 SERVICE: PROPYLENE REFERIGERATION PACKAGE							
IN-01. 150mm							
1. Type: Direct Reading <input checked="" type="checkbox"/> 3-15 lb Receiver <input type="checkbox"/> Other <input type="checkbox"/> 2. Mounting: Surface <input type="checkbox"/> Local <input checked="" type="checkbox"/> Flush <input type="checkbox"/> 3. Dial: Diameter 4 1/2" <input checked="" type="checkbox"/> Color: WHITE			10. Mfr & Model No. SEE LIST BELOW 11. Pressure Element: Bourdon <input checked="" type="checkbox"/> Bellows <input type="checkbox"/> Other <input type="checkbox"/> 12. Bourdon Mat'l: Bronze <input type="checkbox"/> Steel <input type="checkbox"/> 316SS <input checked="" type="checkbox"/> Other <input type="checkbox"/> 13. Socket Mat'l: Bronze <input type="checkbox"/> Steel <input type="checkbox"/> 316SS <input checked="" type="checkbox"/> Other <input type="checkbox"/> 14. MNPT Conn.: 1/4" <input type="checkbox"/> 1/2" <input checked="" type="checkbox"/> Other <input type="checkbox"/> Bottom <input checked="" type="checkbox"/> Back <input type="checkbox"/> 15. Movement Mat'l: Bronze <input type="checkbox"/> 316SS <input checked="" type="checkbox"/> Nylon <input type="checkbox"/> Other <input type="checkbox"/> 16. Diaphragm Seal <input type="checkbox"/> NOT REQUIRED MFG Type Wetted Part Mtl. Other Mat'l Fill Fluid Process Conn. Gage Conn.				
4. Case: Cast Iron <input type="checkbox"/> Aluminum <input type="checkbox"/> Phenolic <input type="checkbox"/> Stainless Steel <input checked="" type="checkbox"/> Other <input type="checkbox"/> 5. Ring: Screwed <input checked="" type="checkbox"/> Hinged <input type="checkbox"/> Slip <input type="checkbox"/> Std <input type="checkbox"/> Other <input type="checkbox"/> 6. Blow-out Protection: None <input type="checkbox"/> Back <input checked="" type="checkbox"/> Disc <input type="checkbox"/> Solid Front <input type="checkbox"/> Other <input type="checkbox"/> 7. Lens: Glass <input checked="" type="checkbox"/> SAFETY GLASS FRONT Plastic <input type="checkbox"/> 8. Option: Syphon <input type="checkbox"/> Material: NONE Snubber <input type="checkbox"/> Material: NONE Pressure Limit Valve <input type="checkbox"/> Movement Damping <input checked="" type="checkbox"/> GLYCERINE FILLED							
9. Nominal Accuracy Required: +/- 1%							
Item	Qty.	Tag No.	Range PSIG BAR	Oper. Pressure PSIG (BarG)		Service	MANUFACTURER Model NO.
				OPER.	MAX.		
A	1	PG-61131	0 to 500	336	351	PROPYLENE GAS	
		PUMP DISCHARGE	0 to 34	23.2	24.2	& SYNTHETIC OIL	
B	1	PG-61132	0 to 500	336	351	PROPYLENE GAS	
		PUMP DISCHARGE	0 to 34	23.2	24.2	& SYNTHETIC OIL	
C	1	PG-61141	0 to 500	270	351	PROPYLENE GAS	
		RECEIVER	0 to 34	18.6	24.2	& SYNTHETIC OIL	
D							
E							
F							
G							
H							
I							
J							
K							
L							

IN-02. 0-40 Barg

Notes:

- SYSTEM DESIGN PRESSURE & TEMPERATURE:

FV to	362.5 PSIG	25.0 BarG	@	250 °F	121 °C	FOR ITEMS:	3
				-45 °F	-43 °C		
FV to	406 PSIG	28.0 BarG	@	250 °F	121 °C	FOR ITEMS:	1, 2
				-20 °F	-29 °C		
- WETTED MATERIAL IS 316 STAINLESS STEEL
- INSTRUMENT SHALL BE SUITABLE FOR MARINE, SALT LADEN, CORROSIVE ENVIRONMENT
- CALIBRATION CERTIFICATE REQUIRED NOT REQUIRED
- CERTIFICATE OF COMPLIANCE REQUIRED NOT REQUIRED
- CUSTOMER SPECIFICATION: N/A & N/A
- OVERPRESSURE PROTECTION IS REQUIRED
- MATERIAL SHALL BE PER APPROVED VENDOR LIST. DEVIATION FROM "AVL" IS NOT ALLOWED.
- ALL DOCUMENTS TO BE SUBMITTED IN BOTH HARD AND ELECTRONIC FORMAT
- GAUGE OPERATING TEMPERATURE RATING OF 100 C IS ACCEPTBLE AS THE OIL SYSTEM WILL NOT REACG 100C.
- INGRESS PROTECTION: IP65



IN-03. 2 valve manifold shall be supplied for all PG

CLIENT: Gachsaran Polymer Industries Company (GPIC)
 P.O. NO.: GPIC-PT-MA-PO-000-3029
 SERVICE: PROPYLENE REFERIGERATION PACKAGE

GENERAL	1	Tag No.	SEE TABLE BELOW	Service: See Table Below
	2	Qty		
	3	Function	Record <input type="checkbox"/> Indicate <input checked="" type="checkbox"/> Control <input checked="" type="checkbox"/> VIA MCS Blind <input type="checkbox"/> Trans <input checked="" type="checkbox"/> Other	
	4	Case	Mfr. Std. <input checked="" type="checkbox"/> Nom. Size	IN-04. add "EExia" per NOTE 2
	5	Mounting	Flush <input type="checkbox"/> Surface	
	6	Enclosure Class	Gen. Purpose <input type="checkbox"/> Weather Proof <input type="checkbox"/> Explosion Proof <input type="checkbox"/> Use in intrinsically <input checked="" type="checkbox"/> Safe System <input type="checkbox"/> Other <input checked="" type="checkbox"/> IIB-T5 - ZONE 1, CL1	
	7	Power Supply	117V 60 Hz <input type="checkbox"/> Other ac <input type="checkbox"/> DC <input checked="" type="checkbox"/> Volts 24 V	
	8	Chart	N/A Strip <input type="checkbox"/> Roll <input type="checkbox"/> Fold <input type="checkbox"/> Time Mark: <input type="checkbox"/>	IN-05. It shall be selected.
	9	Chart Drive	N/A Speed	
	10	Scales	Type: LCD / DIGITAL (UNITS per Note) Range: SEE TABLE BELOW	
XMTR	11	Transmitter Output	4-20 mA <input type="checkbox"/> NOTE 9 10-50mA <input type="checkbox"/> 21-103 kPa (3-15 psig) <input type="checkbox"/> Other For Receiver, see spec sheet. WIRED TO UCP VIA JUNCTION BOXES (2 WIRE OUTPUT) NOTE 9	
CONTROLLER VIA UCP	12	Control Modes	P = Prop (Gain), I = Integral (Auto Reset), D = Derivative (Rate) Sub: s = slow, f = fast, if <input type="checkbox"/> Df <input type="checkbox"/> P <input checked="" type="checkbox"/> PID <input type="checkbox"/> PD <input type="checkbox"/> PI <input type="checkbox"/> Is <input type="checkbox"/> Ds <input type="checkbox"/> Other	
	14	Action	On Measurement Increase, Output: Increases <input type="checkbox"/> Decreases <input type="checkbox"/>	
	15	Auto-Man Switch	None <input type="checkbox"/> MFR Std <input type="checkbox"/> Other <input checked="" type="checkbox"/> NOTE 21	
	16	Set Point Adj.	Manual <input type="checkbox"/> External <input type="checkbox"/> Remote <input checked="" type="checkbox"/> UCP Other NOTE 9	
	17	Manual Reg.	None <input type="checkbox"/> MFR Std <input type="checkbox"/> Other	
	18	Output	4-20 mA <input type="checkbox"/> NOTE 9 10-50 mA <input type="checkbox"/> 21-103 kPa (3-15 psig) <input type="checkbox"/> Other	
	19	Service	Gage Press <input checked="" type="checkbox"/> Vacuum <input type="checkbox"/> Absolute <input type="checkbox"/> Compound <input type="checkbox"/>	
	20	Element Type	Diaphragm <input type="checkbox"/> Helix <input type="checkbox"/> Bourdon <input type="checkbox"/> Bellows <input type="checkbox"/> Other NOTE 19	
ELEMENT	21	Material (body)	316SS <input checked="" type="checkbox"/> Ber Copper <input type="checkbox"/> Other <input type="checkbox"/>	
	22	Range	Fixed <input type="checkbox"/> Adj. Range <input checked="" type="checkbox"/>	
	23	Process Data	Overrange Protection to: SEE TABLE BELOW Press.: Nor.: SEE TABLE BELOW MAX.: Element Range:	
	24	Process Conn.	1/4" in NPT <input type="checkbox"/> 1/2" in NPT (F) <input checked="" type="checkbox"/> Other: 1/2" CONDUIT CONNECTION Location: Bottom: <input checked="" type="checkbox"/> Back <input type="checkbox"/> Other	
	25	Alarm Switches	Quantity: BY UCP REFER TO SETPOINT LIST Form Rating	
	26	Function	Press. <input checked="" type="checkbox"/> Deviation <input type="checkbox"/> Contacts On Incr. Meas. Filter Reg. <input type="checkbox"/> Sup. Gage <input type="checkbox"/> Output Gage <input type="checkbox"/> Charts	
OPTIONS VIA UCP	27	Options	Diaphragm Seal <input type="checkbox"/> Type N/A IN-06. "EExia" Bowl Conn. Capillar: N/A Other ELECTRICAL GROUND SCREW REQUIRED	
	AREA CLASSIFICATION		IEC <input checked="" type="checkbox"/> ZONE 1, EExi IIB-IP-67 / NEMA4X Agency Approval: ATEX	

Item	Qty	Tag No.	Pressure PSIG - BarG		Op. P. Min	Op. P. Max	Op. P. Range	Op. P. Accuracy	(Note 16)	Service
			Range	Over						
A	1	PIT 61111	-14.7 to 580	1160	22.5	25.9	0.00	250		PROPYLENE &
		SUCTION	-1.01 to 40.0	80.0	1.55	1.76	0.0	17.2	IN-08. 0-5 Barg	
B	1	PIT 61113	-14.7 to 580	1160	304.6	343.3	0.00	400		PROPYLENE &
		OIL SUPPLY	-1.01 to 40.0	80.0	21.0	23.7	0.0	27.6	IN-09. 0-40 Barg	
C										
D										
AA	1	PIT 61121	-14.7 to 580	1160	22.5	25.9	0.00	250		PROPYLENE &
		SUCTION	-1.01 to 40.0	80.0	1.55	1.76	0.0	17.2	IN-10. 0-5 Barg	
BB	1	PIT 61123	-14.7 to 580	1160	304.6	256.1	0.00	400		PROPYLENE &
		OIL SUPPLY	-1.01 to 40.0	80.0	21.0	17.7	0.0	27.6	IN-11. 0-40 Barg	
CC	1									
DD	1	PIT 61141	-14.7 to 580	1160	85.5	289.1	0.00	400		PROPYLENE &
		ECONOMIZER	-1.01 to 40.0	80.0	5.90	19.9	0.0	27.6	IN-12. 0-40 Barg	

IN-13. "PT"

	PRESSURE TRANSMITTER CONTROL DEVICES				Document No: VD-GPIC-MA-3029-3029-0038-00
					Document Title: Instrument Data sheet & Catalogs
	NO.	BY	APP	DATE	P.O.I.
	00	N.B	A.M	12.10.25	IFR
CLIENT: Gachsaran Polymer Industries Company (GPIC)					
P.O. NO.: GPIC-PT-MA-PO-000-3029					
SERVICE: PROPYLENE REFERIGERATION PACKAGE					

Notes:

- 1 SYSTEM DESIGN PRESSURE & TEMPERATURE:

FV to 362.5 PSIG	25.0 BarG	@	250 °F	121 °C	FOR ITEMS: 1, 2
			-45 °F	-43 °C	
FV to 406 PSIG	28.0 BarG	@	250 °F	121 °C	FOR ITEMS: 3
			-20 °F	-29 °C	
- 2 TRANSMITTER ELECTRICAL HOUSING MUST BE POLYURETHANE COVERED ALUMINUM
- 3 REFERENCE ACCURACY: ± 0.1 % OF FULL SCALE & ± 0.15 % GUARANTEED STABILITY OVER FIVE YEARS
- 4 INSTRUMENT SHALL BE SUITABLE FOR **IN-14. "EExia"** ENVIRONMENT
- 5 CALIBRATION CERTIFICATE REQUIRED NOT REQUIRED
- 6 HARD COPY OF IEC-79, EExi IIB-T5 CERTIFICATE REQUIRED NOT REQUIRED
- 7 CUSTOMER SPECIFICATION: N/A, N/A & N/A
- 8 ELECTRICAL CLASS CERTIFICATION SHALL BE SHOWN ON ALUMINUM DIE-CASTING HOUSING STAMPED USING STAINLESS STEEL TAG PERMANENTLY ATTACHED TO THE DEVICE
- 9 HART COMMUNICATION SHALL BE SUITABLE OVER RANGE OF APPLICATION
- 10 AUSTENSIC 316 SS BOLTS REQUIRED
- 12 MOUNTING BRACKET FOR 2-IN PIPE BY VENDOR (AGCO)
- 13 LCD METER WITH POLYURETHANE COVERED ALUMINUM COVER REQUIRED
- 14 ALL DOCUMENTS TO BE SUBMITTED IN BOTH HARD AND ELECTRONIC FORMAT
- 15 INDICATOR TO SHOW BARG AND °C
- 16 MATERIAL SHALL BE PER APPROVED VENDOR LIST. MANUFACTURER LISTED ABOVE IS FOR REFERENCE.
- 17 ELECTRICAL CONNECTION: M20
- 18 REQUIRED ASSEMBLY AS PER BELOW PIC WITH ISOLATION VALVE
- 19 TRANSMITTERS ARE SUPPLIED WITH THIN FILM TYPE PIEZORESISTIVE SENSORS
- 20 SENSOR FILLING: PAG SYNTHETIC OIL
- 21 REFER TO CONTROL NARRATIVE AND SET POINT LIST FOR THE CONTROLLER ACTION
- 22 HOUSING SHALL BE SELECTED TO SHOW TRANSMITTER LCD AT 90 DEGREE FROM INLET AS SHOWN BELOW.

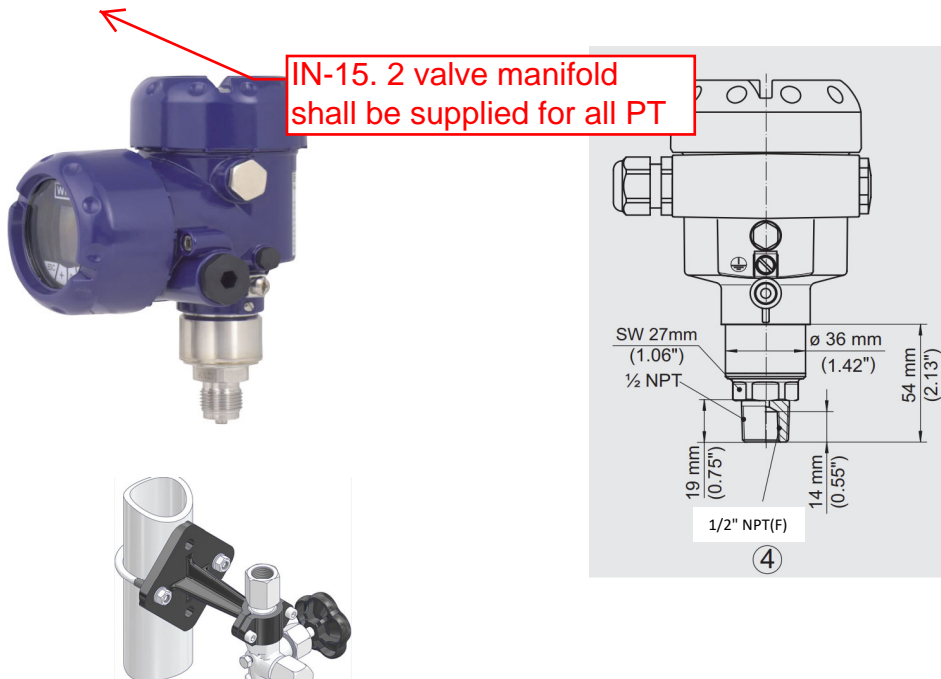

				PRESSURE TRANSMITTER INDICATOR DEVICES		Document No: VD-GPIC-MA-3029-3029-0038-00	
CLIENT: Gachsaran Polymer Industries Company (GPIC) P.O. NO.: GPIC-PT-MA-PO-000-3029 SERVICE: PROPYLENE REFRIGERATION PACKAGE				Document Title: Instrument Data sheet & Catalogs			
		NO.	BY	APP	DATE	P.O.I.	
		00	N.B	A.M	12.10.25	IFR	
GENERAL		1	Tag No.	SEE TABLE BELOW			Service: See Table Below
		2	Qty				
		3	Function	Record <input type="checkbox"/>	Indicate <input checked="" type="checkbox"/>	Control <input type="checkbox"/>	VIA MCS Blind <input type="checkbox"/> Trans <input checked="" type="checkbox"/> Other
		4	Case	Mfr. Std. <input checked="" type="checkbox"/>	Nom. Size	Other NOTE 2	
		5	Mounting	Flush <input type="checkbox"/>	Surface	Other	
		6	Enclosure Class	Gen. Purpose <input type="checkbox"/>	Weather Proof <input type="checkbox"/>	Explosion Proof <input type="checkbox"/>	IIB-T5 - ZONE 1, CL1
		7	Power Supply	117V 60 Hz <input type="checkbox"/>	Other ac <input type="checkbox"/>	DC <input checked="" type="checkbox"/>	Volts 24 V
		8	Chart	N/A	Strip <input type="checkbox"/>	Roll <input type="checkbox"/>	Fold <input type="checkbox"/> Circular <input type="checkbox"/> Time Mark: <input type="checkbox"/>
		9	Chart Drive	N/A	Speed		
		10	Scales	Type: LCD / DIGITAL (UNITS per N)	Range: SEE TABLE BELOW		
XMTR		11	Transmitter Output	4-20 mA <input checked="" type="checkbox"/> NOTE 9	10-50mA <input type="checkbox"/>	21-103 kPa (3-15 psig) <input type="checkbox"/>	Other
		For Receiver, see spec sheet. WIRED TO UCP VIA JUNCTION BOXES (2 WIRE OUTPUT) NOTE 9					
CONTROLLER VIA UCP		12	Control Modes	P = Prop (Gain), I-Integral (Auto Reset), D = Derivative (Rate)			
		Sub: s = slow, f = fast, if <input type="checkbox"/> Df <input type="checkbox"/> P <input type="checkbox"/> PID <input type="checkbox"/> PD <input type="checkbox"/> PI <input type="checkbox"/> Is <input type="checkbox"/> Ds <input type="checkbox"/>					
		14	Action	On Measurement Increase, Output:			Increases <input type="checkbox"/> Decreases <input type="checkbox"/>
		15	Auto-Man Switch	None <input type="checkbox"/>	MFR Std <input type="checkbox"/>	Other <input checked="" type="checkbox"/>	NOTE 21
		16	Set Point Adj.	Manual <input type="checkbox"/>	External <input type="checkbox"/>	Remote <input checked="" type="checkbox"/> UCP	Other NOTE 9
		17	Manual Reg.	None <input type="checkbox"/>	MFR Std <input type="checkbox"/>	Other	
		18	Output	4-20 mA <input type="checkbox"/> NOTE 9	10-50 mA <input type="checkbox"/>	21-103 kPa (3-15 psig) <input type="checkbox"/>	Other
ELEMENT		19	Service	Gage Press <input checked="" type="checkbox"/>	Vacuum <input type="checkbox"/>	Absolute <input type="checkbox"/>	Compound <input type="checkbox"/>
		20	Element Type	Diaphragm <input type="checkbox"/>	Helix <input type="checkbox"/>	Bourdon <input type="checkbox"/>	Bellows <input type="checkbox"/> Other NOTE 19
		21	Material (body)	316SS <input checked="" type="checkbox"/>	Ber Copper <input type="checkbox"/>	Other <input type="checkbox"/>	
		22	Range	Fixed <input type="checkbox"/>	Adj. Range <input checked="" type="checkbox"/>		
		Overrange Protection to: SEE TABLE BELOW					
		23	Process Data	Press.: Nor.: SEE TABLE BELOW	MAX.:	Element Range:	
		24	Process Conn.	1/4" in NPT <input type="checkbox"/>	1/2" in NPT (F) <input checked="" type="checkbox"/>	Other: 1/2" CONDUIT CONNECTION	
		Location: Bottom: <input checked="" type="checkbox"/> Back <input type="checkbox"/> Other					
VIA UCP		25	Alarm Switches	Quantity: BY UCP REFER TO SETPOINT LIST	Form	Rating	
		26	Function	Press. <input checked="" type="checkbox"/>	Deviation <input type="checkbox"/>	Contacts	On Icr. Meas.
OPTIONS		27	Options	Filter Reg. <input type="checkbox"/>	Sup. Gage <input type="checkbox"/>	Output Gage <input type="checkbox"/>	Charts
		Diaphragm Seal <input type="checkbox"/> Type <input type="checkbox"/> Bot. Bowl					
		Conn. Capillary: <input type="checkbox"/> Mtl.					
		Other: ELECTRICAL GROUND SCREW REQUIRED					
AREA CLASSIFICATION		IEC <input checked="" type="checkbox"/> ZONE 1, EExI IIB-IP-67 / NEMA4X				Agency Approval: ATEX	

Item	Qty	Tag No.	Pressure PSIG - BarG		Operating Press. PSIG / BarG		Calibration mA PSIG / BarG		Manufacturer/ (Note 16) Model no.	Service
			Range	Over	Min	Max	4	20		
A	1	PIT-61131	-14.7 to 580	1160	275.6	303.1	0.00	250		PROPYLENE &
		SEPARATOR	-1.01 to 40.0	80.0	19.0	20.6	0.0	17.2		
B	1	PIT-61132	-14.7 to 580	1160	275.6	303.1	0.00	400		PROPYLENE &
		COALESCER	-1.01 to 40.0	80.0	19.0	20.9	0.0	27.6		SYNTHETIC OIL
C	1	PIT-61133	-14.7 to 580	1160	329.0	367.8	0.00	400		PROPYLENE &
		OIL FILTER	-1.01 to 40.0	80.0	22.7	25.0	0.0	27.6		SYNTHETIC OIL
D	1	PIT-61134	-14.7 to 580	1160	290.1	319.1	0.00	400		PROPYLENE &
		OIL FILTER	-1.01 to 40.0	80.0	20.0	22.0	0.0	27.6		SYNTHETIC OIL

				PRESSURE TRANSMITTER INDICATOR DEVICES		Document No: VD-GPIC-MA-3029-3029-0038-00
						Document Title: Instrument Data sheet & Catalogs
NO.	BY	APP	DATE	P.O.I.		
00	N.B	A.M	12.10.25	IFR		
CLIENT: Gachsaran Polymer Industries Company (GPIC) P.O. NO.: GPIC-PT-MA-PO-000-3029 SERVICE: PROPYLENE REFERIGERATION PACKAGE						

Notes:

- 1 SYSTEM DESIGN PRESSURE & TEMPERATURE:

FV to 362.5 PSIG	25.0 BarG	@	250 °F	121 °C	FOR ITEMS: 1, 2
			-45 °F	-43 °C	
FV to 406 PSIG	28.0 BarG	@	250 °F	121 °C	FOR ITEMS: 3
			-20 °F	-29 °C	
- 2 TRANSMITTER ELECTRICAL HOUSING MUST BE POLYURETHANE COVERED ALUMINUM
- 3 REFERENCE ACCURACY: ± 0.1 % OF FULL SCALE & ± 0.15 % GUARANTEED STABILITY OVER FIVE YEARS
- 4 INSTRUMENT SHALL BE SUITABLE FOR **IN-21. "EExia"** ENVIRONMENT
- 5 CALIBRATION CERTIFICATE REQUIRED NOT REQUIRED
- 6 HARD COPY OF IEC-79, EExi IIB-T5 CERTIFICATE REQUIRED NOT REQUIRED
- 7 CUSTOMER SPECIFICATION: N/A, N/A & N/A
- 8 ELECTRICAL CLASS CERTIFICATION SHALL BE SHOWN ON ALUMINUM DIE-CASTING HOUSING STAMPED USING STAINLESS STEEL TAG PERMANENTLY
- 9 ATTACHED TO THE DEVICE
- 10 HART COMMUNICATION SHALL BE SUITABLE OVER RANGE OF APPLICATION
- 12 AUSTENSIC 316 SS BOLTS REQUIRED
- 13 MOUNTING BRACKET FOR 2-IN PIPE BY VENDOR (AGCO)
- 14 LCD METER WITH POLYURETHANE COVERED ALUMINUM COVER REQUIRED
- 15 ALL DOCUMENTS TO BE SUBMITTED IN BOTH HARD AND ELECTRONIC FORMAT
- 16 INDICATOR TO SHOW BARG AND °C
- 17 MATERIAL SHALL BE PER APPROVED VENDOR LIST. MANUFACTURER LISTED ABOVE IS FOR REFERENCE.
- 18 ELECTRICAL CONNECTION: M20
- 19 REQUIRED ASSEMBLY AS PER BELOW PIC WITH ISOLATION VALVE
- 20 TRANSMITTERS ARE SUPPLIED WITH THIN FILM TYPE PIEZORESISTIVE SENSORS
- 21 SENSOR FILLING: PAG SYNTHETIC OIL
- 22 REFER TO CONTROL NARRATIVE AND SET POINT LIST FOR THE CONTROLLER ACTION
HOUSING SHALL BE SELECTED TO SHOW TRANSMITTER LCD AT 90 DEGREE FROM INLET AS SHOWN BELOW.

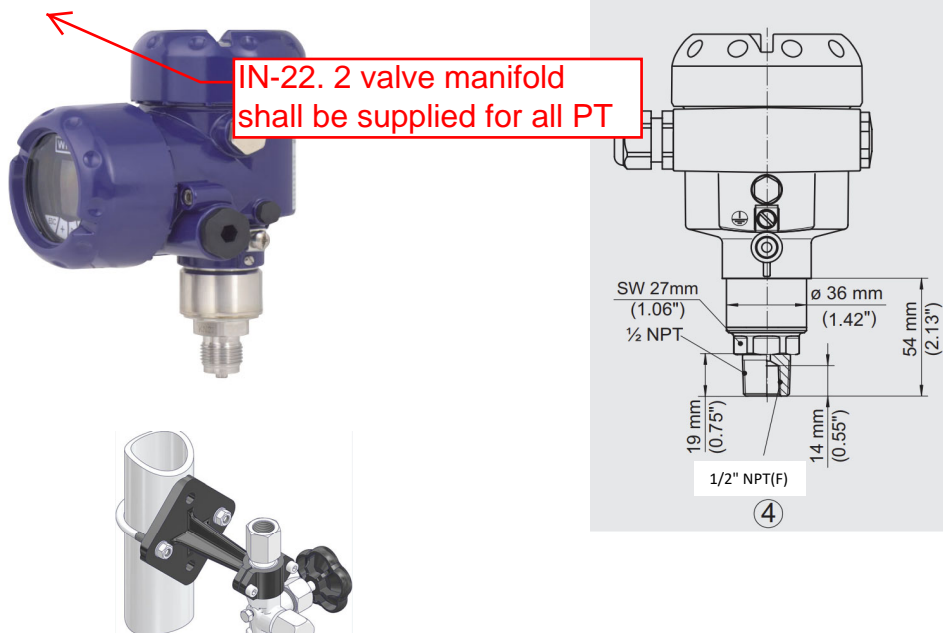

CLIENT: Gachsaran Polymer Industries Company (GPIC)
P.O. NO.: GPIC-PT-MA-PO-000-3029
SERVICE: PROPYLENE REFERIGERATION PACKAGE

IN-24. Please clarify that what is the meaning of "Rack Mount". Generally TT is located in field not in the panel.

GENERAL	1	Tag No.	SEE	SEE TABLE BELOW			
	2	Function	Record <input type="checkbox"/> Indicate <input checked="" type="checkbox"/> Control <input checked="" type="checkbox"/> Blind <input type="checkbox"/> Trans <input checked="" type="checkbox"/> Other				
	3	Case	MFR. Std. <input type="checkbox"/> Nom <input type="checkbox"/> Surface <input type="checkbox"/> Yoke <input checked="" type="checkbox"/> Other RACK MOUNT				
	4	Mounting	Flush <input type="checkbox"/> Surface <input type="checkbox"/> Yoke <input checked="" type="checkbox"/> Other RACK MOUNT				
	5	Enclosure Class	Gen. Purpose <input type="checkbox"/> Weather Proof <input type="checkbox"/> Explosion Proof <input type="checkbox"/> Use in intrinsically <input checked="" type="checkbox"/> Safe System <input type="checkbox"/> Other <input checked="" type="checkbox"/> IIB-T5 - ZONE 2, CL1				
	6	Power Supply	117V 60 Hz <input type="checkbox"/> Strip <input type="checkbox"/> Roll <input type="checkbox"/> Power <input type="checkbox"/> Time marks <input type="checkbox"/>				
	7	Chart	Speed <input type="checkbox"/> Power <input type="checkbox"/>				
	8	Chart Drive	Scale <input type="checkbox"/> Type: _____ Range: _____				
	9	Scale	4-20 mA <input checked="" type="checkbox"/> 10-50mA <input type="checkbox"/> 21-103 kPa (3-15 psig) <input type="checkbox"/> Other				
XMTR	10	Output	NOTE 12				
CONTROLLER VIA N/A	11	Control Modes	For Receiver, see spec sheet. WIRED TO UCP VIA JUNCTION BOXES (2 WIRE OUTPUT) NOTE 12 P = Prop (Gain), I = Integral (Auto Reset), D = Derivative (Rate) Sub: s = slow, f = fast, _____ If <input type="checkbox"/> Df <input type="checkbox"/> P <input type="checkbox"/> PI <input type="checkbox"/> PD <input checked="" type="checkbox"/> PID <input type="checkbox"/> Is <input type="checkbox"/> Ds <input type="checkbox"/>				
	12	Action	On Measurement Increase, Output: _____ Increases <input type="checkbox"/> Decreases <input type="checkbox"/>				
	13	Auto-Man Switch	None <input type="checkbox"/> MFR Std <input type="checkbox"/> Other <input checked="" type="checkbox"/> NOTE 18				
	14	Set Point Adj.	Manual <input type="checkbox"/> External <input type="checkbox"/> Remote <input checked="" type="checkbox"/> UCP NOTE 12				
	15	Manual Reg.	None <input type="checkbox"/> MFR Std <input type="checkbox"/> Other				
	16	Output	4-20 mA <input type="checkbox"/> 10-50mA <input type="checkbox"/> 21-103 kPa (3-15 psig) <input type="checkbox"/> Other				
ELEMENT	17	Fill	SAMA Class _____ Compensation _____				
	18	Process Data	SEE TABLE BELOW				
	19	Range	Fixed <input type="checkbox"/> Adj. Range <input type="checkbox"/> Set @ SEE BELOW				
	20	Bulb	Overrange Protection to: _____ Electrical Connection: M20 1/2" NPT Type: RTD-Pt-100 α = 0.00385 Sheath Material: 316 S.S W/ MINERAL INSULATION Size: SEE TABLE BELOW Diameter: 1/4" Number of Wires: 3 WIRES (DUAL) NOTE 15				
	21						
	22						
	23	Alarm Switches	Quantity: _____				
VIA UCP	24	Function	Temp. <input checked="" type="checkbox"/> Deviation <input type="checkbox"/> On Temp. Incr. _____				
	25	Options	Filter Reg. _____ Sup Gage <input type="checkbox"/> Charts <input type="checkbox"/>				
	26		Other: _____				
AREA CLASS.	27		IEC <input checked="" type="checkbox"/> ZONE 1, EExI IIB-T5 IP-66 / NEMA4X Agency Approval: ATEX				

IN-25. add "EExia"

IN-26. "EExia"

TRANSMITTER

Item	Qty	Tag No.	Temperature °F / °C		Oper. Press. PSIG BARG		Calibration (mA) °F / °C		Manufacturer / Model No.	Service
			Range	Oper.	Min.	Max.	4	20		
A	1	TIT 61141 ECONOMIZER	-328 to 1562	45.77	85.5	96.4	-58	212		HYDROCARBON GAS & SYNTHETIC OIL
B										
C										
D										
E										

IN-27. "TT"



TEMPERATURE TRANSMITTER CONTROL DEVICES

Document No: VD-GPIC-MA-3029-3029-0038-00
 Document Title: Instrument Data sheet & Catalogs

NO.	BY	APP	DATE	P.O.I.
00	N.B	A.M	12.10.25	IFR

CLIENT: Gachsaran Polymer Industries Company (GPIC)
 P.O. NO.: GPIC-PT-MA-PO-000-3029
 SERVICE: PROPYLENE REFERIGERATION PACKAGE

SENSOR WITH THERMOWELL

Item	Qty	Tag No.	Range °F (°C)	Oper. Temp. °F (°C)	LG (L) = (U+H) IN (mm)	Well Conn. Proc./Inst.	EXT. (N)	Ins (U) IN (mm)	LAG (H)	Well Type	Head Mtg	Model Number Sensor/Well
A	1	TE-61141 INLET	-148 to 842 -100 to 450	45.8 7.65	10 " 254 mm	1-1/2" - 300# RF 1/2" NPT	3.0 " 76.2	4.0 " 101.6	3.0 76.2	TAPERED	YES	
B												
C												
D												
E												

IN-28. Well material shall be specified as 316SS.

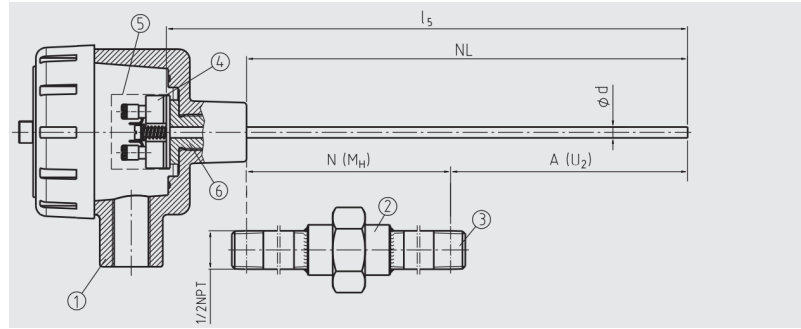
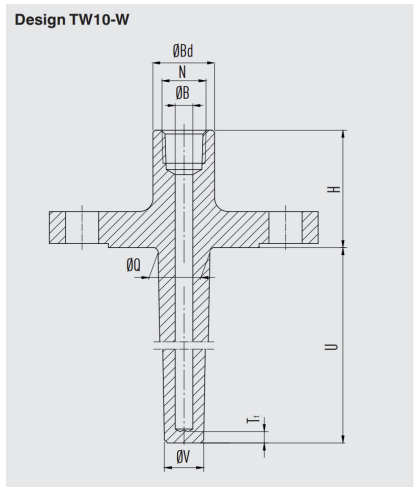
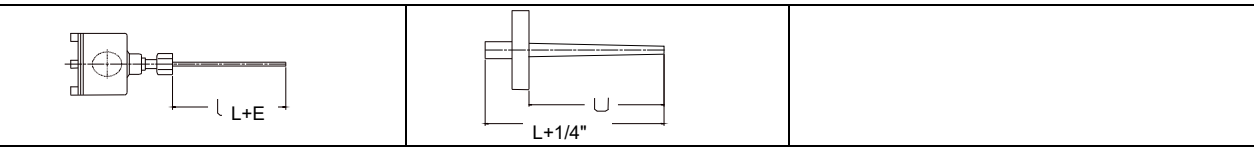



TEMPERATURE TRANSMITTER CONTROL DEVICES

Document No: VD-GPIC-MA-3029-3029-0038-00
 Document Title: Instrument Data sheet & Catalogs

NO.	BY	APP	DATE	P.O.I.
00	N.B	A.M	12.10.25	IFR

CLIENT: Gachsaran Polymer Industries Company (GPIC)
 P.O. NO.: GPIC-PT-MA-PO-000-3029
 SERVICE: PROPYLENE REFERIGERATION PACKAGE

Notes:

- SYSTEM DESIGN PRESSURE & TEMPERATURE: FV to 362.5 PSIG 25.0 BarG @ 250 °F 121 °C FOR ITEMS: 1
 FV to 406 PSIG 28.0 BarG @ 250 °F 121 °C FOR ITEMS:
 -45 °F -43 °C
 -20 °F -29 °C
- TRANSMITTER AND SENSOR ELECTRICAL HOUSING MUST BE POLYURETHANE COVERED DIE ALUMINUM-HOUSING, THERMOWELL IS 316 STAINLESS STEEL
- REFERENCE ACCURACY: +/- 0.075 % OF FULL SCALE & +/- 0.15 % GUARRANTEED STABILITY OVER FIVE YEARS
- INSTRUMENT SHALL BE SUITABLE FOR MARIN **IN-29. "EExia"** ENT
- CALIBRATION CERTIFICATE REQUIRED NOT REQUIRED
- HARD COPY OF IIEC-79, EExi **IB-T5** CERTIFICATE REQUIRED NOT REQUIRED
- CUSTOMER SPECIFICATION: N/A & N/A
- ELECTRICAL CLASS CERTIFICATION SHALL BE SHOWN ON ALUMINUM DIE-CASTING HOUSING STAMPED USING STAINLESS STEEL TAG PERMANENTLY ATTACHED TO THE DEVICE
- ALL DOCUMENTS TO BE SUBMITTED IN BOTH HARD AND ELECTRONIC FORMAT
- TERMINAL HEAD TO BE ASSEMBLED WITH THERMOWELL USING A UNION
- EXTENSION SECTION OF 3 INCHES (76.2 mm) TO INCLUDE NIPPLE AND UNION
- "SMART" ELECTRONIC TRANSMITTERS WITH "HART PROTOCOL" COMMUNICATION SHALL BE SUITABLE OVER RANGE OF APPLICATION
- EACH TEMPERATURE TRANSMITTER SHALL INCLUDE A MOUNTING BRACKET FOR 2-IN PIPE RACK
- INDICATOR TO SHOW Barg AND °C
- MATERIAL SHALL BE PER APPROVED VENDOR LIST. MANUFACTURER LISTED ABOVE IS FOR REFERENCE.
- BOTH RTD ELEMENTS ARE WIRED AND TERMINATED IN TERMINAL HEAD
- REQUIRED ASSEMBLY AS PER BELOW PICTURES WITH A UNION. ELEMENT LENGTH SHALL BE ADJUSTED FOR THE UNION USE.
- RTD TO BE TERMINATED IN THE TERMINAL HEAD, AND TRANSMITTER TO BE INSTALLED REMOTELY
- REFER TO CONTROL NARRATIVE AND SET POINT LIST FOR THE CONTROLLER ACTION
- THERMOWELL NATURAL FREQUENCE CALCULATION REQUIRED



THERMOWELL & HEAD



REMOTE TRANSMITTER WITH ELECTRONIC DISPLAY

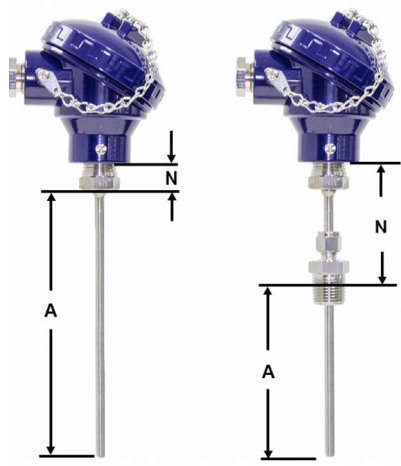

$A = U + H$

IN-30. Please clarify that what is the meaning of "Rack Mount". Generally TT is located in field not in the panel.

GENERAL	1	Tag No.	SEE TABLE BELOW	Service:	SEE TABLE BELOW
	2	Function	Record <input type="checkbox"/> Indicate <input checked="" type="checkbox"/> Control <input type="checkbox"/> Blind <input type="checkbox"/> Trans <input checked="" type="checkbox"/> Other		
	3	Case	MFR. Std. <input type="checkbox"/> Non <input type="checkbox"/> Nom <input type="checkbox"/> Surfa <input type="checkbox"/> Other NOTE 2		
	4	Mounting	Flush <input type="checkbox"/> Surfa <input type="checkbox"/> Other RACK MOUNT		
	5	Enclosure Class	Gen. Purpose <input type="checkbox"/> Weather Proof <input type="checkbox"/> Explosion Proof <input type="checkbox"/> Use in intrinsically <input checked="" type="checkbox"/> Safe System <input type="checkbox"/> Other <input checked="" type="checkbox"/> IIB-T5 - ZONE 2, CL1		
	6	Power Supply	117V 60 Hz <input type="checkbox"/> Other ac <input type="checkbox"/> DC <input checked="" type="checkbox"/> Volts 24 V		
	7	Chart	Strip <input type="checkbox"/> Roll <input type="checkbox"/> Fold <input type="checkbox"/> Circular <input type="checkbox"/> Time marks <input type="checkbox"/>		
	8	Chart Drive	Speed <input type="checkbox"/> Power <input type="checkbox"/>		
	9	Scale	Type: <input type="checkbox"/> Range: <input type="checkbox"/>		
XMTR	10	Output	NOTE 12 4-20 mA <input checked="" type="checkbox"/> 10-50mA <input type="checkbox"/> 21-103 kPa (3-15 psig) <input type="checkbox"/> Other		
	11	Control Modes	For Receiver, see spec sheet. WIRED TO UCP VIA JUNCTION BOXES (2 WIRE OUTPUT) NOTE 12 P = Prop (Gain), I = Integral (Auto Reset), D = Derivative (Rate) Sub: s = slow, f = fast, If <input type="checkbox"/> Df <input type="checkbox"/> P <input type="checkbox"/> PI <input type="checkbox"/> PD <input type="checkbox"/> PID <input type="checkbox"/> Is <input type="checkbox"/> Ds <input type="checkbox"/>		
CONTROLLER VIA N/A	12	Action	On Measurement Increase, Output: Increases <input type="checkbox"/> Decreases <input type="checkbox"/>		
	13	Auto-Man Switch	None <input type="checkbox"/> MFR Std <input type="checkbox"/> Other		
	14	Set Point Adj.	Manual <input type="checkbox"/> External <input type="checkbox"/> Remote <input checked="" type="checkbox"/> UCP NOTE 12		
	15	Manual Reg.	None <input type="checkbox"/> MFR Std <input type="checkbox"/> Other		
	16	Output	4-20 mA <input type="checkbox"/> 10-50mA <input type="checkbox"/> 21-103 kPa (3-15 psig) <input type="checkbox"/> Other		
	ELEMENT	17	Fill	SAMA Class	Compensation
18		Process Data	SEE TABLE BELOW	Compensation	
19		Range	Fixed <input type="checkbox"/> Adj. Range <input type="checkbox"/> Set @ SEE BELOW		
20		Bulb	Overrange Protection to: RTD-Pt-100 α = 0.00385 Type: RTD-Pt-100 α = 0.00385 Size: SEE TABLE BELOW Diameter: 1/4" Number of Wires: 3 WIRES (DUAL) NOTE 15	Electrical Connection: M20 Sheath Material: 316 S.S W/ MINERAL INSULATION	
21					
22					
23		Alarm Switches	Quantity: <input type="checkbox"/> Form <input type="checkbox"/> Rating <input type="checkbox"/>		
24		Function	Temp. <input checked="" type="checkbox"/> Deviation <input type="checkbox"/> On Temp. Incr. <input type="checkbox"/>		
25		Options	Filter Reg. <input type="checkbox"/> Sup Gage <input type="checkbox"/> Charts <input type="checkbox"/>		
26			Other: <input type="checkbox"/>		
AREA CLASS.	27		IEC <input checked="" type="checkbox"/> ZONE 1, EEx IIB-T5 IP-66 / NEMA4X Agency Approval: ATEX		

IN-31. add "EExia"

IN-32. "EExia"

TRANSMITTER

Item	Qty	Tag No.	Temperature °F / °C		Oper. Press. PSIG BARG		Calibration (mA) °F / °C		Manufacturer / Model No.	Service
			Range	Oper.	Min.	Max.	4	20		
A	1	TIT-61111	-328 to 1562	-12.44	22.5	24.8	-58	212		HYDROCARBON GAS &
		SUCTION	-200 to 850	-24.69	1.55	1.69	-50	100		SYNTHETIC OIL
B		TIT-61132	-328 to 1562	120	304.6	335.0	-58	212		HYDROCARBON GAS &
		OIL SUPPLY	-200 to 850	48.89	21.0	22.8	-50	100		SYNTHETIC OIL
C										
D		TIT-61131	-328 to 1562	171.86	275.6	310.6	-58	212		HYDROCARBON GAS &
		OIL SEPARATOR	-200 to 850	77.70	19.0	21.1	-50	100		SYNTHETIC OIL
E										

IN-33. "TT"





TEMPERATURE TRANSMITTER INDICATOR DEVICES				Document No:	VD-GPIC-MA-3029-3029-0038-00
				Document Title:	Instrument Data sheet & Catalogs
NO.	BY	APP	DATE	P.O.I.	
00	N.B	A.M	12.10.25	IFR	

CLIENT: Gachsaran Polymer Industries Company (GPIC)
P.O. NO.: GPIC-PT-MA-PO-000-3029
SERVICE: PROPYLENE REFRIGERATION PACKAGE

SENSOR WITH THERMOWELL												
Item	Qty	Tag No.	Range °F (°C)	Oper. Temp. °F (°C)	LG (L) = (U+H) IN (mm)	Well Conn. Proc./Inst.	EXT. (N)	Ins (U) IN (mm)	LAG (H)	Well Type	Head Mtg	Model Number Sensor/Well
A	1	TE-61111 INLET	-148 to 842 -100 to 450	-12.4 -24.69	18 " 457 mm	1-1/2"- 300# RF 1/2" NPT	3.0 " 76.2	12.0 " 304.8	3.0 76.2	TAPERED	YES	
B		TE-61132 OIL SUPPLY	-148 to 842 -100 to 450	120.0 50	12 " 305 mm	1-1/2"- 300# RF 1/2" NPT	3.0 " 76.2	6.0 " 152.4	3.0 76.2	TAPERED	YES	
C												
D		TE-61131 OIL SEPARATOR	-148 to 842 -100 to 450	171.9 77.70	24 " 610 mm	1-1/2"- 300# RF 1/2" NPT	3.0 " 76.2	18.0 " 457.2	3.0 76.2	TAPERED	YES	
E												

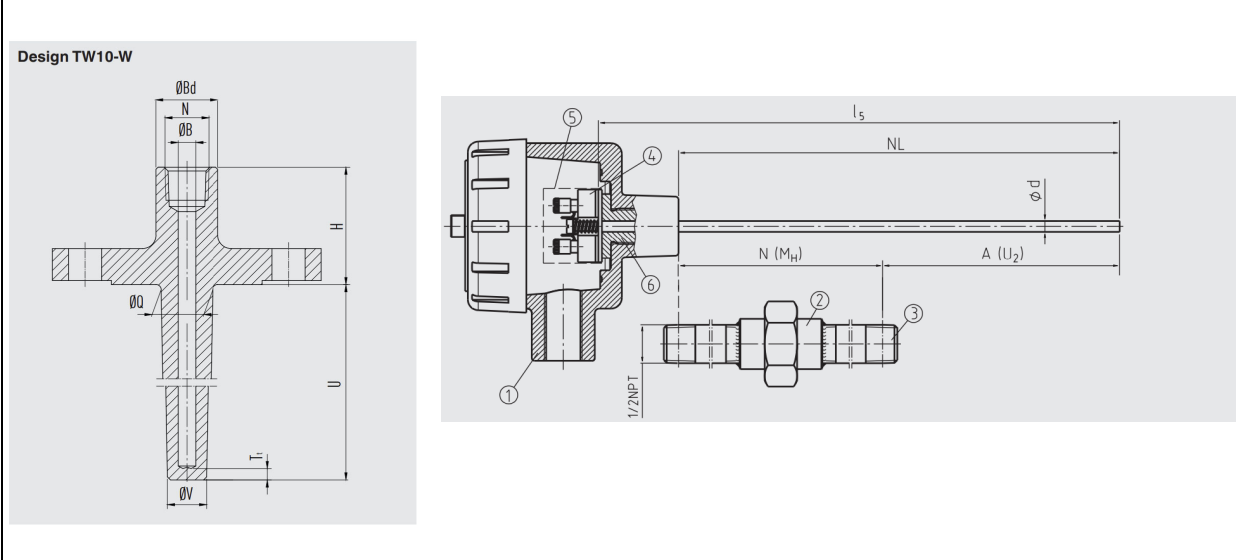
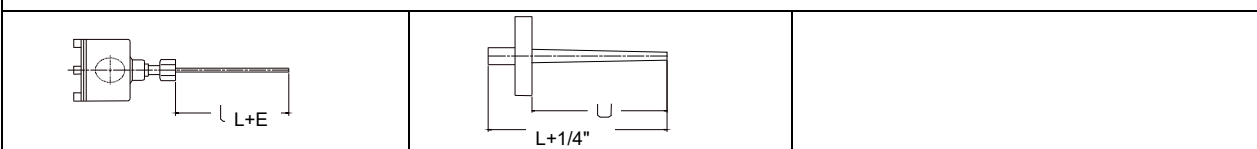
IN-34. Well material shall be specified as 316SS.



	TEMPERATURE TRANSMITTER INDICATOR DEVICES				Document No: VD-GPIC-MA-3029-3029-0038-00
					Document Title: Instrument Data sheet & Catalogs
CLIENT: Gachsaran Polymer Industries Company (GPIC) P.O. NO.: GPIC-PT-MA-PO-000-3029 SERVICE: PROPYLENE REFERIGERATION PACKAGE	NO.	BY	APP	DATE	P.O.I.
	00	N.B	A.M	12.10.25	IFR

- Notes:
- SYSTEM DESIGN PRESSURE & TEMPERATURE:

FV to 362.5 PSIG	25.0 BarG	@	250 °F	121 °C	FOR ITEMS: 1, 3
FV to 406 PSIG	28.0 BarG	@	-45 °F	-43 °C	
			250 °F	121 °C	FOR ITEMS: 2
			-20 °F	-29 °C	
 - TRANSMITTER AND SENSOR ELECTRICAL HOUSING MUST BE POLYURETHANE COVERED DIE ALUMINUM-HOUSING, THERMOWELL IS 316 STAINLESS STEEL
 - REFERENCE ACCURACY: +/- 0.075 % OF FULL SCALE & +/- 0.15 % GUARRANTEED STABILITY OVER FIVE YEARS
 - INSTRUMENT SHALL BE SUITABLE FOR HAZARDOUS AREA **IN-35. "EExia"** MENT
 - CALIBRATION CERTIFICATE REQUIRED NOT REQUIRED
 - HARD COPY OF IIEC-79, EExi IIB-T5 CERTIFICATE REQUIRED NOT REQUIRED
 - CUSTOMER SPECIFICATION: N/A & N/A
 - ELECTRICAL CLASS CERTIFICATION SHALL BE SHOWN ON ALUMINUM DIE-CASTING HOUSING STAMPED USING STAINLESS STEEL TAG PERMANENTLY ATTACHED TO THE DEVICE
 - ALL DOCUMENTS TO BE SUBMITTED IN BOTH HARD AND ELECTRONIC FORMAT
 - TERMINAL HEAD TO BE ASSEMBLED WITH THERMOWELL USING A UNION
 - EXTENSION SECTION OF 3 INCHES (76.2 mm) TO INCLUDE NIPPLE AND UNION
 - "SMART" ELECTRONIC TRANSMITTERS WITH "HART PROTOCOL" COMMUNICATION SHALL BE SUITABLE OVER RANGE OF APPLICATION
 - EACH TEMPERATURE TRANSMITTER SHALL INCLUDE A MOUNTING BRACKET FOR 2-IN PIPE RACK
 - INDICATOR TO SHOW Barg AND °C
 - MATERIAL SHALL BE PER APPROVED VENDOR LIST. MANUFACTURER LISTED ABOVE IS FOR REFERENCE.
 - BOTH RTD ELEMENTS ARE WIRED AND TERMINATED IN TERMINAL HEAD OR-TRANSMITTER
 - REQUIRED ASSEMBLY AS PER BELOW PICTURES WITH A UNION. ELEMENT LENGTH SHALL BE ADJUSTED FOR THE UNION USE.
 - RTD TO BE TERMINATED IN THE TERMINAL HEAD, AND TRANSMITTER TO BE INSTALLED REMOTELY
 - REFER TO CONTROL NARRATIVE AND SET POINT LIST FOR THE CONTROLLER ACTION
 - THERMOWELL NATURAL FREQUENCE CALCULATION REQUIRED



THERMOWELL & HEAD



REMOTE TRANSMITTER WITH ELECTRONIC DISPLAY

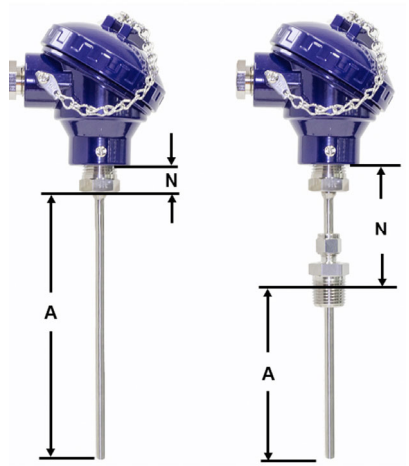

A = U + H

IN-36. Please clarify that what is the meaning of "Rack Mount". Generally TT is located in field not in the panel.

IN-37. add "EExia"

IN-38. "EExia"

IN-39. "TT"

GENERAL	1	Tag No.	SEE TABLE BELOW	Service:	SEE TABLE BELOW
	2	Function	Record <input type="checkbox"/> Indicate <input checked="" type="checkbox"/> Control <input type="checkbox"/> Trans <input checked="" type="checkbox"/> Other <input type="checkbox"/>		
	3	Case	MFR. Std. <input type="checkbox"/> Nom <input type="checkbox"/>		NOTE 2
	4	Mounting	Flush <input type="checkbox"/>		Other RACK MOUNT
	5	Enclosure Class	Gen. Purpose <input type="checkbox"/> Weather Proof <input type="checkbox"/> Explosion Proof <input type="checkbox"/>		
	6	Power Supply	Use in intrinsically <input checked="" type="checkbox"/> Safe System <input type="checkbox"/> Other <input checked="" type="checkbox"/>		IIB-T5 - ZONE 2, CL1
	7	Chart	117V 60 Hz <input type="checkbox"/> Other ac <input type="checkbox"/> DC <input checked="" type="checkbox"/> Volts 24 V		
	8	Chart Drive	Strip <input type="checkbox"/> Roll <input type="checkbox"/> Fold <input type="checkbox"/> Circular <input type="checkbox"/> Time marks <input type="checkbox"/>		
	9	Scale	Speed <input type="checkbox"/> Power <input type="checkbox"/>		
XMTR	10	Output	4-20 mA <input checked="" type="checkbox"/> 10-50mA <input type="checkbox"/> 21-103 kPa (3-15 psig) <input type="checkbox"/> Other <input type="checkbox"/>		
	11	Control Modes	For Receiver, see spec sheet. WIRED TO UCP VIA JUNCTION BOXES (2 WIRE OUTPUT) NOTE 12 P = Prop (Gain), I = Integral (Auto Reset), D = Derivative (Rate) Sub: s = slow, f = fast, If <input type="checkbox"/> Df <input type="checkbox"/> P <input type="checkbox"/> PI <input type="checkbox"/> PD <input type="checkbox"/> PID <input type="checkbox"/> Is <input type="checkbox"/> Ds <input type="checkbox"/>		
CONTROLLER VIA N/A	12	Action	On Measurement Increase, Output: Increases <input type="checkbox"/> Decreases <input type="checkbox"/>		
	13	Auto-Man Switch	None <input type="checkbox"/> MFR Std <input type="checkbox"/> Other <input type="checkbox"/>		
	14	Set Point Adj.	Manual <input type="checkbox"/> External <input type="checkbox"/> Remote <input checked="" type="checkbox"/>		UCP NOTE 12
	15	Manual Reg.	None <input type="checkbox"/> MFR Std <input type="checkbox"/> Other <input type="checkbox"/>		
	16	Output	4-20 mA <input type="checkbox"/> 10-50mA <input type="checkbox"/> 21-103 kPa (3-15 psig) <input type="checkbox"/> Other <input type="checkbox"/>		
	ELEMENT	17	Fill	SAMA Class	Compensation
18		Process Data	SEE TABLE BELOW	Compensation	
19		Range	Fixed <input type="checkbox"/> Adj. Range <input type="checkbox"/> Set @	SEE BELOW	
20		Bulb	Overrange Protection to: Electrical Connection: M20 Type: RTD-Pt-100 $\alpha = 0.00385$ Sheath Material: 316 S.S W/ MINERAL INSULATION Size: SEE TABLE BELOW Diameter: 1/4" Number of Wires: 3 WIRES (DUAL) NOTE 15		
21					
22					
23		Alarm Switches	Quantity: Form	Rating:	
24		Function	Temp. <input checked="" type="checkbox"/> Deviation <input type="checkbox"/>		On Temp. Incr. Charts <input type="checkbox"/>
25	Options	Filter Reg. <input type="checkbox"/> Sup Gage <input type="checkbox"/>			
26		Other: <input type="checkbox"/>			
27	AREA CLASS.	IEC <input checked="" type="checkbox"/> ZONE 1, EExI IIB-T5 IP-66 / NEMA4X Agency Approval: ATEX			

TRANSMITTER										
Item	Qty	Tag No.	Temperature °F / °C		Oper. Press. PSIG BARG		Calibration (mA) °F / °C		Manufacturer / Model No.	Service
			Range	Oper.	Min.	Max.	4	20		
A	1	TIT-51121 SUCTION	-328 to 1562	-12.44	22.5	24.8	-58	212		HYDROCARBON GAS & SYNTHETIC OIL
B										
C										
D										
E										



TEMPERATURE INDICATOR DEVICES				Document No: VD-GPIC-MA-3029-3029-0038-00
				Document Title: Instrument Data sheet & Catalogs
NO.	BY	APP	DATE	P.O.I.
00	N.B	A.M	12.10.25	IFR

CLIENT: Gachsaran Polymer Industries Company (GPIC)
 P.O. NO.: GPIC-PT-MA-PO-000-3029
 SERVICE: PROPYLENE REFRIGERATION PACKAGE

SENSOR WITH THERMOWELL

Item	Qty	Tag No.	Range °F (°C)	Oper. Temp. °F (°C)	LG (L) = (U+H) IN (mm)	Well Conn. Proc./Inst.	EXT. (N)	Ins (U) IN (mm)	LAG (H)	Well Type	Head Mtg	Model Number Sensor/Well
A	1	TE-61121 INLET	-148 to 842 -100 to 450	-12.4 -24.69	18 " 457 mm	1-1/2" - 300# RF 1/2" NPT	3.0 " 76.2	12.0 " 304.8	3.0 76.2	TAPERED	YES	
B												
C												
D												
E												

IN-40. Well material shall be specified as 316SS.

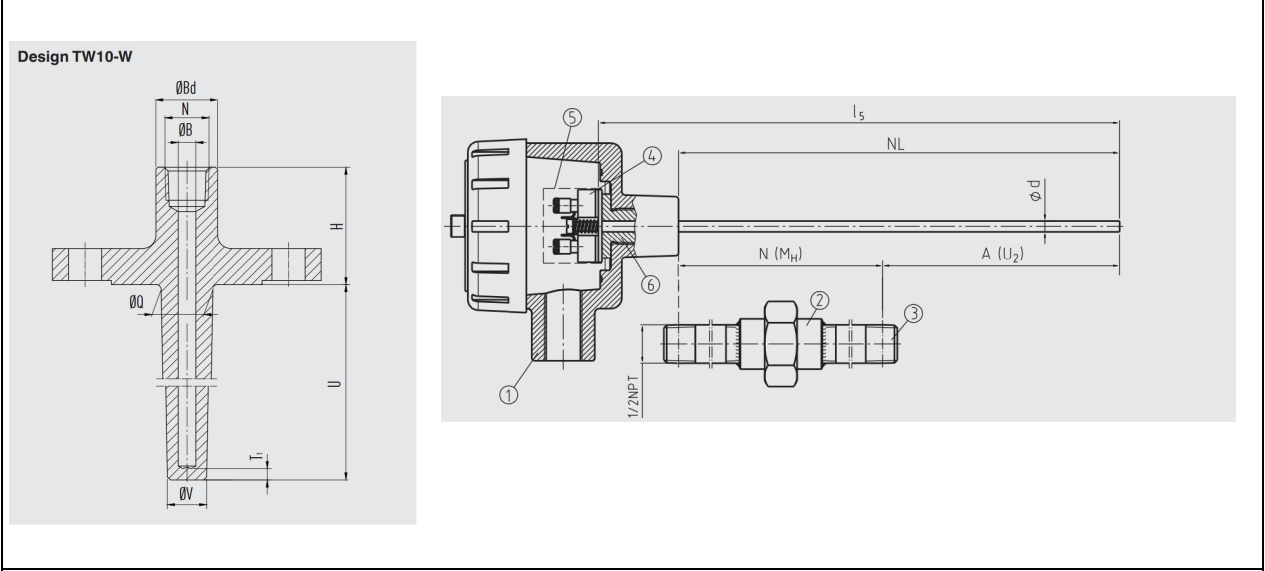
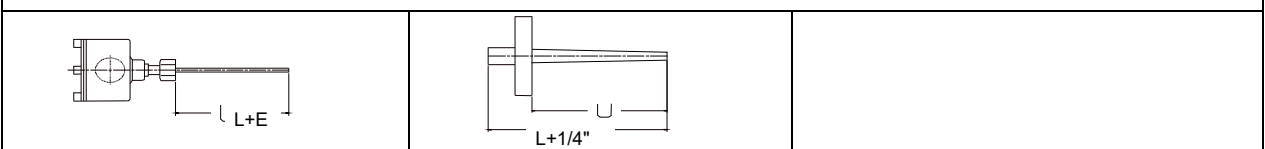

	TEMPERATURE TRANSMITTER INDICATOR DEVICES				Document No: VD-GPIC-MA-3029-3029-0038-00
					Document Title: Instrument Data sheet & Catalogs
CLIENT: Gachsaran Polymer Industries Company (GPIC) P.O. NO.: GPIC-PT-MA-PO-000-3029 SERVICE: PROPYLENE REFERIGERATION PACKAGE	NO.	BY	APP	DATE	P.O.I.
	00	N.B	A.M	12.10.25	IFR

- Notes:
- SYSTEM DESIGN PRESSURE & TEMPERATURE:

FV to	362.5 PSIG	25.0 BarG	@	250 °F	121 °C	FOR ITEMS:	1
				-45 °F	-43 °C		
FV to	406 PSIG	28.0 BarG	@	250 °F	121 °C	FOR ITEMS:	
				-20 °F	-29 °C		
 - TRANSMITTER AND SENSOR ELECTRICAL HOUSING MUST BE POLYURETHANE COVERED DIE ALUMINUM-HOUSING, THERMOWELL IS 316 STAINLESS STEEL
 - REFERENCE ACCURACY: +/- 0.075 & +/- 0.15 % GUARRANTEED STABILITY OVER FIVE YEARS
 - INSTRUMENT SHALL BE SUITABLE FOR MARIN **IN-41. "EExia"** MENT
 - CALIBRATION CERTIFICATE REQUIRED NOT REQUIRED
 - HARD COPY OF IIEC-79, EExi IIB-T5 CERTIFICATE REQUIRED NOT REQUIRED
 - CUSTOMER SPECIFICATION: N/A & N/A
 - ELECTRICAL CLASS CERTIFICATION SHALL BE SHOWN ON ALUMINUM DIE-CASTING HOUSING STAMPED USING STAINLESS STEEL TAG PERMANENTLY ATTACHED TO THE DEVICE
 - ALL DOCUMENTS TO BE SUBMITTED IN BOTH HARD AND ELECTRONIC FORMAT
 - TERMINAL HEAD TO BE ASSEMBLED WITH THERMOWELL USING A UNION
 - EXTENSION SECTION OF 3 INCHES (76.2 mm) TO INCLUDE NIPPLE AND UNION
 - "SMART" ELECTRONIC TRANSMITTERS WITH "HART PROTOCOL" COMMUNICATION SHALL BE SUITABLE OVER RANGE OF APPLICATION
 - EACH TEMPERATURE TRANSMITTER SHALL INCLUDE A MOUNTING BRACKET FOR 2-IN PIPE RACK
 - INDICATOR TO SHOW Barg AND °C
 - MATERIAL SHALL BE PER APPROVED VENDOR LIST. MANUFACTURER LISTED ABOVE IS FOR REFERENCE.
 - BOTH RTD ELEMENTS ARE WIRED AND TERMINATED IN TERMINAL HEAD
 - REQUIRED ASSEMBLY AS PER BELOW PICTURES WITH A UNION. ELEMENT LENGTH SHALL BE ADJUSTED FOR THE UNION USE.
 - RTD TO BE TERMINATED IN THE TERMINAL HEAD, AND TRANSMITTER TO BE INSTALLED REMOTELY
 - REFER TO CONTROL NARRATIVE AND SET POINT LIST FOR THE CONTROLLER ACTION
 - THERMOWELL NATURAL FREQUENCE CALCULATION REQUIRED



THERMOWELL & HEAD



REMOTE TRANSMITTER WITH ELECTRONIC DISPLAY

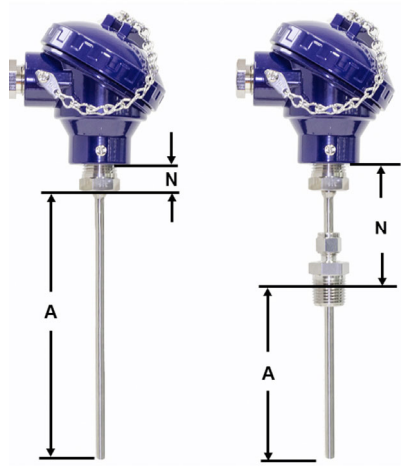

$A = U + H$

	GAUGES GLASSES & COCKS	Document No:	VD-GPIC-MA-3029-3029-0038-00	
		Document Title:	Instrument Data sheet & Catalogs	
NO.	BY	APP	DATE	P.O.I.
00	N.B	A.M	12.10.25	IFR
CLIENT: Gachsaran Polymer Industries Company (GPIC) P.O. NO.: GPIC-PT-MA-PO-000-3029 SERVICE: PROPYLENE REFERIGERATION PACKAGE				

1. Gage Column Assembled w/ Nipples Cocks Unassembled

GAGE CLASSES

2. Type: Reflex Large Chamber Transparent Tubular Weld Pad

3. Conn. Size & Type 2"-300# ANSI RF FLG
 Top & Bottom Side Back
 Vent Drain

4. Material: Body / Cover **LT C.S. (SA350-LF2) OR SS**
 Glass **Borosilicate (TEMPERED)**

5. Min. Rating **SEE NOTES BELOW**

6. Options: Illuminator Mica Shield
 Internal Tube External Jkt.
 Non Frost External Length
 Calb. Scale Other

7. Manufacturer & Model:

GAGE COCKS

8. Type: Offset Straight

9. Conn. Vessel 2"-300# Gage 1/2" Vent / Drain 1/2" W/VALVES

10. Mat: Body: **S.S. A182** Trim: **316 SS**

11. Min. Rating: **507.5 PSIG @ 300 °F**

12. Construction: **INTEGRAL BALL-CHECK / UNION**

13. Type of Conn.: Vessel: **NPT (M) UNION CONNECTOR**
 Gage: **NPT (F) UNION CONNECTOR**
 Vent / Drain: **NPT (F)**
 Other: **DIRECT MOUNT**

14. Bonnet: **PACKING NUT / TEFLON PACKING**

15. Options: Ball Checks Renewal Seats
 Other: **RENEWAL SEATS**

16. Manufacturer & Model: **OTHERS**

17. Bolting Material: **A193-L7 / A194-7**

Item	Qty.	Tag No.	Visible Glass	OVERALL LENGTH	Model No.	Operating		Service
						Pressure PSIG (BarG)	Temp. °F (°C)	
A	1	LG-61141 RECEIVER HEADER	36.0 " 914 mm	36.0 " 914 mm	L21SR/1219.2/A2"300lbR F/N/Ex	268.4 18.5	117.3 47.4	PROPYLENE REFRIGERANT & SYNTHETIC OIL
B								
B								

	GAUGES GLASSES & COCKS				Document No:	VD-GPIC-MA-3029-3029-0038-00
					Document Title:	Instrument Data sheet & Catalogs
CLIENT: Gachsaran Polymer Industries Company (GPIC) P.O. NO.: GPIC-PT-MA-PO-000-3029 SERVICE: PROPYLENE REFERIGERATION PACKAGE	NO.	BY	APP	DATE	P.O.I.	
	00	N.B	A.M	12.10.25	IFR	

- NOTES:
- 1 SYSTEM DESIGN PRESSURE & TEMPERATURE: FV to 362.5 PSIG 25.0 BarG @ 250 °F 121 °C
-45 °F -43 °C
 - 2 WETTED MATERIAL IS 316L STAINLESS STEEL
 - 3 MATERIAL TEST REPORT TO INCLUDE CHARPY IMPACT TEST PER ASME & ASTM CODES
 - 4 INSTRUMENT SHALL BE SUITABLE FOR ON-SHORE SERVICE
 - 5 CALIBRATION CERTIFICATE REQUIRED NOT REQUIRED
 - 6 CERTIFICATE OF COMPLIANCE REQUIRED NOT REQUIRED
 - 7 316SS NAMEPLATE REQUIRED NOT REQUIRED
 - 8 CUSTOMER SPECIFICATION: N/A & N/A
 - 9 C TO C DISTA 48 inches 1,219.2 mm
 - 10 VENT AND DRAIN CONNECTION SHALL BE SUPPLIED WITH BALL VALVES

REQUIREMENTS

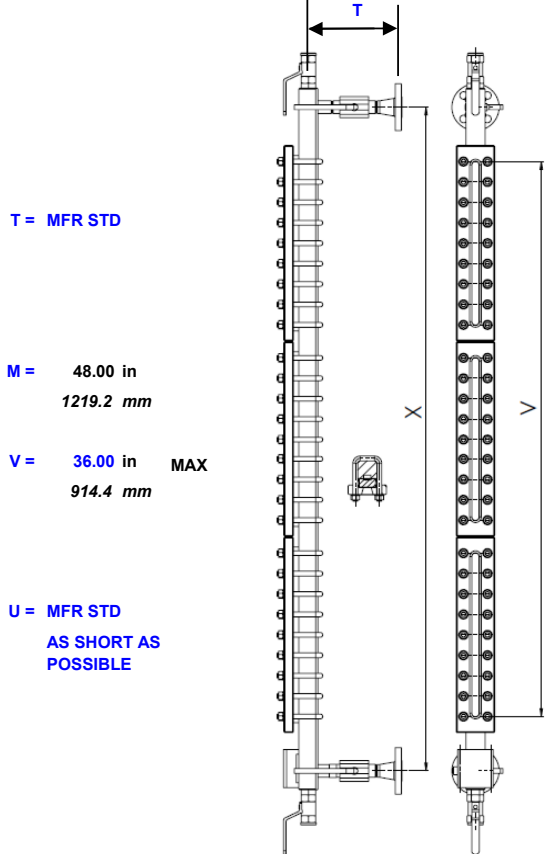

IN-42. It shall be selected. add "EExia"

GENERAL	1	Tag No.	SEE TABLE BELOW		Service:	SEE TABLE BELOW
	2	Qty				
	3	Function	Record <input type="checkbox"/>	Indicate <input checked="" type="checkbox"/>	Control <input checked="" type="checkbox"/>	VIA MCS <input type="checkbox"/> Blind <input type="checkbox"/> Trans <input checked="" type="checkbox"/> Other
	4	Case	Mfr. Std. <input checked="" type="checkbox"/>	Nom. Size	Color :	<input type="checkbox"/> Other NOTE 2
	5	Mounting	Flush <input type="checkbox"/>	Surface <input checked="" type="checkbox"/>	Yoke <input type="checkbox"/>	Other
	6	Enclosure Class	Gen. Purpose <input type="checkbox"/>	Weather Proof <input type="checkbox"/>	Explosion Proof <input type="checkbox"/>	Other <input checked="" type="checkbox"/> IIB-T5 - ZONE 2, CL1
	7	Power Supply	117V 60 Hz <input checked="" type="checkbox"/>	Other ac <input type="checkbox"/>	DC <input checked="" type="checkbox"/>	Volts 24 V
	8	Chart	N/A	Strip <input type="checkbox"/> Roll <input type="checkbox"/> Fold <input type="checkbox"/>	Circular <input type="checkbox"/>	Time Marks <input type="checkbox"/>
	9	Chart Drive	N/A	Speed	Power	
	10	Scales	Type: LCD / DIGITAL			
			Range: SEE TABLE BELOW			
XMTR	11	Transmitter Output	4-20 mA <input checked="" type="checkbox"/>	10-50mA <input type="checkbox"/>	21-103 kPa (3-15 psig) <input type="checkbox"/>	Other
			For Receiver, see spec sheet. WIRED TO UCP VIA JUNCTION BOXES (2 WIRE OUTPUT) NOTE 18			
CONTROLLER VIA UCP	12	Control Modes	P = Prop (Gain), 1-Integral (Auto Reset), D = Derivative (Rate)			
			Sub: s = slow, f = fast, if <input type="checkbox"/> Df <input type="checkbox"/> P <input type="checkbox"/> PI <input type="checkbox"/> PD <input type="checkbox"/> PID <input checked="" type="checkbox"/> Is <input type="checkbox"/> Ds <input type="checkbox"/>			
	14	Action	On Measurement Increase, Output: Increases <input type="checkbox"/> Decreases <input type="checkbox"/>			
	15	Auto-Man Switch	None <input type="checkbox"/>	MFR Std <input type="checkbox"/>	Other	
	16	Set Point Adj.	Manual <input type="checkbox"/>	External <input type="checkbox"/>	Remote <input type="checkbox"/>	Other
	17	Manual Reg.	None <input type="checkbox"/>	MFR Std <input type="checkbox"/>	Other	
	18	Output	NOTE 18	4-20 mA <input checked="" type="checkbox"/>	10-50 mA <input type="checkbox"/>	21-103 kPa (3-15 psig) <input type="checkbox"/> Other
ELEMENT	19	Service	Gage Press <input type="checkbox"/>	Vacuum <input type="checkbox"/>	Absolute <input type="checkbox"/>	Differential <input checked="" type="checkbox"/>
	20	Element Type	Diaphragm <input checked="" type="checkbox"/> Helix <input type="checkbox"/> Bourdon <input type="checkbox"/> Bellows <input type="checkbox"/> Other			
	21	Material (body)	316SS <input checked="" type="checkbox"/>	Ber Copper <input type="checkbox"/>	Other <input type="checkbox"/>	
	22	Range	Fixed <input type="checkbox"/>	Adj. Range <input checked="" type="checkbox"/>		
			Overrange Protection to: SEE TABLE BELOW Electrical Connection: M20			
	23	Process Data	Press.: Nor.: SEE TABLE BELOW	MAX.:	Element Range:	
	24	Process Conn.	1/4" in NPT <input type="checkbox"/>	1/2" in NPT (F) <input checked="" type="checkbox"/>	Other: 2"-300# ANSI RF FLG	
			Location: Bottom: <input checked="" type="checkbox"/>	Back <input type="checkbox"/>	Other	
	25	Alarm Switches	Quantity:	Form	Rating	
	26	Function	Press. <input checked="" type="checkbox"/>	Deviation <input type="checkbox"/>	Contacts	On Icr. Meas.
OPTIONS	27	Options	Filter Reg. <input type="checkbox"/>	Sup. Gage <input type="checkbox"/>	Output Gage <input type="checkbox"/>	Charts
			Diaphragm Seal <input type="checkbox"/>	Type	m	Bot. Bowl
			Conn. Capillary:			Mtl.
			Other			
AREA CLASSIFICATION			IEC <input checked="" type="checkbox"/>	ZONE 1, EExi IIB-T5	IP-66	Agency Approval: ATEX

IN-43. "EExia"

Item	Qty	Tag No.	Pressure in (mm)		Operating Pressure PSIG / BarG		Calibration mA in (mm) NOTE 23		Manufacturer/ Model no.	Service
			Range	Over	Min	Max	4	20		
A	1	LT-61151 CHILLER	0.00 to 116.9 0 to 2,969	2000 137.9	22.5 1.55	25.9 1.79	0 0.00 0%	107.4 2,718.2 100%		PROPYLENE REFRIGERANT SYNTHETIC OIL
B										
C										

	LEVEL TRANSMITTER CONTROL DEVICES				Document No:	VD-GPIC-MA-3029-3029-0038-00
					Document Title:	Instrument Data sheet & Catalogs
CLIENT: Gachsaran Polymer Industries Company (GPIC) P.O. NO.: GPIC-PT-MA-PO-000-3029 SERVICE: PROPYLENE REFERIGERATION PACKAGE	NO.	BY	APP	DATE	P.O.I.	
	00	N.B	A.M	12.10.25	IFR	

- Notes:
- 1 SYSTEM DESIGN PRESSURE & TEMPERATURE: FV to 362.5 PSIG 25.0 BarG @ 250 °F 121 °C
-45 °F -43 °C
 - 2 NORMAL OPERATING CONDITIONS ARE: 22.5 PSIG 1.55 BarG @ -10.9 °F -23.82 °C
 - 3 TRANSMITTER ELECTRICAL HOUSING MUST BE POLYURETHANE COVERED ALUMINUM
 - 4 REFERENCE ACCURACY: +/- 0.1 % OF FULL SCALE & +/- 0.15 % GUARRANTEED STABILITY OVER FIVE YEARS
 - 5 INSTRUMENT SHALL BE SUITABLE FOR MA **IN-44. "EExia"** ENVIRONMENT
 - 6 CALIBRATION CERTIFICATE REQUIRED NOT REQUIRED
 - 7 HARD COPY OF IIEC-79, EExi IIB-T5 CERTIFICATE REQUIRED NOT REQUIRED
 - 8 MATERIAL TEST REPORT REQUIRED NOT REQUIRED
 - 9 CUSTOMER SPECIFICATION: N/A , N/A & N/A
 - 10 ALL DOCUMENTS TO BE SUBMITTED IN BOTH HARD AND ELECTRONIC FORMAT
 - 11 INDICATOR TO SHOW PERCENTAGE
 - 12 AUSTENSIC 316 SS BOLTS REQUIRED
 - 13 NAMEPLATE TO BE MOUNTED TO TOP FLANGE
 - 14 HIGH PRESSURE SIDE, REMOTE MOUNT SEAL, PROCESS CONNECTION IS 2"-300# ANSI RF FLG.
 - 15 LIQUID DENSITY : 36.05 LB/FT3 579 KG/M3
 - 16 LOW PRESSURE SIDE, PROCESS CONNECTION 2"-300# ANSI RF FLG
 - 17 LCD METER WITH POLYURETHANE COVERED ALUMINUM COVER REQUIRED
 - 18 "SMART" ELECTRONIC TRANSMITTERS WITH "HART PROTOCOL" COMMUNICATION SHALL BE SUITABLE OVER RANGE OF APPLICATION
 - 19 ELECTRICAL CLASS CERTIFICATION SHALL BE SHOWN ON A DIE-STAMPED STAINLESS STEEL TAG PERMANENTLY ATTACHED TO THE DEVICE
 - 20 ELECTRICAL CONNECTION: M20
 - 21 REFRIGERANT IS PROPYLENE WITH OPERATING CONDITIONS SHOWN IN TABULATION
 - 22 C TO C DISTANCE BETWEEN NOZZLES THAT COVERS THE TRANSMITTER CALIBRATION RANGE IS: 107.44 inches 2,718.2 mm
 - 23 IT IS THE RESPONSIBILITY OF THE SUPPLIER TO ASSURE THAT THE FLOATS FIT INSIDE THE CHAMBER
 - 24 TRANSMITTER ORIENTATION SHALL AS PER SHOWN PER BELOW SNAPSHOT CALLED "ACTUAL DESIGN"



REQUIREMENTS

X = 11.5 in
292.1 mm

T = MFR STD

M = 107.44 in
2728.91 mm

U = MFR STD
AS SHORT AS POSSIBLE

Z = 1 in
25.4 mm

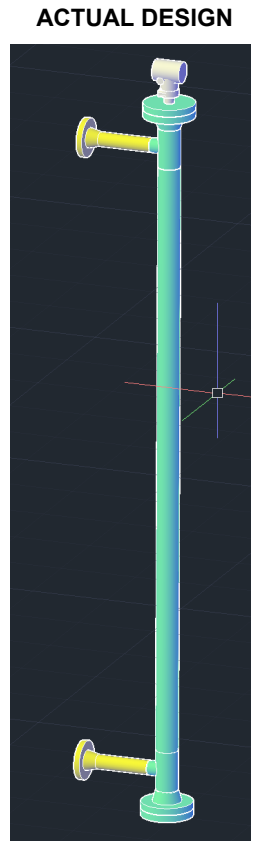

CLIENT: Gachsaran Polymer Industries Company (GPIC)
P.O. NO.: GPIC-PT-MA-PO-000-3029
SERVICE: PROPYLENE REFERIGERATION PACKAGE

IN-45. It shall be selected. add "EExia"

GENERAL	1	Tag No.	SEE TABLE BELOW		Service: SEE TABLE BELOW
	2	Qty			
	3	Function	Record <input type="checkbox"/> Indicate <input checked="" type="checkbox"/> Control <input type="checkbox"/>	VIA MCS Blind <input type="checkbox"/> Trans <input checked="" type="checkbox"/> Other	
	4	Case	Mfr. Std. <input checked="" type="checkbox"/> Nom. Size	Color: <input type="checkbox"/> Other NOTE 2	
	5	Mounting	Flush <input type="checkbox"/> Surface <input checked="" type="checkbox"/>	Yoke <input type="checkbox"/> Other	
	6	Enclosure Class	Gen. Purpose <input type="checkbox"/> Weather Proof <input type="checkbox"/>	Explosion Proof <input type="checkbox"/>	
	7	Power Supply	117V 60 Hz <input checked="" type="checkbox"/> Other ac <input type="checkbox"/>	DC <input checked="" type="checkbox"/> Volts 24 V	
	8	Chart	N/A	Strip <input type="checkbox"/> Roll <input type="checkbox"/> Fold <input type="checkbox"/> Circular <input type="checkbox"/> Time Marks <input type="checkbox"/>	
	9	Chart Drive	N/A	Speed	
	10	Scales	Type: LCD / DIGITAL		
			Range: SEE TABLE BELOW		
XMTR	11	Transmitter Output	4-20 mA <input checked="" type="checkbox"/> 10-50mA <input type="checkbox"/> 21-103 kPa (3-15 psig) <input type="checkbox"/> Other	For Receiver, see spec sheet. WIRED TO UCP VIA JUNCTION BOXES (2 WIRE OUTPUT) NOTE 18	
CONTROLLER	12	Control Modes	P = Prop (Gain), I = Integral (Auto Reset), D = Derivative (Rate)		
VIA N/A			Sub: s = slow, f = fast, If <input type="checkbox"/> Df <input type="checkbox"/> P <input type="checkbox"/> PI <input type="checkbox"/> PD <input type="checkbox"/> PID <input type="checkbox"/> Is <input type="checkbox"/> Ds <input type="checkbox"/>		
	14	Action	On Measurement increase, Output: Increases <input type="checkbox"/> Decreases <input type="checkbox"/>		
	15	Auto-Man Switch	None <input type="checkbox"/> MFR Std <input type="checkbox"/> Other		
	16	Set Point Adj.	Manual <input type="checkbox"/> External <input type="checkbox"/> Remote <input type="checkbox"/> Other		
	17	Manual Reg.	None <input type="checkbox"/> MFR Std <input type="checkbox"/> Other		
	18	Output	NOTE 18 4-20 mA <input type="checkbox"/> 10-50 mA <input type="checkbox"/> 21-103 kPa (3-15 psig) <input type="checkbox"/> Other		
ELEMENT	19	Service	Gage Press <input type="checkbox"/> Vacuum <input type="checkbox"/> Absolute <input type="checkbox"/> Differential <input checked="" type="checkbox"/>		
	20	Element Type	Diaphragm <input checked="" type="checkbox"/> Helix <input type="checkbox"/> Bourdon <input type="checkbox"/> Bellows <input type="checkbox"/> Other		
	21	Material (body)	316SS <input checked="" type="checkbox"/> Ber Copper <input type="checkbox"/> Other <input type="checkbox"/>		
	22	Range	Fixed <input type="checkbox"/> Adj. Range <input checked="" type="checkbox"/>		
			Overrange Protection to: SEE TABLE BELOW Electrical Connection: M20		
	23	Process Data	Press.: Nor.: SEE TABLE BELOW MAX.: Element Range:		
	24	Process Conn.	1/4" in NPT <input type="checkbox"/> 1/2" in NPT (F) <input checked="" type="checkbox"/> Other: 2"-300# ANSI RF FLG		
			Location: Bottom: <input checked="" type="checkbox"/> Back <input type="checkbox"/> Other		
	25	Alarm Switches	Quantity: Form Rating		
	26	Function	Press. <input checked="" type="checkbox"/> Deviation <input type="checkbox"/> Contacts On lcr. Meas.		
OPTIONS	27	Options	Filter Reg. <input type="checkbox"/> Sup. Gage <input type="checkbox"/> Output Gage <input type="checkbox"/> Charts		
			Diaphragm Seal <input type="checkbox"/> Type Bot. Bowl		
			Conn. Capillary: IN-46. "EExia" Mtl.		
			Other		
AREA CLASSIFICATION			IEC <input checked="" type="checkbox"/> ZONE 1, EExi IIB-T5 IP-66 Agency Approval: ATEX		

Item	Qty	Tag No.	Pressure in (mm)		Operating Pressure PSIG / BarG		Calibration mA in (mm) NOTE 23		Manufacturer/ Model no.	Service
			Range	Over	Min	Max	4	20		
A	1	LT-61131 OIL SEPARATOR	0.00 to 57.4 0 to 1,459	2000 137.9	275.6 19.0	289.1 19.9	0 0.00 0%	48.0 1,214.4 100%		NATURAL GAS & SYNTHETIC OIL
B										
C										

	LEVEL TRANSMITTER INDICATOR DEVICES				Document No:	VD-GPIC-MA-3029-3029-0038-00
					Document Title:	Instrument Data sheet & Catalogs
CLIENT: Gachsaran Polymer Industries Company (GPIC) P.O. NO.: GPIC-PT-MA-PO-000-3029 SERVICE: PROPYLENE REFRIGERATION PACKAGE	NO.	BY	APP	DATE	P.O.I.	
	00	N.B	A.M	12.10.25	IFR	

- Notes:
- 1 SYSTEM DESIGN PRESSURE & TEMPERATURE: FV to 362.5 PSIG 25.0 BarG @ 250 °F 121 °C
-49 °F -45 °C
 - 2 NORMAL OPERATING CONDITIONS ARE: FV to 59.6 PSIG 4.1 BarG @ 158 °F 70 °C FOR ITEMS: 1
158 °F 70 °C FOR ITEMS:
 - 3 TRANSMITTER ELECTRICAL HOUSING MUST BE POLYURETHANE COVERED ALUMINUM
 - 4 REFERENCE ACCURACY: +/- 0.075 % OF FULL SCALE & +/- 0.15 % GUARRANTEED STABILITY OVER FIVE YEARS
 - 5 INSTRUMENT SHALL BE SUITABLE FOR M **IN-47. "EExia"** ENVIRONMENT
 - 6 CALIBRATION CERTIFICATE REQUIRED NOT REQUIRED
 - 7 HARD COPY OF IEC-79, EExi IIB-T5 CERTIFICATE REQUIRED NOT REQUIRED
 - 8 MATERIAL TEST REPORT REQUIRED NOT REQUIRED
 - 9 CUSTOMER SPECIFICATION: N/A & N/A
 - 10 ALL DOCUMENTS TO BE SUBMITTED IN BOTH HARD AND ELECTRONIC FORMAT
 - 11 INDICATOR TO SHOW PERCENTAGE
 - 12 AUSTENSIC 316 SS BOLTS REQUIRED
 - 13 NAMEPLATE TO BE MOUNTED TO TOP FLANGE
 - 14 HIGH PRESSURE SIDE, PROCESS CONNECTION IS 2"-300# ANSI RF FLG.
 - 15 LIQUID DENSITY : 65 LB/FT3 1044 KG/M3
 - 16 LOW PRESSURE SIDE, PROCESS CONNECTION 2"-300# ANSI RF FLG
 - 17 LCD METER WITH POLYURETHANE COVERED ALUMINUM COVER REQUIRED
 - 18 "SMART" ELECTRONIC TRANSMITTERS WITH "HART PROTOCOL" COMMUNICATION SHALL BE SUITABLE OVER RANGE OF APPLICATION
 - 19 ELECTRICAL CLASS CERTIFICATION SHALL BE SHOWN ON A DIE-STAMPED STAINLESS STEEL TAG PERMANENTLY ATTACHED TO THE
 - 20 DEVICE ELECTRICAL CONNECTION: M20
 - 21
 - 22 LIQUID MEDIA IS PAG OIL WITH OPERATING CONDITIONS SHOWN IN TABULATION
 - 23 DISTANCE BETWEEN NOZZLES THAT COVERS THE TRANSMITTER CALIBRATION RANGE IS: 48.00 inches 1,214.4 mm
 - 24 IT IS THE RESPONSIBILITY OF THE SUPPLIER TO ASSURE THAT THE FLOATS FIT INSIDE THE CHAMBER
 - 25 TRANSMITTER ORIENTATION SHALL AS PER SHOWN PER BELOW SNAPSHOT CALLED "ACTUAL DESIGN"



X = 14.38 in
 365 mm

 T = MFR STD

 M = 48.00 in
 1219 mm

 U = MFR STD
 AS SHORT AS
 POSSIBLE

 Z = 1 in
 25.4 mm

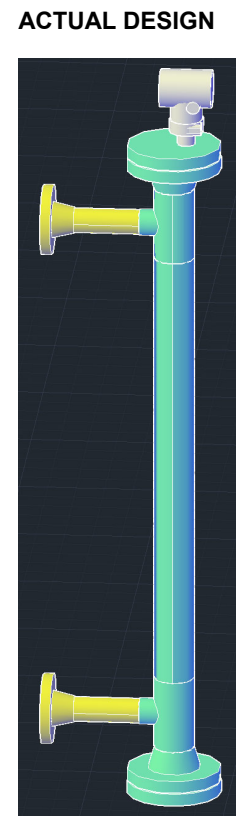
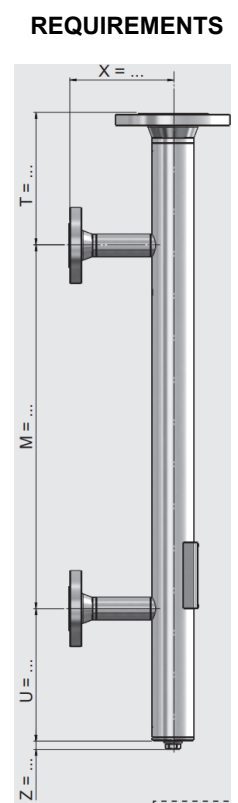

	SIGHT INDICATOR (ROTAMETER)				Document No:	VD-GPIC-MA-3029-3029-0038-00
					Document Title:	Instrument Data sheet & Catalogs
CLIENT: Gachsaran Polymer Industries Company (GPIC) P.O. NO.: GPIC-PT-MA-PO-000-3029 SERVICE: PROPYLENE REFRIGERATION PACKAGE	NO.	BY	APP	DATE	P.O.I.	
	00	N.B	A.M	12.10.25	IFR	

Item No.	A				B				C	
Tag No.	SI-701-O-4 RECEIVER				FG-61131 OIL DEPARATOR					
Connections										
Inlet	3/4"-300# ANSI RF				1-1/2"-300# ANSI RF					
Outlet	3/4"-300# ANSI RF				1-1/2"-300# ANSI RF					
Rating	300#				300#					
Drawing										
P&ID	VD-GPIC-MA-3029-3029-0015				VD-GPIC-MA-3029-3029-0015					
Type										
Mounting	IN-LINE HORIZONTALLY MOUNTED				IN-LINE HORIZONTALLY MOUNTED					
Construction	BULL'S EYE TYPE (DUAL WINDOW)				BULL'S EYE TYPE (DUAL WINDOW)					
Type	ROTOR				ROTOR					
Material										
Body	STAINLESS STEEL - A351-CF8				STAINLESS STEEL - A351-CF8					
Glass	TEMPERED BOROSILICATE GLASS (SHATTER PROOF)				TEMPERED BOROSILICATE GLASS (SHATTER PROOF)					
Seal/Elastomer	TEFLON				TEFLON					
Bolts / Nuts	SA193-B7 / SA194-2H				SA193-B8 / SA194-8					
Service										
Media	SYNTHETIC OIL / PROPYLENE REFRIGERANT				SYNTHETIC OIL / PROPYLENE REFRIGERANT					
Phase	LIQUID / VAPOR				GAS / VAPOR					
Operating Conditions										
Pressure	270.2	PSIG	18.6	BarG	270.7	18.67	BarG			
Temperature	116.96	°F	47.2	°C	171	77.2	°C			
Manufacture										
Model	FS03-02-02-04 (3/4")				FS03-02-02-04 (3/4")					
Quantity	2				2					

IN-48. Range of flow shall be specified.

- Notes:
- SYSTEM DESIGN PRESSURE & TEMPERATURE: FV to 362.5 PSIG 25.0 BarG @ 250 °F 121 °C
 MINIMUM DESIGN TEMPERATURE -45 °F -43 °C FOR: 3
 -20 °F -29 °C FOR: 1
 - WETTED MATERIAL IS 316 STAINLESS STEEL
 - INSTRUMENT SHALL BE SUITABLE FOR MARINE, SALT LADEN, CORROSIVE ENVIRONMENT
 - CALIBRATION CERTIFICATE REQUIRED NOT REQUIRED
 - CERTIFICATE OF COMPLIANCE REQUIRED NOT REQUIRED
 - 316SS NAMEPLATE REQUIRED NOT REQUIRED
 - NACE MR-0175-RATED
 - ALL DOCUMENTS TO BE SUBMITTED IN BOTH HARD AND ELECTRONIC FORMAT
 - BOLTS / NUTS SHALL BE CADMIUM PLATED
 - INDIVIDUAL PART WEIGHT MUST BE CERTIFIED
 - WHERE APPLICABLE, PMI REQUIRED PER SPECIFICATION
 - INSPECTION PER STATED CODES
 - STAINLESS STEEL MATERIAL CAN BE QUOTED IF CARBON STEEL IS NOT AVAILABLE
 - HYDROSTATIC CERTIFICATE REQUIRED FOR ALL VALVES



				SOLENOID VALVE				Document No:	VD-GPIC-MA-3029-3029-0038-00	
								Document Title:	Instrument Data sheet & Catalogs	
				NO.	BY	APP	DATE	P.O.I.		
				00	N.B	A.M	12.10.25	IFR		
CLIENT: Gachsaran Polymer Industries Company (GPIC) P.O. NO.: GPIC-PT-MA-PO-000-3029 SERVICE: PROPYLENE REFERIGERATION PACKAGE										
GENERAL	0	Item No.	A							
	1	Tag No.	LOAD	XY-61112	&	XY-61122				
		UNLOAD	XY-61111	&	XY-61121					
	2	Service	AIR							
	3	Line No. / Vessel No.	COMPRESSOR LOADING / UNLOADING							
4	Valve No.	DIRV-61111 DIRV-61111								
VALVE BODY	5	Type	3 WAY DIRECT ACTING w/ QUICK EXHAUST							
	6	Size - Body / Port	1/4" / 3							
	7	Rating & Type Connection	NPT							
	8	Material - Body	316 STAINLESS STEEL							
	9	Material - Disc (Trim)	BUNA (HIGH NITRILE)							
	10	Material-Diaphragm / Coil	EPOXY MOLDED							
	11	Operation - Direct/Pilot	DIRECT							
	12	Packless or Type Packed	----							
	13	Manual Reset Lever	----							
	14	Manual Operator(override)	INCLUDED							
	15									
16										
WHEN DE-ENERGIZE	17	2-Ways Valve Opens/Close	---							
	18	3-Way (NOTE 10)	YES							
	19	Vent Port Opens/Close	OPENS							
	20	Pressure Port Opens/Close	CLOSES							
	21	4-Way	----							
	22	Pressure to Cyl. 1/ Cyl. 2	----							
	23	Exh. from Cyl. 1/ Cyl. 2	----							
	24									
SOLENOID	26	Enclosure	IEC-79, Eex(d) IIC-T6 IP66 (NEMA-4X)							
	27	Voltage/Hz	24 VDC (LOW POWER OPERATOR)							
	28	Style of Coil	CL. "H" HERMETICALLY SEALED HIGH TEMP.							
	29	Single or Double Coil	SINGLE							
	30	Area Classification	IEC-79, ZONE 2, GROUP IIB, T3							
	31	Cable Entry	M20 x 1.5 mm							
	32	Fluid	AIR							
SERVICE CONDITION	33	Qty., Max	8	SCFM	12.7	S M3/HR				
	34	Operating Differential Min/Max	10	/	15	PSID	0.7	/	1.03 BarD	
	35	Allow. Differential Min/Max	20	/	150	PSID	1.4	/	10.3 BarD	
	36	Temperature Norm/Max	70	/	100	°F	21	/	37.8 °C	
	37	Operating Specific Gravity	1.0							
	38	Operating Viscosity	----							
	39	Required Cv	0.200							
	40	Valve Cv / Orifice	0.8 /							
	41									
	42	Agency Approval	ATEX							
	43									
44										
45	Manufacturer	ASCO								
46	Model No.	WSNFET8327B302MS 24VDC					MOUNTING BRACKET NO.: C133441			
47	QTY	4								
NOTES:	1	SYSTEM DESIGN PRESSURE & TEMPERATURE: 150 PSIG 10 BarG @ 300 °F 149 °C								
	2									
	3	INSTRUMENT SHALL BE SUITABLE FOR MARINE, SALT LADEN, CORROSIVE ENVIRONMENT								
	4	CALIBRATION CERTIFICATE		<input type="checkbox"/>	REQUIRED		<input checked="" type="checkbox"/>	NOT REQUIRED		
	5	CERTIFICATE OF COMPLIANCE		<input checked="" type="checkbox"/>	REQUIRED		<input type="checkbox"/>	NOT REQUIRED		
	6	HARD COPY OF IEC-79, EEXD IIC-T6 CERTIFICATE		<input checked="" type="checkbox"/>	REQUIRED		<input type="checkbox"/>	NOT REQUIRED		
	7	AREA CLASSIFICATION: IEC-79, ZONE 2, GROUP IIB, T3								
	8	MANUFACTURER CALCULATION / SIZING SHEET		<input type="checkbox"/>	REQUIRED		<input checked="" type="checkbox"/>	NOT REQUIRED		
	9	STAINLESS STEEL NAMEPLATE (316)		<input checked="" type="checkbox"/>	REQUIRED		<input type="checkbox"/>	NOT REQUIRED		
	10	COILS SHALL BE FITTED WITH SURGE SUPPRESSION DIODES.								
	11	SOLENOID VALVE POWER CONSUMPTION SHALL BE LESS THAN 10 WATTS.								
	12	BUG SCREENS SHALL BE INSTALLED ON EXHAUST								
	13	LEADS TO BE TERMINATED IN A CONDUIT BOX SUITABLE FOR AREA CLASSIFICATION.								
	14	ALL DOCUMENTS TO BE SUBMITTED IN BOTH HARD AND ELECTRONIC FORMAT								
	15	INDIVIDUAL PART WEIGHT MUST BE CERTIFIED								

IN-49. Please recheck.

	SOLENOID VALVE (CAPACITY CONTROL)				Document No:	VD-GPIC-MA-3029-3029-0038-00	
					Document Title:	Instrument Data sheet & Catalogs	
		NO.	BY	APP	DATE	P.O.I.	
		00	N.B	A.M	12.10.25	IFR	
CLIENT: Gachsaran Polymer Industries Company (GPIC) P.O. NO.: GPIC-PT-MA-PO-000-3029 SERVICE: PROPYLENE REFERIGERATION PACKAGE							

IMI MAXSEAL **ICO4S 2/2, 3/2 or 5/2 poppet valves**
 electromagnetic actuated, directly controlled

- > Port size: 1/4" ... 3/4" (ISO G/NPT) or manifold version
- > Direct acting solenoid valve for the control of hydraulic or pneumatic equipment
- > High flow
- > Up to 414 bar inlet pressure
- > Reliable and long life, ideal for a one time installation
- > Certifications: ATEX, CSA, CSA, TR CU, NEPSI, KOSHA, IECEX, FM, CRN, CCOE IN-METRO
- > Environmental protection; NEMA 4X, IP66/X8

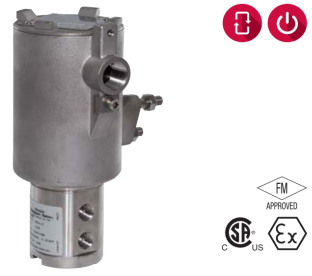

Technical features

Medium: Hydraulic and pneumatic – customer to specify and confirm compatibility
Operation: Direct solenoid operated poppet valves
Mounting position: Solenoid vertical

Flow: 0,8 Cv (11,5 Kv) ... 5,0 Cv (72,0 Kv)
Port size: 1/4 NPT, 1/2 NPT, G1/4, G1/2 or manifold version
Operating pressure: 0 ... 20 bar (0 ... 290 psi)
 0 ... 50 bar (0 ... 725 psi)
 0 ... 207 bar (0 ... 3002 psi)
 0 ... 414 bar (0 ... 6004 psi)

Temperature:
 Media: -20 ... +90°C (-4 ... +194°F)
 Options to -60°C (-76°F) available on request
 Ambient: See table on page 2
 Air supply must be dry enough to avoid ice formation at temperatures below +2°C (+35°F).

Materials:
 Valve body, trim, coil housing and top cover: stainless steel 1.4404 (316 L)
 Other trim and body materials available
 O-rings seats & seals: high NBR
 Other seal materials available on request

IMI MAXSEAL **ICO4S 2/2, 3/2 or 5/2 poppet valves**
 electromagnetic actuated, directly controlled

Option selector **Y1*****S**

<table border="1"> <thead> <tr> <th>Operating pressure</th> <th>Substitute</th> </tr> </thead> <tbody> <tr><td>0 ... 12 bar (0 ... 175 psi)</td><td>1</td></tr> <tr><td>0 ... 20 bar (0 ... 290 psi)</td><td>2</td></tr> <tr><td>0 ... 50 bar (0 ... 725 psi)</td><td>3</td></tr> <tr><td>0 ... 207 bar (0 ... 3002 psi)</td><td>6</td></tr> <tr><td>0 ... 414 bar</td><td>9</td></tr> </tbody> </table>	Operating pressure	Substitute	0 ... 12 bar (0 ... 175 psi)	1	0 ... 20 bar (0 ... 290 psi)	2	0 ... 50 bar (0 ... 725 psi)	3	0 ... 207 bar (0 ... 3002 psi)	6	0 ... 414 bar	9	<table border="1"> <thead> <tr> <th>Number of ports</th> <th>Substitute</th> </tr> </thead> <tbody> <tr><td>2/2 NC (standard)</td><td>1</td></tr> <tr><td>2/2 NO</td><td>2</td></tr> <tr><td>3/2 NC (universal)</td><td>3</td></tr> <tr><td>5/2</td><td>5</td></tr> </tbody> </table>	Number of ports	Substitute	2/2 NC (standard)	1	2/2 NO	2	3/2 NC (universal)	3	5/2	5	<table border="1"> <thead> <tr> <th>Operation</th> <th>Substitute</th> </tr> </thead> <tbody> <tr><td>Automatic</td><td>A</td></tr> <tr><td>Automatic latching lever</td><td>B</td></tr> <tr><td>Push button manual override</td><td>C</td></tr> <tr><td>Lever manual reset (414 bar only)</td><td>L</td></tr> <tr><td>Lever manual override (414 bar only)</td><td>M</td></tr> <tr><td>Push button manual reset</td><td>P</td></tr> <tr><td>Jack screw manual override</td><td>S</td></tr> <tr><td>Tamper proof manual reset</td><td>T</td></tr> </tbody> </table>	Operation	Substitute	Automatic	A	Automatic latching lever	B	Push button manual override	C	Lever manual reset (414 bar only)	L	Lever manual override (414 bar only)	M	Push button manual reset	P	Jack screw manual override	S	Tamper proof manual reset	T	<table border="1"> <thead> <tr> <th>Port size</th> <th>Substitute</th> </tr> </thead> <tbody> <tr><td>1/4 NPT</td><td>A1</td></tr> <tr><td>G 1/4</td><td>E1</td></tr> <tr><td>1/2 NPT</td><td>A3</td></tr> <tr><td>G 1/2</td><td>E3</td></tr> <tr><td>3/4 NPT</td><td>A5</td></tr> <tr><td>G 3/4</td><td>E5</td></tr> <tr><td>Manifold</td><td>KF</td></tr> </tbody> </table>	Port size	Substitute	1/4 NPT	A1	G 1/4	E1	1/2 NPT	A3	G 1/2	E3	3/4 NPT	A5	G 3/4	E5	Manifold	KF	<table border="1"> <thead> <tr> <th>Voltage</th> <th>Substitute</th> </tr> </thead> <tbody> <tr><td>18/33 V d.c.</td><td>A</td></tr> <tr><td>24 V d.c.</td><td>B</td></tr> <tr><td>48/50 V d.c. (50 V)</td><td>C</td></tr> <tr><td>110 V d.c.</td><td>D</td></tr> <tr><td>125 V d.c.</td><td>E</td></tr> <tr><td>220/240 V d.c. (240 V)</td><td>F</td></tr> <tr><td>24 V a.c.</td><td>G</td></tr> <tr><td>110 V a.c.</td><td>J</td></tr> <tr><td>12 V d.c.</td><td>L</td></tr> <tr><td>220/240 V a.c. (240 V)</td><td>M</td></tr> </tbody> </table>	Voltage	Substitute	18/33 V d.c.	A	24 V d.c.	B	48/50 V d.c. (50 V)	C	110 V d.c.	D	125 V d.c.	E	220/240 V d.c. (240 V)	F	24 V a.c.	G	110 V a.c.	J	12 V d.c.	L	220/240 V a.c. (240 V)	M	<table border="1"> <thead> <tr> <th>Conduit connection</th> <th>Substitute</th> </tr> </thead> <tbody> <tr><td>M20 x 1.5 mm</td><td>1</td></tr> <tr><td>1/2 NPT</td><td>2</td></tr> </tbody> </table>	Conduit connection	Substitute	M20 x 1.5 mm	1	1/2 NPT	2	<table border="1"> <thead> <tr> <th>Seat / seal material</th> <th>Substitute</th> </tr> </thead> <tbody> <tr><td>High Nitrile (standard)</td><td>H</td></tr> <tr><td>FKM</td><td>V</td></tr> </tbody> </table>	Seat / seal material	Substitute	High Nitrile (standard)	H	FKM	V
Operating pressure	Substitute																																																																																															
0 ... 12 bar (0 ... 175 psi)	1																																																																																															
0 ... 20 bar (0 ... 290 psi)	2																																																																																															
0 ... 50 bar (0 ... 725 psi)	3																																																																																															
0 ... 207 bar (0 ... 3002 psi)	6																																																																																															
0 ... 414 bar	9																																																																																															
Number of ports	Substitute																																																																																															
2/2 NC (standard)	1																																																																																															
2/2 NO	2																																																																																															
3/2 NC (universal)	3																																																																																															
5/2	5																																																																																															
Operation	Substitute																																																																																															
Automatic	A																																																																																															
Automatic latching lever	B																																																																																															
Push button manual override	C																																																																																															
Lever manual reset (414 bar only)	L																																																																																															
Lever manual override (414 bar only)	M																																																																																															
Push button manual reset	P																																																																																															
Jack screw manual override	S																																																																																															
Tamper proof manual reset	T																																																																																															
Port size	Substitute																																																																																															
1/4 NPT	A1																																																																																															
G 1/4	E1																																																																																															
1/2 NPT	A3																																																																																															
G 1/2	E3																																																																																															
3/4 NPT	A5																																																																																															
G 3/4	E5																																																																																															
Manifold	KF																																																																																															
Voltage	Substitute																																																																																															
18/33 V d.c.	A																																																																																															
24 V d.c.	B																																																																																															
48/50 V d.c. (50 V)	C																																																																																															
110 V d.c.	D																																																																																															
125 V d.c.	E																																																																																															
220/240 V d.c. (240 V)	F																																																																																															
24 V a.c.	G																																																																																															
110 V a.c.	J																																																																																															
12 V d.c.	L																																																																																															
220/240 V a.c. (240 V)	M																																																																																															
Conduit connection	Substitute																																																																																															
M20 x 1.5 mm	1																																																																																															
1/2 NPT	2																																																																																															
Seat / seal material	Substitute																																																																																															
High Nitrile (standard)	H																																																																																															
FKM	V																																																																																															

	SOLENOID VALVE (CAPACITY CONTROL)				Document No: VD-GPIC-MA-3029-3029-0038-00
					Document Title: Instrument Data sheet & Catalogs
	NO.	BY	APP	DATE	P.O.I.
	00	N.B	A.M	12.10.25	IFR
CLIENT: Gachsaran Polymer Industries Company (GPIC)					
P.O. NO.: GPIC-PT-MA-PO-000-3029					
SERVICE: PROPYLENE REFERIGERATION PACKAGE					

ICO4S 2/2, 3/2 or 5/2 poppet valves
electromagnetic actuated, directly controlled



Dimensions

①

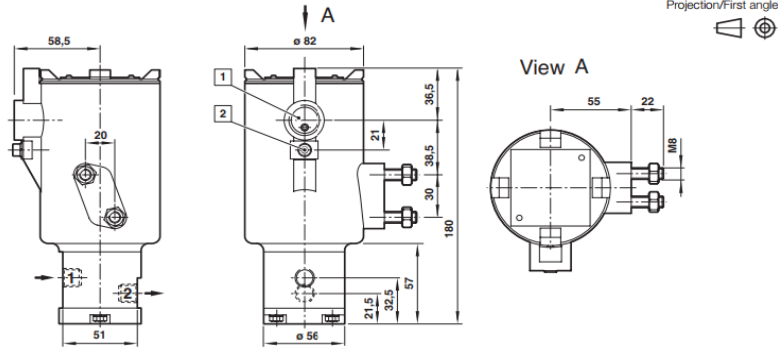

Dimensions in mm
Projection/First angle

②

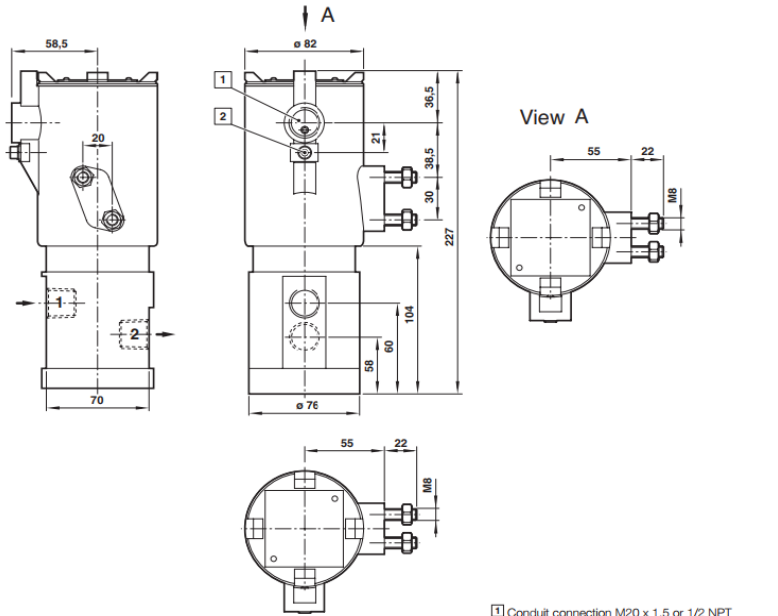

- ① Conduit connection M20 x 1,5 or 1/2 NPT
- ② External earth