

NORTH

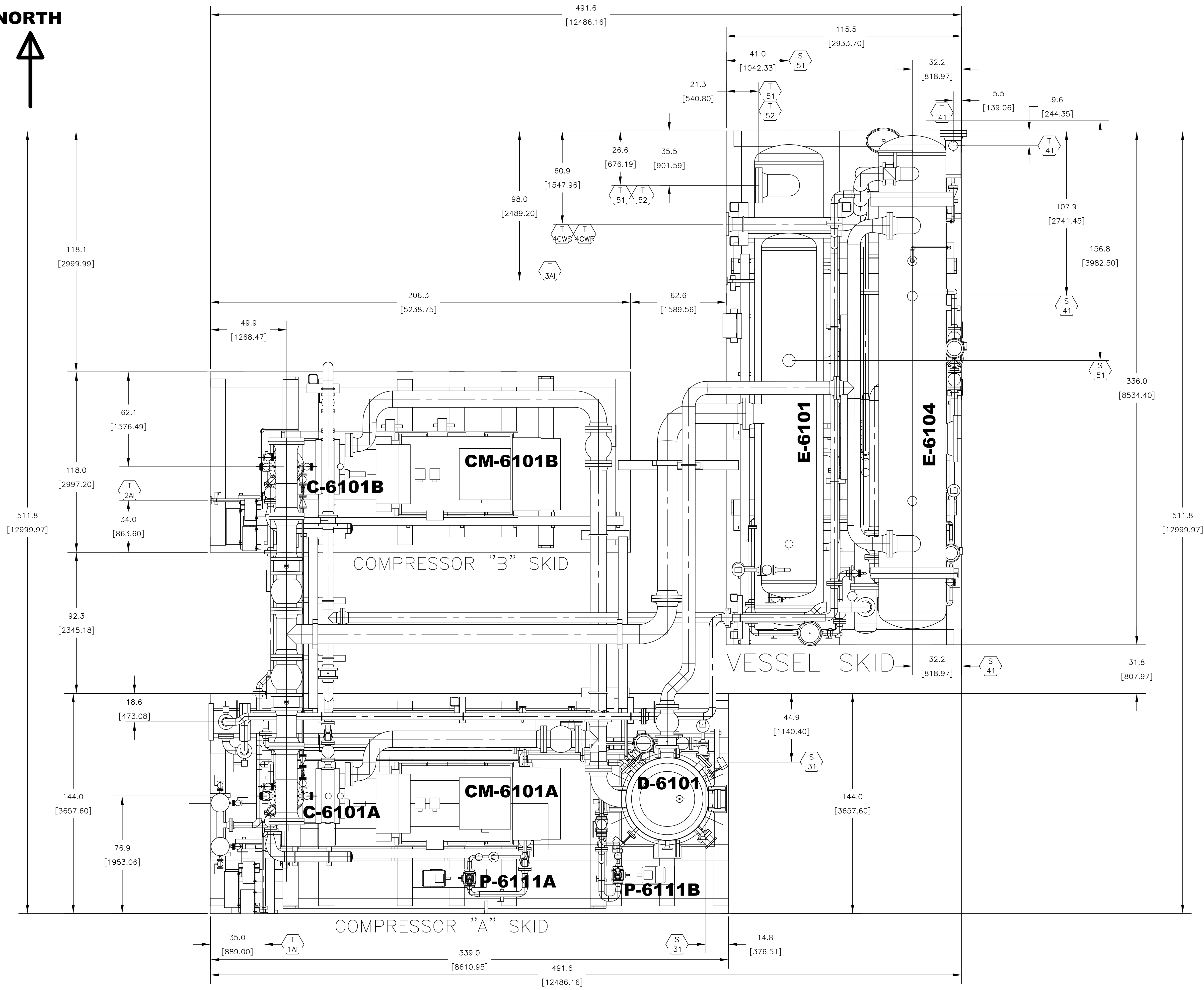

- NOTES:
- FOR OPERATING AND DRY WEIGHTS, REFER TO ULT003-50098.
 - FOR CENTER OF GRAVITY, REFER TO ULT003-50098.
 - FOR DYNAMIC AND STATIC LOADS, REFER TO ULT003-50098.
 - FOR FOUNDATION DETAIL DRAWING, REFER TO ULT003-20021.
 - FOR LIFTING DETAILS, REFER TO ULT003-20011A.
 - FOR SKID INSTALLATION, REFER TO INSTRUCTION AND OPERATIONAL MANUAL ULT003-20092.
 - DIMENSIONS ARE IN INCHES AND MM IN PARENTHESIS.
 - ANCHOR HOLES TOLERANCES ± 0.13 in (± 3.2 mm).
 - BEAM LOCATION TOLERANCES: ± 0.13 in (± 3.2 mm).
 - NON-SKID GRATING UNDER MAINTENANCE AREA IS NOT INCLUDED.
 - SKID FLATNESS SHALL BE 0.0625" (1.6 mm).
 - SURFACE PREPARATION SHALL BE PER PROJECT PAINTING SPECIFICATION.
 - ANCHOR BOLT HOLES SHALL BE WITHIN THE SAME XY AND XZ PLANES WITHIN ± 0.13 in (± 3.2 mm).
 - COMPRESSOR SKIDS SHALL BE GROUTED. GROUT SPECIFICATION AND SELECTION BY OTHER AND SHALL BE SUITABLE TO PAINTING APPLICATION.
 - FOR PIPE NOZZLE LOADS REFER TO DOCUMENT NUMBER VD-GPIC-MA-3029-3029-0062-G (ULT003-20011G)

Code1	<input type="checkbox"/> No Comment/ Approved (Applicable Only for "FOR REVIEW" and "For Approval" Documents) No comment and the document are released for Manufacturing				
Code2	<input type="checkbox"/> No Comment / Approved with Note(s) Vendor/Sub-Contractor shall correct, revise and resubmit the document. The document is released for Manufacturing if changes incorporated.				
Code3	<input type="checkbox"/> Commented Vendor/Sub-Contractor shall correct, revise and resubmit the document by the date specified. The document shall be reissued under the Status of "Revised Issue". All corrected documents shall be resubmitted before starting the Manufacturing Process				
Code4	<input type="checkbox"/> Not Accepted (Rejected) Vendor/Sub-Contractor shall re-work/re-design/re-specify the contents of the document according to the comments/reasons for rejection. All corrected documents shall be resubmitted before starting the manufacturing. Vendor Sub-Contractor shall not proceed with subsequent work of Material Supply or Manufacturing until receiving Code1/Code2 or No Code from PURCHASER. Vendor/Sub-Contractor shall resubmit the document with the same revision within 6 working days after receiving comments				
No Code	<input type="checkbox"/> No Code (Only for "For Information" Documents and "As Built DWGs") Document has been submitted for PURCHASER'S information (I). Consistency, completeness and correctness of document content is in Vendor/Sub-Contractor's responsibility. The above checking result by EIED shall in no way relieve Vendor of any liability, obligation and responsibility out of the purchase order and the mutual agreement in writing				
DATE :					
DEPT :					
Signature :					
CV	PI	EL	IN	ME	MA
ST	BU	PR	SA	HV	TL

02	09.10.2025	IFR	FA	IM	OG
01	16.09.2025	IFR	FA	IM	OG
00	28.06.2025	IFR	FA	IM	OG
REV.	DATE (dd.MM.YY)	Purpose of Issue	Prepared	Checked	Approved

Gacharan Polymer Industries Company
HDPE Plant

PO No.: GPIC-PT-MA-PO-000-3029 SCALE: 3/8":1'

DRAWING TITLE:
General Arrangement Drawing (2D) (Tie-In Points, Skid Dimensions & Orientation, Including Instrument, Junction Box and Local Panel Location Layout & Instrument Cable routing) for Refrigerator Package

DRAWING NO.	VD-GPIC-MA-3029-3029-0062	REV.	SHEET NO.	SIZE
		02	1 OF 9	A1

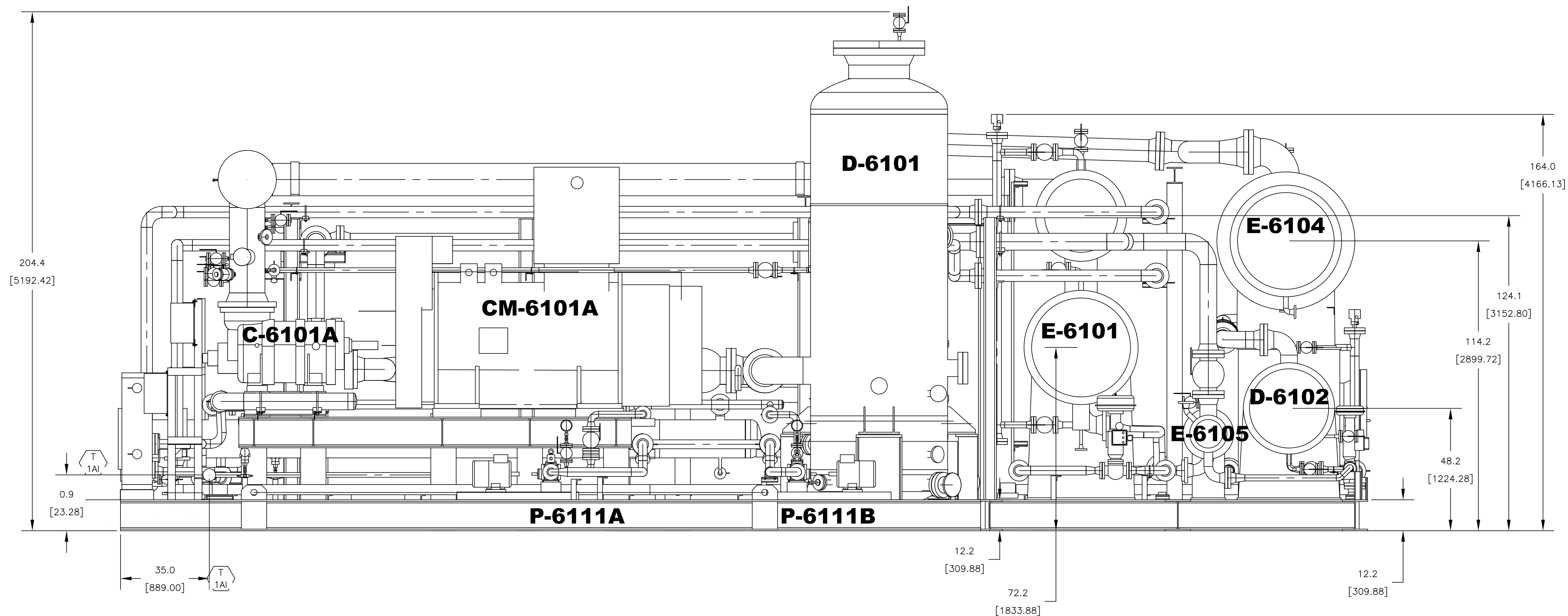

FRONT VIEW

Code1	<input type="checkbox"/> No Comment/ Approved (Applicable Only for "FOR REVIEW" and "For Approval" Documents) No comment and the document are released for Manufacturing				
Code2	<input type="checkbox"/> No Comment / Approved with Note(s) Vendor/Sub-Contractor shall correct, revise and resubmit the document. The document is released for Manufacturing if changes incorporated.				
Code3	<input type="checkbox"/> Commented Vendor/Sub-Contractor shall correct, revise and resubmit the document by the date specified. The document shall be revised under the Status of "R: Revised Issue". All corrected documents shall be resubmitted before starting the Manufacturing Process				
Code4	<input type="checkbox"/> Not Accepted (Rejected) Vendor/Sub-Contractor shall re-work/re-design/re-specify the contents of the document according to the comments/reasons for rejection. All corrected documents shall be resubmitted before starting the manufacturing. Vendor/Sub-Contractor shall not proceed with subsequent work of Material Supply or Manufacturing until receiving Code1/Code2 or No Code from PURCHASER. Vendor/Sub-Contractor shall resubmit the document with the same revision within 6 working days after receiving comments				
No Code	<input type="checkbox"/> No Code (Only for "For Information" Documents and "As Built DWG's") Document has been submitted for PURCHASER's information (I). Consistency, completeness and correctness of document content is in Vendor/Sub-Contractor's responsibility. The above checking result by EIED shall in no way relieve Vendor of any liability, obligation and responsibility out of the purchase order and the mutual agreement in writing				
DATE : DEPT : Signature :					
CV	PR	EL	IN	ME	MA
ST	BU	PR	SA	HV	TL

02	09.10.2025	IFR	FA	IM	OG
01	16.09.2025	IFR	FA	IM	OG
00	28.06.2025	IFR	FA	IM	OG
REV.	DATE (dd.MM.YY)	Purpose of Issue	Prepared	Checked	Approved
		Gachsan Polymer Industries Company HDPE Plant			
PO No.: GPIC-PT-MA-PO-000-3029					SCALE: 1/2":1'
DRAWING TITLE: General Arrangement Drawing (2D) (*Tie-In Points, Skid Dimensions & Orientation, Including Instrument, Junction Box and Local Panel Location Layout & Instrument Cable routing.) for Refrigerator Package					
DRAWING NO. VD-GPIC-MA-3029-3029-0062		REV.	SHEET NO.	SIZE	
		02	2 OF 9	A1	

	A	B	C	D
1			CONNECTION LIST	
2	NO.	LOCATION	DESCRIPTION	SIZE
3	T-1AI	COMPRESSOR SKID-A	INSTRUMENT AIR SUPPLY	1"-150 ANSI RF
4	T-2AI	COMPRESSOR SKID-B	INSTRUMENT AIR SUPPLY	1"-150 ANSI RF
5	T-4AI	VESSEL SKID	INSTRUMENT AIR SUPPLY	1"-150 ANSI RF
6				
7				
8				
9	T-4CWS	VESSEL SKID	OIL COOLER COOLING WATER SUPPLY	8"-300 ANSI RF
10	T-4CWR	VESSEL SKID	OIL COOLER COOLING WATER RETURN	8"-300 ANSI RF
11				
12	T-41	VESSEL SKID	FILTER/DRYER INLET	1-1/2"-300 ANSI RF
13	T-51	VESSEL SKID	CHILLER PROCESS INLET	14"-300 ANSI RF
14	T-52	VESSEL SKID	CHILLER PROCESS OUTLET	14"-300 ANSI RF
15				
16	S-31	COMPRESSOR SKID-A	OIL SEPARATOR PRESSURE SAFETY	4"-300 ANSI RF
17	S-41	VESSEL SKID	CONDENSER PRESSURE SAFETY	3"-300 ANSI RF
18	S-42	VESSEL SKID	RECEIVER PRESSURE SAFETY	4"-300 ANSI RF
19	S-43	VESSEL SKID	ECONOMIZER PRESSURE SAFETY-SHELL	1-1/2"-300 ANSI RF
20	S-44	VESSEL SKID	ECONOMIZER PRESSURE SAFETY-TUBE	1-1/2"-300 ANSI RF
21	S-51	VESSEL SKID	CHILLER PRESSURE SAFETY	3"-300 ANSI RF
22				
23				

EQUIPMENT TAG NUMBER	
TAG NO.	DESCRIPTION
C-6101A	COMPRESSOR
C-6101B	COMPRESSOR
CM-6101A	COMPRESSOR MOTOR
CM-6101B	COMPRESSOR MOTOR
E-6101	CHILLER
E-6102	OIL COOLER
E-6104	CONDENSER
E-6105	ECONOMIZER
D-6101	OIL SEPARATOR
D-6102	RECEIVER
P-6111A/A	OIL PUMPS
PM-6111A/A	OIL PUMP MOTORS

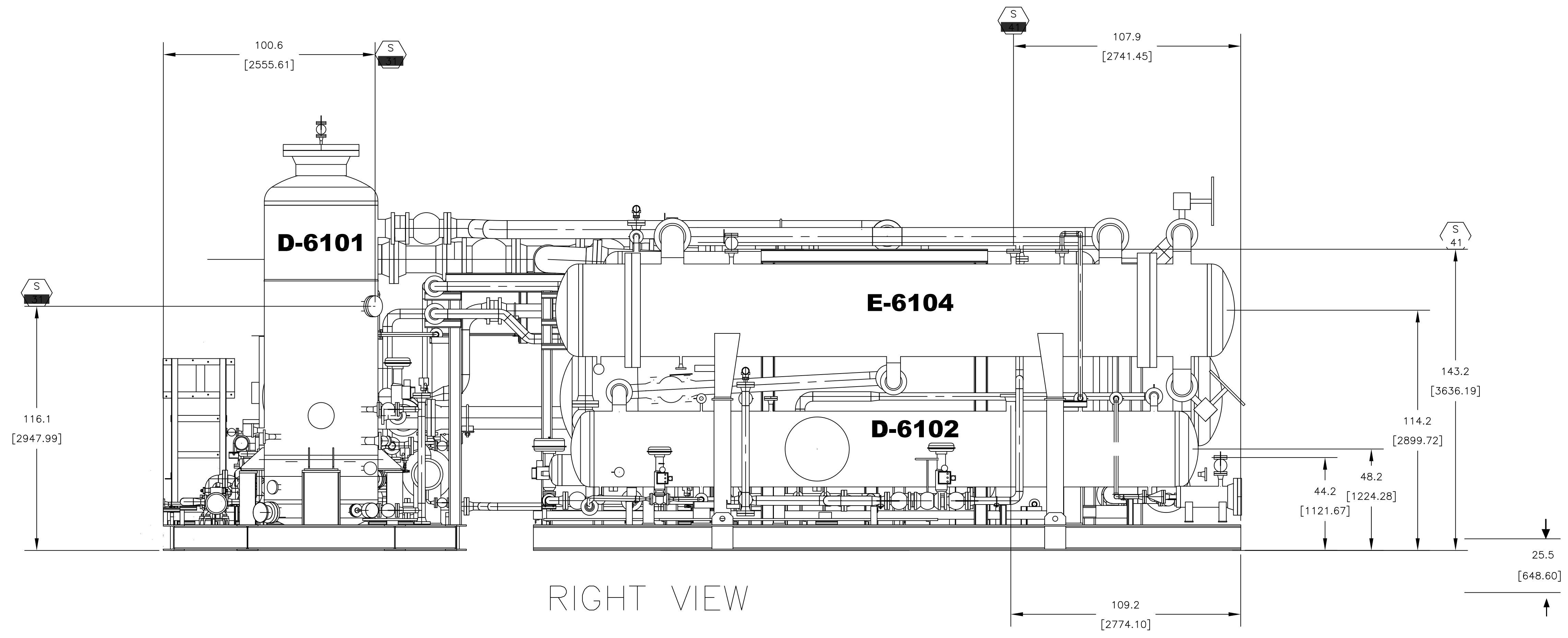

Code1	<input type="checkbox"/> No Comment/ Approved (Applicable Only for "FOR REVIEW" and "For Approval" Documents) No comment and the document are released for Manufacturing
Code2	<input type="checkbox"/> No Comment / Approved with Note(s) Vendor/Sub-Contractor shall correct, revise and resubmit the document. The document is released for Manufacturing if changes incorporated.
Code3	<input type="checkbox"/> Commented Vendor/Sub-Contractor shall correct, revise and resubmit the document by the date specified. The document shall be revised under the Status of "R: Revised Issue". All corrected documents shall be resubmitted before starting the Manufacturing Process
Code4	<input type="checkbox"/> Not Accepted (Rejected) Vendor/Sub-Contractor shall re-work/re-design/re-specify the contents of the document according to the comments/reasons for rejection. All corrected documents shall be resubmitted before starting the manufacturing. Vendor Sub-Contractor shall not proceed with subsequent work of Material Supply or Manufacturing until receiving Code1/Code2 or No Code from PURCHASER. Vendor/Sub-Contractor shall resubmit the document with the same revision within 6 working days after receiving comments
No Code	<input type="checkbox"/> No Code (Only for "For Information" Documents and "As Built DWG's") Document has been submitted for PURCHASER'S information (I). Consistency, completeness and correctness of document content is in Vendor/Sub-Contractor's responsibility.

The above checking result by EIED shall in no way relieve Vendor of any liability, obligation and responsibility out of the purchase order and the mutual agreement in writing

DATE :
DEPT :
Signature :

CV	PI	EL	IN	ME	MA
ST	BU	PR	SA	HV	TL

02	09.10.2025	IFR	FA	IM	OG
01	16.09.2025	IFR	FA	IM	OG
00	28.06.2025	IFR	FA	IM	OG
REV.	DATE (DD.MM.YY)	Purpose of Issue	Prepared	Checked	Approved

PO No.: GPIC-PT-MA-PO-000-3029

DRAWING TITLE:
General Arrangement Drawing (2D) ("Tie-In Points, Skid Dimensions & Orientation, Including Instrument, Junction Box and Local Panel Location Layout & Instrument Cable routing), for Refrigerator Package

DRAWING NO. VD-GPIC-MA-3029-3029-0062



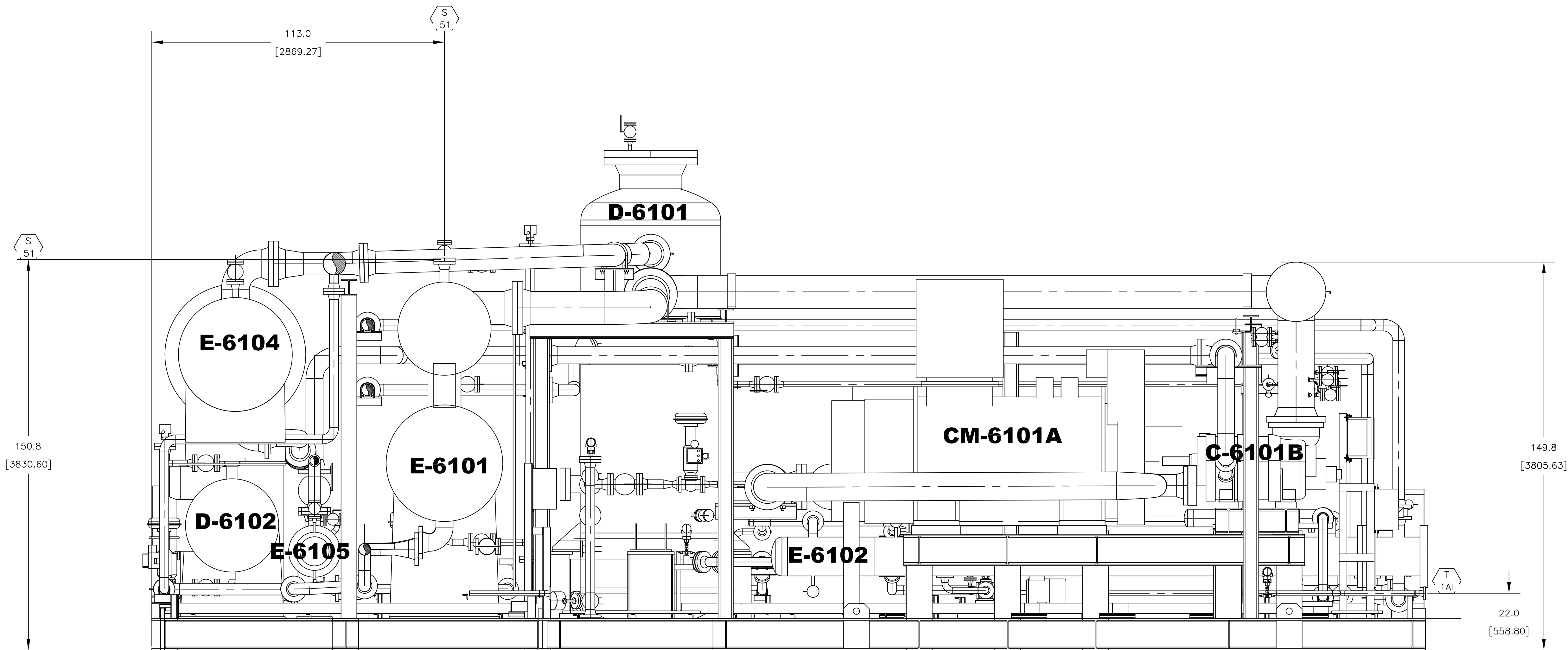

REV.	SHEET NO.	SIZE
02	3 OF 9	A1



BACK VIEW

Code1	<input type="checkbox"/> No Comment / Approved (Applicable Only for "FOR REVIEW" and "For Approval" Documents) No comment and the document are released for Manufacturing				
Code2	<input type="checkbox"/> No Comment / Approved with Note(s) Vendor/Sub-Contractor shall correct, revise and resubmit the document. The document is released for Manufacturing if changes incorporated.				
Code3	<input type="checkbox"/> Commented Vendor/Sub-Contractor shall correct, revise and resubmit the document by the date specified. The document shall be revised under the Status of "R: Revised Issue". All corrected documents shall be resubmitted before starting the Manufacturing Process				
Code4	<input type="checkbox"/> Not Accepted (Rejected) Vendor/Sub-Contractor shall re-work/re-design/re-specify the contents of the document according to the comments/reasons for rejection. All corrected documents shall be resubmitted before starting the manufacturing. Vendor Sub-Contractor shall not proceed with subsequent works of Material Supply or Manufacturing until receiving Code1/Code2 or No Code from PURCHASER. Vendor/Sub-Contractor shall resubmit the document with the same revision within 6 working days after receiving comments				
No Code	<input type="checkbox"/> No Code (Only for "For Information" Documents and "As Built DWGs") Document has been submitted for PURCHASER'S information (I). Consistency, completeness and correctness of document content is in Vendor/Sub-Contractor's responsibility.				
The above checking result by EIED shall in no way relieve Vendor of any liability, obligation and responsibility out of the purchase order and the mutual agreement in writing					
 DATE : DEPT : Signature :					
CV	PI	EL	IN	ME	MA
ST	BU	PR	SA	HV	TL

02	09.10.2025	IFR	FA	IM	OG
01	16.09.2025	IFR	FA	IM	OG
00	28.06.2025	IFR	FA	IM	OG
REV.	DATE (DD.MM.YY)	Purpose of Issue	Prepared	Checked	Approved



Gachasan Polymer Industries Company
HDPE Plant

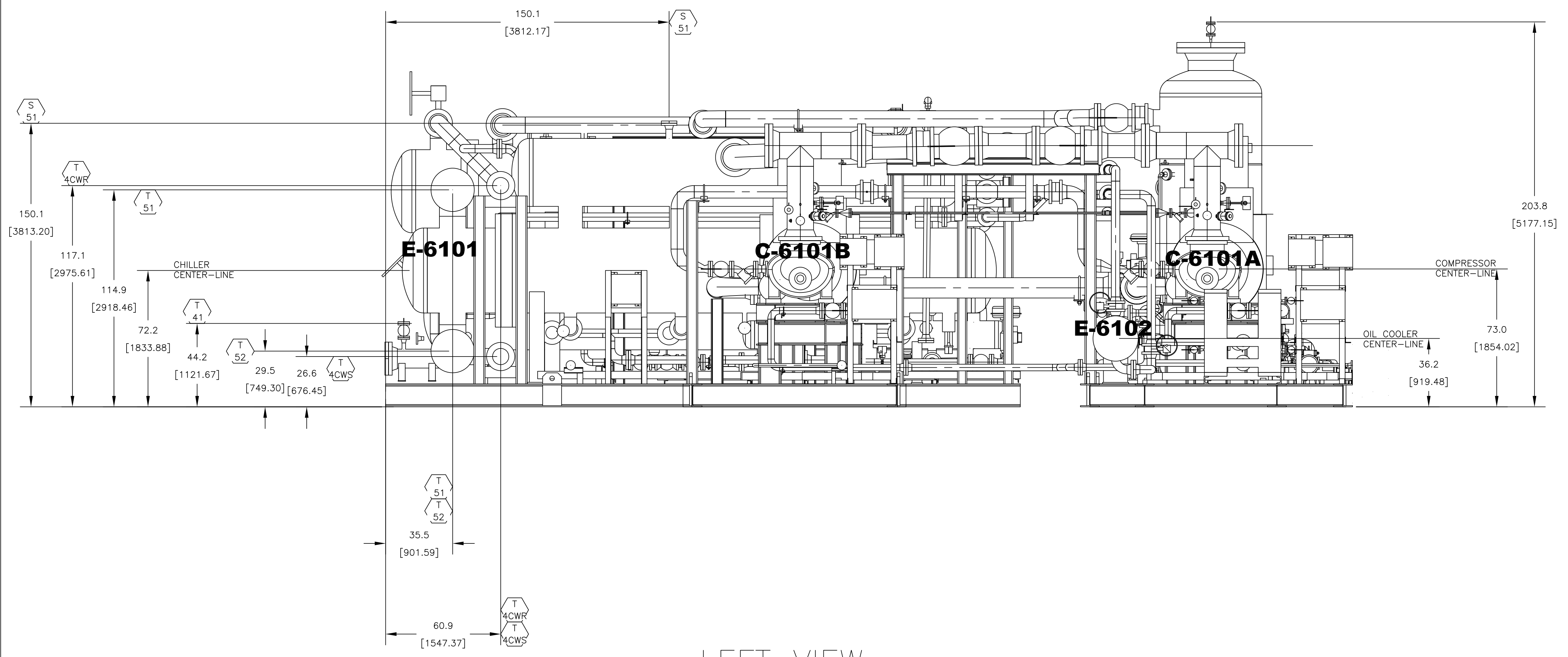

PO No.: GPIC-PT-MA-PO-000-3029 SCALE: 1/2":1'

DRAWING TITLE:
 General Arrangement Drawing (2D) ("Tie-In Points , Skid Dimensions & Orientation, Including Instrument, Junction Box and Local Panel Location Layout & Instrument Cable routing.)
 for Refrigerator Package





DRAWING NO.	REV.	SHEET NO.	SIZE
VD-GPIC-MA-3029-3029-0062	02	4 OF 9	A1



LEFT VIEW

Code1	<input type="checkbox"/> No Comment/ Approved (Applicable Only for "FOR REVIEW" and "For Approval" Documents) No comment and the document are released for Manufacturing				
Code2	<input type="checkbox"/> No Comment / Approved with Note(s) Vendor/Sub-Contractor shall correct, revise and resubmit the document. The document is released for Manufacturing if changes incorporated.				
Code3	<input type="checkbox"/> Commented Vendor/Sub-Contractor shall correct, revise and resubmit the document by the date specified. The document shall be revised under the Status of "R: Revised Issue". All corrected documents shall be resubmitted before starting the Manufacturing Process				
Code4	<input type="checkbox"/> Not Accepted (Rejected) Vendor/Sub-Contractor shall re-work/re-design/re-specify the contents of the document according to the comments/reasons for rejection. All corrected documents shall be resubmitted before starting the manufacturing. Vendor/Sub-Contractor shall not proceed with subsequent work of Material Supply or Manufacturing until receiving Code1/Code2 or No Code from PURCHASER. Vendor/Sub-Contractor shall resubmit the document with the same revision within 6 working days after receiving comments				
No Code	<input type="checkbox"/> No Code (Only for "For Information" Documents and "As Built DWGs") Document has been submitted for PURCHASER'S Information (I). Consistency, completeness and correctness of document content is in Vendor/Sub-Contractor's responsibility. The above checking result by EIED shall in no way relieve Vendor of any liability, obligation and responsibility out of the purchase order and the mutual agreement in writing				
 DATE : DEPT : Signature :					
CV	PI	EL	IN	ME	MA
ST	BU	PR	SA	HV	TL

02	09.10.2025	IFR	FA	IM	OG
01	16.09.2025	IFR	FA	IM	OG
00	28.06.2025	tFR	FA	IM	OG
REV.	DATE (dd.MM.YY)	Purpose of Issue	Prepared	Checked	Approved

 Gachsaran Polymer Industries Company	 Gachsaran Polymer Industries Company HDPE Plant	  DELTA PROCESS EQUIPMENT
---	---	--

PO No.: GPIC-PT-MA-PO-000-3029 SCALE: 3/8":1'

DRAWING TITLE:
General Arrangement Drawing (2D) (Tie-In Points, Skid Dimensions & Orientation, Including Instrument Junction Box and Local Panel Location Layout & Instrument Cable routing.) for Refrigerator Package

DRAWING NO.	VD-GPIC-MA-3029-3029-0062	REV.	SHEET NO.	SIZE
		02	5 OF 9	A1

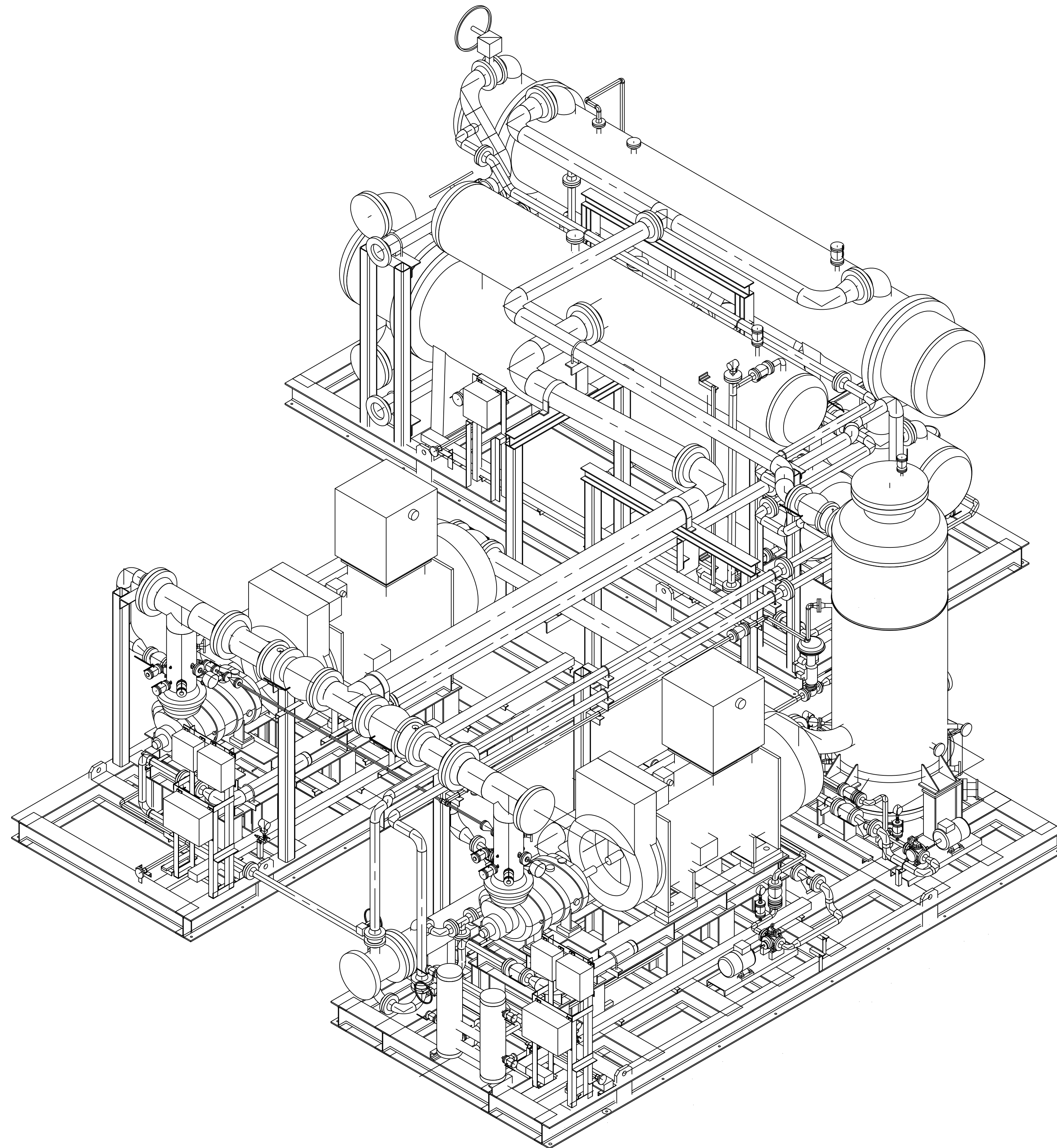

Code1	<input type="checkbox"/> No Comment/ Approved (Applicable Only for "FOR REVIEW" and "For Approval" Documents) No comment and the document are released for Manufacturing
Code2	<input type="checkbox"/> No Comment / Approved with Note(s) Vendor/Sub-Contractor shall correct, revise and resubmit the document. The document is released for Manufacturing if changes incorporated.
Code3	<input type="checkbox"/> Commented Vendor/Sub-Contractor shall correct, revise and resubmit the document by the date specified. The document shall be revised under the Status of "R: Revised Issue". All corrected documents shall be resubmitted before starting the Manufacturing Process
Code4	<input type="checkbox"/> Not Accepted (Rejected) Vendor/Sub-Contractor shall re-work/re-design/re-specify the contents of the document according to the comments/reasons for rejection. All corrected documents shall be resubmitted before starting the manufacturing Vendor Sub-Contractor shall not proceed with subsequent works of Material Supply or Manufacturing until receiving Code1/Code2 or No Code from PURCHASER. Vendor/Sub-Contractor shall resubmit the document with the same revision within 6 working days after receiving comments
No Code	<input type="checkbox"/> No Code (Only for "For Information" Documents and "As Built DWG's") Document has been submitted for PURCHASER's Information (I). Consistency, completeness and correctness of document content is in Vendor/Sub-Contractor's responsibility.

The above checking result by EIED shall in no way relieve Vendor of any liability, obligation and responsibility out of the purchase order and the mutual agreement in writing

EIED

DATE :
DEPT :
Signature :

CV	PI	EL	IN	ME	MA
ST	BU	PR	SA	HV	TL



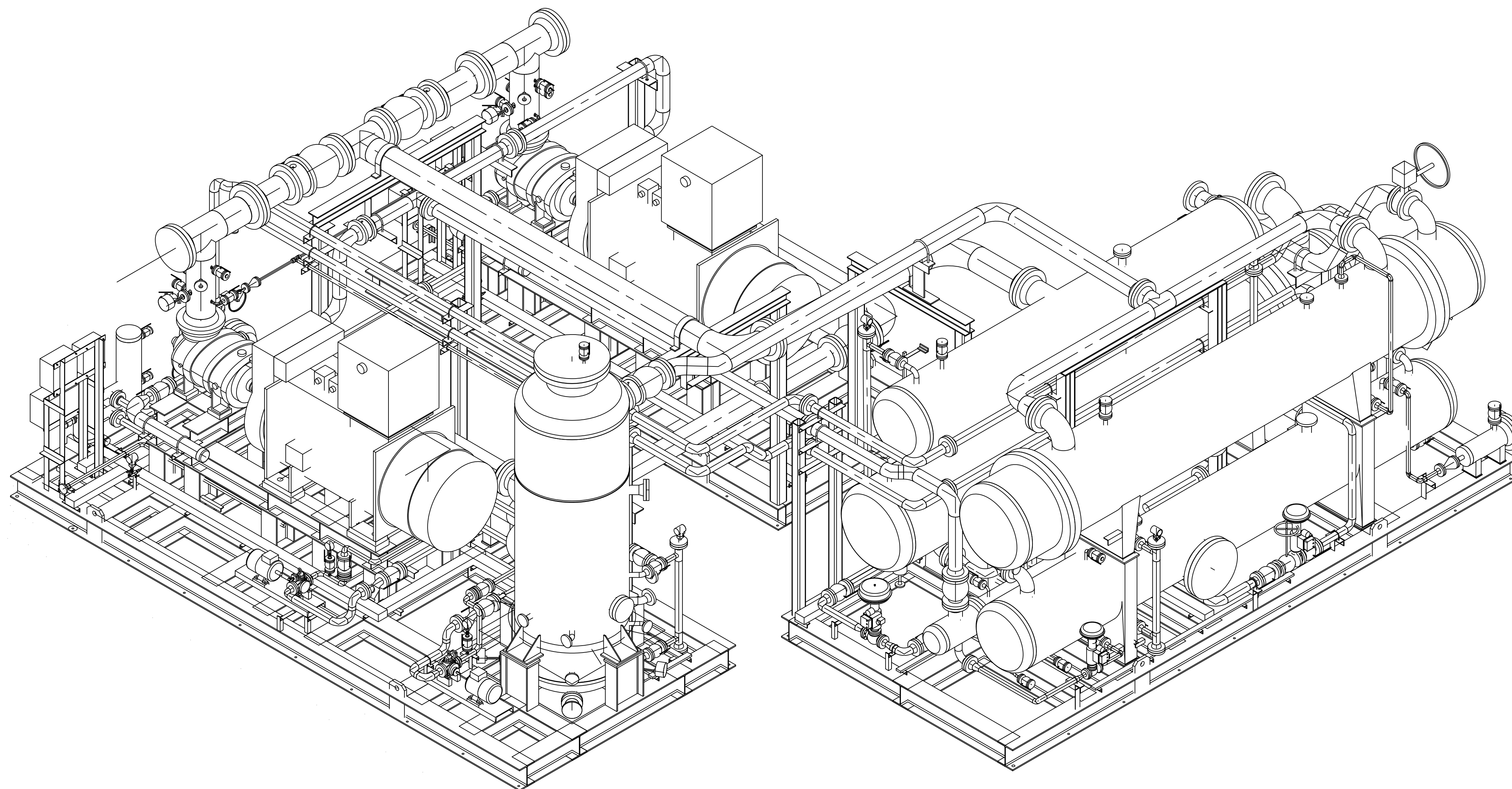

02	09.10.2025	IFR	FA	IM	OG
01	16.09.2025	IFR	FA	IM	OG
00	28.06.2025	IFR	FA	IM	OG
REV.	DATE (dd.MMM.YY)	Purpose of Issue	Prepared	Checked	Approved

		Gachasan Polymer Industries Company HDPE Plant		
PO No.: GPIC-PT-MA-PO-000-3029			SCALE: 3/8":1'	
DRAWING TITLE: General Arrangement Drawing (2D) ("Tie-In Points , Skid Dimensions & Orientation, Including Instrument, Junction Box and Local Panel Location Layout & Instrument Cable routing.) for Refrigerator Package				
DRAWING NO.	VD-GPIC-MA-3029-3029-0062	REV.	SHEET NO.	SIZE
		02	6 OF 9	A1



Code1	<input type="checkbox"/> No Comment/ Approved (Applicable Only for "FOR REVIEW" and "For Approval" Documents) No comment and the document are released for Manufacturing				
Code2	<input type="checkbox"/> No Comment / Approved with Note(s) Vendor/Sub-Contractor shall correct, revise and resubmit the document. The document is released for Manufacturing if changes incorporated.				
Code3	<input type="checkbox"/> Commented Vendor/Sub-Contractor shall correct, revise and resubmit the document by the date specified. The document shall be revised under the Status of "R: Revised Issue". All corrected documents shall be resubmitted before starting the Manufacturing Process				
Code4	<input type="checkbox"/> Not Accepted (Rejected) Vendor/Sub-Contractor shall re-work/re-design/re-specify the contents of the document according to the comments/reasons for rejection. All corrected documents shall be resubmitted before starting the manufacturing. Vendor Sub-Contractor shall not proceed with subsequent works of Material Supply or Manufacturing until receiving Code1/Code2 or No Code from PURCHASER. Vendor/Sub-Contractor shall resubmit the document with the same revision within 6 working days after receiving comments				
No Code	<input type="checkbox"/> No Code (Only for "For Information" Documents and "As Built DWGs") Document has been submitted for PURCHASER'S information (I). Consistency, completeness and correctness of document content is in Vendor/Sub-Contractor's responsibility.				
The above checking result by EIED shall in no way relieve Vendor of any liability, obligation and responsibility out of the purchase order and the mutual agreement in writing					
 DATE : DEPT : Signature :					
CV	PI	EL	IN	ME	MA
ST	BU	PR	SA	HV	TL

02	09.10.2025	IFR	FA	IM	OG
01	16.09.2025	IFR	FA	IM	OG
00	28.06.2025	IFR	FA	IM	OG
REV.	DATE (DD.MM.YY)	Purpose of Issue	Prepared	Checked	Approved

 Gachsaran Polymer Industries Company	 Gachsaran Polymer Industries Company	Gachsaran Polymer Industries Company HDPE Plant	 EIED  DELTA PROCESS EQUIPMENT
---	---	--	--

PO No.: GPIC-PT-MA-PO-000-3029 SCALE: 3/8":1'



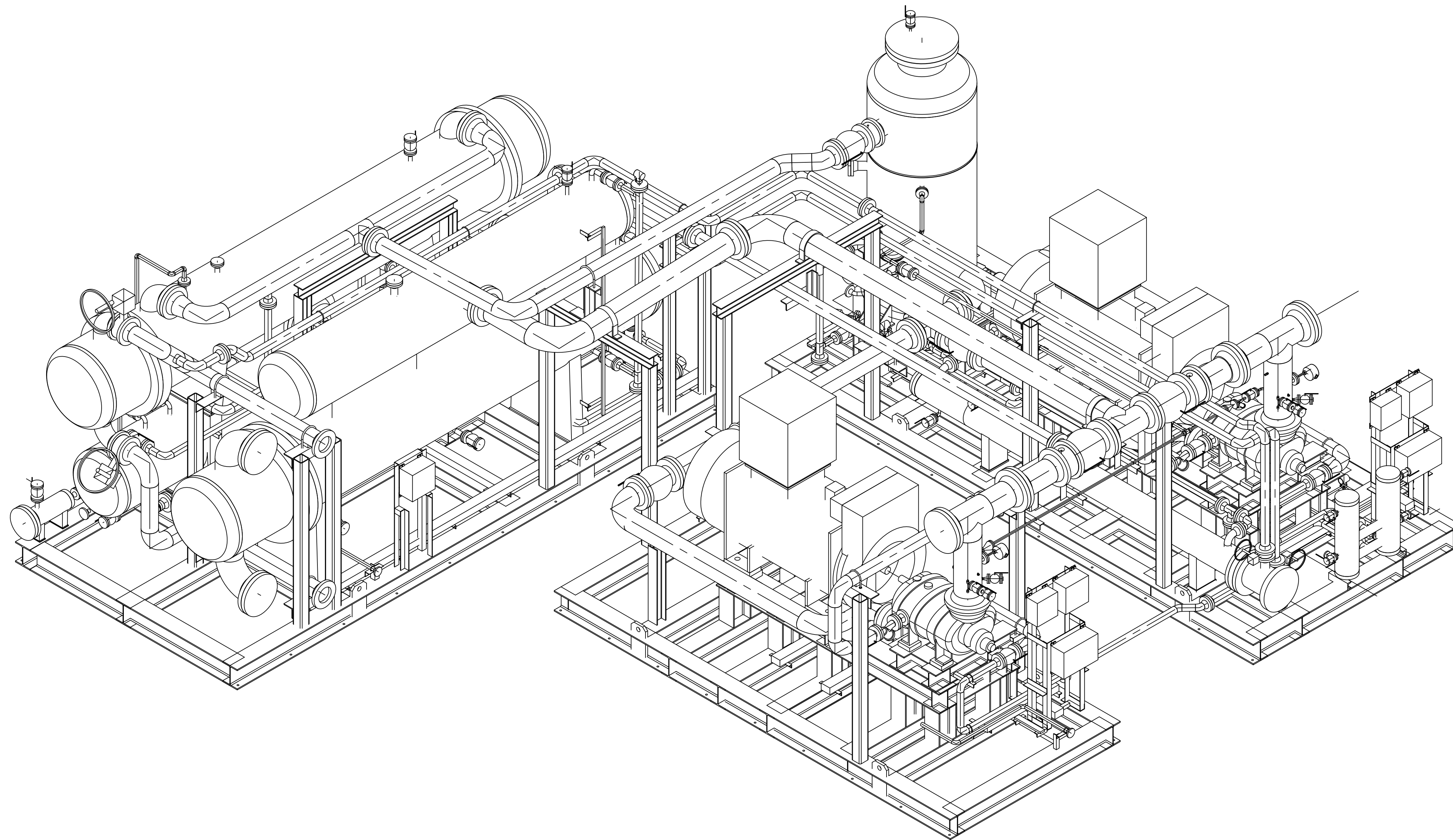

DRAWING TITLE:
 General Arrangement Drawing (2D) ("Tie-In Points, Skid Dimensions & Orientation, Including Instrument, Junction Box and Local Panel Location Layout & Instrument Cable routing.) for Refrigerator Package

DRAWING NO.	REV.	SHEET NO.	SIZE
VD-GPIC-MA-3029-3029-0062	02	7 OF 9	A1



Code1	<input type="checkbox"/> No Comment / Approved (Applicable Only for "FOR REVIEW" and "For Approval" Documents) No comment and the document are released for Manufacturing				
Code2	<input type="checkbox"/> No Comment / Approved with Note(s) Vendor/Sub-Contractor shall correct, revise and resubmit the document. The document is released for Manufacturing if changes incorporated.				
Code3	<input type="checkbox"/> Commented Vendor/Sub-Contractor shall correct, revise and resubmit the document by the date specified. The document shall be revised under the Status of "R: Revised Issue". All corrected documents shall be resubmitted before starting the Manufacturing Process				
Code4	<input type="checkbox"/> Not Accepted (Rejected) Vendor/Sub-Contractor shall re-work/re-design/re-specify the contents of the document according to the comments/reasons for rejection. All corrected documents shall be resubmitted before starting the manufacturing. Vendor Sub-Contractor shall not proceed with subsequent works of Material Supply or Manufacturing until receiving Code1/Code2 or No Code from PURCHASER. Vendor/Sub-Contractor shall resubmit the document with the same revision within 6 working days after receiving comments				
No Code	<input type="checkbox"/> No Code (Only for "For Information" Documents and "As Built DWGs") Document has been submitted for PURCHASER'S information (I). Consistency, completeness and correctness of document content is in Vendor/Sub-Contractor's responsibility.				
The above checking result by EIED shall in no way relieve Vendor of any liability, obligation and responsibility out of the purchase order and the mutual agreement in writing					
 DATE : DEPT: Signature :					
CV	PI	EL	IN	ME	MA
ST	BU	PR	SA	HV	TL

02	09.10.2025	IFR	FA	IM	OG
01	16.09.2025	IFR	FA	IM	OG
00	28.06.2025	IFR	FA	IM	OG
REV.	DATE (DD.MM.YY)	Purpose of Issue	Prepared	Checked	Approved

 Gachsaran Polymer Industries Company		Gachsaran Polymer Industries Company HDPE Plant	 
---	---	--	--

PO No.: GPIC-PT-MA-PO-000-3029 SCALE: 3/8":1'



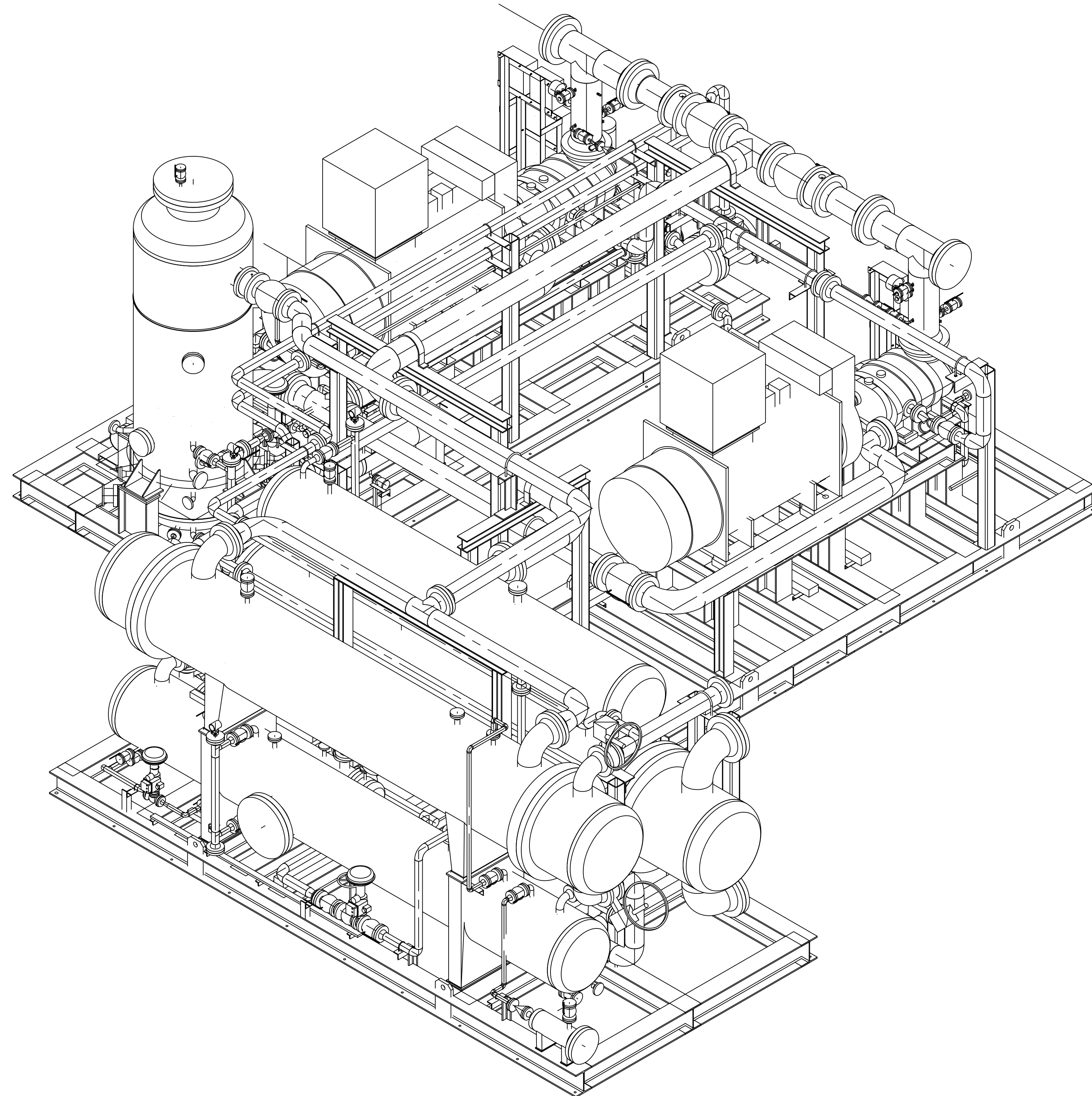

DRAWING TITLE:
 General Arrangement Drawing (2D) (*Tie-In Points, Skid Dimensions & Orientation, Including Instrument, Junction Box and Local Panel Location Layout & Instrument Cable routing.)
 for Refrigerator Package

DRAWING NO.	VD-GPIC-MA-3029-3029-0062	REV.	SHEET NO.	SIZE
		02	8 OF 9	A1



Code1	<input type="checkbox"/> No Comment/ Approved (Applicable Only for "FOR REVIEW" and "For Approval" Documents) No comment and the document are released for Manufacturing				
Code2	<input type="checkbox"/> No Comment / Approved with Note(s) Vendor/Sub-Contractor shall correct, revise and resubmit the document. The document is released for Manufacturing if changes incorporated.				
Code3	<input type="checkbox"/> Commented Vendor/Sub-Contractor shall correct, revise and resubmit the document by the date specified. The document shall be revised under the Status of "R: Revised Issue". All corrected documents shall be resubmitted before starting the Manufacturing Process				
Code4	<input type="checkbox"/> Not Accepted (Rejected) Vendor/Sub-Contractor shall re-work/re-design/re-specify the contents of the document according to the comments/reasons for rejection. All corrected documents shall be resubmitted before starting the manufacturing. Vendor Sub-Contractor shall not proceed with subsequent works of Material Supply or Manufacturing until receiving Code1/Code2 or No Code from PURCHASER. Vendor/Sub-Contractor shall resubmit the document with the same revision within 6 working days after receiving comments				
No Code	<input type="checkbox"/> No Code (Only for "For Information" Documents and "As Built DWGs") Document has been submitted for PURCHASER'S information (I). Consistency, completeness and correctness of document content is in Vendor/Sub-Contractor's responsibility. The above checking result by EIED shall in no way relieve Vendor of any liability, obligation and responsibility out of the purchase order and the mutual agreement in writing				
 DATE : DEPT : Signature :					
CV	PI	EL	IN	ME	MA
ST	BU	PR	SA	HV	TL

02	09.10.2025	IFR	FA	IM	OG
01	16.09.2025	IFR	FA	IM	OG
00	28.06.2025	IFR	FA	IM	OG
REV.	DATE (DD.MM.YY)	Purpose of Issue	Prepared	Checked	Approved

 Gachsaran Polymer Industries Company		Gachsaran Polymer Industries Company HDPE Plant	  DELTA PROCESS EQUIPMENT
---	---	--	--

PO No.: GPIC-PT-MA-PO-000-3029 SCALE: 3/8":1'

DRAWING TITLE:
 General Arrangement Drawing (2D) (Tie-In Points, Skid Dimensions & Orientation, Including Instrument, Junction Box and Local Panel Location Layout & Instrument Cable routing.)
 for Refrigerator Package

DRAWING NO.	VD-GPIC-MA-3029-3029-0062	REV.	SHEET NO.	SIZE
		02	9 OF 9	A1