



**DEHDASHT PETROCHEMICAL INDUSTRY COMPANY**  
**DEHDASHT HIGH DENSITY POLYETHYLENE PROJECT**





Contract No.: DPIC/98-12	DOCUMENT TITLE: NDE Procedure	POI: IFA	Rev.: D0
	DOCUMENT No: DPIC9812-000-VD-1002-ME-PRC-0070	Sheet 1 of 57	

# NDE Procedure



PURCHASER'S COMMENT/APPROVAL STATUS						Purchaser: NARGAN
1	AP: Approved (Released for Manufacturing)					Requisition No.: DPIC98-12-001-000-ME-MR-4150-0001-D1
✓	AN: Approved With Minor Comments (Fabrication may Proceed)					
3	NF: Approved With Comments (Fabrication not Proceed)					
4	RJ: Rejected					Item No. (Tag No.): PK-6101
5	NR: Not be Returned					
Date:	<span style="border: 1px solid red; padding: 2px;">27-11-21</span>	Signature:				Vendor Doc. No.: DPIC9812-000-VD-1002-ME-PRC-0070
D0	22-Nov-21	IFA	E.Nasrollahi	M.Razmgir	S.Kabiriyani	
REV.	DATE ISSUE	Purpose of Issue	PREPARED	CHECKED	APPROVED	



	<b>DEHDASHT PETROCHEMICAL INDUSTRY COMPANY</b>  <b>DEHDASHT HIGH DENSITY POLYETHYLENE PROJECT</b>		
<b>Contract No.: DPIC/98-12</b>	<b>DOCUMENT TITLE: NDE Procedure</b>	<b>POI: IFA</b>	<b>Rev.: D0</b>
	<b>DOCUMENT No: DPIC9812-000-VD-1002-ME-PRC-0070</b>	<b>Sheet 3 of 57</b>	

## TABLE OF CONTENTS

1	Definition .....	4
2	Part 1 : Ultrasonic Examination Procedure .....	5
3	Part 2 : Liquid Penetrant Examination Procedure .....	21
4	Part 3 : Radiographic Examination Procedure (Gamma-Ray Examination) .....	28
5	Part4: Magnetic Particle Examination Procedure .....	37
5	Part5: Appendix.....	44

	<p align="center"><b>DEHDASHT PETROCHEMICAL INDUSTRY COMPANY</b></p> <p align="center"><b>DEHDASHT HIGH DENSITY POLYETHYLENE PROJECT</b></p>		
<p><b>Contract No.: DPIC/98-12</b></p>	<p><b>DOCUMENT TITLE: NDE Procedure</b></p>	<p><b>POI: IFA</b></p>	<p><b>Rev.: D0</b></p>
	<p><b>DOCUMENT No: DPIC9812-000-VD-1002-ME-PRC-0070</b></p>	<p align="center"><b>Sheet 4 of 57</b></p>	



## DEFINITIONS

**Client / Owner** Persian Gulf Petrochemical Industrial Co.  
(PGPIC)

**EPC Contractor** Petropars Iran / Nargan Joint Venture

Vendor: KASRAVAND Co.



Project: DEHDASHT HIGH DENSITY POLYETHYLENE PROJECT

	<p align="center"><b>DEHDASHT PETROCHEMICAL INDUSTRY COMPANY</b></p> <p align="center"><b>DEHDASHT HIGH DENSITY POLYETHYLENE PROJECT</b></p>		
<p><b>Contract No.: DPIC/98-12</b></p>	<p><b>DOCUMENT TITLE: NDE Procedure</b></p>	<p><b>POI: IFA</b></p>	<p><b>Rev.: D0</b></p>
	<p><b>DOCUMENT No: DPIC9812-000-VD-1002-ME-PRC-0070</b></p>	<p align="center"><b>Sheet 5 of 57</b></p>	

Vendor shall explain following NDE procedure is applicable for which equipment of refrigeration package and also whether it is applicable for his own manufacturing equipment.



## Part 1

# Ultrasonic Examination Procedure

	<b>DEHDASHT PETROCHEMICAL INDUSTRY COMPANY</b>  <b>DEHDASHT HIGH DENSITY POLYETHYLENE PROJECT</b>		
<b>Contract No.: DPIC/98-12</b>	<b>DOCUMENT TITLE: NDE Procedure</b>	<b>POI: IFA</b>	<b>Rev.: D0</b>
	<b>DOCUMENT No: DPIC9812-000-VD-1002-ME-PRC-0070</b>	<b>Sheet 6 of 57</b>	

## Table of Content

1	Scope.....	7
2	Reference Documents.....	7
3	General Requirements .....	7
4	Equipment .....	8
5	Calibration Blocks.....	9
6	Surface Condition .....	10
7	Instrument Calibration .....	10
8	Transfer Variation Correction .....	12
9	Scanning Sensitivity.....	12
10	Information Prior To Inspection .....	12
11	Inspection Sequence .....	12
12	Evaluation Of Indications .....	13
13	Acceptance Criteria .....	14
14	Post Examination Cleaning.....	15
15	Reporting.....	15
16	Calibration Blocks Figure.....	17

	<b>DEHDASHT PETROCHEMICAL INDUSTRY COMPANY</b>  <b>DEHDASHT HIGH DENSITY POLYETHYLENE PROJECT</b>		
<b>Contract No.: DPIC/98-12</b>	<b>DOCUMENT TITLE: NDE Procedure</b>	<b>POI: IFA</b>	<b>Rev.: D0</b>
	<b>DOCUMENT No: DPIC9812-000-VD-1002-ME-PRC-0070</b>	<b>Sheet 7 of 57</b>	

## 1. Scope

- 1.1** This procedure describes the minimum requirements for carrying out ultrasonic examination of welds and adjacent base material by manual contact method of carbon steel & Stainless Steel plates, pipes, forgings and cast materials of thickness 5 mm to 150mm for Refrigeration Package .
- 1.2** Where required by the referencing Code Section, this procedure shall be demonstrated to the satisfaction of the Authorized Inspector prior to implementation and demonstration records shall be maintained.
- 1.3** When Procedure qualification is specified, a change of requirement stated in Table T-422 of ASME Section V identified as essential variable from the specified Value, or range of values, shall require re qualification of this procedure. A similar change in the non-essential variables, however, does not require re-qualification of this procedure.
- 1.4** The extent of examination shall depend on the contract and/or applicable code requirements and approved tank and vessel welding book.

## 2. Reference Documents

**2.1** The latest edition of the following documents shall be referred to in conjunction with this procedure:



- a) ASME Sec. V Boiler and Pressure Vessel Code- NDE. Ed. 2019
- b) ASME B31.3 Chemical Plant and Petroleum Refinery Piping.
- c) NDT Personnel Qualification and certification
- e) Job specification for welding and NDE of pressure vessels and heat exchangers DPIC9812-000-000-ME-JSS-6300-0001

**2.2** In case of conflict between this procedure and any project specifications, datasheets, referenced standards and codes, it shall be drawn immediately to attention of Employer (COMPANY) in writing for approval before commencement of work.

## 3. General Requirements

**3.1** Personnel Qualification:

**3.1.1** Only certified NDE ASNT Level II or NDE ASNT Level III personnel shall interpret and evaluate examination results.

	<b>DEHDASHT PETROCHEMICAL INDUSTRY COMPANY</b>  <b>DEHDASHT HIGH DENSITY POLYETHYLENE PROJECT</b>		
<b>Contract No.: DPIC/98-12</b>	<b>DOCUMENT TITLE: NDE Procedure</b>	<b>POI: IFA</b>	<b>Rev.: D0</b>
	<b>DOCUMENT No: DPIC9812-000-VD-1002-ME-PRC-0070</b>	<b>Sheet 8 of 57</b>	



### 3.2 Written Procedure Requirement

#### Procedure Qualification

When procedure qualification is specified, a change of requirement in the below Table identified as an essential variable from the specified value, or range of values, shall require re-qualification of the written procedure. A change of a requirement identified as a nonessential variable from the specified value, or range of values, does not require re-qualification of the written procedure. All changes of essential or Non essential variables from the value, or range of values, specified by the written procedure shall require revision of, or an addendum to, the written procedure.

**VARIABLES OF AN ULTRASONIC EXAMINATION PROCEDURE**

SI. No	REQUIREMENT	ESSENTIAL VARIABLE	NON ESSENTIAL VARIABLE
1	Material types and configuration, weld configurations to be examined, including thickness dimension and product form (casting, forging, plates, etc..)	X	
2	Personnel qualification requirement		X
3	Personnel performance requirement, when required	X	
4	The surface from which the examination shall be performed	X	
5	Surface condition (examination shall be performed)		X
6	Couplant: brand name or type		X
7	Technique(s) (straight beam, angle beam, conduct, and or immersion)	X	
8	Angles and modes of wave propagation in the material	X	
9	Search unit types, frequency and element size shape	X	
10	Special search unit, wedges, shoes, or saddles, when used	X	
11	Ultrasonic instrument	X	
12	Calibration blocks and technique	X	
13	Directions and extent of scanning	X	
14	Automatic alarm and or recording equipment, when applicable		X
15	Scanning(manual Vs automatic)	X	
16	Method for sizing indications	X	
17	Computer enhanced data acquisition, when used	X	
18	Records, including minimum calibration data to be recorded(e.g., instrument settings)		X
19	Scan overlap(decrease only)	X	

	<b>DEHDASHT PETROCHEMICAL INDUSTRY COMPANY</b>  <b>DEHDASHT HIGH DENSITY POLYETHYLENE PROJECT</b>		
<b>Contract No.: DPIC/98-12</b>	<b>DOCUMENT TITLE: NDE Procedure</b>	<b>POI: IFA</b>	<b>Rev.: D0</b>
	<b>DOCUMENT No: DPIC9812-000-VD-1002-ME-PRC-0070</b>	<b>Sheet 9 of 57</b>	

## 4. Equipment

**4.1** Ultrasonic flaw detector shall be of pulse-echo type with an A-scan display. The instrument shall be capable of operating at frequencies over the range of at least 1 to 5 MHz and shall be equipped with a stepped gain control in units of 2.0 dB or less, e.g. Krautkramer USM 35 DAC etc.

**4.2** Transducers can be either single or dual crystal elements. The nominal frequency shall be between 1 to 5 MHz.

**4.3** For straight beam examination, longitudinal wave transducers shall have crosssection size of diameter 10 to 25mm.

**4.4** For angle beam examination, shear wave transducers having cross-section size of 8 mm x 9 mm to dia.10 mm x15 mm shall be used. The crystal dimensions shall be selected appropriate to contact examination surface. Nominal transducer angle shall be 45°, 60° and 70° and the angle of the transducer shall be selected according to the material thickness, its acoustic property, included angle and type of the weld bevel.



**4.5** Co-axial cables of a length of 6 ft. to 15 ft. with suitable connectors, mimic gauge (wire type for final weld profile) and soldering wire (for heel/throat profiles of TKY joints) shall be available to the UT operator.

**4.6** Search units with contoured contact wedges may be used to aid ultrasonic coupling. Calibration shall be done with the contact wedges to be used during the examination.

**4.7** The couplant, including additives, shall not be detrimental to the material being examined. Cellulose paste, glycerin, oil, grease or other proprietary brand couplant may be used. Same couplant shall be used on calibration blocks as on the item to be tested.

**4.8** When used on or when it may come in contact with nickel base alloys, the couplant shall not contain more than 250 ppm of sulfur. Similarly, for austenitic stainless steel or titanium, the couplant shall not contain more than 250ppm of halides (chlorides plus fluorides)

**4.9** The amplitude linearity of the ultrasonic instrument shall be accurate over its useful range to + 20% of the nominal amplitude ratio, to allow measurement of indications beyond the linear range of the vertical display on the screen. Refer Appendix I of this procedure for the method to check amplitude linearity. **4.10** Screen height linearity shall be within +5% of the full screen height for 20% to 80% of the calibrated screen points. Refer Appendix I for the procedure, which shall be performed at the beginning of each period of extended use or 3 months, whichever is less.

	<p align="center"><b>DEHDASHT PETROCHEMICAL INDUSTRY COMPANY</b></p> <p align="center"><b>DEHDASHT HIGH DENSITY POLYETHYLENE PROJECT</b></p>		
<p><b>Contract No.: DPIC/98-12</b></p>	<p><b>DOCUMENT TITLE: NDE Procedure</b></p>	<p><b>POI: IFA</b></p>	<p><b>Rev.: D0</b></p>
	<p><b>DOCUMENT No: DPIC9812-000-VD-1002-ME-PRC-0070</b></p>	<p align="center"><b>Sheet 10 of 57</b></p>	

## 5. Calibration Blocks

**5.1** Calibration and reference blocks shall be provided so as to enable system calibration in accordance with the referencing code. These blocks may include but are not limited to the following:

IIW Calibration block V1.

IIW Calibration block V2.

IOW blocks.

ASME basic calibration blocks – (see fig-5 and table 1 for details)

**5.2** The reference block material shall be of the same product form and material specification or equivalent P-Number grouping as one of the materials being examined. For calibration block of dissimilar metal welds, the material selection shall be based on the side of the weld from which the examination will be conducted. When two or more base material thicknesses are involved, the calibration block

Thickness shall be determined by the average thickness of the weld.

**5.3** For examination of Pipe materials with diameter 20 in. (508 mm) and less, the basic calibration block shall be curved. A single curved basic calibration block may be used to calibrate for the examination of surfaces in the range from 0.9 to 1.5 times the basic calibration block. The calibration reflectors shall be longitudinal and circumferential notches on both the inner and outer surfaces. The sizes, locations of

The calibration reflectors and ratio limits for curved surfaces are shown in figure 1 and 2 respectively.

**5.4** The temperature differential between the calibration block and examination



Surfaces shall be within 25 °F (14°C).

**5.5** Horizontal & vertical linearity shall be qualified as per ASME Sec.V.

## 6. Surface Condition

**6.1** The base material surface shall be free from any weld spatter, surface. Irregularities or substances that could interfere with the examination.

**6.2** The weld surface may be in the as welded condition provided this does not interfere with the examination. Where any weld surface preparation is required, this is to be agreed with the client on a case-by-case basis.

	<p align="center"><b>DEHDASHT PETROCHEMICAL INDUSTRY COMPANY</b></p> <p align="center"><b>DEHDASHT HIGH DENSITY POLYETHYLENE PROJECT</b></p>		
<p><b>Contract No.: DPIC/98-12</b></p>	<p><b>DOCUMENT TITLE: NDE Procedure</b></p>	<p><b>POI: IFA</b></p>	<p><b>Rev.: D0</b></p>
	<p><b>DOCUMENT No: DPIC9812-000-VD-1002-ME-PRC-0070</b></p>	<p align="center"><b>Sheet 11 of 57</b></p>	

## 7. Instrument Calibration

### 7.1 ANGLE BEAM CALIBRATION

**7.1.1** The beam index point shall be determined using the IIW V1 or V2 calibration blocks.

**7.1.2** The search unit shall be placed on the block and the echo signal received from the quadrant shall be brought to the maximum amplitude.

**7.1.3** The beam index point shall then be marked on the search unit, which lies directly above the center of the quadrant (see Figure 3).

**7.1.4** To determine the angle of the beam axis, either V1 or V2 block may be used. Position the search unit as shown in Figure 4 and maximize the signal.

**7.1.5** The angle is indicated by the engraved numbers on the side of the block, directly below the marked beam index point.

**7.1.6** Basic calibration block, (see fig 5) shall be used for calibration. This calibration shall provide the following measurements.

**7.1.6.1** Distance range calibration

**7.1.6.2** Distance amplitude correction

**7.1.6.3** Echo amplitude measurement from the surface notch in the basic calibration block.

**7.1.7** Calibration of range scale shall be in accordance with the material thickness and test requirements

**7.1.8** DAC curves shall be prepared in accordance with Appendix II, of this procedure.

**7.2** Straight Beam Calibration:

**7.2.1** The calibration shall provide the following measurements:

**7.2.1.1** Distance range calibration

**7.2.1.2** Distance amplitude correction.



**7.2.2** The horizontal sweep shall be adjusted for distance calibration to present the equivalent of at least two plate wall thicknesses on the display.

**7.2.3** DAC curves shall be prepared in accordance with Appendix II, where required by the applicable code.

**7.3** Re-Calibration.

**7.3.1** When any part of the examination system is changed, a calibration check shall be made on the basic calibration block to verify that 1/4T, 1/2T and 3/4T points on the sweep and distance amplitude correction values recorded satisfy the requirements of 7.1& 7.2 above.

**7.3.2** A calibration check on at least one of the basic reflectors in the basic calibration block or a check using a simulator shall be made at the end of each examination or series of similar

	<b>DEHDASHT PETROCHEMICAL INDUSTRY COMPANY</b>  <b>DEHDASHT HIGH DENSITY POLYETHYLENE PROJECT</b>		
<b>Contract No.: DPIC/98-12</b>	<b>DOCUMENT TITLE: NDE Procedure</b>	<b>POI: IFA</b>	<b>Rev.: D0</b>
	<b>DOCUMENT No: DPIC9812-000-VD-1002-ME-PRC-0070</b>	<b>Sheet 12 of 57</b>	

examinations, every 4 hour during examination, and when examination personnel (except for automated equipment) are changed. The sweep and distance amplitude correction values recorded shall satisfy the values noted prior to the examination.

**7.3.3** Any simulator checks that are used shall be made on the entire examination system. The entire system does not have to be checked in one operation, however, for its check the search unit shall be connected to the ultrasonic instrument and checked against a calibration reflector. Accuracy of the simulator checks shall be confirmed, using the basic calibration block, at the conclusion of each period of extended use, or every 3 months, whichever is less.

**7.3.4** If any of the following are noted, then the area inspected since the last calibration shall be re-examined.

- A point on the DAC line has moved on the sweep line by more than 10% of the sweep division reading.
- A point on the DAC curve has decreased by more than 20% or 2 dB of its amplitude.

**7.3.5** If a point on the DAC curve has increased by more than 20% or 2dB of its amplitude, all indications recorded since the last valid calibration shall be reevaluated and their values amended on the reports.

## 8. Transfer Variation Correction

**8.1** Difference in attenuation between the reference block and material under test due to material differences or surface condition shall be determined and adjustment in scanning sensitivity shall be made accordingly. See Appendix III for method to determine transfer variation correction.



## 9. Scanning Sensitivity

**9.1** The scanning sensitivity shall be set at a minimum of 6 dB higher than the reference level gain setting plus transfer variation correction.

## 10. Information Prior to Inspection

**10.1** Prior to the Ultrasonic examination of welds, the following information shall be provided to the NDT operator as a minimum:

- a) type of material
- b) Joint configuration
- c) Welding process
- d) Any repairs if carried out previously
- e) Post or pre-weld heat treatment
- f) Inspection code and acceptance criteria

	<b>DEHDASHT PETROCHEMICAL INDUSTRY COMPANY</b>  <b>DEHDASHT HIGH DENSITY POLYETHYLENE PROJECT</b>		
<b>Contract No.: DPIC/98-12</b>	<b>DOCUMENT TITLE: NDE Procedure</b>	<b>POI: IFA</b>	<b>Rev.: D0</b>
	<b>DOCUMENT No: DPIC9812-000-VD-1002-ME-PRC-0070</b>	<b>Sheet 13 of 57</b>	

## 11. Inspection Sequence

**11.1** The base material, either side of the joint, shall be scanned using straight beam search unit to determine the presence of any defects or other features which could interfere with the subsequent examination of the joint. Location and areas of any reflectors noted shall be recorded.

**11.2** The weld metal shall be scanned, where required by the referencing code section or project specification, to the extent possible with the straight beam search unit. The scanning shall be performed at a gain setting of at least two times the primary reference level.

**11.3** To detect reflectors oriented parallel to the weld, the angle beam shall be directed at approximate right angles to the weld axis from two directions, where possible. The search unit shall be manipulated so that the ultrasonic energy passes through the required volumes of weld and adjacent base metal.

**11.4** For detection of reflectors oriented transverse to the weld, the angle beam shall be directed essentially parallel to the weld axis.

The search unit shall be manipulated so that the angle beam passes through the required volumes of weld and adjacent base metal. The search unit shall be rotated 180° and the examination repeated.

**11.5** An overlap of at least 10% shall be maintained throughout the scanning to ensure full coverage of the area being examined with a scanning speed not exceeding six inches per second.

**11.6** Welds that cannot be fully examined from two directions using the angle beam technique (eg. Corner and tee joints) shall also be examined, if possible, with a straight beam technique. These areas of restricted access shall be noted in the examination report.



**11.7** Welds that cannot be examined from at least from one side (edge) using the angle beam technique shall be noted in the examination report. For flange welds, the welds may be examined with a straight beam or low angle longitudinal waves from the flange face provided the examination volume can be covered.

**11.8** When examination of weld metal overlay cladding is required by the referencing Code Section, the following techniques shall be used.

**11.8.1** When examination for lack of bond and clad flaw indications is required, the examination shall be performed from the clad surface with the plane separating the elements of the dual element search unit positioned parallel to the axis of the weld bead.

**11.8.2** When examination to check for lack of bond only is required, the examination may be performed from either the clad or unclad surface and the search unit may be moved either perpendicular or parallel to the weld direction.

**11.9** Refer to Appendix IV of this procedure – “Technique Sheets”, for examination technique details.

	<b>DEHDASHT PETROCHEMICAL INDUSTRY COMPANY</b>  <b>DEHDASHT HIGH DENSITY POLYETHYLENE PROJECT</b>		
<b>Contract No.: DPIC/98-12</b>	<b>DOCUMENT TITLE: NDE Procedure</b>	<b>POI: IFA</b>	<b>Rev.: D0</b>
	<b>DOCUMENT No: DPIC9812-000-VD-1002-ME-PRC-0070</b>	<b>Sheet 14 of 57</b>	

## 12. Evaluation of Indications

**12.1** Certain metallurgical discontinuities and geometric conditions may produce indications that are not relevant. The identity, maximum amplitude, location and extent of reflector causing a geometric indication shall be recorded.

**12.2** The following steps shall be taken to classify an indication as geometric:

**12.2.1** Interpret the area containing the reflector in accordance with the applicable examination procedure.

**12.2.2** Plot and verify the reflector coordinates. Prepare a cross sectional sketch showing the reflector position and surface discontinuities such as root and counter bore.

**12.2.3** Review fabrication or weld preparation drawings. Other ultrasonic techniques or nondestructive examination methods, if required, may be used to determine a reflector's true position, size and orientation.

**12.3** Any imperfection that causes an indication in excess of 20% of DAC shall be investigated to the extent that it can be evaluated in terms of the acceptance standards.

**12.4** Reflectors evaluate as laminar reflectors in base materials which interfere with scanning of examination volumes shall require the angle beam examination technique to be modified such that the maximum feasible volume is examined and shall be included in the examination report.



**12.5** Imperfections shall be evaluated for cross-sectional heights of reflectors utilizing proven sizing methods such as '20-dB drop', 'Maximum amplitude' etc. and length of the imperfections shall be determined using proven methods such as '6-dB drop' method, as described below.

**12.5.1** Height – The indication obtained from the discontinuity shall be maximized by probe manipulation and adjusted to a known value e.g. 80% of full screen height.

The search unit shall be moved towards the discontinuity until the indication height begins to drop towards the base line. The location of the leading edge of the indication in relation to the display horizontal base line shall be noted once the indication is dropped by 20 dB from the previously noted maximum height. Moving the search unit away from the discontinuity until the indication height has dropped by 20 dB of the original value, note the location of the leading edge of the indication in relation to the display horizontal base-line scale. The mathematical difference between the two readings noted will be the height of the discontinuity.

**12.5.2** Length – The indication shall be maximized and set to a known value e.g. 80% of full screen height. The search unit, then, shall be moved towards one end of the discontinuity until the indication drops by 6dB (50% of the maximum indication height noted previously). This location shall be carefully marked using a fine-line method. The steps above shall be repeated for locating the opposite end of the

Discontinuity and location shall be marked carefully. The distance between the two locations marked as above will be considered the length of the discontinuity.

	<b>DEHDASHT PETROCHEMICAL INDUSTRY COMPANY</b>  <b>DEHDASHT HIGH DENSITY POLYETHYLENE PROJECT</b>		
<b>Contract No.: DPIC/98-12</b>	<b>DOCUMENT TITLE: NDE Procedure</b>	<b>POI: IFA</b>	<b>Rev.: D0</b>
	<b>DOCUMENT No: DPIC9812-000-VD-1002-ME-PRC-0070</b>	<b>Sheet 15 of 57</b>	

## 13. Acceptance Criteria

**13.1** Acceptance criteria shall depend up on the applicable Code Section. The acceptance criteria for pressure vessel is ASME SEC VIII-Div.1, APPENDIX 12(**Page: 59**).

## 14. Post Examination Cleaning

**14.1** Post examination cleaning shall be carried out where specifically requested by the client. A suitable method of cleaning as agreed with the client shall be employed.

## 15. Reporting

**15.1** All non-reject able indications shall be recorded as specified by the referencing Code section.

**15.2** Reject able indication shall be recorded. As a minimum, the type of indication (i.e. Crack, Non-fusion, and Slag etc.), Location and extent (i.e. length) shall be recorded.

**15.3** A report shall be generated detailing results of the examination. The report shall contain following information, as a minimum.

**15.3.1** Clients' name.

**15.3.2** Project title/number/Job Number

**15.3.3** Work site

**15.3.4** Item description

**15.3.5** Drawing / Weld map number, as applicable

**15.3.6** Material, dimensions, thickness

**15.3.7** Procedure Reference.

**15.3.8** Surface condition/temperature

**15.3.9** Flaw detector make/type/serial number.

**15.3.10** Calibration block used.

**15.3.11** Couplant details.

**15.3.12** Special equipment, if used.

**15.3.13** Simulation blocks, if used.

**15.3.14** Instrument level gain.

**15.3.15** Examination technique.

**15.3.16** Weld/ Position /Joint number



**15.3.17** Welding Process

**15.3.18** Result (accept or reject, details and sketch/map of indications, as and where applicable)




**15.3.19** Examination date and time.



**15.3.20** Technicians name and qualification.

**15.4** A Standard report format is attached in page 17 of this procedure

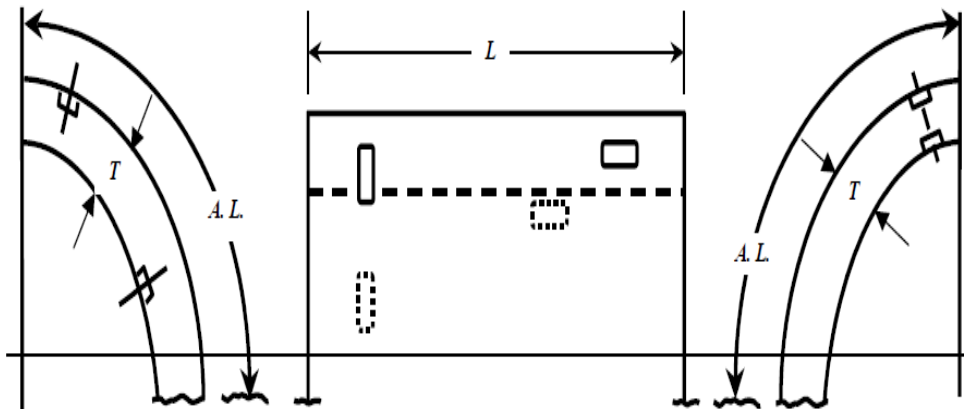
	<b>DEHDASHT PETROCHEMICAL INDUSTRY COMPANY</b>  <b>DEHDASHT HIGH DENSITY POLYETHYLENE PROJECT</b>	
<b>Contract No.: DPIC/98-12</b>	<b>DOCUMENT TITLE: NDE Procedure</b>  <b>DOCUMENT No: DPIC9812-000-VD-1002-ME-PRC-0070</b>	<b>POI: IFA</b> <b>Rev.: D0</b>  <b>Sheet 16 of 57</b>

## 15.5. Sample Inspection Report

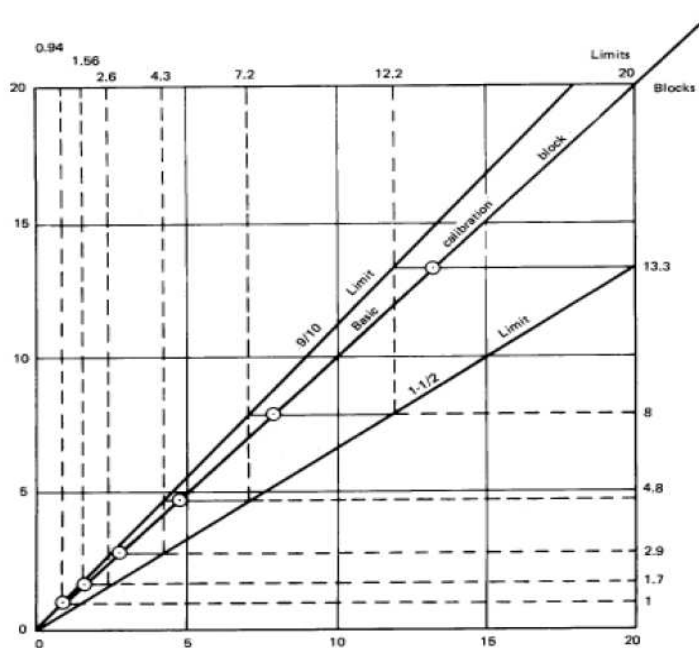
		<b>PROJECT :</b>  <b>DEHDASHT HIGH DENSITY POLYETHYLENE PROJECT</b>  Document Title: Ultrasonic Test Report											
<b>Date:</b>		<b>Document No.:</b>				<b>Page: 1 OF 1</b>							
<b>Equipment :</b>		<b>Drawing No:</b>				<b>Reference :</b>		<b>NDT Procedure</b>					
<b>Equipment No :</b>		<b>Test Characteristic</b>											
<b>Weld Condition :</b> Groove Type : Butt Weld Surface Condition : Smooth/Rough Couplant : Soap		<b>Probe Data :</b> Probe No : A 7258 A (Deg) :70 F (MHz) :2 D (mm) :10				<b>Calibration Data :</b> Calibration Block :DAC BLOCK DAC or DGS Ref: DAC Reference Level (db) :74							
<b>Sketch :</b> 													
<b>Test Result</b>													
Item	Weld Line No	Length Of Test	WPS No	THK	MAT	X (mm)	Y (mm)	T (mm)	Length (mm)	Defect Type	Result		Remark
1											Acc	Rep	100%
2													
3													
4													
5													
6													
7													
8													
9													
10													
11													
<b>NDT Inspector</b>		<b>QC Department Of Kasravand</b>			<b>TPI Inspector</b>			<b>Owner Inspector</b>					
Name :		Name :			Name :			Name :					
Signature :		Signature :			Signature :			Signature :					
Date:		Date:			Date:			Date:					

	<b>DEHDASHT PETROCHEMICAL INDUSTRY COMPANY</b>  <b>DEHDASHT HIGH DENSITY POLYETHYLENE PROJECT</b>	 شرکت صنایع پتروشیمی خلیج فارس Persian Gulf Petrochemical Industries Co <b>PGPIC</b> شرکت صنایع پتروشیمی ادرشت (سهامی عام)	
<b>Contract No.: DPIC/98-12</b>	<b>DOCUMENT TITLE: NDE Procedure</b>	<b>POI: IFA</b>	<b>Rev.: D0</b>
	<b>DOCUMENT No: DPIC9812-000-VD-1002-ME-PRC-0070</b>	<b>Sheet 17 of 57</b>	

## 16. Calibration Blocks Figure



**Figure 1 – ASME Calibration Block - Pipe Welds**



**General Notes:**

- Plot examination surface of basic calibration block on diagonal (45°) line.
- Draw horizontal line through that point from the 3/10 to the 1-1/2 limit line.
- The ends of this line read on the horizontal scale give the range of examination surface diameters, which may be examined with a system calibrated on this block.
- Thickness range requirements shall also be satisfied.

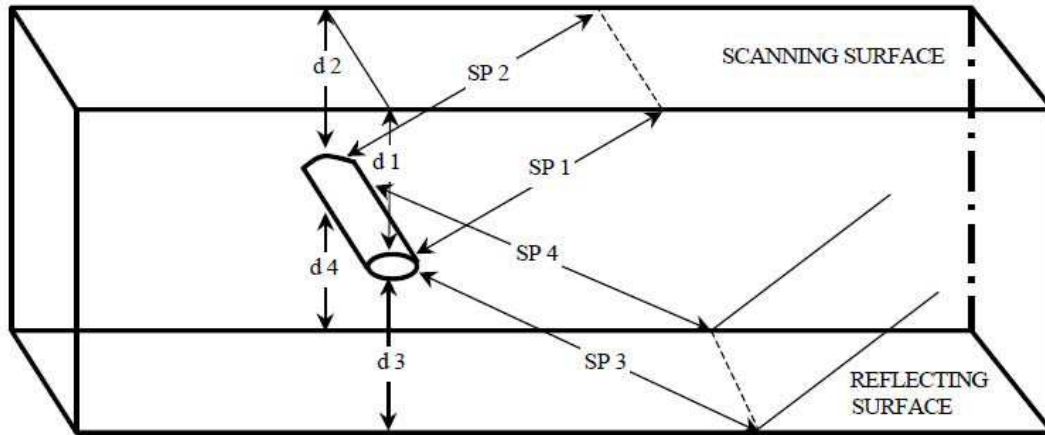
**Figure 2 – Ratio Limits for Curved Surfaces**



DEHDASHT PETROCHEMICAL INDUSTRY COMPANY  
 DEHDASHT HIGH DENSITY POLYETHYLENE PROJECT

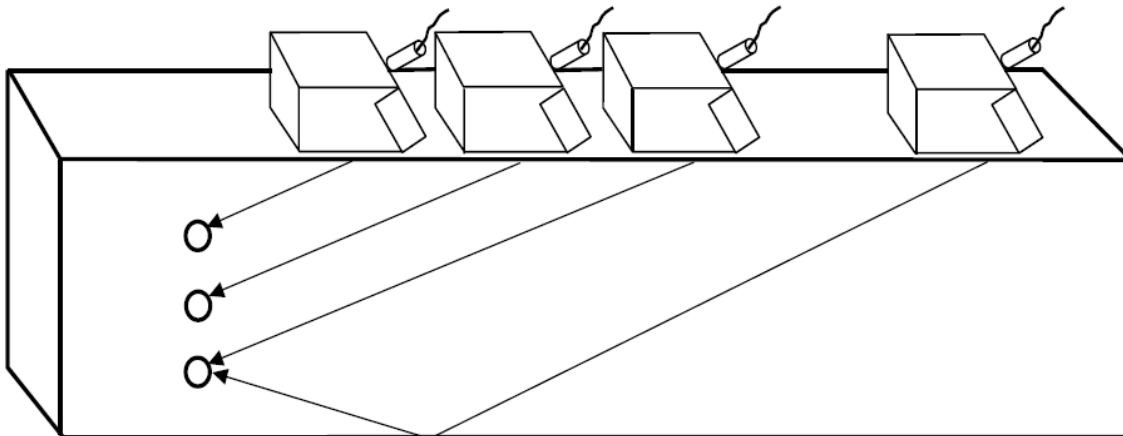


Contract No.: DPIC/98-12	DOCUMENT TITLE: NDE Procedure	POI: IFA	Rev.: D0
	DOCUMENT No: DPIC9812-000-VD-1002-ME-PRC-0070	Sheet 18 of 57	





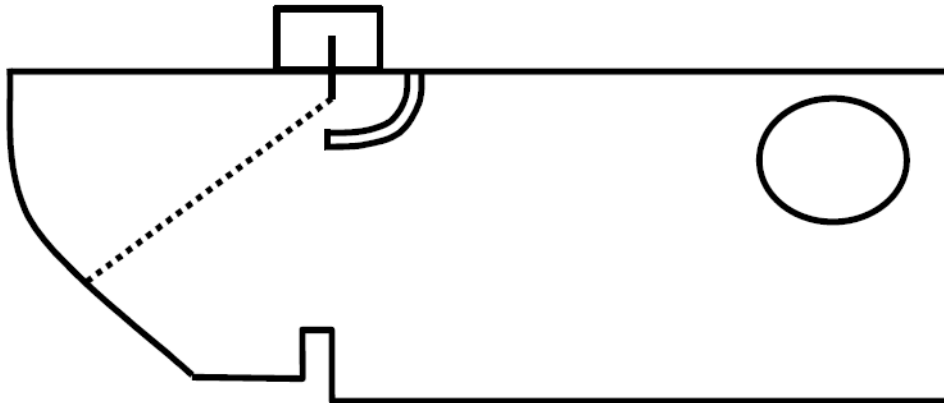
Note:  $d1 = d2 \pm 0.5 \text{ mm}$      $d3 = d4 \pm 0.5 \text{ mm}$   
 $SP1 = SP2 \pm 1 \text{ mm}$      $SP3 = SP4 \pm 1 \text{ mm}$

**Figure 3 – Standard Reference Reflector – AWS D1.1 – ANNEX K**

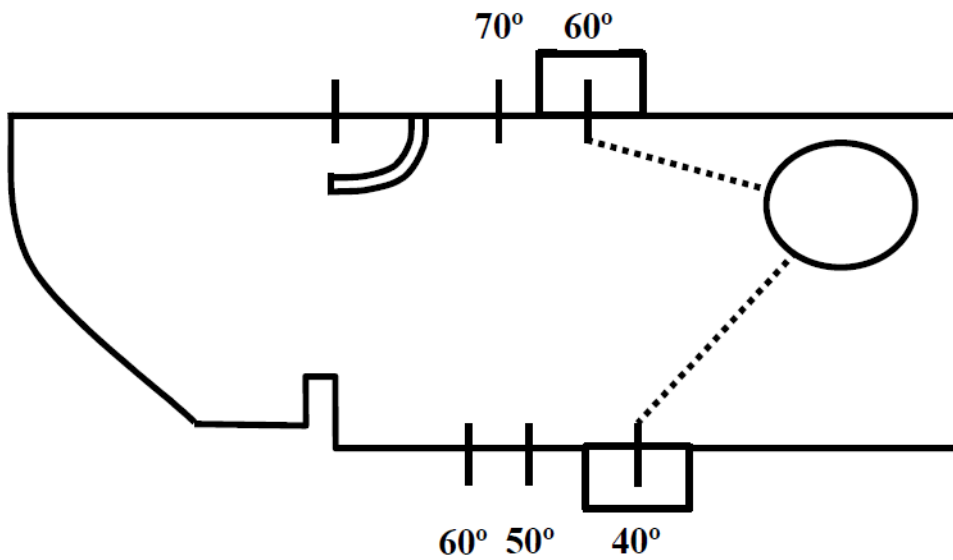


**Figure 4 – Recommended Calibration Block – AWS D1.1, ANNEX K**

	<p style="text-align: center;"><b>DEHDASHT PETROCHEMICAL INDUSTRY COMPANY</b></p> <p style="text-align: center;"><b>DEHDASHT HIGH DENSITY POLYETHYLENE PROJECT</b></p>		
<p>Contract No.: DPIC/98-12</p>	<p>DOCUMENT TITLE: NDE Procedure</p>	<p>POI: IFA</p>	<p>Rev.: D0</p>
<p>DOCUMENT No: DPIC9812-000-VD-1002-ME-PRC-0070</p>		<p style="text-align: center;">Sheet 19 of 57</p>	



**Figure 5 - Determination of Index Point**



**Figure 6 - Determination Of Probe Angle**

Contract No.: DPIC/98-12

DOCUMENT TITLE: NDE Procedure

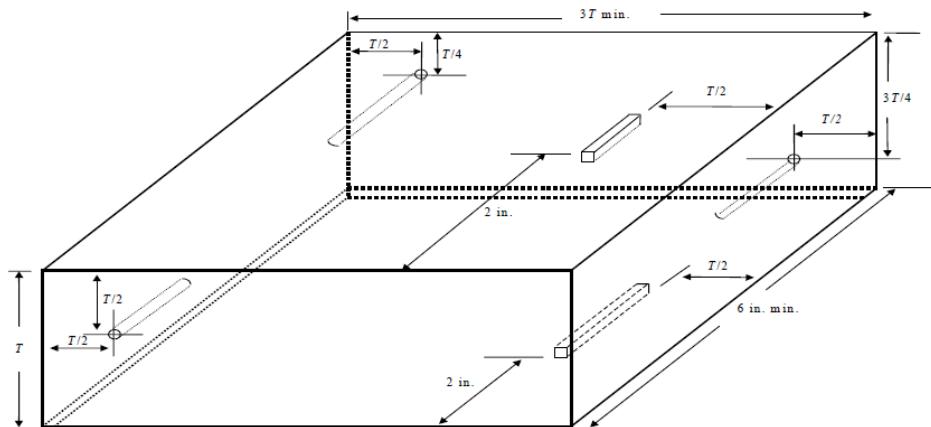
POI: IFA

Rev.: D0

DOCUMENT No: DPIC9812-000-VD-1002-ME-PRC-0070

Sheet 20 of 57

**Figure 7**  
**BASIC CALIBRATION BLOCK - ASME**





**TABLE 1**

Weld Thickness ( <i>t</i> )	Block Thickness ( <i>T</i> )	Hole Diameter
1 in. or less	3/4 in. or <i>t</i>	3/32 in. (2.3 mm - nom)
Over 1 in. through 2 in.	1- 1/2 in. or <i>t</i>	1/8 in. (3.1 mm - nom)
Over 2 in. through 4 in.	3 in. or <i>t</i>	3/16 in. (4.7 mm - nom)
Over 4 in. through 6 in.	5 in. or <i>t</i>	1/4 in. (6.3 mm - nom)
Over 6 in. through 8 in.	7 in. or <i>t</i>	5/16 in. (8 mm - nom)
Over 8 in. through 10 in.	9 in. or <i>t</i>	3/8 in. (9.5 mm - nom)
Over 10 in.	$t \pm 1$ in.	see note 1

**Notch Size:**



- WIDTH** - 1/8 in. to 1/4 in.  
**DEPTH** - 2% *T* or 0.04 in., whichever is greater, into the base metal.  
**LENGTH** - 2 in. min.

**Note 1:** For each increase in weld thickness of 2 in. or fraction thereof over 10 in., the hole diameter shall increase by 1/16 in.

	<p align="center"><b>DEHDASHT PETROCHEMICAL INDUSTRY COMPANY</b></p> <p align="center"><b>DEHDASHT HIGH DENSITY POLYETHYLENE PROJECT</b></p>		
<p><b>Contract No.: DPIC/98-12</b></p>	<p><b>DOCUMENT TITLE: NDE Procedure</b></p>	<p><b>POI: IFA</b></p>	<p><b>Rev.: D0</b></p>
	<p><b>DOCUMENT No: DPIC9812-000-VD-1002-ME-PRC-0070</b></p>	<p align="center"><b>Sheet 21 of 57</b></p>	



## Part 2

# Liquid Penetrant Examination Procedure

	<b>DEHDASHT PETROCHEMICAL INDUSTRY COMPANY</b>  <b>DEHDASHT HIGH DENSITY POLYETHYLENE PROJECT</b>		
<b>Contract No.: DPIC/98-12</b>	<b>DOCUMENT TITLE: NDE Procedure</b>	<b>POI: IFA</b>	<b>Rev.: D0</b>
	<b>DOCUMENT No: DPIC9812-000-VD-1002-ME-PRC-0070</b>	<b>Sheet 22 of 57</b>	

## Table of Content

1	Scope .....	24
2	Reference Documents.....	24
3	Technique.....	25
4	Surface Preparation.....	25
5	Drying After Preparation.....	25
6	Testing Media .....	25
7	Examination .....	26
8	Acceptance Criteria .....	26
9	Post-Test Cleaning.....	27
10	Reporting.....	27

	<b>DEHDASHT PETROCHEMICAL INDUSTRY COMPANY</b>  <b>DEHDASHT HIGH DENSITY POLYETHYLENE PROJECT</b>		
<b>Contract No.: DPIC/98-12</b>	<b>DOCUMENT TITLE: NDE Procedure</b>	<b>POI: IFA</b>	<b>Rev.: D0</b>
	<b>DOCUMENT No: DPIC9812-000-VD-1002-ME-PRC-0070</b>	<b>Sheet 23 of 57</b>	

## 1. Scope

The test procedure is written in accordance with ASME Sec V Article 6, Liquid penetration Examination for pressure vessels fabricated under ASME Section VIII Div. (1) Refrigeration Package.

Table T-621 ASME Sec V



<b>Table T-621.1 Requirements of a Liquid Penetrant Examination Procedure</b>			
Requirement	Essential Variable	Nonessential Variable	
Identification of and any change in type or family group of penetrant materials including developers, emulsifiers, etc.	X	...	
Surface preparation (finishing and cleaning, including type of cleaning solvent)	X	...	
Method of applying penetrant	X	...	
Method of removing excess surface penetrant	X	...	
Hydrophilic or lipophilic emulsifier concentration and dwell time in dip tanks and agitation time for hydrophilic emulsifiers	X	...	
Hydrophilic emulsifier concentration in spray applications	X	...	
Method of applying developer	X	...	
Minimum and maximum time periods between steps and drying aids	X	...	
Decrease in penetrant dwell time	X	...	
Increase in developer dwell time (Interpretation Time)	X	...	
Minimum light intensity	X	...	
Surface temperature outside 40°F to 125°F (5°C to 52°C) or as previously qualified	X	...	
Performance demonstration, when required	X	...	
Personnel qualification requirements	...	X	
Materials, shapes, or sizes to be examined and the extent of examination	...	X	
Post-examination cleaning technique	...	X	

## 2. Reference Documents

**2.1** The latest edition of the following documents shall be referred to in conjunction with this procedure:

- a) ASME Sec. V Boiler and Pressure Vessel Code- ~~NDE~~ Ed. 2019
- d) ASNT-SNT-TC-1A. Procedure for NDT Personnel Qualification and certification
- c) ASME SEC VIII Div. 1 Boiler and Pressure Vessel Code.
- d) Job specification for welding and NDE of pressure vessels and heat exchangers DPIC9812-000-000-ME-JSS-6300-0001

**2.2** In case of conflict between this procedure and any project specifications, datasheets, referenced standards and codes, it shall be drawn immediately to attention of Employer (COMPANY) in writing for approval before commencement of work.

	<b>DEHDASHT PETROCHEMICAL INDUSTRY COMPANY</b>  <b>DEHDASHT HIGH DENSITY POLYETHYLENE PROJECT</b>		
<b>Contract No.: DPIC/98-12</b>	<b>DOCUMENT TITLE: NDE Procedure</b>	<b>POI: IFA</b>	<b>Rev.: D0</b>
	<b>DOCUMENT No: DPIC9812-000-VD-1002-ME-PRC-0070</b>	<b>Sheet 24 of 57</b>	

### 3. Technique

Either a color contrast penetration or fluorescent penetrant technique may be used. In both the cases the penetrant shall be removable by solvent.

### 4. Surface Preparation

In general, satisfactory results may be expected when the surface of the part is in the as welded, as rolled, as cast, or as forged condition. Surface preparation by grinding, machining, or other method may be necessary where the surface irregularities could mask the indications of unacceptable discontinuities.

Prior to any liquid penetration examination, the surface to be examined and all adjacent areas within at list 1 in. shall be dry and free of all dirt, grease, lint, scale, welding flux, weld spatter, oil, and other extraneous matter that matter that could obscure surface opening or otherwise interface with the examination. Cleaning agents that are to be used shall either be detergents or organic solvents.

### 5. Drying After Preparation

After cleaning, the drying of the surfaces to be examined shall be accomplished by normal evaporation or with force hot air as appropriate. A minimal period of 15-min laps shall be permitted to ensure that the cleaning solution has evaporated prior to application of the penetrant.

### 6. Testing Media



**6.1** A solvent-removable system consisting of the following (aerosol spray type) will be used for examination.

Srem Cleaner S-190

Srem Penetrant P-125

Srem Developer A-175

**6.2** The contaminant content for all liquid penetrant materials used on Austenitic stainless steels be according to T-640 of ASME. V and MANDATORY APPENDIX II of ARTICLE 6 of ASME sec V.

	<b>DEHDASHT PETROCHEMICAL INDUSTRY COMPANY</b>  <b>DEHDASHT HIGH DENSITY POLYETHYLENE PROJECT</b>		
<b>Contract No.: DPIC/98-12</b>	<b>DOCUMENT TITLE: NDE Procedure</b>	<b>POI: IFA</b>	<b>Rev.: D0</b>
	<b>DOCUMENT No: DPIC9812-000-VD-1002-ME-PRC-0070</b>	<b>Sheet 25 of 57</b>	

## 7. Examination

### 7.1 Technique for Standard Temperature

As a standard practice, neither the temperature of the penetrant nor the surface of the part to be examined shall be below 15.5°C(60°F) or above 51.6°C(125°F) throughout the examination period. Local heating or cooling is permitted, provided the part temperature remain in the range of 15.5°C to 51.6°C during the examination. Where it is not practical to comply with these temperature limitations, the test may be carried out at another temperature, provided the procedure adopted is qualified as specified in T-653 (Technique for non standard temperatures). Minimum black light intensity shall be 1000  $\mu\text{w}/\text{cm}^2$  and a maximum intensity of 1,100  $\mu\text{W}/\text{cm}^2$ .

### 7.2 Penetrant Application

The penetrant is applied by spraying to the entire surface to be examined. The excess penetrant is allowed to drain from the part after application, while allowing for proper dwell time. In general, a dwell time of 5 to 10-min is sufficient for most of the applications.

### 7.3 Excess Penetrant Removal

After a dwelling time of 5 to 10 min, excess penetrant can be wiped off by a clean lint-free cloth, repeating the operation until most traces of penetrant have been removed. The remaining traces shall be removed by wiping the surface with cloth or absorbent paper moistened with solvent. The direct spraying of the solvent onto the surface following the application of penetrant prior to developing is prohibited.

### 7.4 Drying After Excess Penetrant Removal



For the solvent removal method, the surface may be dried by normal evaporation.

### 7.5 Developing

The developer shall be applied as soon as possible after the removal of penetrant. The time interval shall not exceed 5 min under any circumstances. A nonaqueous developer shall be used with either color contrast or fluorescent penetration.

## 8. Acceptance Criteria

The acceptance criteria of the component shall be evaluated in terms of acceptance standards of ASME Section VIII Div. 1 requirements Appendix 8 (Page:57).



	<p align="center"><b>DEHDASHT PETROCHEMICAL INDUSTRY COMPANY</b></p> <p align="center"><b>DEHDASHT HIGH DENSITY POLYETHYLENE PROJECT</b></p>		
<p><b>Contract No.: DPIC/98-12</b></p>	<p><b>DOCUMENT TITLE: NDE Procedure</b></p>	<p><b>POI: IFA</b></p>	<p><b>Rev.: D0</b></p>
	<p><b>DOCUMENT No: DPIC9812-000-VD-1002-ME-PRC-0070</b></p>	<p align="center"><b>Sheet 26 of 57</b></p>	





## 8. Post-Test Cleaning



Post cleaning is necessary in cases where residual penetrant or developer could interfere with subsequent processing or with service requirements. A simple water rinse, machine wash, or a solvent soap may be employed for the purpose.

## 9. Reporting

A report format has been attached to this procedure and it shall be prepared by PT level II and approved by level II or level III and sent to the concerned, QC inspector.

	<b>DEHDASHT PETROCHEMICAL INDUSTRY COMPANY</b> <b>DEHDASHT HIGH DENSITY POLYETHYLENE PROJECT</b>		
	<b>Contract No.: DPIC/98-12</b>	<b>DOCUMENT TITLE: NDE Procedure</b> <b>DOCUMENT No: DPIC9812-000-VD-1002-ME-PRC-0070</b>	



 		<b>PROJECT :</b> <b>DEHDASHT HIGH DENSITY POLYETHYLENE PROJECT</b>				 		
		<b>Document Title: Liquid Penetrant Test Report</b>						
<b>Date:</b>		<b>Document No.:</b>				<b>Page: 1 OF 1</b>		
<b>Equipment :</b>		<b>Drawing No:</b>						
<b>Equipment No :</b>		<b>Reference :</b>		NDT Procedure				
<b>Test Characteristic</b>								
<b>Technic :</b> <input type="checkbox"/> Fluorescent <input checked="" type="checkbox"/> Visible		<b>Penetrant Type :</b> <input type="checkbox"/> Water Washable <input checked="" type="checkbox"/> Solvent Removable <input type="checkbox"/> Post Emulsifier			<b>Applying Method :</b> <input type="checkbox"/> Brushing <input checked="" type="checkbox"/> Spraying <input type="checkbox"/> Wipe Off			
<b>Penetrant Dwell Time: 15 Min</b>				<b>Developing Time: 7 Min</b>				
<b>Chemical Trade Name :</b> Cleaner : Magnaflux SKC-S Penetrant : Magnaflux SKL-SP2 Developer : Magnaflux SKD-S2								
<b>Test Result</b>								
Item	Weld Line No	Length Of Test	WPS No	THK	MAT	Result		Remark
						Acc	Rep	
1						✓		
2								
3								
4								
5								
6								
7								
<b>QC Department Of Kasravand</b>			<b>TPI Inspector</b>			<b>Owner Inspector</b>		
Name : Signature : Date:			Name : Signature : Date:			Name : Signature : Date:		

	<p align="center"><b>DEHDASHT PETROCHEMICAL INDUSTRY COMPANY</b></p> <p align="center"><b>DEHDASHT HIGH DENSITY POLYETHYLENE PROJECT</b></p>		
<p><b>Contract No.: DPIC/98-12</b></p>	<p><b>DOCUMENT TITLE: NDE Procedure</b></p>	<p><b>POI: IFA</b></p>	<p><b>Rev.: D0</b></p>
	<p><b>DOCUMENT No: DPIC9812-000-VD-1002-ME-PRC-0070</b></p>	<p align="center"><b>Sheet 28 of 57</b></p>	

## Part 3

# Radiographic Examination Procedure



## Gamma-Ray Examination

	<b>DEHDASHT PETROCHEMICAL INDUSTRY COMPANY</b>  <b>DEHDASHT HIGH DENSITY POLYETHYLENE PROJECT</b>		
<b>Contract No.: DPIC/98-12</b>	<b>DOCUMENT TITLE: NDE Procedure</b>	<b>POI: IFA</b>	<b>Rev.: D0</b>
	<b>DOCUMENT No: DPIC9812-000-VD-1002-ME-PRC-0070</b>	<b>Sheet 29 of 57</b>	

## Table of Content

1	Scope .....	31
2	Reference Code .....	31
3	Surface Preparation .....	31
4	Radiography Equipment & Consumable .....	31
5	Developing .....	32
6	Stop Bath Or Rinse .....	32
7	Fixing .....	32
8	Washing .....	32
9	Quality Of Radiographs .....	32
10	Exposure Technique .....	33
11	Intensifying Screens .....	33
12	Penetrometer (IQI) .....	33
13	Placement And Number of IQI .....	33
14	Selection of IQI .....	34
15	Unsharpness Geometric .....	34
16	Density Limitation .....	35
17	Radiography Identification .....	35
18	Back Scattering Check .....	36
19	Storage of Radiograph .....	36
20	Interpretation and Evaluation .....	36
21	Acceptance Standard .....	36
22	Densitometer .....	36
23	Personnel Qualification .....	37
24	Sample Inspection Report .....	38

---

	<p align="center"><b>DEHDASHT PETROCHEMICAL INDUSTRY COMPANY</b></p> <p align="center"><b>DEHDASHT HIGH DENSITY POLYETHYLENE PROJECT</b></p>		
<p><b>Contract No.: DPIC/98-12</b></p>	<p><b>DOCUMENT TITLE: NDE Procedure</b></p>	<p><b>POI: IFA</b></p>	<p><b>Rev.: D0</b></p>
<p><b>DOCUMENT No: DPIC9812-000-VD-1002-ME-PRC-0070</b></p>		<p align="center"><b>Sheet 30 of 57</b></p>	

## 1. Scope

The test procedure is written in accordance with ASME Sec V Article 2, Radiographic test for pressure vessels fabricated under ASME Section VIII Div. (1) for Refrigeration Package.

## 2. Reference Code

ASME Section V Article 2 2018 Edition.

**Ed. 2019**

ASME Section VIII Div. 1 2018 Edition.

SNT – TC – 1A 2006 Edition.

Job specification for welding and NDE of pressure vessels and heat exchangers DPIC9812-000-000-ME-JSS-6300-0001

- In case of conflict between this procedure and any project specifications, datasheets, referenced standards and codes, it shall be drawn immediately to attention of Employer (COMPANY) in writing for approval before commencement of work.

## 3. Surface Preparation

All welded joints before radiography examination shall be subjected to 100% visually inspected. spatter and other surface irregularities that cause difficulty in detecting defects shall be remove.

## 4. Radiography Equipment& Consumable

Films shall be fine grain or ultra-fine grain, high contrast, class 2 or 1 per ASTM E 94.



4.1. Gamma - radiography:

Isotope Type: Ir192 Source size 2 x 3 mm

Film type: ASTM E 1815 – 96 Type 1(e.g. Kodak MX 125 or Agfa D4 or Fuji)

❖ Radiography shall be made using industrial radiography film type class I per ASTM, equivalent to AGFA D4, Kodak, Industrex MX, FUMADUX R4 or FUJI IX50. Width of film should be 10 cm. in special cases; a smaller width film can also be used, provided 15mm of the base metal appear on each side of the weld on the radiograph. Minimum source power should be 20 curie for RT test.

4.2. Processing: Manual Processing shall be used.

	<b>DEHDASHT PETROCHEMICAL INDUSTRY COMPANY</b>  <b>DEHDASHT HIGH DENSITY POLYETHYLENE PROJECT</b>		
<b>Contract No.: DPIC/98-12</b>	<b>DOCUMENT TITLE: NDE Procedure</b>	<b>POI: IFA</b>	<b>Rev.: D0</b>
	<b>DOCUMENT No: DPIC9812-000-VD-1002-ME-PRC-0070</b>	<b>Sheet 31 of 57</b>	

## 5. Developing

Films will be placed in hangers and immersed in developer solution with constant agitation for even development. Developing time shall be in accordance to that recommended by film manufacturer. It shall normally be 5 minutes at 20° C. If developer temperature varies, development time should be adjusted according to manufacturer s recommended time.

## 6. Stop Bath or Rinse

When development is finished, the films shall be immersed in stop bath or rinsed in clean running water to stop the activity of the developer.

## 7. Fixing

Fixing shall be done for at least twice the cleaning time.

## 8. Washing

Washing shall be done with constant flow of clean fresh water. Rate of water flow shall be approximately 5 to 6 times the volume of water tank per hour. Filters should be used if necessary. Minimum time is as per manufacturer’s recommendation.

## 9. Quality of Radiographs



All radiographs shall be free from mechanical, chemical or other blemishes to the extent that they do not mask and are not mask and confused with the image of any discontinuity in the area of interest of the object being radio graphed. Such blemishes include, but are not limited to:

fogging

Processing defects such as streaks, watermarks, or chemical stains.

Scratches, finger marks, crimps, dirt, static marks, or tears.

False indication due to defective screens.

	<b>DEHDASHT PETROCHEMICAL INDUSTRY COMPANY</b>  <b>DEHDASHT HIGH DENSITY POLYETHYLENE PROJECT</b>		
<b>Contract No.: DPIC/98-12</b>	<b>DOCUMENT TITLE: NDE Procedure</b>	<b>POI: IFA</b>	<b>Rev.: D0</b>
	<b>DOCUMENT No: DPIC9812-000-VD-1002-ME-PRC-0070</b>	<b>Sheet 32 of 57</b>	

## 10. Exposure Technique (Appendix I)

Applicable exposure will be chosen based on shape, size and material thickness of the object to be the tested. The technique and time shall be reported on the RT report. Other information is:

Up to 2.5 inch diameter -DWDI (Double Wall Double Image)

Diameter 2.5 to 16 inch – DWSI (Double Wall Single Image)

Above 16 inch – DWSI or SWSI (Double Wall Single Image or Single Wall Single Image)

## 11. Intensifying Screens

The lead screen shall be used with 0.175 mm thickness in front and back of film. Fluorescence screens shall not be used. Location markers shall be used as per Fig. T-275 ASME Sec V.



## 12. Penetrometer (IQI)

IQI shall be wire type and identified in accordance with the thickness of the job to achieve the required sensitivity as per ASME Sec. VIII

## 13. Placement and Number of IQI

The IQI shall be placed transversely across the weld seam at the source side. In cases where placement of IQI on the source side is impracticable , the IQI shall be placed on the film side with an Identification letter “F” at least as high as the identification number either adjacent or on the IQI. One IQI shall be used for each radiograph. Orientation of the IQI shall be such that thickest wire faces the center of its film length. For spherical components where the source is placed at the center of the component for a single exposure, at least three IQI’s, spaced approximately 120 deg. apart, are required under the following conditions:

- (1) When a complete circumference is radiographed using one or more holders, or:
- (2) when a section or section of a circumference, where the length between the ends of outermost section span 24 or more deg. , is radiographed using one or more film holder. Additional film location may require obtaining necessary IQI spacing. When the weld metal is of an alloy group or that has a radiation attenuation that differs from the base material, the IQI material selection shall be based on the weld metal. When the density limits cannot be met with one IQI, and the exceptional density area(s) is at the interface of the weld metal and the base metal, the material selection for the additional IQIs shall be based on the base material.

	<b>DEHDASHT PETROCHEMICAL INDUSTRY COMPANY</b>  <b>DEHDASHT HIGH DENSITY POLYETHYLENE PROJECT</b>		
<b>Contract No.: DPIC/98-12</b>	<b>DOCUMENT TITLE: NDE Procedure</b>	<b>POI: IFA</b>	<b>Rev.: D0</b>
	<b>DOCUMENT No: DPIC9812-000-VD-1002-ME-PRC-0070</b>	<b>Sheet 33 of 57</b>	

## 14. Selection of IQI

- I) IQI's shall be selected from either the same alloy material group or from an alloy material group or grade with less radiation absorb ion than the material being radio graphed according to specification.
- II) For welds with reinforcements, the wire diameter on the IQI is based is the nominal single wall thickness plus the estimated weld reinforcement. Backing rings or strips are not to be considered as part of the thickness in IQI selection. For welds without reinforcement, the thickness on which the IQI is the nominal single wall thickness.

## 15. Unsharpness Geometrics

Geometric unsharpness resulting from the following:

- I) Source size  
 II) Distance from source of radiation to weld or object being radiographed.  
 III) Distance from source to the film Shall be calculated from:

$$U_g = F \cdot d / D$$



Recommended maximum values for geometric unsharpness are as follow

Material Thickness, in (mm)	Us Maximum, in (mm)
Under 2(50)	0.020 (0.51)
2 through . (50-70)	0.030 (0.76)
Over 3 through 4 (75-100)	0.040 (1.02)
Greater than 4 (100)	0.070 (1.78)

**Note:** Material thickness is the thickness on which the IQI is based.

The sfd should be as large as possible to reduce the geometric unsharpness. This relation is dependent on the source strength and the specimen thickness as the time of the exposure will increase in proportion to the square of the distance.

The object to film distance should be kept to the minimum.

	<b>DEHDASHT PETROCHEMICAL INDUSTRY COMPANY</b>  <b>DEHDASHT HIGH DENSITY POLYETHYLENE PROJECT</b>		
<b>Contract No.: DPIC/98-12</b>	<b>DOCUMENT TITLE: NDE Procedure</b>	<b>POI: IFA</b>	<b>Rev.: D0</b>
	<b>DOCUMENT No: DPIC9812-000-VD-1002-ME-PRC-0070</b>	<b>Sheet 34 of 57</b>	



## 16. Density Limitation

Single-film viewing shall be used, and the film density shall be in the range of 2.5 to 3.5. For those instances where the variable thickness makes single film impracticable, with the Client approval, double film viewing may be used. For the double film technique, the film density shall be in the range of 2 to 3.5 for the double film combination or each individual film. Higher densities (up to 4.0) may be acceptable if adequate viewing and satisfactory interpretation of higher density film are permitted by the viewing equipment.

## 17. Radiography Identification

Lead Markers shall be used in radiograph identification. All radiographs must bear the following markings:

- 1) Location markers shall be used for reference of the part being radiographed. These markers are not allowed to be in contact with the weld areas.
- 2) The location or system (for piping) and the joint number shall be clearly marked on the top left hand corner.
- 3) Minimum overlap shall be 25 mm.
- 4) The date shall be shown at the lower right hand corner of the film .the manufacturer shall prepare and document the radiographic technique details .as a minimum, the following information shall be provided:
  - (a) Project Name/Number
  - (b) Manefacturer Abbreviation
  - (c) Identification, e.g. job/contract number and heat number (if applicable)
  - (d) The dimensional map (if used) of marker placement in accordance with T-275 (ASME Sec.V article2).
  - (e)Number of radiographs (exposures)
  - (f)Base material type and thickness, weld thickness, weld reinforcement thickness, as applicable
  - (g) Maximum distance from source side of object to the film
  - (h) Film manufacturer and manufacturer s type /designation
  - (i) Number of film in each film holder /cassette
  - (j) Single or double- wall exposure
  - (k) Single or double-wall viewing
  - (l) Welder Stamp
  - (m) Weld joint No.
  - (n) Repair marks, R1, R2, R3 for repair RS for Reshoot

	<p align="center"><b>DEHDASHT PETROCHEMICAL INDUSTRY COMPANY</b></p> <p align="center"><b>DEHDASHT HIGH DENSITY POLYETHYLENE PROJECT</b></p>		
<p><b>Contract No.: DPIC/98-12</b></p>	<p><b>DOCUMENT TITLE: NDE Procedure</b></p>	<p><b>POI: IFA</b></p>	<p><b>Rev.: D0</b></p>
	<p><b>DOCUMENT No: DPIC9812-000-VD-1002-ME-PRC-0070</b></p>	<p align="center"><b>Sheet 35 of 57</b></p>	

## 18. Back Scattering Check

Back scattering shall be checked with a lead marker "B" minimum 12.7 mm height by 4.2mm thick attached to the back of each film cassette. The film shall be considered unacceptable if a light image appears on the dark background. However, a dark image of the "B" on a lighter background should not be in cause for rejection.

## 19. Storage of Radiograph

Film shall be stored strictly as per manufacturer recommendation.

## 20. Interpretation and Evaluation

All radiographs shall be free from mechanical, chemical, or other blemishes to the extent that they do not mask and are not confused of the object being radiographed. Such blemishes include, but are not limited to:

- (a) Fogging;
- (b) Processing defects such as steaks, watermarks, or chemical stains;
- (c) Scratches, finger marks, crimps, dirtiness, static marks. Smudges, or tears;
- (d) False indications due to defective screens.

## 21. Acceptance Standard

Acceptance Standard for evaluation discontinuities shall be in Accordance with the requirement of UW-51, UW-52 (**Page:60**) and ASME Sec VIII Division 1 Appendix4 (**Page:49**).



## 22. Densitometer

Densitometers shall be calibrated at least every 90 days during use as follows:



A step wedge calibration film, traceable to a national standard step table and having at least 5 step with neutral densities from at least 1.0 through 4.5, shall be used.



## 23. Personnel Qualification

Radiographers shall be qualified to ASNT Level II in accordance with recommended practice in compliance with SNT – TC – 1A (personnel qualification and certification in Nondestructive testing).

	<p align="center"><b>DEHDASHT PETROCHEMICAL INDUSTRY COMPANY</b></p> <p align="center"><b>DEHDASHT HIGH DENSITY POLYETHYLENE PROJECT</b></p>	
<p>Contract No.: DPIC/98-12</p>	<p>DOCUMENT TITLE: NDE Procedure</p> <p>DOCUMENT No: DPIC9812-000-VD-1002-ME-PRC-0070</p>	<p>POI: IFA      Rev.: D0</p> <p align="center">Sheet 36 of 57</p>



## 24. Sample Inspection Report

		<p align="center"><b>PROJECT :</b></p> <p align="center"><b>DEHDASHT HIGH DENSITY POLYETHYLENE PROJECT</b></p>																				
<p>Date:</p>		<p align="center">Document No.:</p>						<p align="center">Page: 1 OF 1</p>														
<p>Equipment :</p>						<p>Drawing No:</p>																
<p>Equipment No :</p>						<p>Reference :</p>		<p>NDT Procedure</p>														
<p align="center"><b>Test Characteristic</b></p>																						
<p>Radiation Source Type :Ir.192 Activity (Ci) :30Ci Source Dimension : 3*3 mm S.F.D : 50 Cm Exposure Time : 8 Min</p>			<p>Film Type : Kodak MX 125 Density : 2.5 Temperature : 23 °C Developing Time : 4 Min</p>			<p>IQI Placement : Film Side IQI Type : EN 6*12 FE U/G : 0.08 Used Technic : SWSI</p>																
<p align="center"><b>Test Result</b></p>																						
Item	Weld Line No	WPS No	THK	MAT	Segment	QTY	Film Size	Defect										Result			Remark	
								Porosity	Slag	Inclusion	Excess Pen	LOF	LOP	R/Concavity	Crack	Burn/Trigim	R/Undercut	Reshoot	Reake	Repair		Accept
1																						
2																						
3																						
4																						
5																						
6																						
7																						
8																						
9																						
10																						
11																						
12																						
13																						
<p align="center"><b>Sub Vendor</b></p>		<p align="center"><b>Kasravand QC Inspector</b></p>			<p align="center"><b>TPI Inspector</b></p>			<p align="center"><b>Owner Inspector</b></p>														
<p>Name :</p>		<p>Name :</p>			<p>Name :</p>			<p>Name :</p>														
<p>Signature :</p>		<p>Signature :</p>			<p>Signature :</p>			<p>Signature :</p>														
<p>Date:</p>		<p>Date:</p>			<p>Date:</p>			<p>Date:</p>														

	<p align="center"><b>DEHDASHT PETROCHEMICAL INDUSTRY COMPANY</b></p> <p align="center"><b>DEHDASHT HIGH DENSITY POLYETHYLENE PROJECT</b></p>		
<p><b>Contract No.: DPIC/98-12</b></p>	<p><b>DOCUMENT TITLE: NDE Procedure</b></p>	<p><b>POI: IFA</b></p>	<p><b>Rev.: D0</b></p>
	<p><b>DOCUMENT No: DPIC9812-000-VD-1002-ME-PRC-0070</b></p>	<p align="center"><b>Sheet 37 of 57</b></p>	



## Part 4

# Magnetic Particle Examination Procedure

	<b>DEHDASHT PETROCHEMICAL INDUSTRY COMPANY</b>  <b>DEHDASHT HIGH DENSITY POLYETHYLENE PROJECT</b>		
<b>Contract No.: DPIC/98-12</b>	<b>DOCUMENT TITLE: NDE Procedure</b>	<b>POI: IFA</b>	<b>Rev.: D0</b>
	<b>DOCUMENT No: DPIC9812-000-VD-1002-ME-PRC-0070</b>	<b>Sheet 38 of 57</b>	

## Table of Content

1	Scope .....	41
2	Application Codes And Standard .....	41
3	Examination Time .....	42
4	Surface Preparation .....	42
5	Examination Medium .....	42
6	Magnetization Method .....	43
7	Calibration of Equipment .....	43
8	Demagnetization .....	43
9	Method Of Examination.....	43
10	Interpretation.....	44
11	Indications Evaluation .....	44
12	Acceptance Criteria .....	44
13	Repairs.....	44
14	Post Cleaning.....	44
15	Personnel Qualification.....	45
16	Sample Inspection Report.....	46

	<b>DEHDASHT PETROCHEMICAL INDUSTRY COMPANY</b>  <b>DEHDASHT HIGH DENSITY POLYETHYLENE PROJECT</b>		
<b>Contract No.: DPIC/98-12</b>	<b>DOCUMENT TITLE: NDE Procedure</b>	<b>POI: IFA</b>	<b>Rev.: D0</b>
	<b>DOCUMENT No: DPIC9812-000-VD-1002-ME-PRC-0070</b>	<b>Sheet 39 of 57</b>	

## 1. Scope

The test procedure is written in accordance with ASME Sec V Article 7, Magnetic Particle Examination for pressure vessels fabricated under ASME Section VIII Div. (1) for Refrigeration Package.

**Table T-721 ASME Sec V**

<b>Table T-721 Requirements of a Magnetic Particle Examination Procedure</b>			
Requirement	Essential Variable	Nonessential Variable	
Magnetizing technique	X	...	
Magnetizing current type or amperage outside range specified by this Article or as previously qualified	X	...	
Surface preparation	X	...	
Magnetic particles (fluorescent/visible, color, particle size, wet/dry)	X	...	
Method of particle application	X	...	
Method of excess particle removal	X	...	
Minimum light intensity	X	...	
Existing coatings, greater than the thickness demonstrated	X	...	
Nonmagnetic surface contrast enhancement, when utilized	X	...	
Performance demonstration, when required	X	...	
Examination part surface temperature outside of the temperature range recommended by the manufacturer of the particles or as previously qualified	X	...	
Shape or size of the examination object	...	X	
Equipment of the same type	...	X	
Temperature (within those specified by manufacturer or as previously qualified)	...	X	
Demagnetizing technique	...	X	
Post-examination cleaning technique	...	X	
Personnel qualification requirements	...	X	

## 2. Application Code and Standards

ASME Sec VIII Appendix 6 ~~2018~~ Edition



Ed. 2019

ASME Sec V. Article 7 ~~2018~~ Edition

SNT-TC-1A 2006 Edition

Job specification for welding and NDE of pressure vessels and heat exchangers DPIC9812-000-000-ME-JSS-6300-0001

- In case of conflict between this procedure and any project specifications, datasheets, referenced standards and codes, it shall be drawn immediately to attention of Employer (COMPANY) in writing for approval before commencement of work.

	<b>DEHDASHT PETROCHEMICAL INDUSTRY COMPANY</b>  <b>DEHDASHT HIGH DENSITY POLYETHYLENE PROJECT</b>		
<b>Contract No.: DPIC/98-12</b>	<b>DOCUMENT TITLE: NDE Procedure</b>	<b>POI: IFA</b>	<b>Rev.: D0</b>
	<b>DOCUMENT No: DPIC9812-000-VD-1002-ME-PRC-0070</b>	<b>Sheet 40 of 57</b>	

### 3. Examination Time

MPI of welds may begin immediately after the completed welds have cooled to ambient temperature.

### 4. Surface Preparation

**4.1.** Prior to magnetic particle Inspection the surface of the part to be examined and all adjacent area within at 50mm shall be clean, dry and free of contaminants such as dirt, oil ,grease,looserust, loose mill sand,loose mill scale, lint, thick paint, welding flux/slag, and weld spatter that might restrict particle movement. When testing a local area, such as weld, the area adjacent to the surface to be examined, must also be cleaned to the extent necessary to permite detection of indications.

**4.2.** If a non-conducting coating is left on the area to be examine that has a thickness greater than 0.05mm, it must be demonstrated that discontinuities can be detected through the maximum thickness applied.

**4.3.** Cleaning of the test surface may be accomplished by detergents, organic solvent, or mechanical means. Welded surface are generally satisfactory, but if the surface is unusually non uniform, interpretation may be difficult because of mechanical entrapment of the magnetic particles. In case of doubt, any questionable area should be re cleaned and reexamined.

### 5. Examination Medium



**5.1.** The magnetic particles used for finding discontinuities will be powder for wet test, fluorescents or non-fluorescents.

**5.2.** The magnetic particles used for magnetic particle inspection should have a very high permeability and a low retentivity. Factors such as the particles density, size, shape and color all affect the sensitivity of the test.

**5.3.** Wet magnetic particles are designed to be suspended in a vehicle such as water or light petroleum distilled in a given concentration for application to the surface by flowing, spraying, or pouring. they are available in both fluorescent and no fluorescent concentrates.

**5.4.** The following medium and /or similar can be used:

- a) Fluxo 7 (white contrast)
- b) Fluxo 3 ( black Ink)

	<p align="center"><b>DEHDASHT PETROCHEMICAL INDUSTRY COMPANY</b></p> <p align="center"><b>DEHDASHT HIGH DENSITY POLYETHYLENE PROJECT</b></p>		
<p><b>Contract No.: DPIC/98-12</b></p>	<p><b>DOCUMENT TITLE: NDE Procedure</b></p>	<p><b>POI: IFA</b></p>	<p><b>Rev.: D0</b></p>
<p><b>DOCUMENT No: DPIC9812-000-VD-1002-ME-PRC-0070</b></p>		<p align="center"><b>Sheet 41 of 57</b></p>	

## 6. Magnetization Method

**6.1.** The method with yoke shall be used.

- a) This method shall be used only to detect some surface discontinuities.
- b) The AC magnetizing technique will be used provided that it has a 4.5 Kg lifting power at the 50 To 100 mm pole spacing.
- c) Two examination at least shall be carried out in every area where the Yoke is placed so that the flux line result approximately perpendicular.
- d) Two examination at least shall be carried out with a sufficient overlapping (Min. 15%) so as to ensure the 100% covering of the surface to be tested.

**6.2.** The following equipment and /or similar can be used:

- a) Western Instrument –WE3HDK

## 7. Calibration of Equipment

The magnetic particle equipment employed should be maintained in proper working order at all times. The frequency of verification calibration, usually every six months, or whenever a malfunction is suspected.

## 8. Demagnetization

When residual magnetism in the part could interfere with subsequent or usage, the part shall be demagnetized any time after completion of the examination.

## 9. Method of Examination



Examination shall be done by continuous method. The wet continuous magnetization technique generally applies to those parts processed on a horizontal wet type unit. It involves bathing the part with the examination medium to provide an abundant source of suspended particles on the surface of the part and terminating the bath application immediately prior to cutting off the magnetizing current. The duration of magnetizing current is typically on the order of (1/2 s) with two or more shots given to the part.

Direction of Magnetization:

At least two separate magnetization direction (approximately perpendicular) shall be performed on each area.

## 10. Interpretation

Non fluorescent particles; For this method the examination is performed using visible light  
A minimum light intensity of 100 foot candles (1000 lux) is required to ensure adequate sensitivity during the examination and evaluation of indications.

	<p align="center"><b>DEHDASHT PETROCHEMICAL INDUSTRY COMPANY</b></p> <p align="center"><b>DEHDASHT HIGH DENSITY POLYETHYLENE PROJECT</b></p>		
<p><b>Contract No.: DPIC/98-12</b></p>	<p><b>DOCUMENT TITLE: NDE Procedure</b></p>	<p><b>POI: IFA</b></p>	<p><b>Rev.: D0</b></p>
<p><b>DOCUMENT No: DPIC9812-000-VD-1002-ME-PRC-0070</b></p>		<p align="center"><b>Sheet 42 of 57</b></p>	

## 11. Indications Evaluation

**11.1** All indications shall be evaluated in terms of the acceptance of the referencing code section.

**11.2** Discontinuities on or near surface indicated by retention of the examination medium.

**11.3** Broad areas of particle accumulation, which might mask indications from discontinuities, are prohibited, and such areas shall be cleaned and re-examined.

**11.4** Any questionable or doubtful indication shall be re-examined to determine whether or not they are relevant.

## 12. Acceptance Criteria

As per ASME Sec VIII Div.1, Appendix 6:

All surfaces to be examined shall be free of:

- (a) relevant linear indications;
- (b) relevant rounded indications greater than 3/16 in. (5 mm)
- (c) four or more relevant rounded indications in a lineseparated by 1/16 in. (1.5 mm) or less, edge to edge.

## 13. Repairs

**13.1** Discontinuities exceeding the above mentioned limits shall be removed, and the part will be repaired according to the applicable procedure.

**13.2** The area under repairing, plus 50mm per each side, shall be checked as per the starting procedure conditions.

## 14. Post Cleaning



Post-test cleaning is necessary where magnetic particle material(s) could interfere with subsequent processing or with service requirements.

The techniques employed are:



- \* Drying of wet particles and subsequent removal by brushing or compressed air.
- \* Removal of wet particles by flushing with solvent.
- \* Other suitable techniques may be used if they will not interfere with subsequent requirements.



## 15. Personnel Qualification

Personnel performing nondestructive testing shall be qualified and certified in accordance with ASNT Qualification Recommended Practice No. SNT-TC-1A. Only individuals qualified for NDT Level I and working under the NDT Level II or individuals qualified for NDT Level II may perform nondestructive testing.

	<p align="center"><b>DEHDASHT PETROCHEMICAL INDUSTRY COMPANY</b></p> <p align="center"><b>DEHDASHT HIGH DENSITY POLYETHYLENE PROJECT</b></p>	
<p><b>Contract No.: DPIC/98-12</b></p>	<p><b>DOCUMENT TITLE: NDE Procedure</b></p> <p><b>DOCUMENT No: DPIC9812-000-VD-1002-ME-PRC-0070</b></p>	<p><b>POI: IFA</b>      <b>Rev.: D0</b></p> <p align="center"><b>Sheet 43 of 57</b></p>



## 16. Sample Inspection Report

	<p><b>PROJECT :</b></p> <p align="center"><b>DEHDASHT HIGH DENSITY POLYETHYLENE PROJECT</b></p> <p align="center"><b>Document Title: Magnetic Particle Test Report</b></p>							
<p><b>Date:</b></p>	<p align="center"><b>Document No.:</b></p>	<p align="right"><b>Page: 1 OF 1</b></p>						
<p><b>Equipment :</b></p>		<p><b>Drawing No:</b></p>						
<p><b>Equipment No :</b></p>		<p><b>Reference :</b></p>	<p>NDT Procedure</p>					
<b>Test Characteristic</b>								
<p><b>Test Time:</b>    <input type="checkbox"/> After Root Pass      <input checked="" type="checkbox"/> After Complete Welding</p>								
<p align="center"><b>Magnetization Equipment :</b></p>		<p align="center"><b>Medium Type :</b></p>						
<p>Brand :</p>		<p>White contrast :</p>						
<p>Model :</p>		<p>Black Ink :</p>						
<p>Current :</p>		<p>Particle type :</p>						
<b>Test Result</b>								
Item	Weld Line No	Length Of Test	WPS No	THK	MAT	Result		Remark
						Acc	Rep	
1								
2								
3								
4								
5								
6								
7								
8								
9								
10								
11								
<p align="center"><b>QC Department Of Kasravand Co.</b></p>		<p align="center"><b>TPI Inspector</b></p>			<p align="center"><b>Owner Inspector</b></p>			
<p>Name :</p>		<p>Name :</p>			<p>Name :</p>			
<p>Signature :</p>		<p>Signature :</p>			<p>Signature :</p>			
<p>Date:</p>		<p>Date:</p>			<p>Date:</p>			

	<p align="center"><b>DEHDASHT PETROCHEMICAL INDUSTRY COMPANY</b></p> <p align="center"><b>DEHDASHT HIGH DENSITY POLYETHYLENE PROJECT</b></p>		
<p><b>Contract No.: DPIC/98-12</b></p>	<p><b>DOCUMENT TITLE: NDE Procedure</b></p>	<p><b>POI: IFA</b></p>	<p><b>Rev.: D0</b></p>
	<p><b>DOCUMENT No: DPIC9812-000-VD-1002-ME-PRC-0070</b></p>	<p align="center"><b>Sheet 44 of 57</b></p>	

# Part 5

## Appendix

	<b>DEHDASHT PETROCHEMICAL INDUSTRY COMPANY</b>  <b>DEHDASHT HIGH DENSITY POLYETHYLENE PROJECT</b>		
<b>Contract No.: DPIC/98-12</b>	<b>DOCUMENT TITLE: NDE Procedure</b>	<b>POI: IFA</b>	<b>Rev.: D0</b>
	<b>DOCUMENT No: DPIC9812-000-VD-1002-ME-PRC-0070</b>	<b>Sheet 45 of 57</b>	

## 1. ASME SEC VIII-Div.1, APPENDIX 4

# MANDATORY APPENDIX 4 ROUNDED INDICATIONS CHARTS ACCEPTANCE STANDARD FOR RADIOGRAPHICALLY DETERMINED ROUNDED INDICATIONS IN WELDS

### 4-1 APPLICABILITY OF THESE STANDARDS

These standards are applicable to ferritic, austenitic, and nonferrous materials.

### 4-2 TERMINOLOGY

(a) *Rounded Indications.* Indications with a maximum length of three times the width or less on the radiograph are defined as rounded indications. These indications may be circular, elliptical, conical, or irregular in shape and may have tails. When evaluating the size of an indication, the tail shall be included. The indication may be from any imperfection in the weld, such as porosity, slag, or tungsten.

(b) *Aligned Indications.* A sequence of four or more rounded indications shall be considered to be aligned when they touch a line parallel to the length of the weld drawn through the center of the two outer rounded indications.

(c) *Thickness t.* *t* is the thickness of the weld, excluding any allowable reinforcement. For a butt weld joining two members having different thicknesses at the weld, *t* is the thinner of these two thicknesses. If a full penetration weld includes a fillet weld, the thickness of the throat of the fillet shall be included in *t*.

### 4-3 ACCEPTANCE CRITERIA

(a) *Image Density.* Density within the image of the indication may vary and is not a criterion for acceptance or rejection.

(b) *Relevant Indications.* (See Table 4-1 for examples.) Only those rounded indications which exceed the following dimensions shall be considered relevant.

- (1)  $\frac{1}{10}t$  for *t* less than  $\frac{1}{8}$  in. (3 mm)
- (2)  $\frac{1}{64}$  in. for *t* from  $\frac{1}{8}$  in. to  $\frac{1}{4}$  in. (3 mm to 6 mm), incl.

(3)  $\frac{1}{32}$  in. for *t* greater than  $\frac{1}{4}$  in. to 2 in. (6 mm to 50 mm), incl.

(4)  $\frac{1}{16}$  in. for *t* greater than 2 in. (50 mm)

(c) *Maximum Size of Rounded Indication.* (See Table 4-1 for examples.) The maximum permissible size of any indication shall be  $\frac{1}{4}t$ , or  $\frac{5}{32}$  in. (4 mm), whichever is smaller; except that an isolated indication separated from an adjacent indication by 1 in. (25 mm) or more may be  $\frac{1}{3}t$ , or  $\frac{1}{4}$  in. (6 mm), whichever is less. For *t* greater than 2 in. (50 mm) the maximum permissible size of an isolated indication shall be increased to  $\frac{3}{8}$  in. (10 mm).

Table 4-1			
Customary Units			
Thickness, <i>t</i> , in.	Maximum Size of Acceptable Rounded Indication, in.		Maximum Size of Nonrelevant Indication, in.
	Random	Isolated	
Less than $\frac{1}{8}$	$\frac{1}{4}t$	$\frac{1}{2}t$	$\frac{1}{10}t$
$\frac{1}{8}$	0.031	0.042	0.015
$\frac{3}{16}$	0.047	0.063	0.015
$\frac{1}{4}$	0.063	0.083	0.015
$\frac{5}{16}$	0.078	0.104	0.031
$\frac{3}{8}$	0.091	0.125	0.031
$\frac{7}{16}$	0.109	0.146	0.031
$\frac{1}{2}$	0.125	0.168	0.031
$\frac{9}{16}$	0.142	0.188	0.031
$\frac{5}{8}$	0.156	0.210	0.031
$\frac{11}{16}$	0.156	0.230	0.031
$\frac{3}{4}$ to 2, incl.	0.156	0.250	0.031
Over 2	0.156	0.375	0.063
SI Units			
Thickness, <i>t</i> , mm	Maximum Size of Acceptable Rounded Indication, mm		Maximum Size of Nonrelevant Indication, mm
	Random	Isolated	
Less than 3	$\frac{1}{4}t$	$\frac{1}{2}t$	$\frac{1}{10}t$
3	0.79	1.07	0.38
5	1.19	1.60	0.38
6	1.60	2.11	0.38
8	1.98	2.64	0.79
10	2.31	3.18	0.79
11	2.77	3.71	0.79
13	3.18	4.27	0.79
14	3.61	4.78	0.79
16	3.96	5.33	0.79
17	3.96	5.84	0.79
19.0 to 50, incl.	3.96	6.35	0.79
Over 50	3.96	9.53	1.60
GENERAL NOTE: This Table contains examples only.			



DEHDASHT PETROCHEMICAL INDUSTRY COMPANY

DEHDASHT HIGH DENSITY POLYETHYLENE PROJECT



Contract No.: DPIC/98-12

DOCUMENT TITLE: NDE Procedure

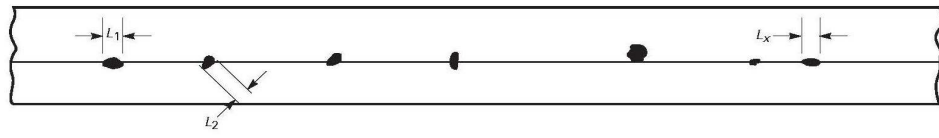
POI: IFA

Rev.: D0

DOCUMENT No: DPIC9812-000-VD-1002-ME-PRC-0070

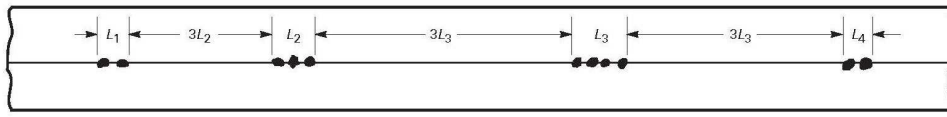
Sheet 46 of 57

Figure 4-1  
Aligned Rounded Indications



GENERAL NOTE: Sum of  $L_1$  to  $L_x$  shall be less than  $t$  in a length of  $12t$ .



Figure 4-2  
Groups of Aligned Rounded Indications



Maximum Group Length  
 $L = 1/4$  in. (6 mm) for  $t$  less than  $3/4$  in. (19 mm)  
 $L = 1/3 t$  for  $t 3/4$  in. (19 mm) to  $2 1/4$  in. (57 mm)  
 $L = 3/4$  in. (19 mm) for  $t$  greater than  $2 1/4$  in. (57 mm)

Minimum Group Spacing  
 $3L$  where  $L$  is the length of the longest adjacent group being evaluated

GENERAL NOTE: Sum of the group lengths shall be less than  $t$  in a length of  $12t$ .

	<b>DEHDASHT PETROCHEMICAL INDUSTRY COMPANY</b>  <b>DEHDASHT HIGH DENSITY POLYETHYLENE PROJECT</b>		
<b>Contract No.: DPIC/98-12</b>	<b>DOCUMENT TITLE: NDE Procedure</b>	<b>POI: IFA</b>	<b>Rev.: D0</b>
	<b>DOCUMENT No: DPIC9812-000-VD-1002-ME-PRC-0070</b>	<b>Sheet 47 of 57</b>	

(d) *Aligned Rounded Indications.* Aligned rounded indications are acceptable when the summation of the diameters of the indications is less than  $t$  in a length of  $12t$ . See Figure 4-1. The length of groups of aligned rounded indications and the spacing between the groups shall meet the requirements of Figure 4-2.

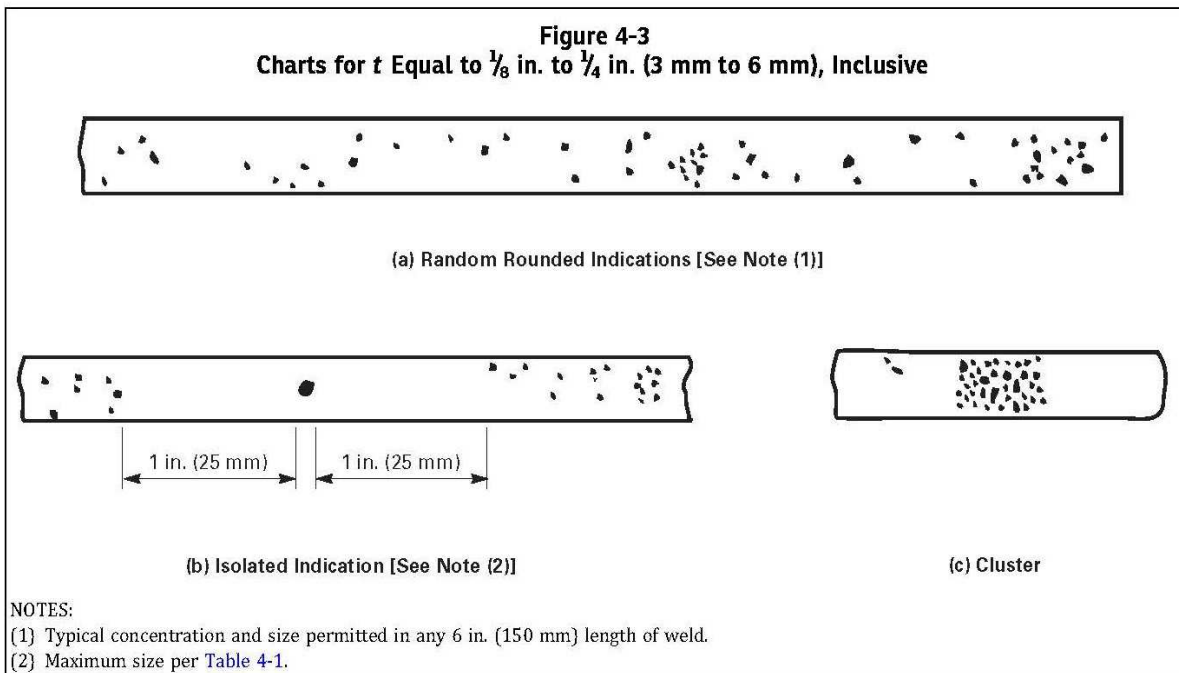
(e) *Spacing.* The distance between adjacent rounded indications is not a factor in determining acceptance or rejection, except as required for isolated indications or groups of aligned indications.

(f) *Rounded Indication Charts.* The rounded indications characterized as imperfections shall not exceed that shown in the charts. The charts in Figures 4-3 through 4-8 illustrate various types of assorted, randomly dispersed and clustered rounded indications for different weld thicknesses greater than  $\frac{1}{8}$  in. (3 mm). These charts represent the maximum acceptable concentration limits for rounded indications. The charts for each thickness range represent full-scale 6 in. (150 mm) radiographs,

and shall not be enlarged or reduced. The distributions shown are not necessarily the patterns that may appear on the radiograph, but are typical of the concentration and size of indications permitted.

(g) *Weld Thickness  $t$  Less Than  $\frac{1}{8}$  in. (3 mm).* For  $t$  less than  $\frac{1}{8}$  in. (3 mm) the maximum number of rounded indications shall not exceed 12 in a 6 in. (150 mm) length of weld. A proportionally fewer number of indications shall be permitted in welds less than 6 in. (150 mm) in length.

(h) *Clustered Indications.* The illustrations for clustered indications show up to four times as many indications in a local area, as that shown in the illustrations for random indications. The length of an acceptable cluster shall not exceed the lesser of 1 in. (25 mm) or  $2t$ . Where more than one cluster is present, the sum of the lengths of the clusters shall not exceed 1 in. (25 mm) in a 6 in. (150 mm) length weld.

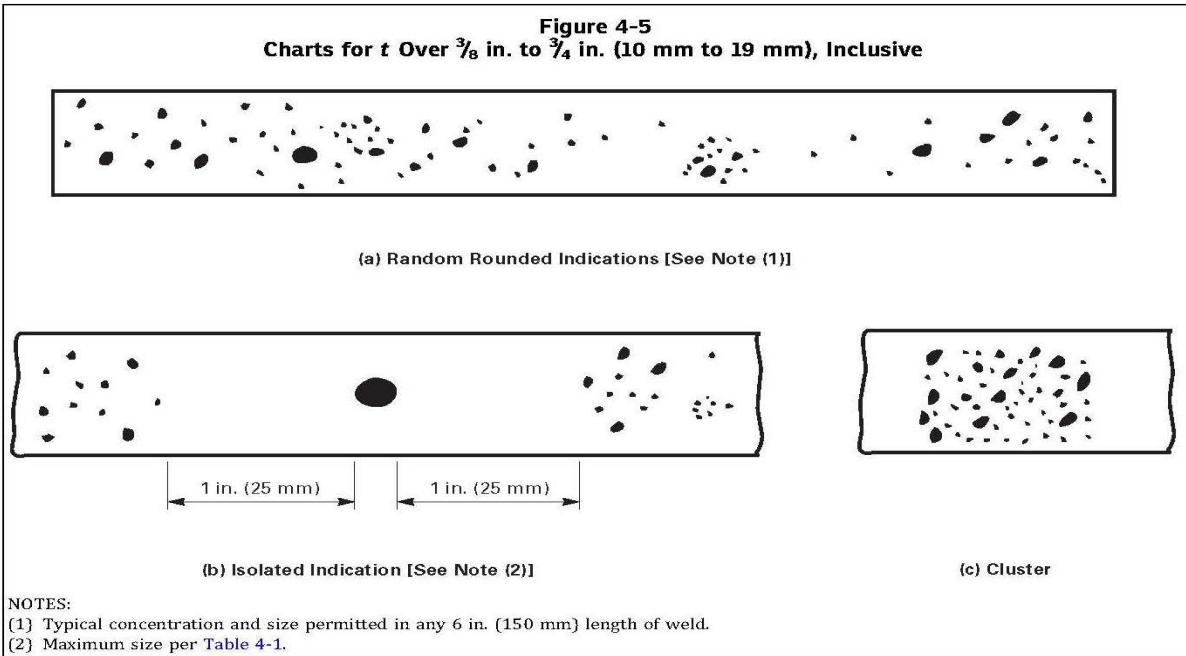
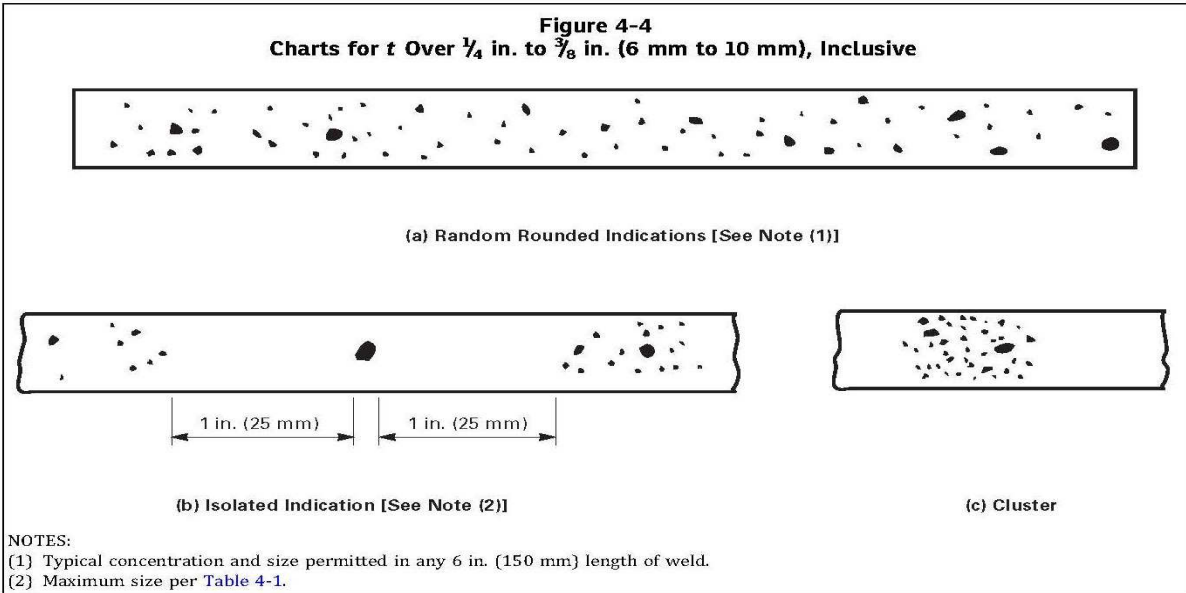




DEHDASHT PETROCHEMICAL INDUSTRY COMPANY  
 DEHDASHT HIGH DENSITY POLYETHYLENE PROJECT



Contract No.: DPIC/98-12	DOCUMENT TITLE: NDE Procedure	POI: IFA	Rev.: D0
	DOCUMENT No: DPIC9812-000-VD-1002-ME-PRC-0070	Sheet 48 of 57	



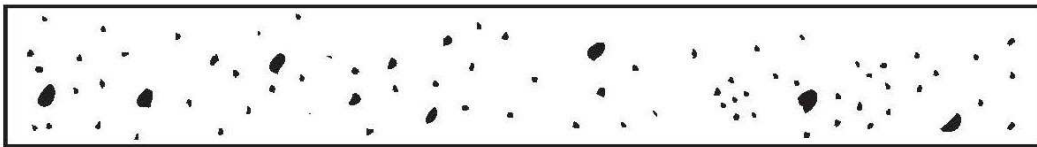


**DEHDASHT PETROCHEMICAL INDUSTRY COMPANY**  
**DEHDASHT HIGH DENSITY POLYETHYLENE PROJECT**

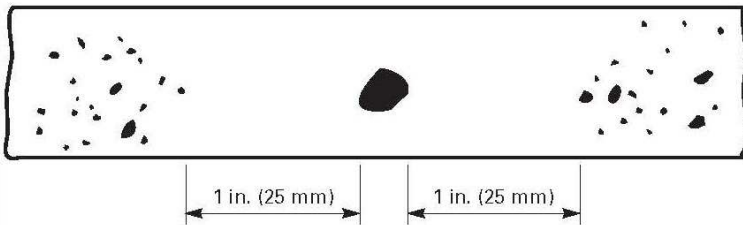


Contract No.: DPIC/98-12	DOCUMENT TITLE: NDE Procedure	POI: IFA	Rev.: D0
	DOCUMENT No: DPIC9812-000-VD-1002-ME-PRC-0070	Sheet 49 of 57	

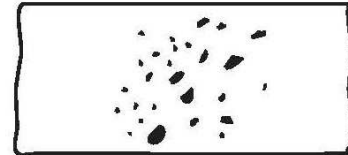
**Figure 4-6**  
**Charts for t Over 3/4 in. to 2 in. (19 mm to 50 mm), Inclusive**



(a) Random Rounded Indications [See Note (1)]



(b) Isolated Indication [See Note (2)]



(c) Cluster

**NOTES:**

- (1) Typical concentration and size permitted in any 6 in. (150 mm) length of weld.
- (2) Maximum size per Table 4-1.

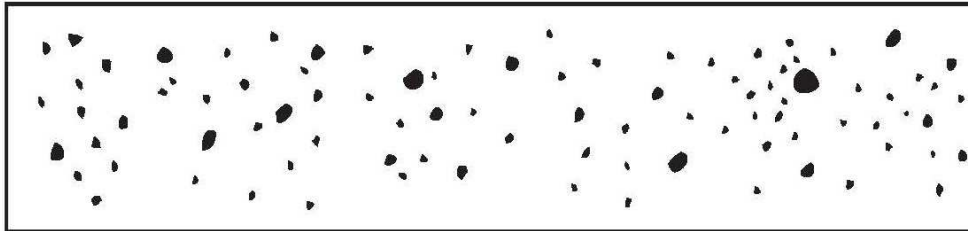


**DEHDASHT PETROCHEMICAL INDUSTRY COMPANY**  
**DEHDASHT HIGH DENSITY POLYETHYLENE PROJECT**

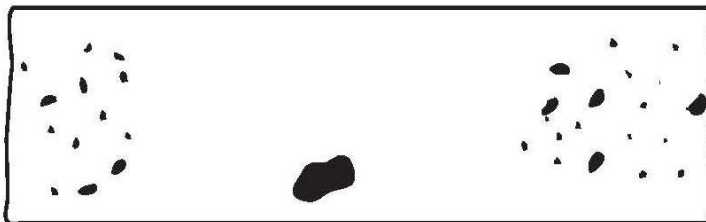


Contract No.: DPIC/98-12	DOCUMENT TITLE: NDE Procedure	POI: IFA	Rev.: D0
	DOCUMENT No: DPIC9812-000-VD-1002-ME-PRC-0070	Sheet 50 of 57	

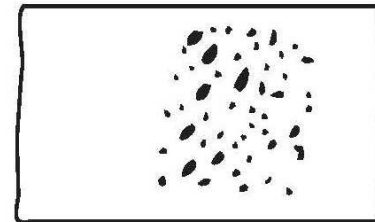
**Figure 4-7**  
**Charts for t Over 2 in. to 4 in. (50 mm to 100 mm), Inclusive**



(a) Random Rounded Indications [See Note (1)]



(b) Isolated Indication [See Note (2)]



(c) Cluster

**NOTES:**

- (1) Typical concentration and size permitted in any 6 in. (150 mm) length of weld.
- (2) Maximum size per Table 4-1.

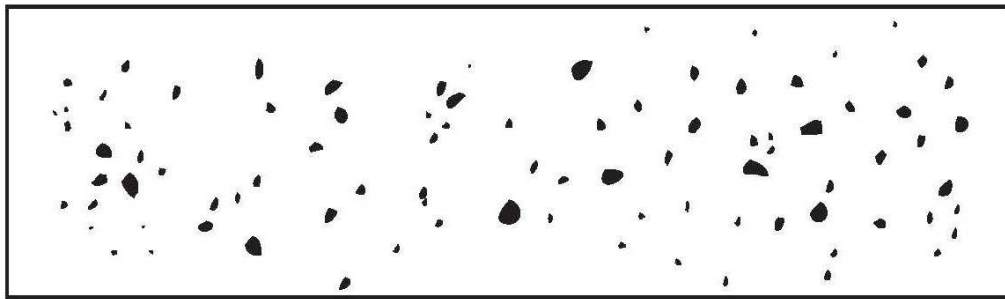


**DEHDASHT PETROCHEMICAL INDUSTRY COMPANY**  
**DEHDASHT HIGH DENSITY POLYETHYLENE PROJECT**

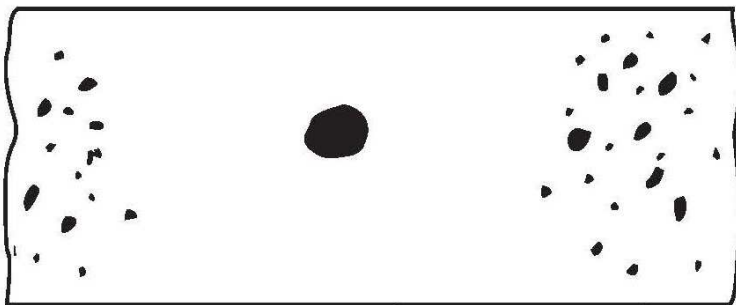


Contract No.: DPIC/98-12	DOCUMENT TITLE: NDE Procedure	POI: IFA	Rev.: D0
	DOCUMENT No: DPIC9812-000-VD-1002-ME-PRC-0070	Sheet 51 of 57	

**Figure 4-8**  
**Charts for  $t$  Over 4 in. (100 mm)**

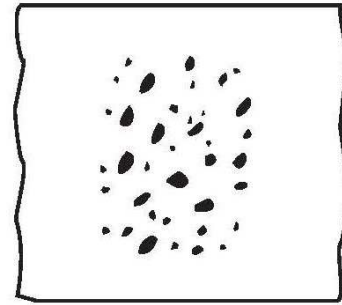


(a) Random Rounded Indications [See Note (1)]



1 in. (25 mm)      1 in. (25 mm)



(b) Isolated Indication [See Note (2)]



(c) Cluster

**NOTES:**

- (1) Typical concentration and size permitted in any 6 in. (150 mm) length of weld.
- (2) Maximum size per Table 4-1.

	<p style="text-align: center;"><b>DEHDASHT PETROCHEMICAL INDUSTRY COMPANY</b></p> <p style="text-align: center;"><b>DEHDASHT HIGH DENSITY POLYETHYLENE PROJECT</b></p>		
<p>Contract No.: DPIC/98-12</p>	<p>DOCUMENT TITLE: NDE Procedure</p>	<p>POI: IFA</p>	<p>Rev.: D0</p>
	<p>DOCUMENT No: DPIC9812-000-VD-1002-ME-PRC-0070</p>	<p style="text-align: center;">Sheet 52 of 57</p>	

## 2. ASME SEC VIII-Div.1, APPENDIX 8

### MANDATORY APPENDIX 8 METHODS FOR LIQUID PENETRANT EXAMINATION (PT)

NOTE: Satisfactory application of this method of examination requires special skills in the techniques involved and in interpreting the results. The requirements specified herein presume application by suitably experienced personnel.

#### 8-1 SCOPE

(a) This Appendix describes methods which shall be employed whenever liquid penetrant examination is specified in this Division.

(b) Article 6 of Section V shall be applied for detail requirements in methods and procedures, unless otherwise specified within this Appendix.

(c) Liquid penetrant examination shall be performed in accordance with a written procedure, certified by the Manufacturer to be in accordance with the requirements of T-150 of Section V.

(d) Documentation showing that the required examinations have been performed and that the results are acceptable shall be made available to the Inspector.

#### 8-2 CERTIFICATION OF COMPETENCY OF NONDESTRUCTIVE EXAMINATION PERSONNEL

The manufacturer shall certify that each liquid penetrant examiner meets the following requirements.

(a) He has vision, with correction if necessary, to enable him to read a Jaeger Type No. 2 Standard Chart at a distance of not less than 12 in. (300 mm), and is capable of distinguishing and differentiating contrast between colors used. These requirements shall be checked annually.

(b) He is competent in the techniques of the liquid penetrant examination method for which he is certified, including making the examination and interpreting and evaluating the results, except that, where the examination method consists of more than one operation, he may be certified as being qualified only for one or more of these operations.

#### 8-3 EVALUATION OF INDICATIONS

An indication of an imperfection may be larger than the imperfection that causes it; however, the size of the indication is the basis for acceptance evaluation. Only indications with major dimensions greater than  $1/16$  in. (1.5 mm) shall be considered relevant.

(a) A linear indication is one having a length greater than three times the width.

(b) A rounded indication is one of circular or elliptical shape with the length equal to or less than three times the width.

(c) Any questionable or doubtful indications shall be reexamined to determine whether or not they are relevant.

#### 8-4 ACCEPTANCE STANDARDS

These acceptance standards shall apply unless other more restrictive standards are specified for specific materials or applications within this Division.

All surfaces to be examined shall be free of:

(a) relevant linear indications;



(b) relevant rounded indications greater than  $3/16$  in. (5 mm);

(c) four or more relevant rounded indications in a line separated by  $1/16$  in. (1.5 mm) or less (edge to edge).

#### 8-5 REPAIR REQUIREMENTS

Unacceptable imperfections shall be repaired and reexamination made to assure removal or reduction to an acceptable size. Whenever an imperfection is repaired by chipping or grinding and subsequent repair by welding is not required, the excavated area shall be blended into the surrounding surface so as to avoid sharp notches, crevices, or corners. Where welding is required after repair of an imperfection, the area shall be cleaned and welding performed in accordance with a qualified welding procedure.



(a) *Treatment of Indications Believed Nonrelevant.* Any indication which is believed to be nonrelevant shall be regarded as an imperfection unless it is shown by reexamination by the same method or by the use of other nondestructive methods and/or by surface conditioning that no unacceptable imperfection is present.

	<b>DEHDASHT PETROCHEMICAL INDUSTRY COMPANY</b>  <b>DEHDASHT HIGH DENSITY POLYETHYLENE PROJECT</b>		
<b>Contract No.: DPIC/98-12</b>	<b>DOCUMENT TITLE: NDE Procedure</b>	<b>POI: IFA</b>	<b>Rev.: D0</b>
	<b>DOCUMENT No: DPIC9812-000-VD-1002-ME-PRC-0070</b>	<b>Sheet 53 of 57</b>	

*(b) Examination of Areas From Which Defects Have Been Removed.* After a defect is thought to have been removed and prior to making weld repairs, the area shall be examined by suitable methods to ensure it has been removed or reduced to an acceptably sized imperfection.

*(c) Reexamination of Repair Areas.* After repairs have been made, the repaired area shall be blended into the surrounding surface so as to avoid sharp notches,

crevices, or corners and reexamined by the liquid penetrant method and by all other methods of examination that were originally required for the affected area, except that, when the depth of repair is less than the radiographic sensitivity required, reradiography may be omitted.

	<b>DEHDASHT PETROCHEMICAL INDUSTRY COMPANY</b>  <b>DEHDASHT HIGH DENSITY POLYETHYLENE PROJECT</b>		
<b>Contract No.: DPIC/98-12</b>	<b>DOCUMENT TITLE: NDE Procedure</b>	<b>POI: IFA</b>	<b>Rev.: D0</b>
	<b>DOCUMENT No: DPIC9812-000-VD-1002-ME-PRC-0070</b>	<b>Sheet 54 of 57</b>	

### 3. ASME SEC VIII-Div.1, APPENDIX 12

## MANDATORY APPENDIX 12 ULTRASONIC EXAMINATION OF WELDS (UT)

### 12-1 SCOPE

(a) This Appendix describes methods which shall be employed when ultrasonic examination of welds is specified in this Division.

(b) Article 4 of Section V shall be applied for detail requirements in methods and procedures, unless otherwise specified in this Appendix.

(c) Ultrasonic examination shall be performed in accordance with a written procedure, certified by the Manufacturer to be in accordance with the requirements of T-150 of Section V.

### 12-2 CERTIFICATION OF COMPETENCE OF NONDESTRUCTIVE EXAMINER

Personnel performing and evaluating ultrasonic examinations required by this Division shall meet the requirements of UW-54.

### 12-3 ACCEPTANCE-REJECTION STANDARDS

These Standards shall apply unless other standards are specified for specific applications within this Division.

Imperfections which produce a response greater than 20% of the reference level shall be investigated to the extent that the operator can determine the shape, identity, and location of all such imperfections and evaluate them in terms of the acceptance standards given in (a) and (b) below.

(a) Indications characterized as cracks, lack of fusion, or incomplete penetration are unacceptable regardless of length.



(b) Other imperfections are unacceptable if the indications exceed the reference level amplitude and have lengths which exceed:

- (1)  $\frac{1}{4}$  in. (6 mm) for  $t$  up to  $\frac{3}{4}$  in. (19 mm);
- (2)  $\frac{1}{3}t$  for  $t$  from  $\frac{3}{4}$  in. to  $2\frac{1}{4}$  in. (19 mm to 57 mm);
- (3)  $\frac{3}{4}$  in. (19 mm) for  $t$  over  $2\frac{1}{4}$  in. (57 mm).

where  $t$  is the thickness of the weld excluding any allowable reinforcement. For a butt weld joining two members having different thicknesses at the weld,  $t$  is the thinner of these two thicknesses. If a full penetration weld includes a fillet weld, the thickness of the throat of the fillet shall be included in  $t$ .

### 12-4 REPORT OF EXAMINATION

The Manufacturer shall prepare a report of the ultrasonic examination and a copy of this report shall be retained by the Manufacturer as required by this Division (10-13). The report shall contain the information required by Section V. In addition, a record of repaired areas shall be noted as well as the results of the reexamination of the repaired areas. The Manufacturer shall also maintain a record of all reflections from uncorrected areas having responses that exceed 50% of the reference level. This record shall locate each area, the response level, the dimensions, the depth below the surface, and the classification.

	<p style="text-align: center;"><b>DEHDASHT PETROCHEMICAL INDUSTRY COMPANY</b></p> <p style="text-align: center;"><b>DEHDASHT HIGH DENSITY POLYETHYLENE PROJECT</b></p>		
<p>Contract No.: DPIC/98-12</p>	<p>DOCUMENT TITLE: NDE Procedure</p>	<p>POI: IFA</p>	<p>Rev.: D0</p>
	<p>DOCUMENT No: DPIC9812-000-VD-1002-ME-PRC-0070</p>	<p style="text-align: center;">Sheet 55 of 57</p>	

## UW-51 RADIOGRAPHIC EXAMINATION OF WELDED JOINTS

(a) All welded joints to be radiographed shall be examined in accordance with Article 2 of Section V except as specified below.

(1) A complete set of radiographs and records, as described in Article 2 of Section V, for each vessel or vessel part shall be retained by the Manufacturer, as follows:

(-a) films until the Manufacturer's Data Report has been signed by the Inspector;

(-b) records as required by this Division (10-13).

(2) A written radiographic examination procedure is not required. Demonstration of density and penetrameter image requirements on production or technique radiographs shall be considered satisfactory evidence of compliance with Article 2 of Section V.

(3) The requirements of T-274.2 of Article 2 of Section V are to be used only as a guide. Final acceptance of radiographs shall be based on the ability to see the prescribed penetrameter image and the specified hole or the designated wire of a wire penetrameter.

(4) As an alternative to the radiographic examination requirements above, all welds in material  $\frac{1}{4}$  in. (6 mm) and greater in thickness may be examined using the ultrasonic (UT) method per the requirements of 7.5.5 of Section VIII, Division 2.

(b) Indications shown on the radiographs of welds and characterized as imperfections are unacceptable under the following conditions and shall be repaired as provided in UW-38, and the repair radiographed to UW-51 or, at the option of the Manufacturer, ultrasonically examined in accordance with the method described in **Mandatory Appendix 12** and the standards specified in this paragraph, provided the defect has been confirmed by the ultrasonic examination to the satisfaction of the Authorized Inspector prior to making the repair. For material thicknesses in excess of 1 in. (25 mm), the concurrence of the user shall be obtained. This ultrasonic examination shall be noted under Remarks on the Manufacturer's Data Report Form:

(1) any indication characterized as a crack or zone of incomplete fusion or penetration;



(2) any other elongated indication on the radiograph which has length greater than:

(-a)  $\frac{1}{4}$  in. (6 mm) for  $t$  up to  $\frac{3}{4}$  in. (19 mm)

(-b)  $\frac{1}{3}t$  for  $t$  from  $\frac{3}{4}$  in. (19 mm) to  $2\frac{1}{4}$  in. (57 mm)

(-c)  $\frac{3}{4}$  in. (19 mm) for  $t$  over  $2\frac{1}{4}$  in. (57 mm)

where

	<b>DEHDASHT PETROCHEMICAL INDUSTRY COMPANY</b>  <b>DEHDASHT HIGH DENSITY POLYETHYLENE PROJECT</b>		
<b>Contract No.: DPIC/98-12</b>	<b>DOCUMENT TITLE: NDE Procedure</b>	<b>POI: IFA</b>	<b>Rev.: D0</b>
	<b>DOCUMENT No: DPIC9812-000-VD-1002-ME-PRC-0070</b>	<b>Sheet 56 of 57</b>	

$t$  = the thickness of the weld excluding any allowable reinforcement. For a butt weld joining two members having different thicknesses at the weld,  $t$  is the thinner of these two thicknesses. If a full penetration weld includes a fillet weld, the thickness of the throat of the fillet shall be included in  $t$ .

(3) any group of aligned indications that have an aggregate length greater than  $t$  in a length of  $12t$ , except when the distance between the successive imperfections exceeds  $6L$  where  $L$  is the length of the longest imperfection in the group;

(4) rounded indications in excess of that specified by the acceptance standards given in [Mandatory Appendix 4](#).

#### UW-52 SPOT EXAMINATION OF WELDED JOINTS

NOTE: Spot radiographing of a welded joint is recognized as an effective inspection tool. The spot radiography rules are also considered to be an aid to quality control. Spot radiographs made directly after a welder or an operator has completed a unit of weld proves that the work is or is not being done in accordance with a satisfactory procedure. If the work is unsatisfactory, corrective steps can then be taken to improve the welding in the subsequent units, which unquestionably will improve the weld quality.

Spot radiography in accordance with these rules will not ensure a fabrication product of predetermined quality level throughout. It must be realized that an accepted vessel under these spot radiography rules may still contain defects which might be disclosed on further examination. If all radiographically disclosed weld defects must be eliminated from a vessel, then 100% radiography must be employed.

(a) Butt welded joints which are to be spot radiographed shall be examined locally as provided herein.

(b) *Minimum Extent of Spot Radiographic Examination*

(1) One spot shall be examined on each vessel for each 50 ft (15 m) increment of weld or fraction thereof for which a joint efficiency from column (b) of [Table UW-12](#) is selected. However, for identical vessels or parts, each with less than 50 ft (15 m) of weld for which a joint efficiency from column (b) of [Table UW-12](#) is selected, 50 ft (15 m) increments of weld may be represented by one spot examination.

(2) For each increment of weld to be examined, a sufficient number of spot radiographs shall be taken to examine the welding of each welder or welding operator. Under conditions where two or more welders or welding operators make weld layers in a joint, or on the two sides of a double-welded butt joint, one spot may represent the work of all welders or welding operators.

(3) Each spot examination shall be made as soon as practicable after completion of the increment of weld to be examined. The location of the spot shall be chosen by the Inspector after completion of the increment of welding to be examined, except that when the Inspector has been notified in advance and cannot be present or otherwise make the selection, the Manufacturer may exercise his own judgment in selecting the spots.

(4) Radiographs required at specific locations to satisfy the rules of other paragraphs, such as [UW-9\(d\)](#), [UW-11\(a\)\(5\)\(-b\)](#), and [UW-14\(b\)](#), shall not be used to satisfy the requirements for spot radiography.

(c) *Standards for Spot Radiographic Examination.* Spot examination by radiography shall be made in accordance with the technique prescribed in [UW-51\(a\)](#). The minimum length of spot radiograph shall be 6 in. (150 mm). Spot radiographs may be retained or be discarded by the Manufacturer after acceptance of the vessel by the Inspector. The acceptability of welds examined by spot radiography shall be judged by the following standards:

(1) Welds in which indications are characterized as cracks or zones of incomplete fusion or penetration shall be unacceptable.

(2) Welds having indications characterized as slag inclusions or cavities are unacceptable when the indication length exceeds  $\frac{2}{3}t$ , where  $t$  is defined as shown in [UW-51\(b\)\(2\)](#). For all thicknesses, indications less than  $\frac{1}{4}$  in. (6 mm) are acceptable, and indications greater than  $\frac{3}{4}$  in. (19 mm) are unacceptable. Multiple aligned indications meeting these acceptance criteria are acceptable when the sum of their longest dimensions indications does not exceed  $t$  within a length of  $6t$  (or proportionally for radiographs shorter than  $6t$ ), and when the longest length  $L$  for each indication is separated by a distance not less than  $3L$  from adjacent indications.

(3) Rounded indications are not a factor in the acceptability of welds not required to be fully radiographed.



(d) *Evaluation and Retests*

(1) When a spot, radiographed as required in (b)(1) or (b)(2) above, is acceptable in accordance with (c)(1) and (c)(2) above, the entire weld increment represented by this radiograph is acceptable.

(2) When a spot, radiographed as required in (b)(1) or (b)(2) above, has been examined and the radiograph discloses welding which does not comply with the minimum quality requirements of (c)(1) or (c)(2) above, two additional spots shall be radiographically examined in the same weld increment at locations away from the original spot. The locations of these additional spots shall be determined by the Inspector or fabricator as provided for the original spot examination in (b)(3) above.

(-a) If the two additional spots examined show welding which meets the minimum quality requirements of (c)(1) and (c)(2) above, the entire weld increment represented by the three radiographs is acceptable provided the defects disclosed by the first of the three radiographs are removed and the area repaired by welding. The weld repaired area shall be radiographically examined in accordance with the foregoing requirements of [UW-52](#).

(-b) If either of the two additional spots examined shows welding which does not comply with the minimum quality requirements of (c)(1) or (c)(2) above, the entire increment of weld represented shall be rejected. The entire rejected weld shall be removed and the joint shall be

	<b>DEHDASHT PETROCHEMICAL INDUSTRY COMPANY</b>  <b>DEHDASHT HIGH DENSITY POLYETHYLENE PROJECT</b>		
<b>Contract No.: DPIC/98-12</b>	<b>DOCUMENT TITLE: NDE Procedure</b>	<b>POI: IFA</b>	<b>Rev.: D0</b>
	<b>DOCUMENT No: DPIC9812-000-VD-1002-ME-PRC-0070</b>	<b>Sheet 57 of 57</b>	

rewelded or, at the fabricator's option, the entire increment of weld represented shall be completely radiographed and only defects need be corrected.

(-c) Repair welding shall be performed using a qualified procedure and in a manner acceptable to the Inspector. The rewelded joint, or the weld repaired areas, shall be spot radiographically examined at one location in accordance with the foregoing requirements of [UW-52](#).