

	<b>DEHDASHT PETROCHEMICAL INDUSTRY COMPANY</b> <b>DEHDASHT HIGH DENSITY POLYETHYLENE PROJECT</b>	
	<b>DOCUMENT TITLE: Liquid Receiver Data Sheet</b>	<b>POI: IFA</b>
<b>Contract No.: DPIC/98-12</b>	<b>DOCUMENT NUMBER: DPIC9812-000-VD-1002-ME-DS-0081</b>	<b>Rev. No.: D1</b>

**DOCUMENT TITLE:**

**Liquid Receiver Data Sheet  
(D-PK6101-2)**

This document is the property of PEDEC. Any unauthorized attempt to reproduce it, in any form, is strictly prohibited.

<b>PURCHASER'S COMMENT/APPROVAL STATUS</b>					Purchaser: NARGAN
1	AP: Approved (Released for Manufacturing)				Requisition No.: DPIC98-12-001-000-ME-MR-4150-0001-D1
<input checked="" type="checkbox"/>	AN: Approved With Minor Comments (Fabrication may Proceed)				
3	NF: Approved With Comments (Fabrication not Proceed)				Item No. (Tag No.): PK-6101
4	RJ: Rejected				
5	NR: Not be Returned				Vendor Doc. No.: DPIC9812-000-VD-1002-ME-DS-0081-D1
Date:		16.01.2022	Signature: A.AB		
					
D1	23.Dec..21	R.GOUDARZI	DR.A.NEJATI	DR.A.NEJATI	
D0	17.Nov..21	A.VOSOUGH	DR.A.NEJATI	DR.A.NEJATI	
<b>REV</b>	<b>DATE ISSUE</b>	<b>PREPARED</b>	<b>CHECKED</b>	<b>APPROVED</b>	



DEHDASHT PETROCHEMICAL INDUSTRY COMPANY

DEHDASHT HIGH DENSITY POLYETHYLENE PROJECT



DOCUMENT TITLE: Liquid Receiver Data Sheet

POI: IFA

Contract No.: DPIC/98-12

DOCUMENT NUMBER: DPIC9812-000-VD-1002-ME-DS-0081

Rev. No.: D1

Page	Rev-D0	Rev-D1	Rev-D2	Rev-D3	Rev-D4
1	x	x			
2	x	x			
3	x	x			
4	x	x			
5					
6					
7					
8					
9					
10					
11					
12					
13					
14					
15					
16					
17					
18					
19					
20					
21					
22					
23					
24					
25					
26					
27					
28					
29					
30					
31					
32					
33					
34					
35					

Page	Rev-D0	Rev-D1	Rev-D2	Rev-D3	Rev-D4
36					
37					
38					
39					
40					
41					
42					
43					
44					
45					
46					
47					
48					
49					
50					
51					
52					
53					
54					
55					
56					
57					
58					
59					
60					
61					
62					
63					
64					
65					
66					
67					
68					
69					
70					

This document is the property of PEDEC. Any unauthorized attempt to reproduce it, in any form, is strictly prohibited.





DEHDASHT PETROCHEMICAL INDUSTRY COMPANY  
DEHDASHT HIGH DENSITY POLYETHYLENE PROJECT



DOCUMENT TITLE: Liquid Receiver Data Sheet

POI: IFA

Contract No.: DPIC/98-12

DOCUMENT NUMBER: DPIC9812-000-VD-1002-ME-DS-0081

Rev. No.: D1

SKETCH

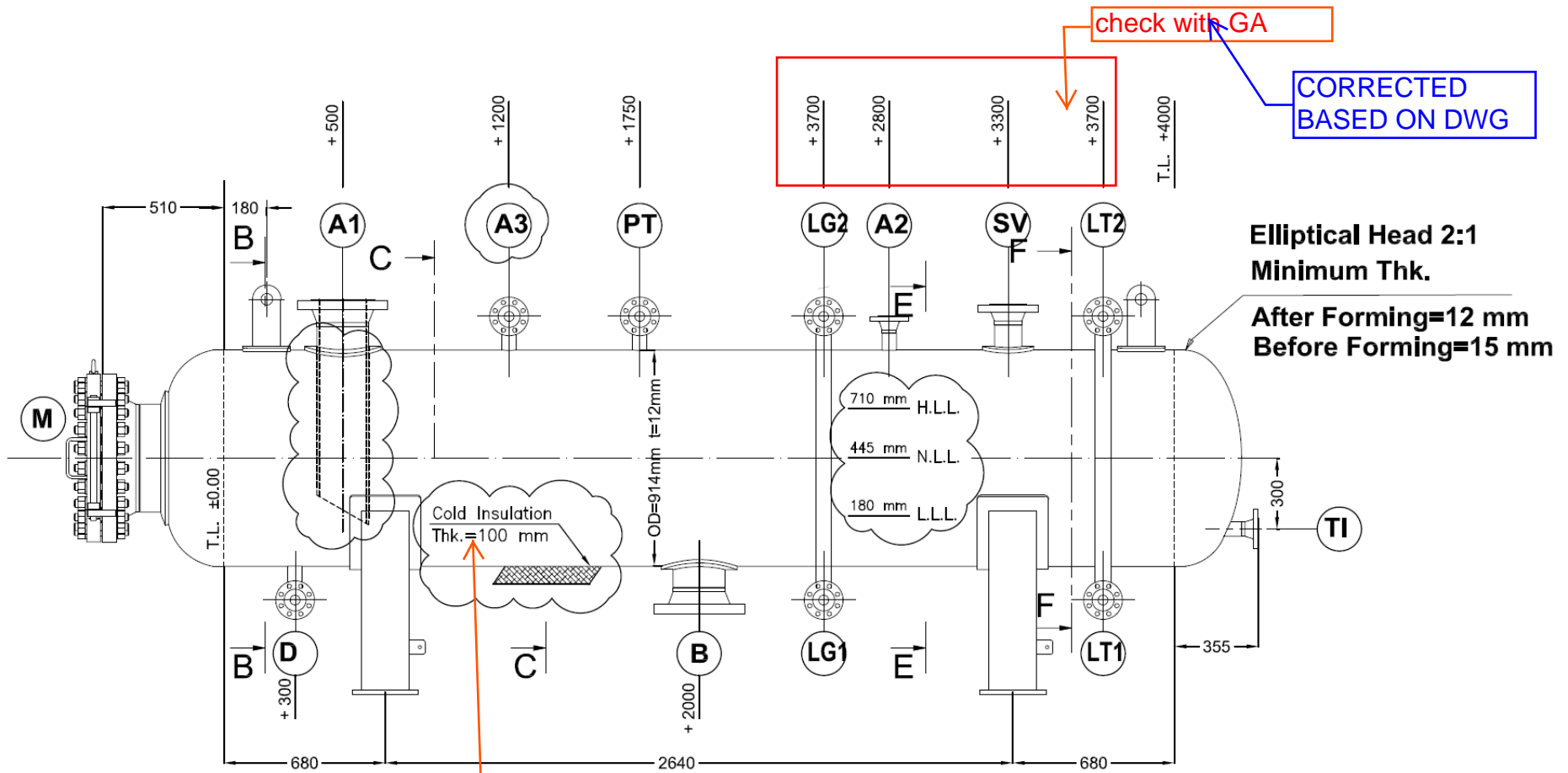

check with GA

CORRECTED BASED ON DWG

check with other doc

PLEASE COMMENT ON OTHER DOCUMENTS. IT IS OK IN THIS DATA SHEET

