



This document is the property of DPIC. Any unauthorized attempt to reproduce it, in any form, is strictly prohibited.

	DEHDASHT PETROCHEMICAL INDUSTRY COMPANY DEHDASHT HIGH DENSITY POLYETHYLENE PROJECT		
Contract No.: DPIC/98-12	DOCUMENT TITLE: Evaporator Drawing	POI: IFA	Rev.: D0
DOCUMENT No: DPIC9812-000-VD-1002-ME-DWG-0087		Sheet 1 of 3	

Evaporator Drawing (E-PK6101)

PURCHASER'S COMMENT/APPROVAL STATUS					
					Purchaser: NARGAN
1	AP: Approved (Released for Manufacturing)				
2	AN: Approved With Minor Comments (Fabrication may Proceed)				Requisition No.: DPIC98-12-001-000-ME-MR-4150-0001-D1
3	NF: Approved With Comments (Fabrication not Proceed)				
4	RJ: Rejected				Item No. (Tag No.): PK-6101
5	NR: Not be Returned				
Date: XX.XX.XX Signature:					Vendor Doc. No.: DPIC9812-000-VD-1002-ME-DWG-0087-D0
D0	23-DEC.-21	IFA	A.VOSOUGH	DR.A.NEJATI	DR.A.NEJATI
REV.	DATE ISSUE	Purpose of Issue	PREPARED	CHECKED	APPROVED





DEHDASHT PETROCHEMICAL INDUSTRY COMPANY
DEHDASHT HIGH DENSITY POLYETHYLENE PROJECT



Contract No.: DPIC/98-12

DOCUMENT TITLE: Evaporator Drawing

POI: IFA

Rev.: D0

DOCUMENT No: DPIC9812-000-VD-1002-ME-DWG-0087

Sheet 2 of 3

TABULATION OF REVISED PAGES

Page	Rev-D0	Rev-D1	Rev-D2	Rev-D3	Rev-D4
1	x				
2	x				
3	x				
4					
5					
6					
7					
8					
9					
10					
11					
12					
13					
14					
15					
16					
17					
18					
19					
20					
21					
22					
23					
24					
25					
26					
27					
28					
29					
30					
31					
32					
33					
34					
35					

Page	Rev-D0	Rev-D1	Rev-D2	Rev-D3	Rev-D4
36					
37					
38					
39					
40					
41					
42					
43					
44					
45					
46					
47					
48					
49					
50					
51					
52					
53					
54					
55					
56					
57					
58					
59					
60					
61					
62					
63					
64					
65					
66					
67					
68					
69					
70					

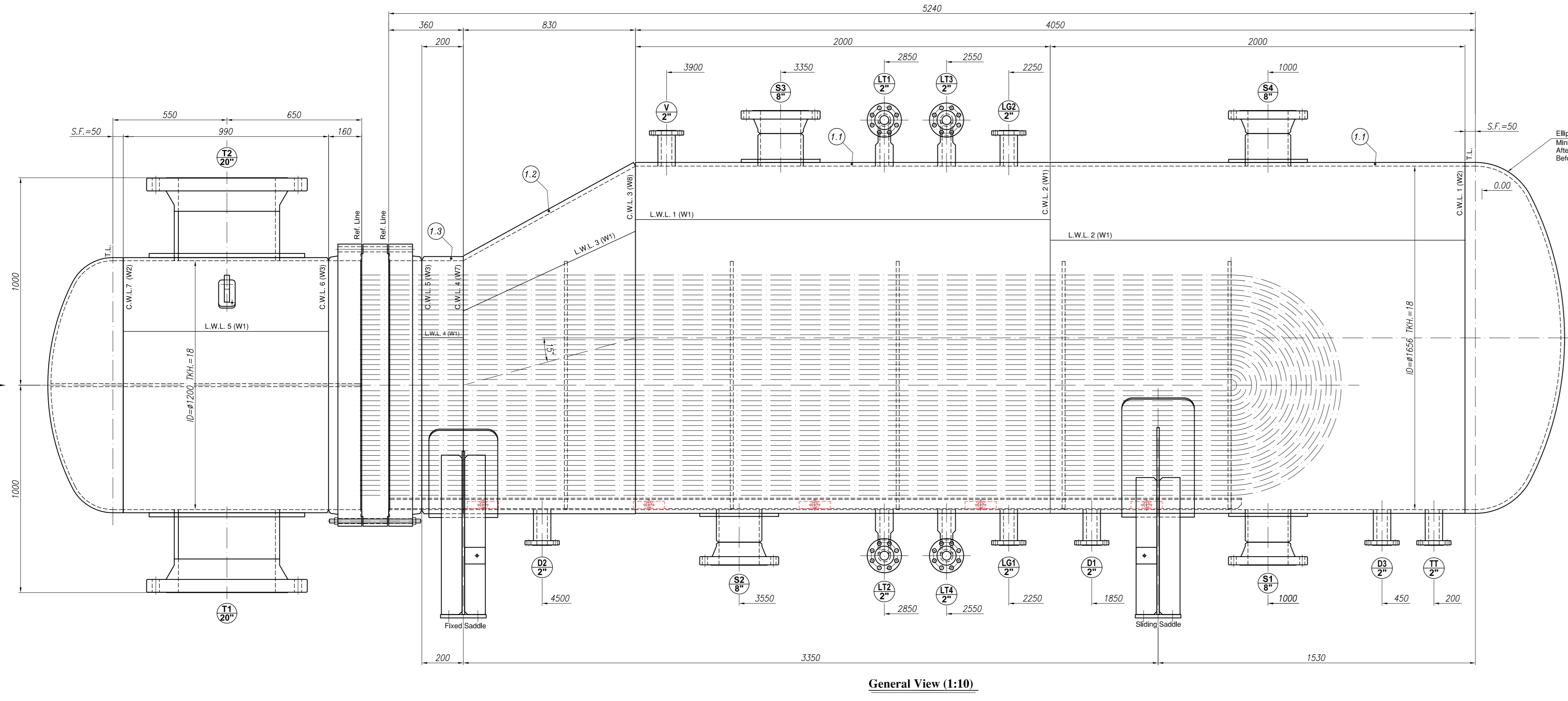

General View (1:10)

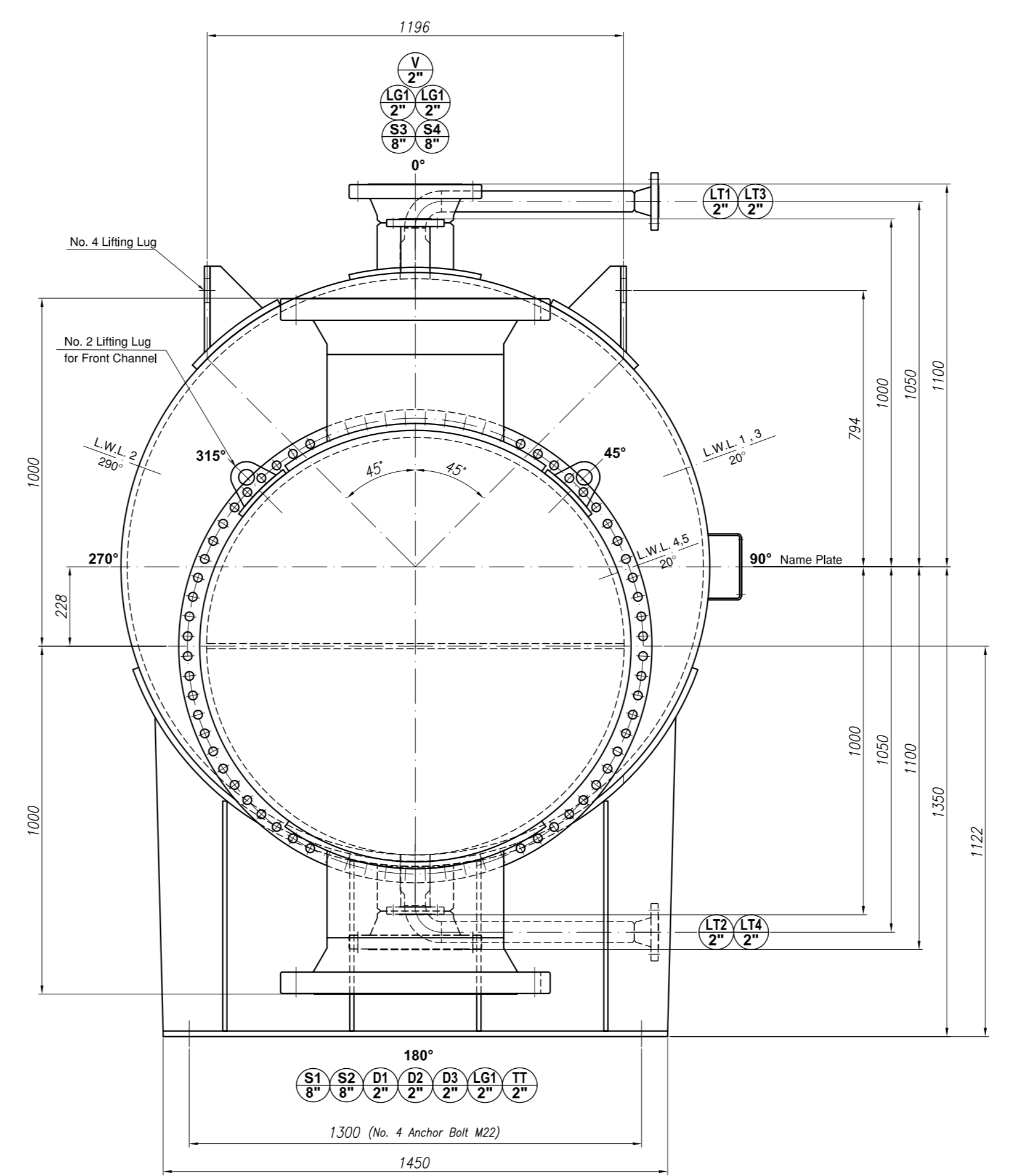

View "A" (1:10)

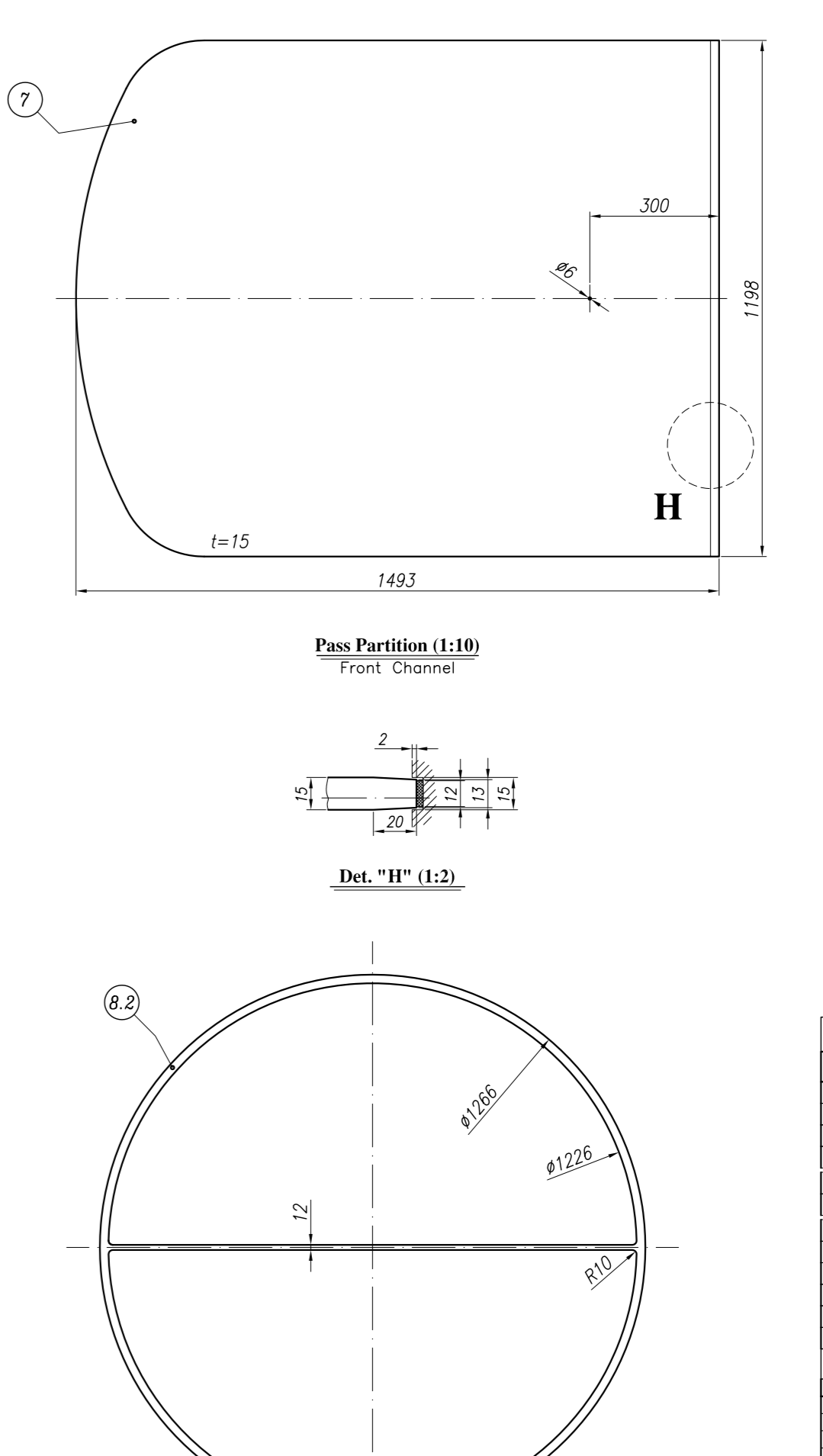

Front Gasket (1:10)

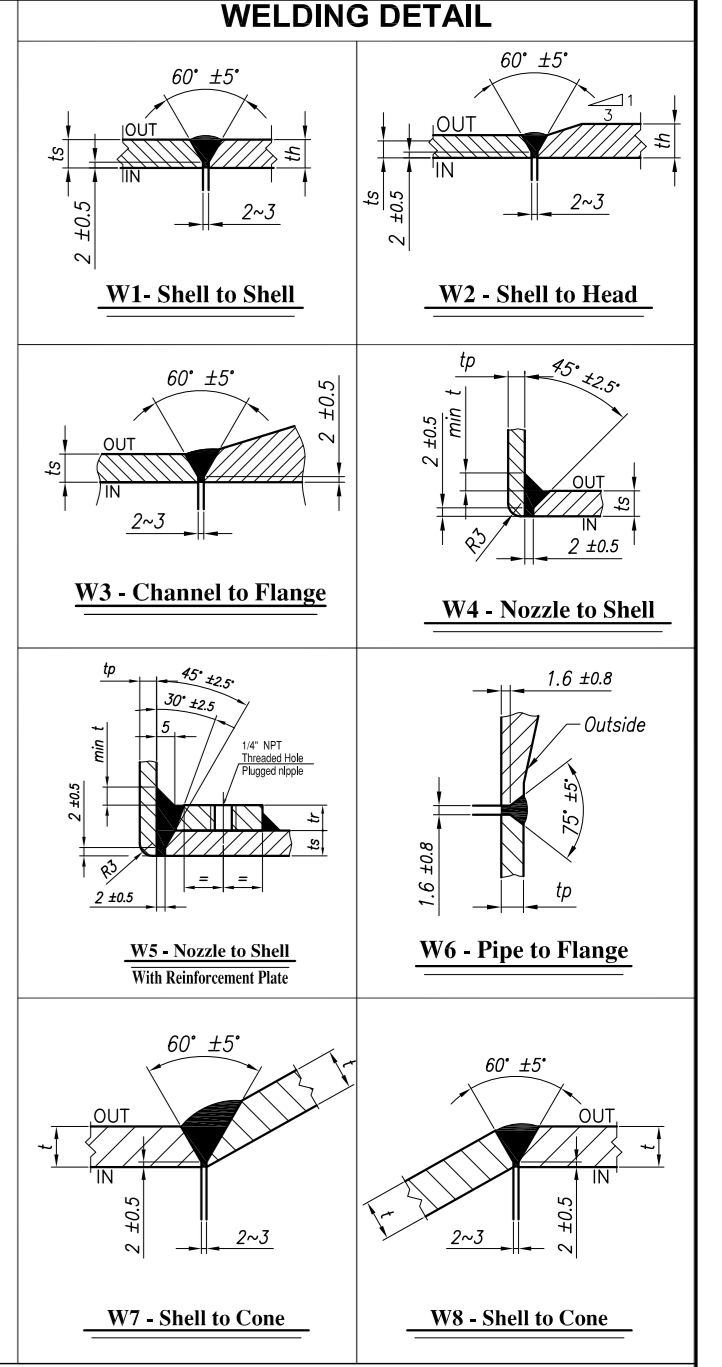

NOZZLE DATA											
NO.	SIZE	TYPE	ORIENT.	NO.	SIZE	TYPE	ORIENT.	NO.	SIZE	TYPE	ORIENT.
1	2"	SA 516 Gr. 70N	LN	1	2"	SA 516 Gr. 70N	LN	1	2"	SA 516 Gr. 70N	LN
2	2"	SA 516 Gr. 70N	LN	2	2"	SA 516 Gr. 70N	LN	2	2"	SA 516 Gr. 70N	LN
3	2"	SA 516 Gr. 70N	LN	3	2"	SA 516 Gr. 70N	LN	3	2"	SA 516 Gr. 70N	LN
4	2"	SA 516 Gr. 70N	LN	4	2"	SA 516 Gr. 70N	LN	4	2"	SA 516 Gr. 70N	LN
5	2"	SA 516 Gr. 70N	LN	5	2"	SA 516 Gr. 70N	LN	5	2"	SA 516 Gr. 70N	LN
6	2"	SA 516 Gr. 70N	LN	6	2"	SA 516 Gr. 70N	LN	6	2"	SA 516 Gr. 70N	LN
7	2"	SA 516 Gr. 70N	LN	7	2"	SA 516 Gr. 70N	LN	7	2"	SA 516 Gr. 70N	LN
8	2"	SA 516 Gr. 70N	LN	8	2"	SA 516 Gr. 70N	LN	8	2"	SA 516 Gr. 70N	LN
9	2"	SA 516 Gr. 70N	LN	9	2"	SA 516 Gr. 70N	LN	9	2"	SA 516 Gr. 70N	LN
10	2"	SA 516 Gr. 70N	LN	10	2"	SA 516 Gr. 70N	LN	10	2"	SA 516 Gr. 70N	LN
11	2"	SA 516 Gr. 70N	LN	11	2"	SA 516 Gr. 70N	LN	11	2"	SA 516 Gr. 70N	LN
12	2"	SA 516 Gr. 70N	LN	12	2"	SA 516 Gr. 70N	LN	12	2"	SA 516 Gr. 70N	LN
13	2"	SA 516 Gr. 70N	LN	13	2"	SA 516 Gr. 70N	LN	13	2"	SA 516 Gr. 70N	LN
14	2"	SA 516 Gr. 70N	LN	14	2"	SA 516 Gr. 70N	LN	14	2"	SA 516 Gr. 70N	LN

MAX. ALLOWABLE NOZZLE LOADS TABLE									
NOZZLE MARK NO.	NOZZLE SIZE	DIRECT LOADS (N)	MOMENT LOADS (N.M)	NO.	NOZZLE MARK NO.	NOZZLE SIZE	DIRECT LOADS (N)	MOMENT LOADS (N.M)	
1	2"	2000	1000	11	11	2"	2000	1000	
2	2"	2000	1000	12	12	2"	2000	1000	
3	2"	2000	1000	13	13	2"	2000	1000	
4	2"	2000	1000	14	14	2"	2000	1000	
5	2"	2000	1000	15	15	2"	2000	1000	
6	2"	2000	1000	16	16	2"	2000	1000	
7	2"	2000	1000	17	17	2"	2000	1000	
8	2"	2000	1000	18	18	2"	2000	1000	
9	2"	2000	1000	19	19	2"	2000	1000	
10	2"	2000	1000	20	20	2"	2000	1000	

GENERAL NOTES

- All dimensions are in millimeters unless otherwise noted.
- Projection of nozzles are measured from flange face to center line of vessel or flange face to T.L.
- Distances are measured from bottom flange unless otherwise specified.
- Both holes for flanges shall be welded to equipment main walls.
- Stagger thicknesses to minimum after forming thickness of elliptical heads.
- Customer material - Austenitic Metal Stainless Steel, grade 316L, 3mm Thk.
- Full radiographic examination shall be performed for nozzle necks made by date.
- Flange face finishing shall be smooth with 125 micro mesh minimum to 200 mesh maximum as per ASME B 1.9 for 2" and less. Also ASME B16.47 REFINED B for more than 2".
- Flange & mounting flanges and spacers shall be close to vendor.
- Test pressure calculated as per UG-99 (26).
- All steel bolts shall be supplied independent of ASME B31.3 TYPE 2.
- Painting: 70 Micron ZINCETHYL SILICATE UP TO 200C SA3 Surface Per Partion SA3.
- ASME Section VIII, Div. 1, UG-110 is to be used for the calculation of stress and load based required.

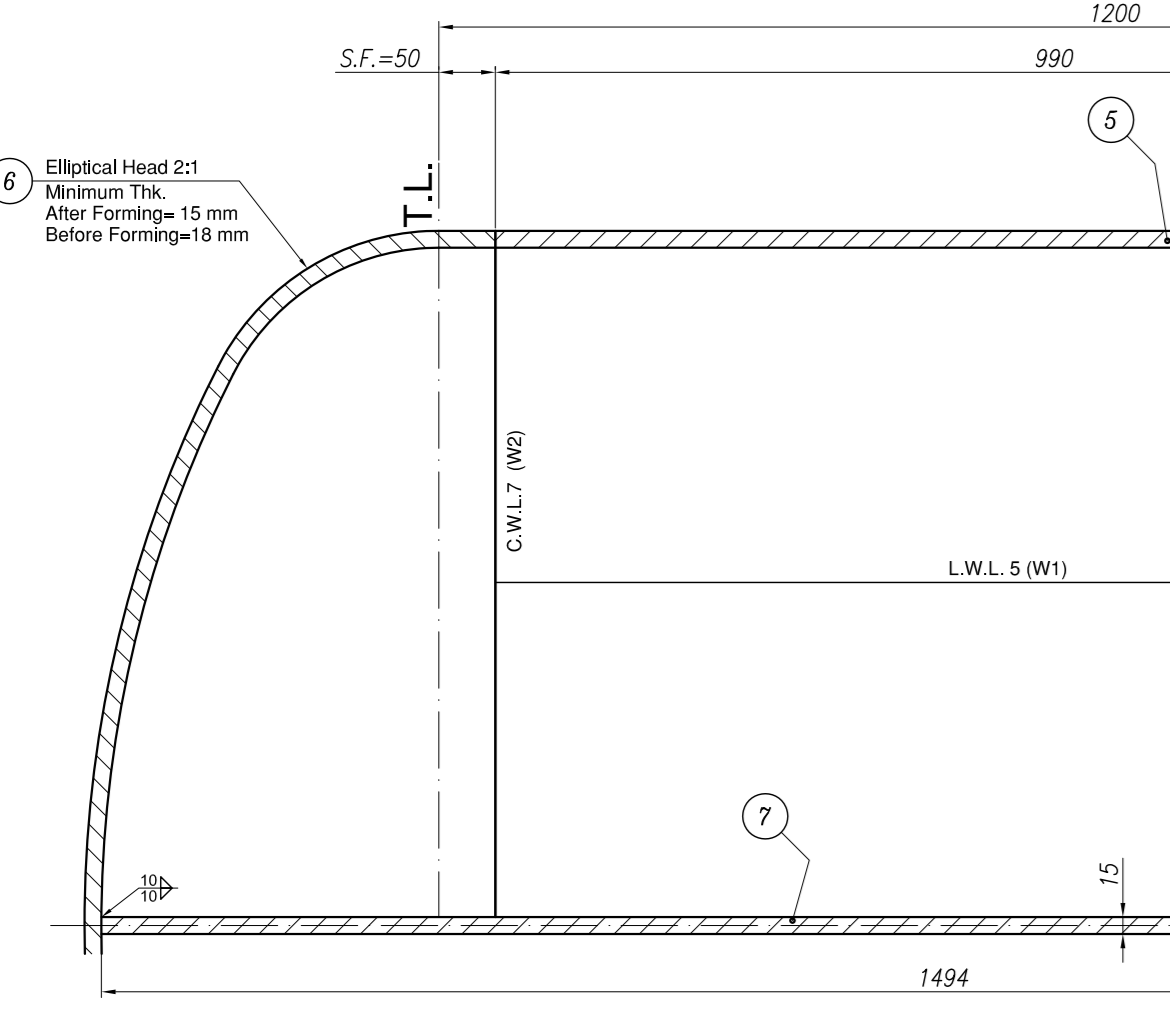

Front Head (1:5)

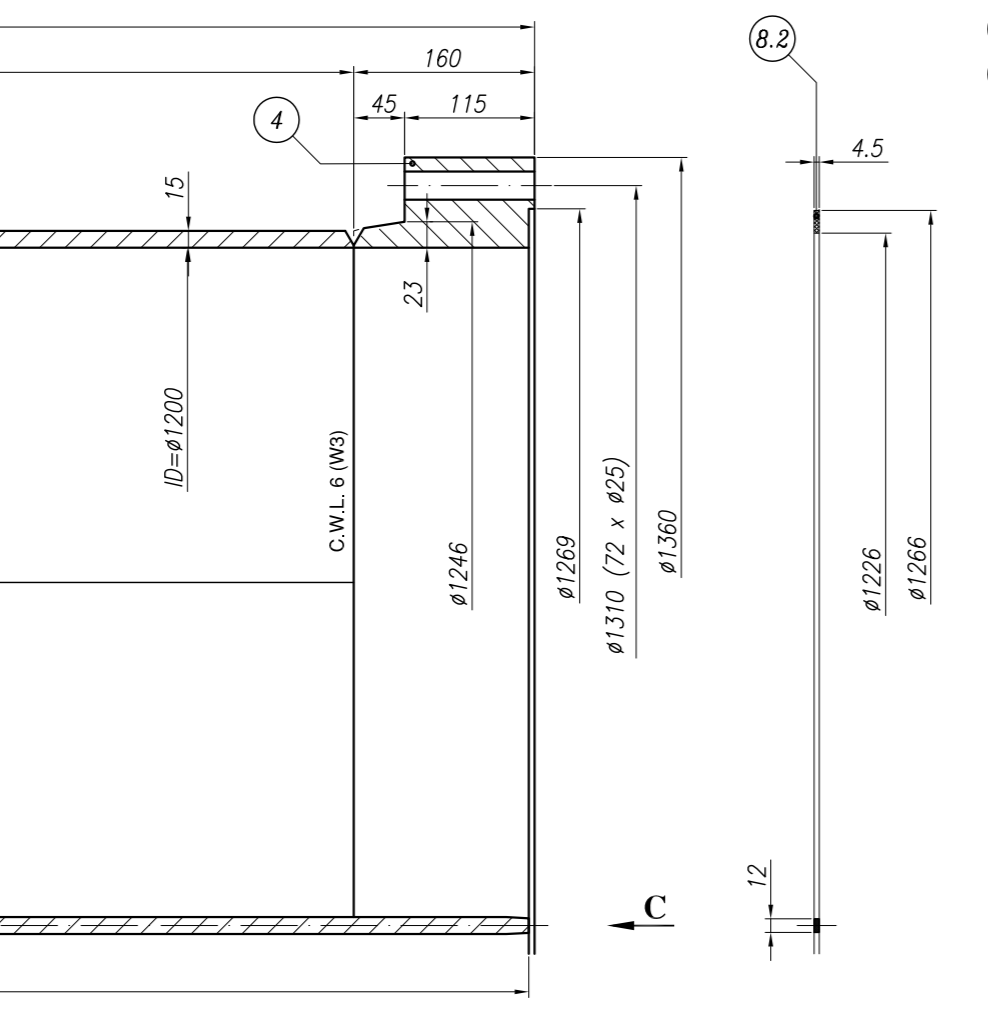

Gasket (1:5)

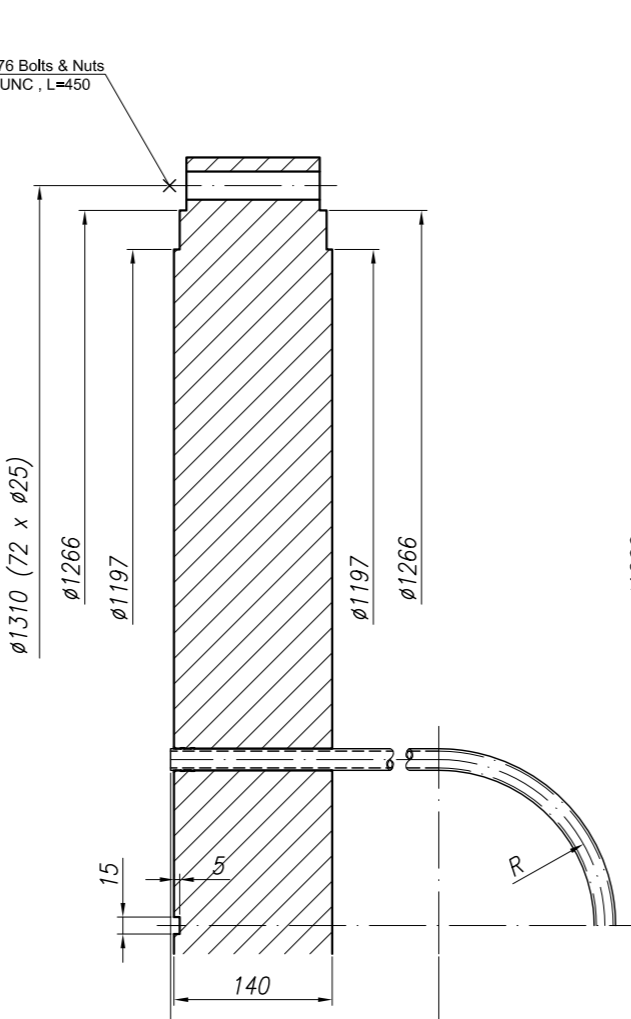

Tube Bundle Set (1:5)

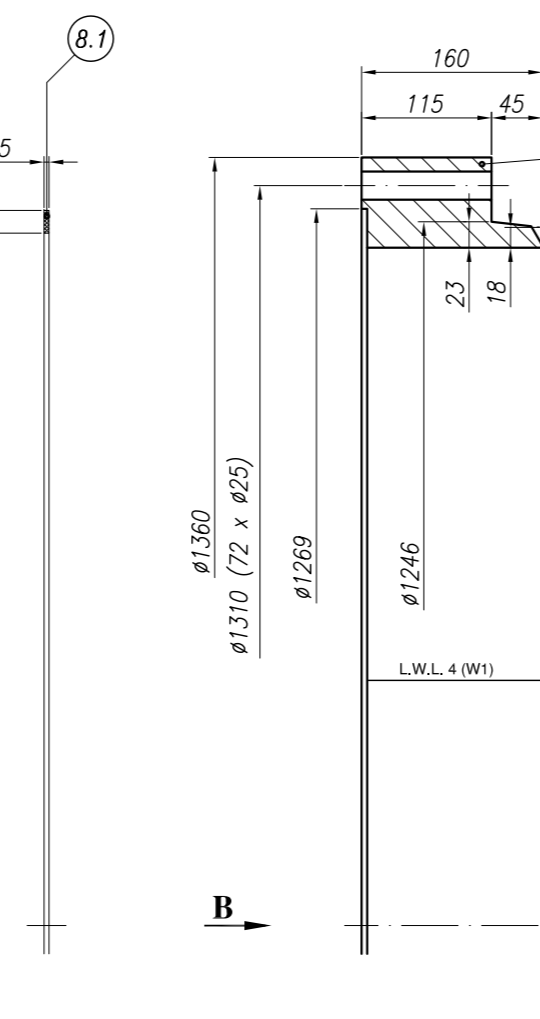

Gasket (1:5)

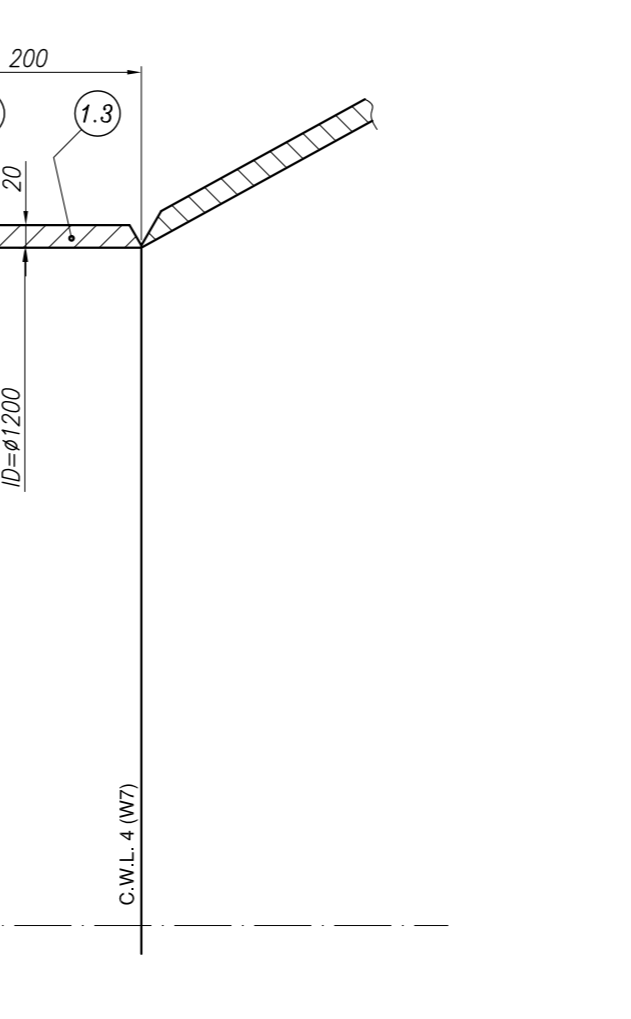

Shell Set (1:5)

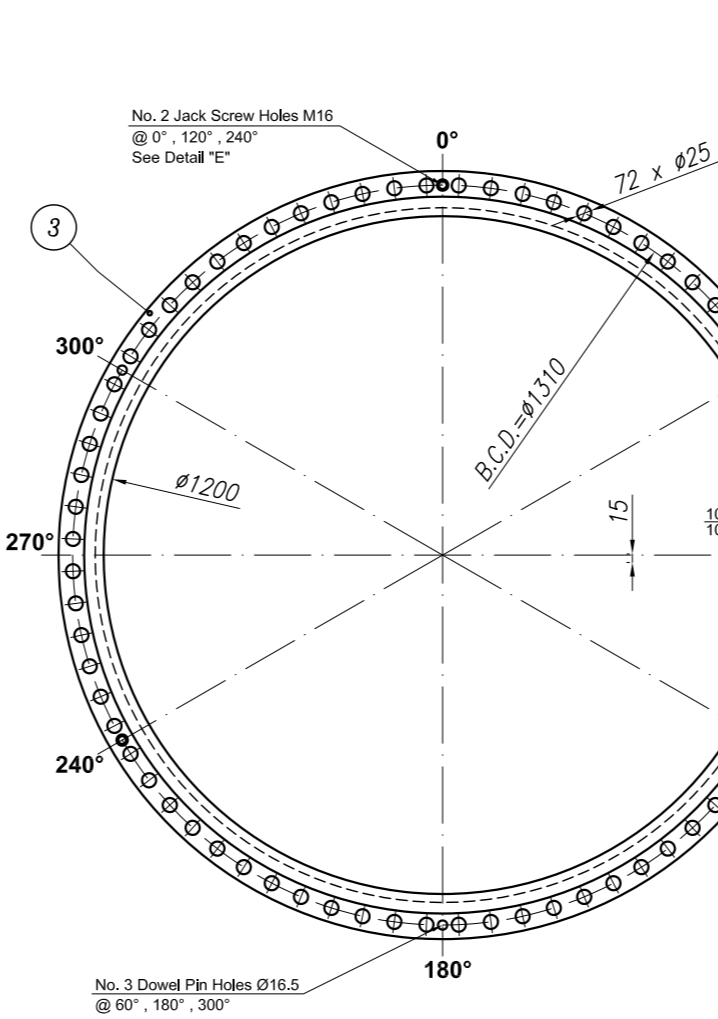

View "B" (1:10) Shell Body Flange

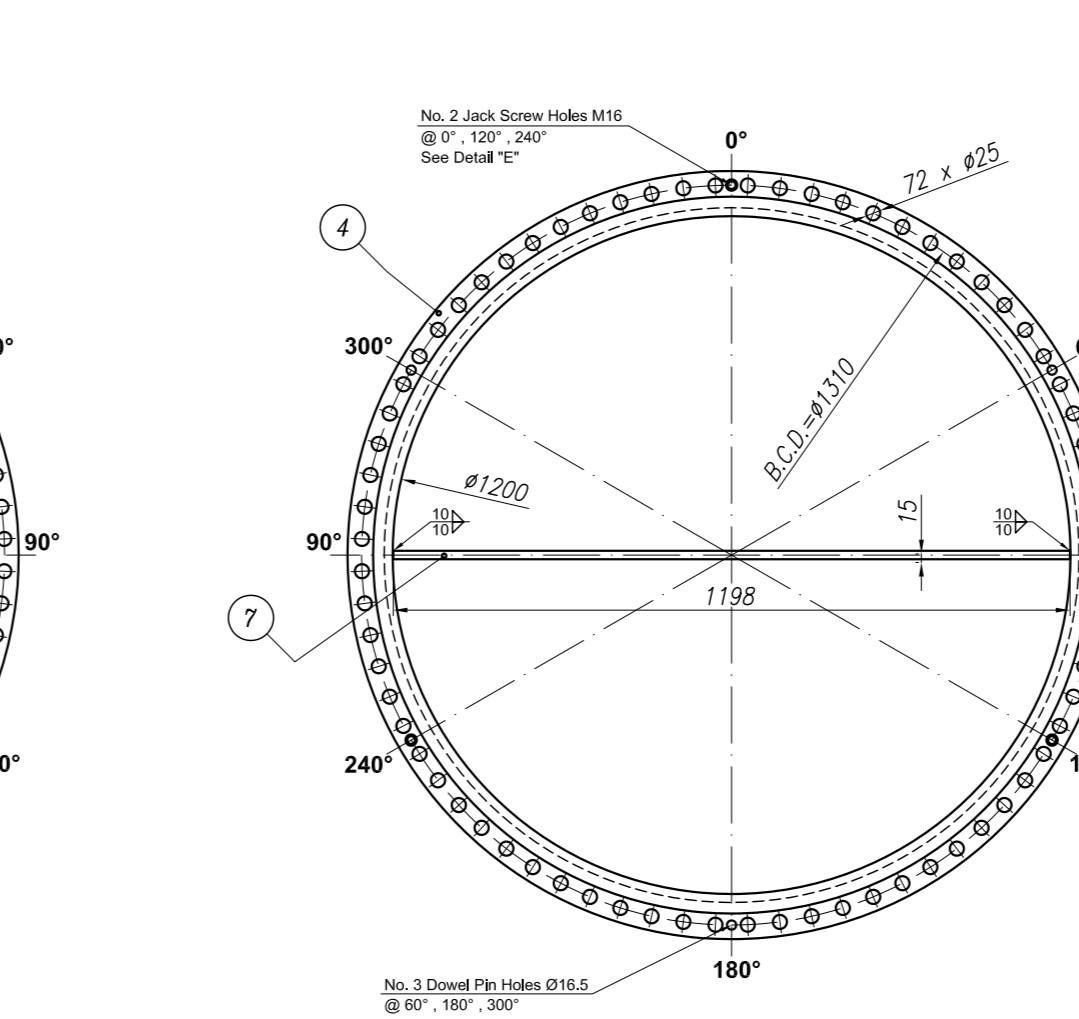

View "C" (1:10) Front Body Flange

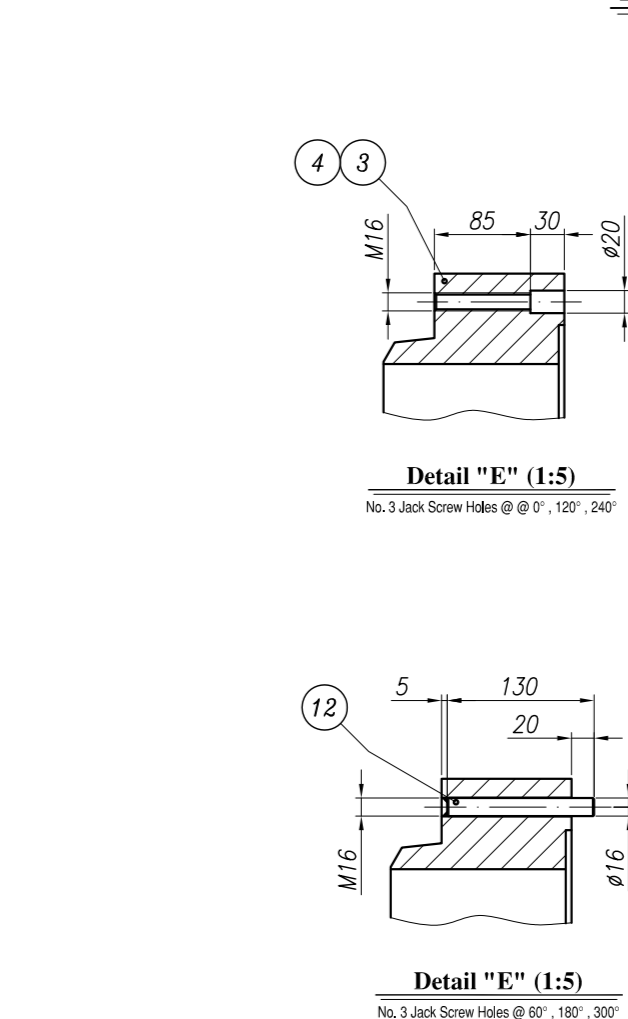

Detail "E" (1:5)

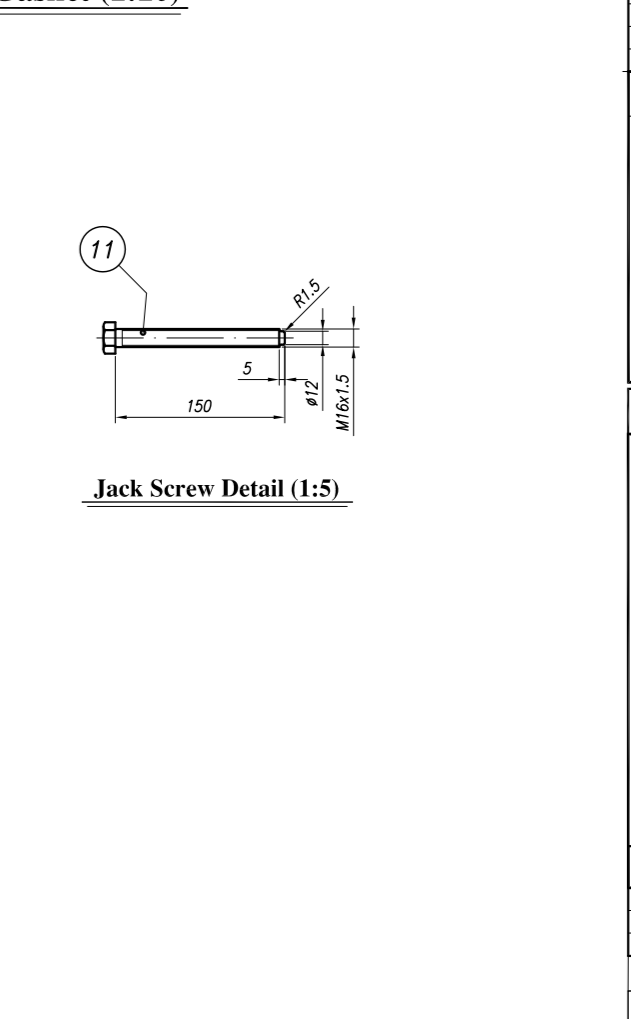

Jack Screw Detail (1:5)

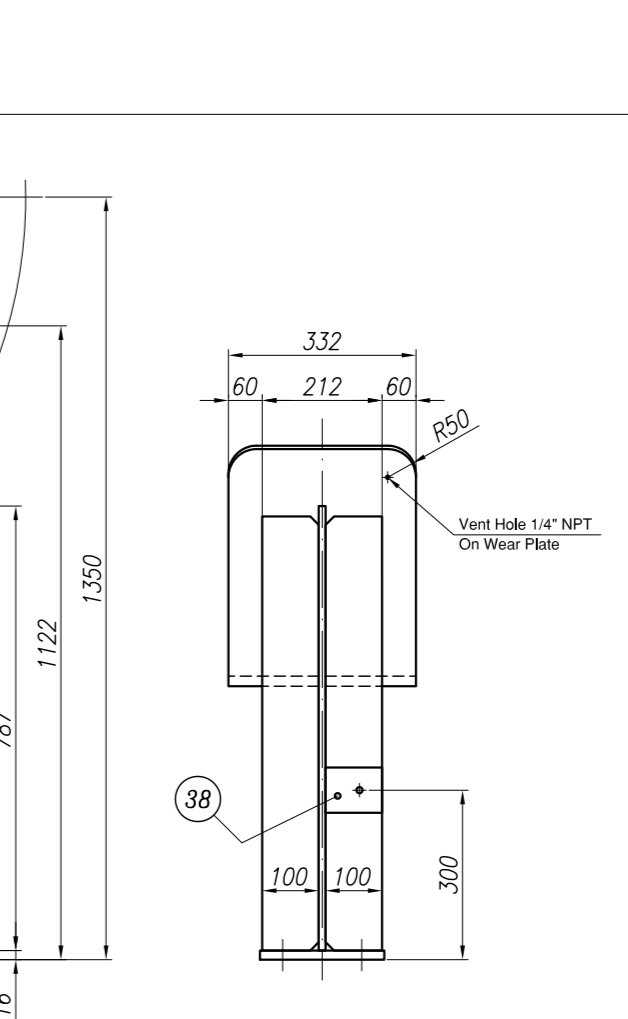

Web Plate Detail (1:20)

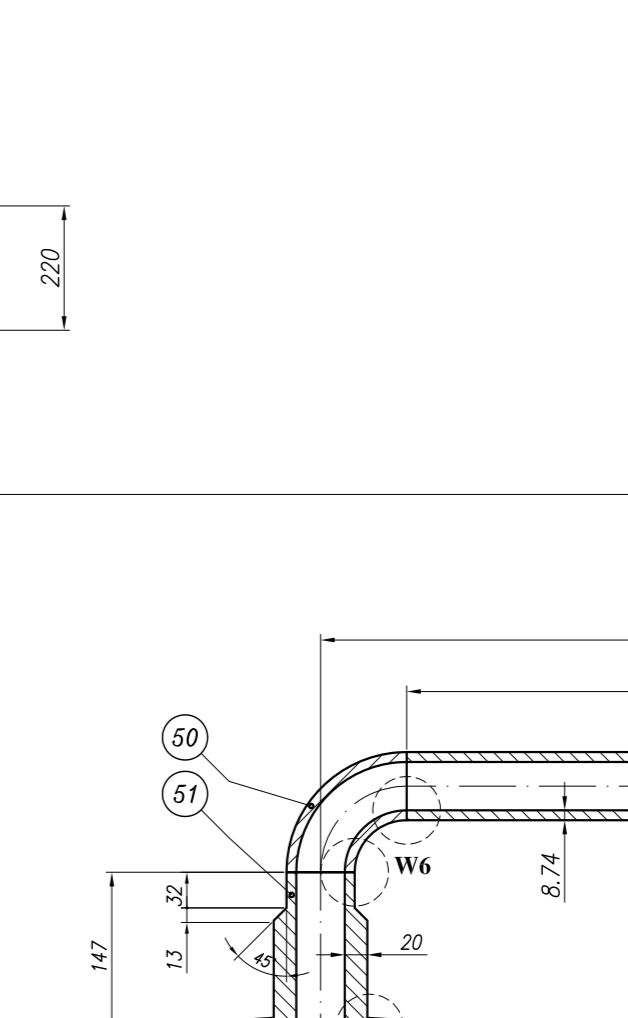

Web Plate Detail (1:20)



Earth Lug Detail (1:2.5)

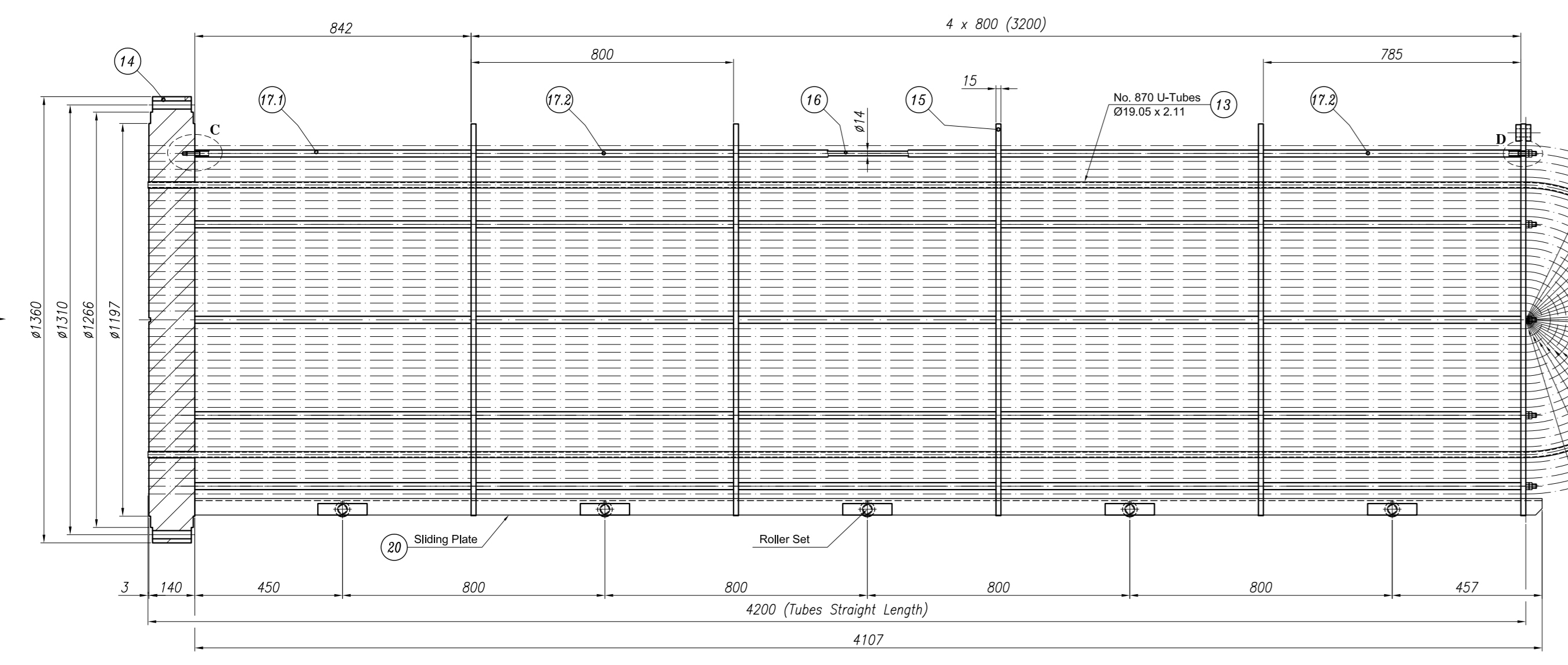

Tube Bundle View (1:10)

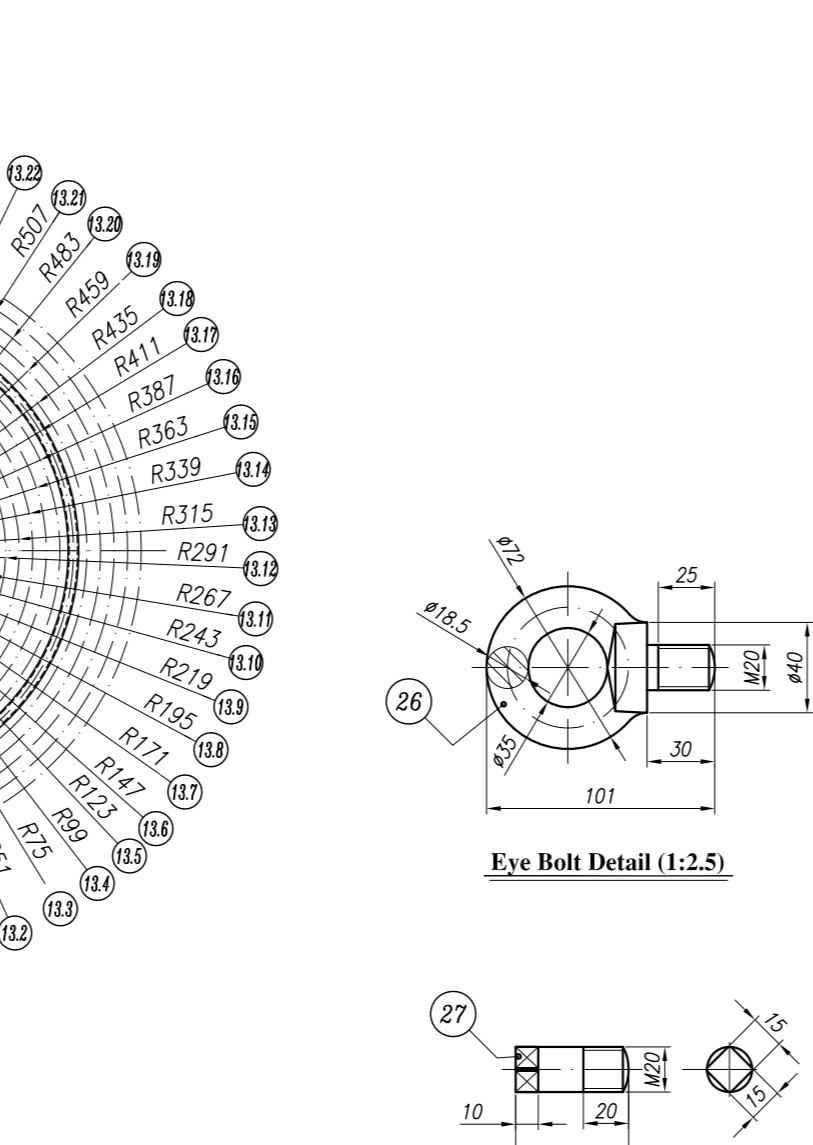

Support Saddle Detail (1:10)

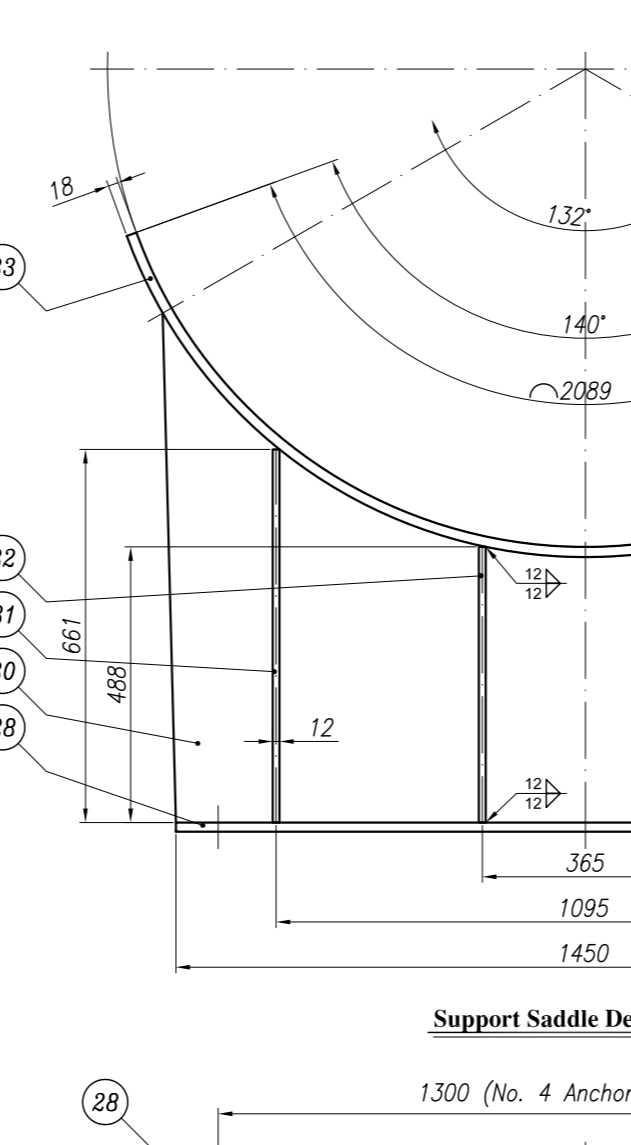

Fixed Saddle (1:10)

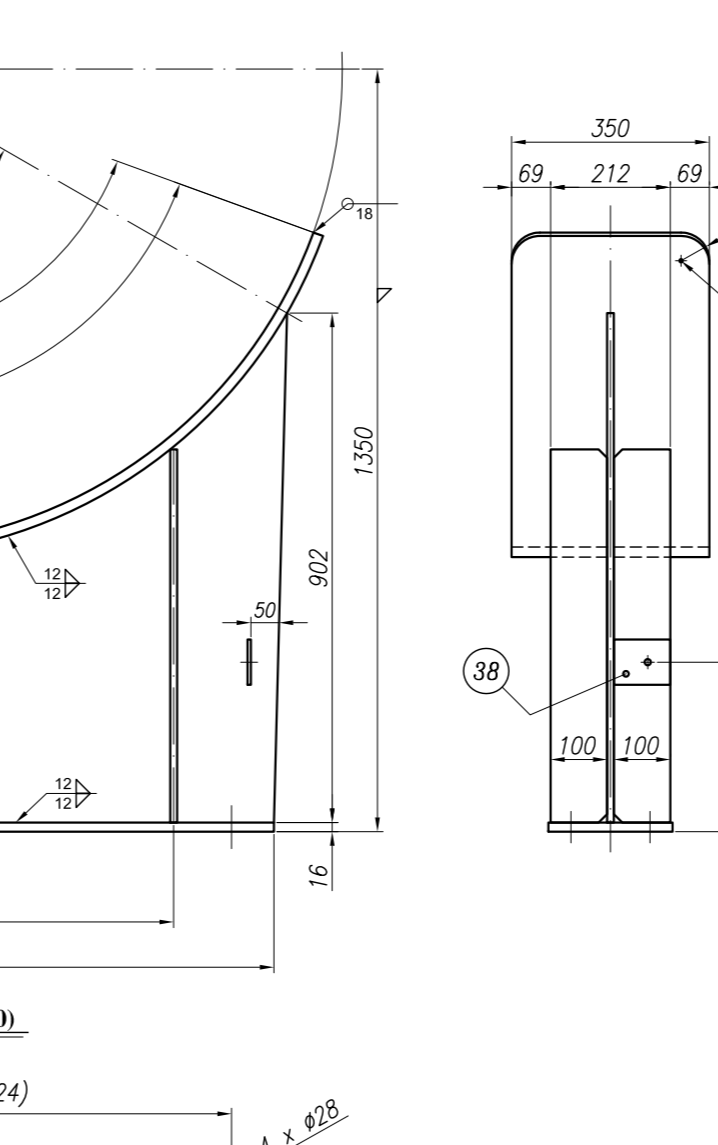

Sliding Saddle (1:10)

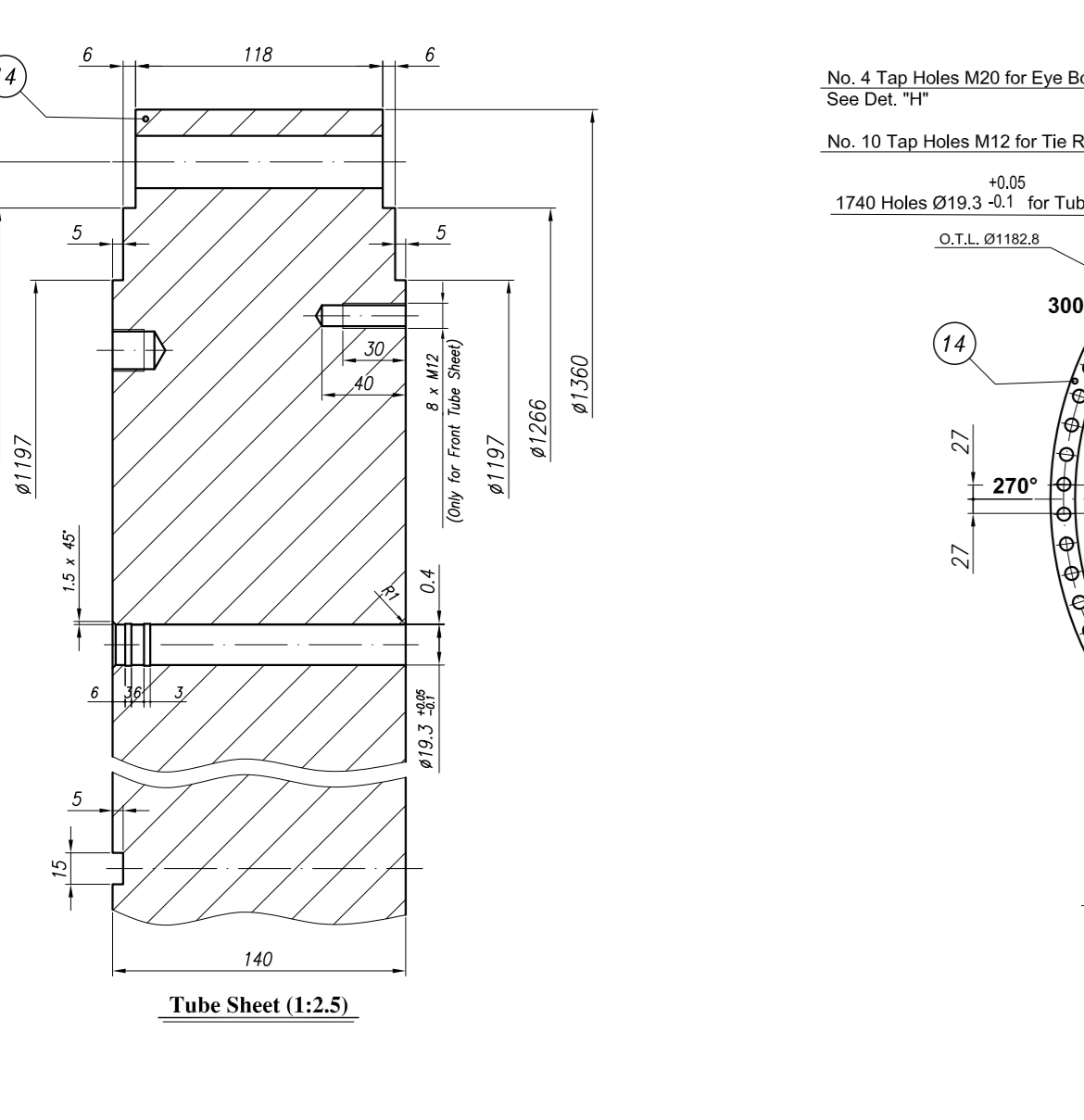

Tube Sheet (1:2.5)

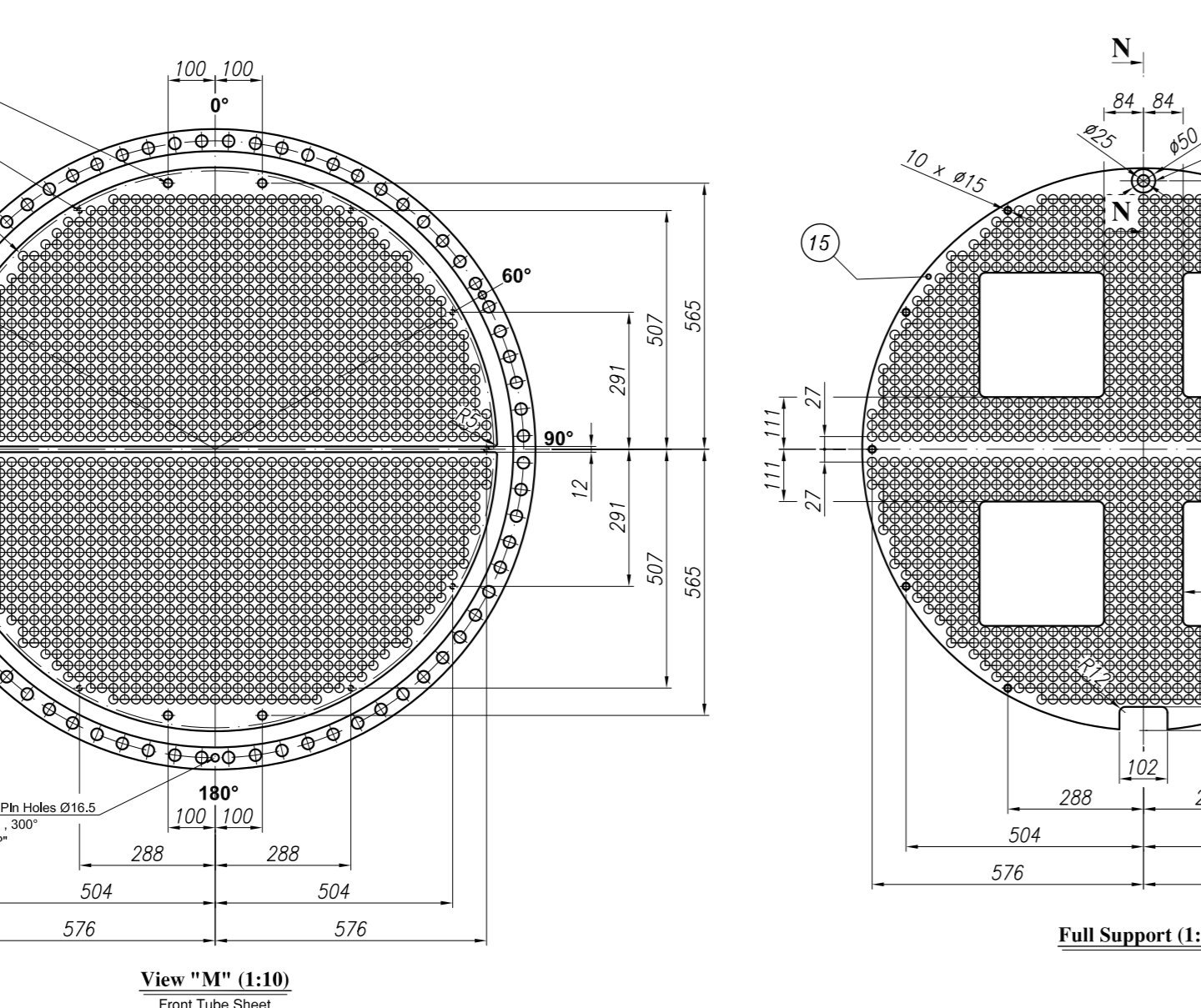

View "M" (1:10) Front Tube Sheet

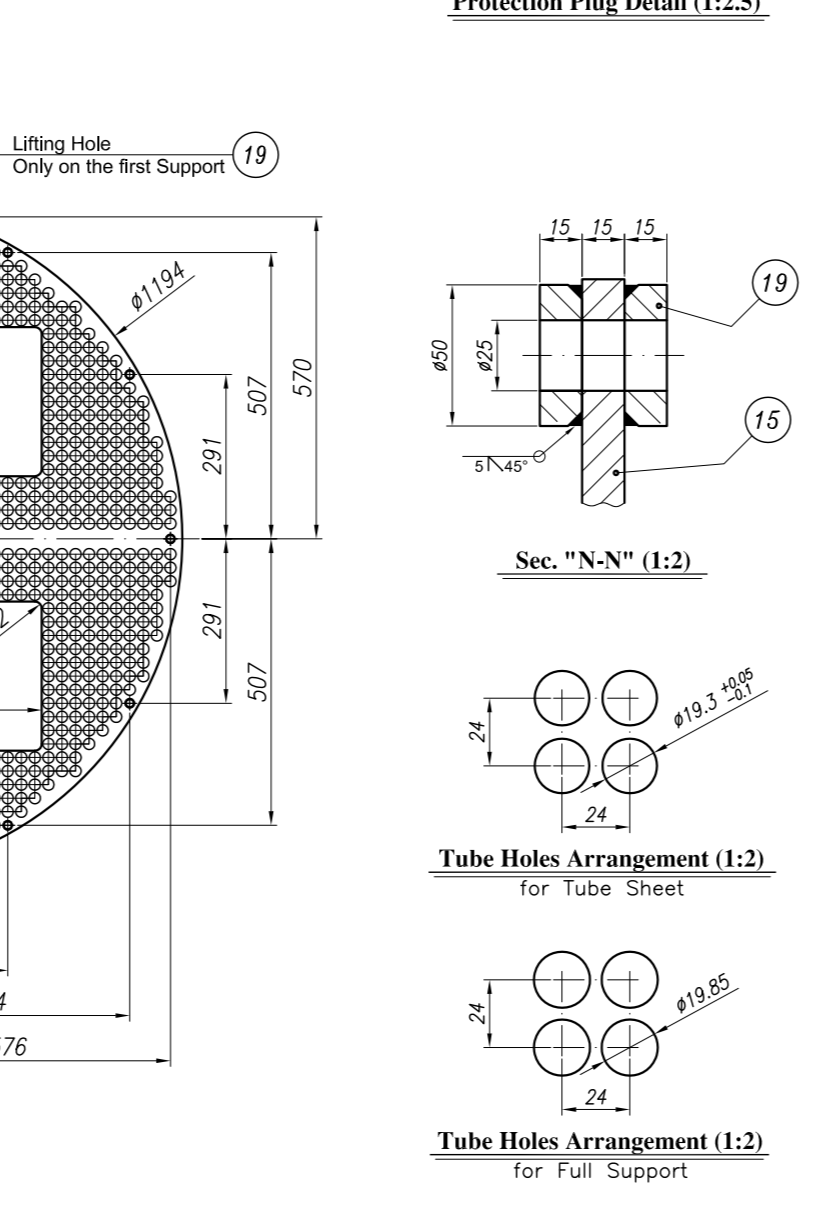

Full Support (1:10)

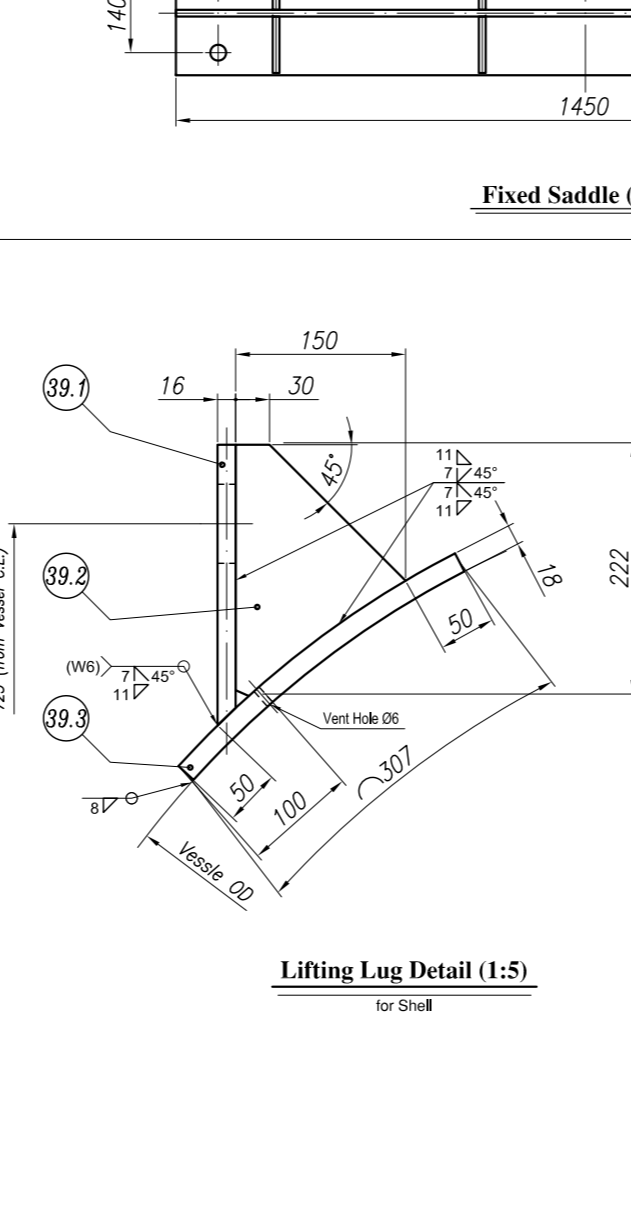

Eye Bolt Detail (1:2.5)

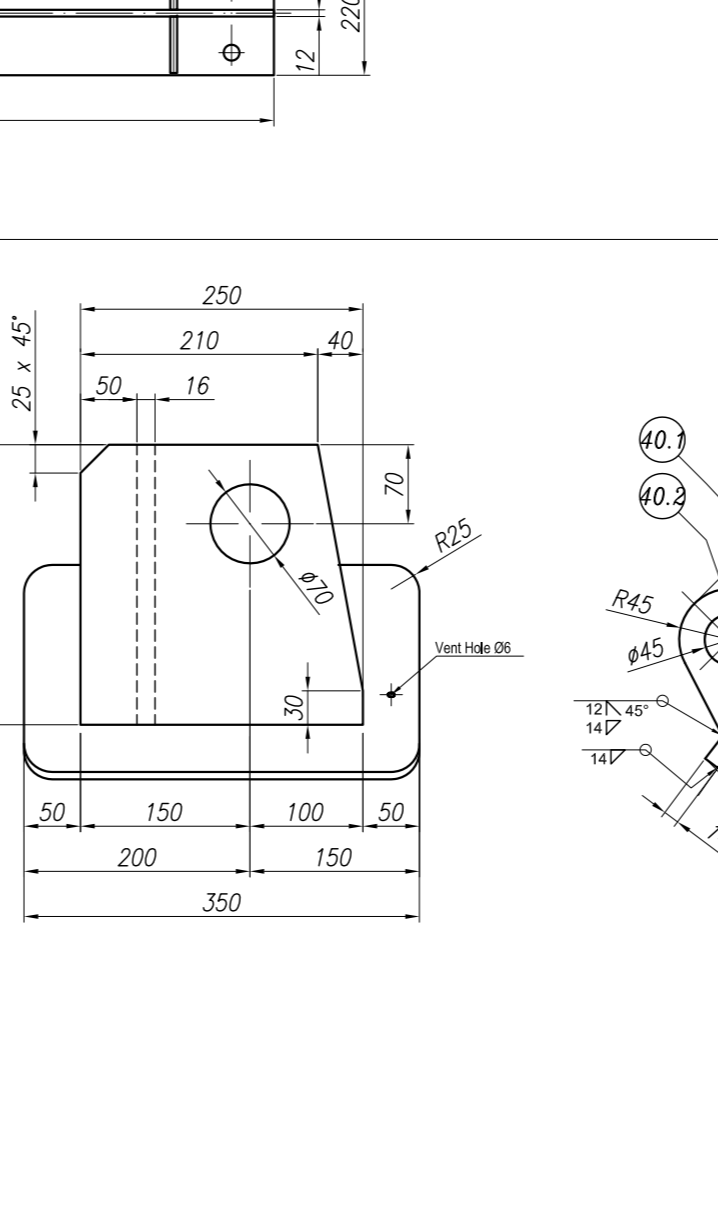

Protection Plug Detail (1:2.5)

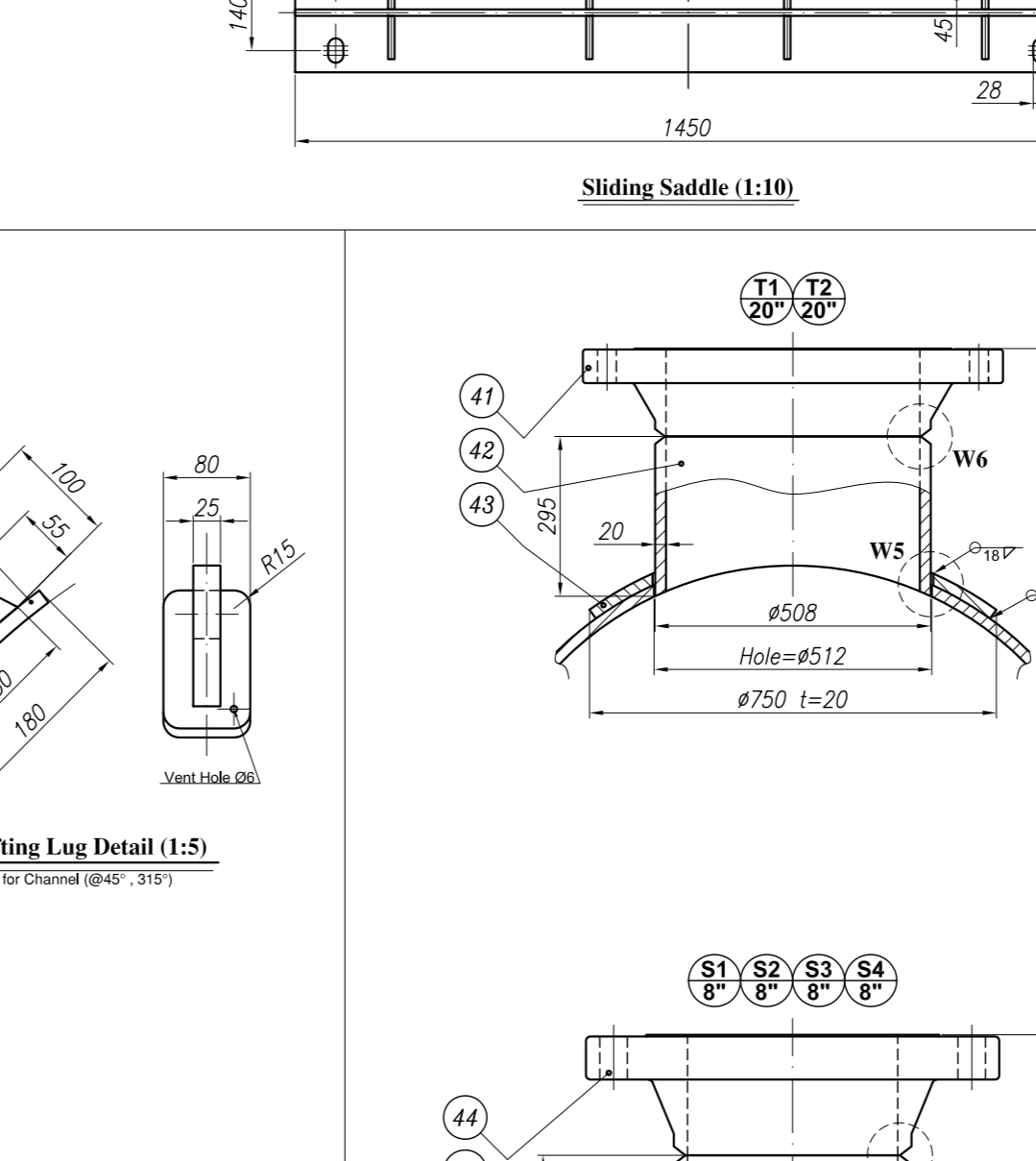

Sec. "N-N" (1:2)

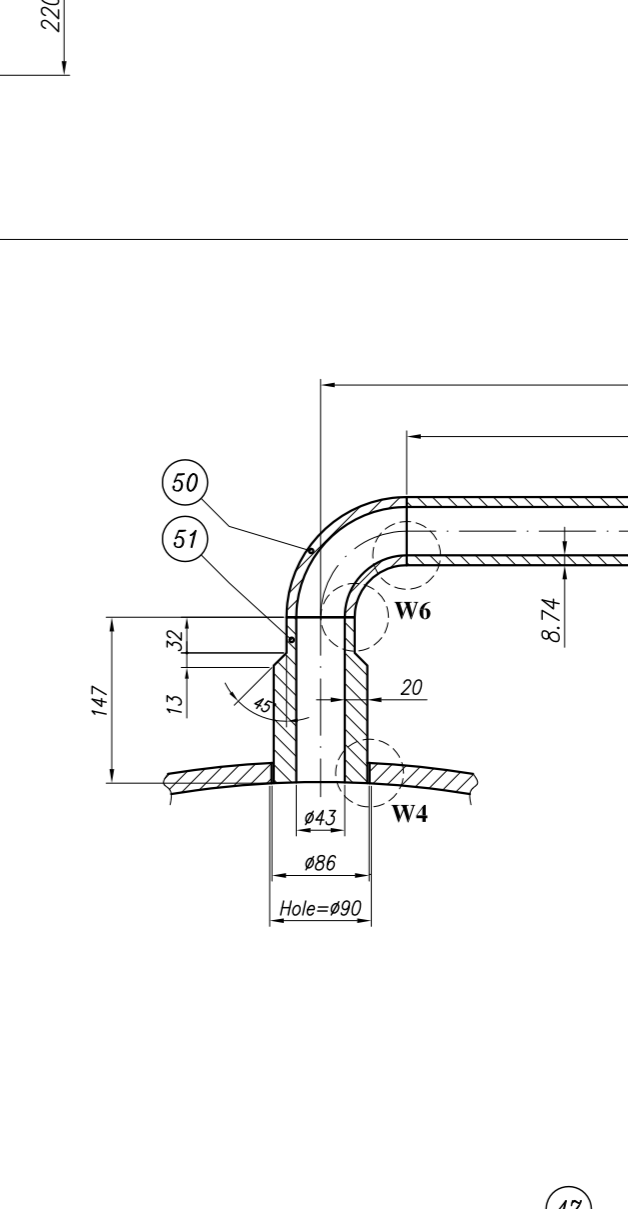

Tube Holes Arrangement (1:2) for Full Support

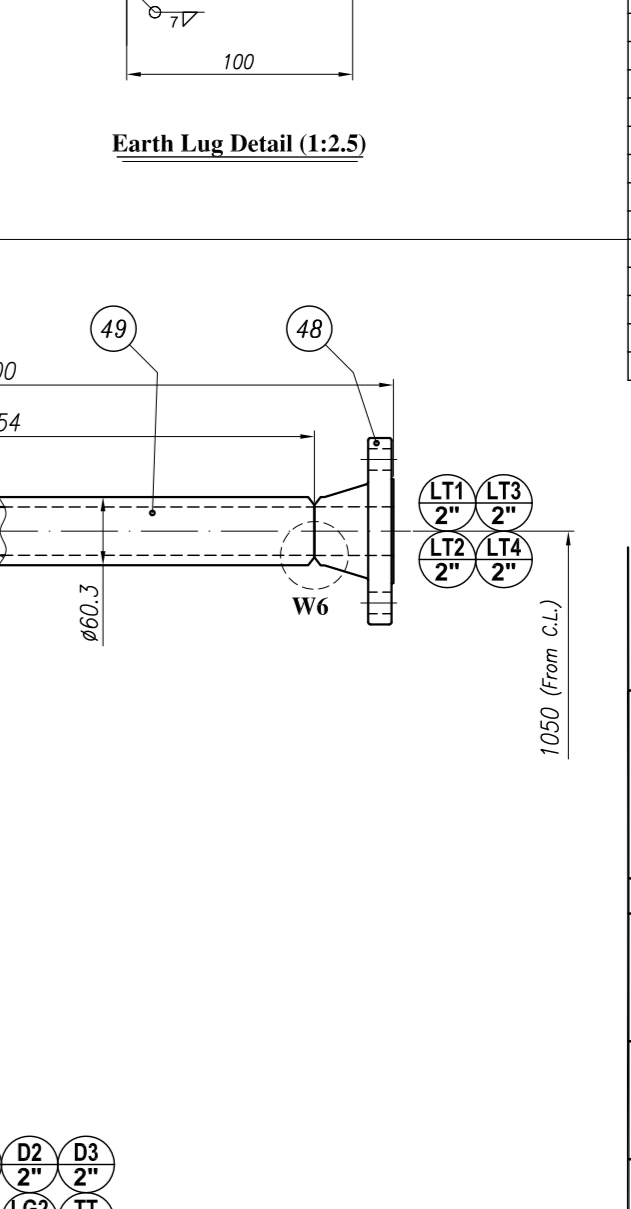

Lifting Lug Detail (1:5) for Shell (1:10)

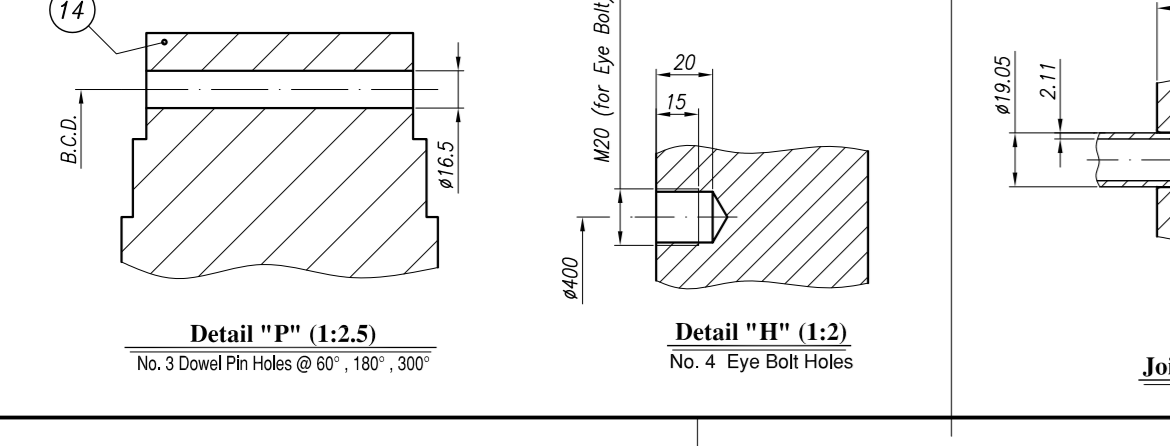

Detail "H" (1:2.5) No. 3 Dowel Pins @ 90°/180°/270°

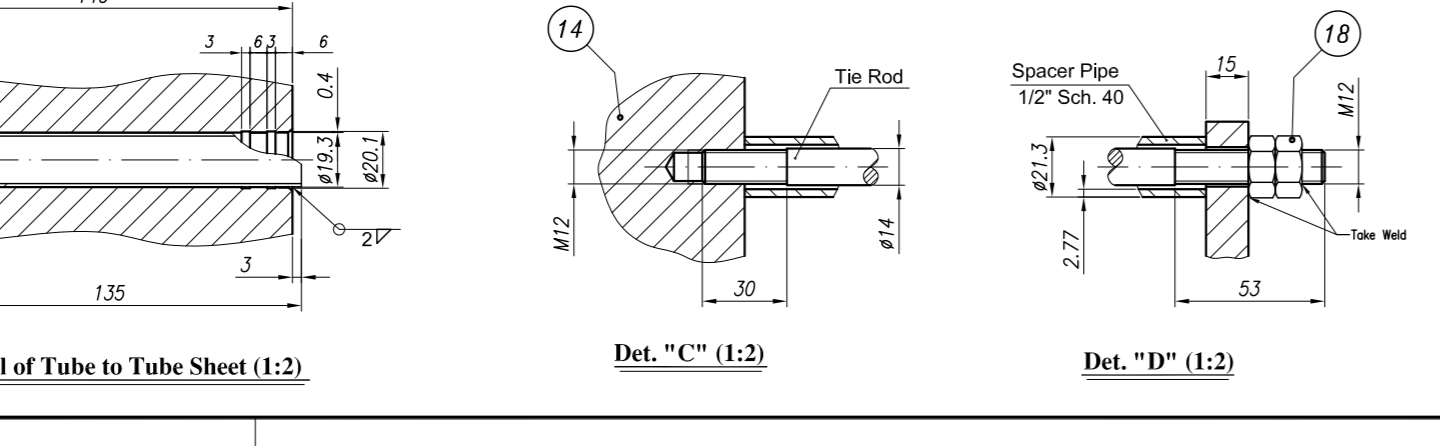

Detail "I" (1:2) No. 4 Eye Bolt Holes

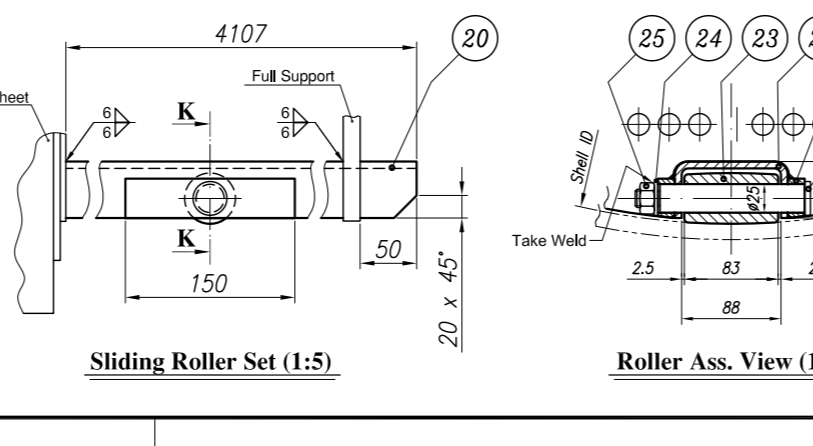

Joint Detail of Tube to Tube Sheet (1:2)

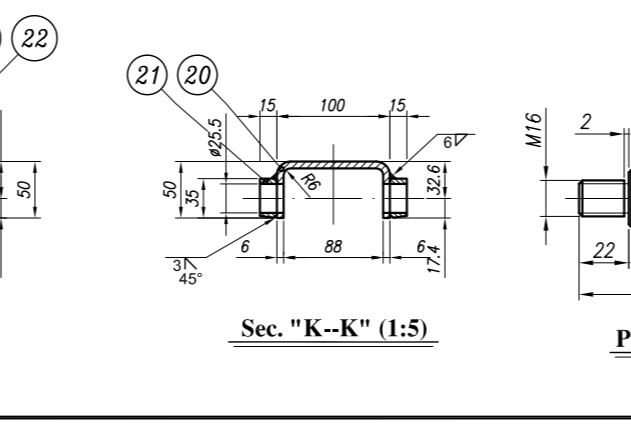

Det. "C" (1:2)

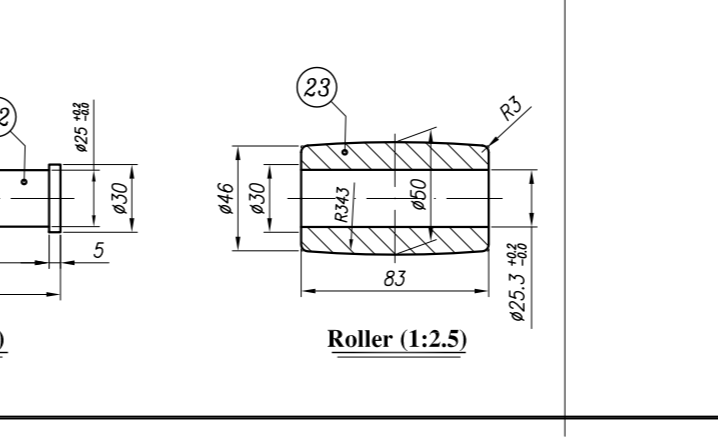

Det. "D" (1:2)

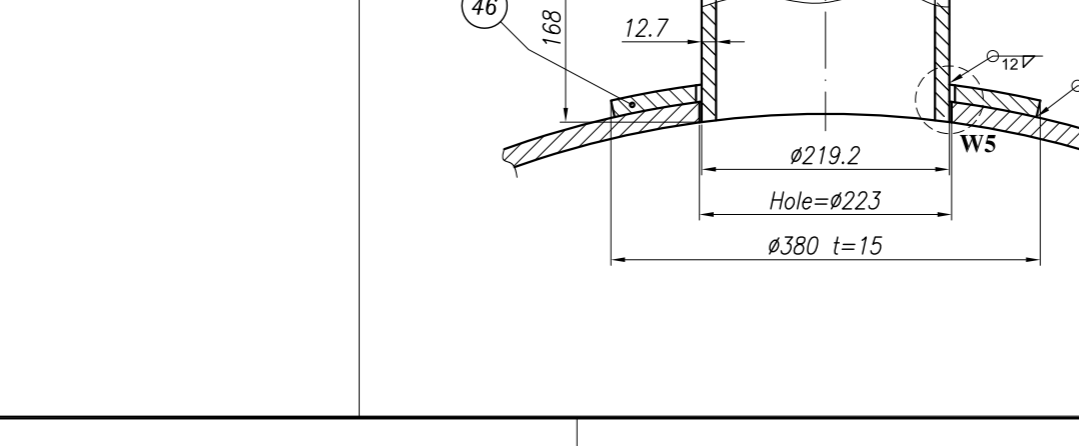

Sliding Roller Set (1:5)

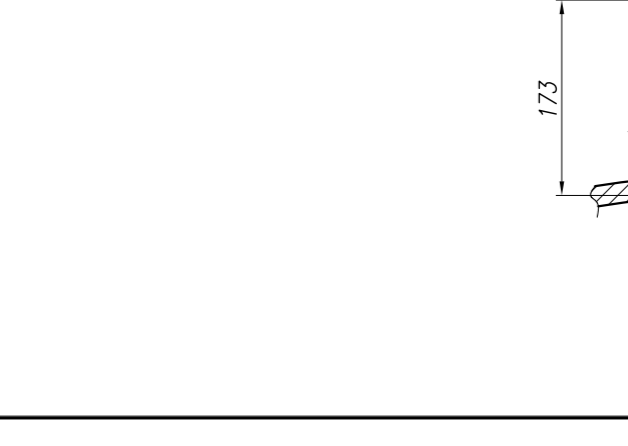

Roller Ass. View (1:5)

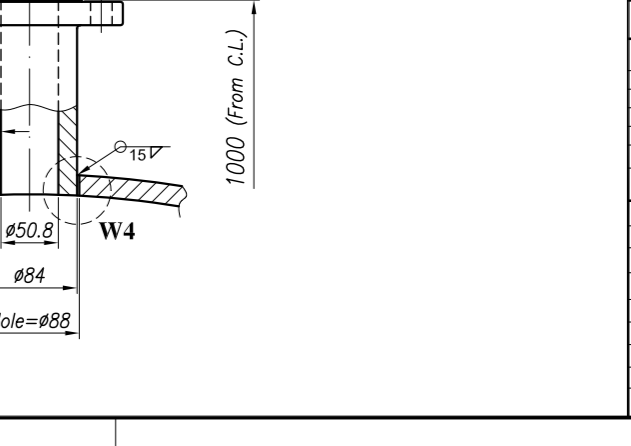

Sec. "K-K" (1:5)

LOADING DATA AT BASE									
OPERATING WEIGHT (NO)	137	137	137	137					
SEMI-EMPTY WEIGHT (NO)	137	137	137	137					
EMPTY WEIGHT (NO)	137	137	137	137					
OPERATING WEIGHT (NO)	137	137	137	137					
SEMI-EMPTY WEIGHT (NO)	137	137	137	137					
EMPTY WEIGHT (NO)	137	137	137	137					

WEIGHTS									
OPERATING WEIGHT (NO)	137	137	137	137					
SEMI-EMPTY WEIGHT (NO)	137	137	137	137					
EMPTY WEIGHT (NO)	137	137	137	137					

PARTS LIST									
NO.	PART NAME	MATERIAL	QTY	REMARK					
1.1	Shell (Shell)	SA 516 Gr. 70N	1	1					
1.2	Front Head (Plate)	SA 516 Gr. 70N	1	1					
1.3	Shell (Upper)	SA 516 Gr. 70N	1	1					
1.4	Body Flange	SA 516 Gr. 70N	1	1					
1.5	Front Head (Flange)	SA 516 Gr. 70N	1	1					
1.6	Front Head (Plate)	SA 516 Gr. 70N	1	1					
1.7	Flange (Front)	SA 516 Gr. 70N	1	1					
1.8	Gasket (Front)	Jacked Metal (DIN 9139)	1	1					
1.9	Gasket (Shell)	Jacked Metal (DIN 9139)	1	1					
1.10	Lifting Lug	SA 516 Gr. 70N	4	1					
1.11	Lifting Lug	SA 516 Gr. 70N	4	1					
1.12	Roller	SA 516 Gr. 70N	4	1					
1.13	Roller	SA 516 Gr. 70N	4	1					
1.14	Roller	SA 516 Gr. 70N	4	1					
1.15	Roller	SA 516 Gr. 70N	4	1					
1.16	Roller	SA 516 Gr. 70N	4	1					
1.17	Roller	SA 516 Gr. 70N	4	1					
1.18	Roller	SA 516 Gr. 70N	4	1					
1.19	Roller	SA 516 Gr. 70N	4	1					
1.20	Roller	SA 516 Gr. 70N	4	1					
1.21	Roller	SA 516 Gr. 70N	4	1					
1.22	Roller	SA 516 Gr. 70N	4	1					
1.23	Roller	SA 516 Gr. 70N	4	1					
1.24	Roller	SA 516 Gr. 70N	4	1					
1.25	Roller	SA 516 Gr. 70N	4	1					
1.26	Roller	SA 516 Gr. 70N	4	1					
1.27	Roller	SA 516 Gr. 70N	4	1					
1.28	Roller	SA 516 Gr. 70N	4	1					
1.29	Roller	SA 516 Gr. 70N	4	1					
1.30	Roller	SA 516 Gr. 70N	4	1					
1.31	Roller	SA 516 Gr. 70N	4	1					
1.32	Roller	SA 516 Gr. 70N	4	1					
1.33	Roller	SA 516 Gr. 70N	4	1					
1.34	Roller	SA 516 Gr. 70N	4	1					
1.35	Roller	SA 516 Gr. 70N	4	1					
1.36	Roller	SA 516 Gr. 70N	4	1					
1.37	Roller	SA 516 Gr. 70N	4	1					
1.38	Roller	SA 516 Gr. 70N	4	1					
1.39	Roller	SA 516 Gr. 70N	4	1					
1.40	Roller	SA 516 Gr. 70N	4	1					
1.41	Roller	SA 516 Gr. 70N	4	1					
1.42	Roller	SA 516 Gr. 70N	4	1					
1.43	Roller	SA 516 Gr. 70N	4	1					
1.44	Roller	SA 516 Gr. 70N	4	1					
1.45	Roller	SA 516 Gr. 70N	4	1					
1.46	Roller	SA 516 Gr. 70N	4	1					
1.47	Roller	SA 516 Gr. 70N	4	1					
1.48	Roller	SA 516 Gr. 70N	4	1					
1.49	Roller	SA 516 Gr. 70N	4	1					
1.50	Roller	SA 516 Gr. 70N	4	1					

CLIENT:

CONTRACTOR:

PROJECT TITLE: **DEHASHT PETROCHEMICAL INDUSTRY COMPANY**
DEHASHT HIGH DENSITY POLYETHYLENE PROJECT

DRAWING TITLE: **EVAPORATOR DRAWING (E-PK1601)**

DOCUMENT NO: **DPIC812-000-VD-1002-ME-DWG-0087**

PROJ. CODE: **000 VD 1002 4150 ME DWG 0087 03 OF 3**

REVISIONS:

NO.	DATE	DESCRIPTION	BY	CHKD	APP'D
1					
2					
3					
4					
5					
6					
7					
8					
9					
10					
11					
12					
13					
14					
15					
16					
17					
18					
19					
20					
21					
22					
23					
24					
25					
26					
27					
28					
29					
30					
31					
32					
33					
34					
35					
36					
37					
38					