	DEHDASHT PETROCHEMICAL INDUSTRY COMPANY DEHDASHT HIGH DENSITY POLYETHYLENE PROJECT	
	DOCUMENT TITLE: K.O. Drum Data Sheet	POI: IFA
Contract No.: DPIC/98-12	DOCUMENT NUMBER: DPIC9812-000-VD-1002-ME-DS-0082	Rev. No.: D1

DOCUMENT TITLE:

**K.O. Drum Data Sheet
(D-PK6101-3)**

PURCHASER'S COMMENT/APPROVAL STATUS				Purchaser: NARGAN
1	AP: Approved (Released for Manufacturing)	Requisition No.: DPIC98-12-001-000-ME-MR-4150-0001-D1		
<input checked="" type="checkbox"/>	AN: Approved With Minor Comments (Fabrication may Proceed)			
3	NF: Approved With Comments (Fabrication not Proceed)	Item No. (Tag No.): PK-6101		
4	RJ: Rejected			
5	NR: Not be Returned	Vendor Doc. No.: DPIC9812-000-VD-1002-ME-DS-0082-D1		
Date: 15.01.2022				

D1	20.Dec..21	R.GOUDARZI	DR.A.NEJATI	DR.A.NEJATI
D0	19.Nov..21	A.VOSOUGH	DR.A.NEJATI	DR.A.NEJATI
REV	DATE ISSUE	PREPARED	CHECKED	APPROVED



This document is the property of PEDEC. Any unauthorized attempt to reproduce it, in any form, is strictly prohibited.



DEHDASHT PETROCHEMICAL INDUSTRY COMPANY

DEHDASHT HIGH DENSITY POLYETHYLENE PROJECT



DOCUMENT TITLE: K.O. Drum Data Sheet

POI: IFA

Contract No.: DPIC/98-12



DOCUMENT NUMBER: DPIC9812-000-VD-1002-ME-DS-0082

Rev. No.: D1

Page	Rev-D0	Rev-D1	Rev-D2	Rev-D3	Rev-D4
1	x	x			
2	x	x			
3	x	x			
4	x	x			
5					
6					
7					
8					
9					
10					
11					
12					
13					
14					
15					
16					
17					
18					
19					
20					
21					
22					
23					
24					
25					
26					
27					
28					
29					
30					
31					
32					
33					
34					
35					

Page	Rev-D0	Rev-D1	Rev-D2	Rev-D3	Rev-D4
36					
37					
38					
39					
40					
41					
42					
43					
44					
45					
46					
47					
48					
49					
50					
51					
52					
53					
54					
55					
56					
57					
58					
59					
60					
61					
62					
63					
64					
65					
66					
67					
68					
69					
70					

This document is the property of PEDEC. Any unauthorized attempt to reproduce it, in any form, is strictly prohibited.

		DEHDASHT PETROCHEMICAL INDUSTRY COMPANY DEHDASHT HIGH DENSITY POLYETHYLENE PROJECT							
		DOCUMENT TITLE: K.O. Drum Data Sheet				POI: IFA			
Contract No: DPIC/00-12 ID to be reported.		DOCUMENT NUMBER: DPIC9812-000-VD-1002-ME-DS-0082				Rev. No.: D1			
VESSEL									
1	SERVICE	K.O. DRUM				ITEM NO.	D-PK-6101-3		
2	TYPE	VERTICAL				QUANTITY :	1		
3	SHELL OD :	1800	TL.TL.:	2800	mm	CAPACITY	SHELL : 7.78 m ³		
4	JACKET ID :	-	TL.TL.:	-	mm		JACKET: - m ³		
5	WEIGHT:	EMPTY:	OPERATING:		kg	INSTALLATION:	OUTDOOR		
DESIGN & TEST DATA				MATERIALS					
6		SHELL		JACKET		SHELL	JACKET		
8	CODE & STD	ASME SECT.VIII (NO STAMP)				SHELL/PADS	SA-516 GR70N		
9	FLUID	PROPYLENE				HEAD	SA-516 GR70N		
10	TEMPERATURE	DESIGN	-45/135	°C	-	°C	GIRTH FLG/CV	-	
11		OPERATING	-24.0	°C	-	°C	NOZZLE NECKS	SA-333 Gr6	
12	PRESSURE	DESIGN	23.0	BarG	-	BarG	NOZZLE FLANGE	SA-350 LF2	
13		OPERATING	1.6	BarG	-	BarG	INTERNALS	S.S. 304	
14		VACUUM	1.013	BarA	-	BarG	INT PIPES	S.S. 304	
15	DENSITY @PT	5.8	kg/m ³	-	kg/m ³	BOLTS / NUTS	NZL FLG	-	
16	VISCOSITY @PT	0.007	cP	-	cP		GIRTH FLG	-	
17	CORROSION ALLOW.	3	mm	-	mm		INT	-	
18							EXT	A193Gr.B7/A194Gr.2H	
19	TEST	HYDRO	34.5	BarG	-	BarG	NZL FLG	SPIRAL WOUND	
20		PNUEM LEAK	-	BarG	-	BarG	GIRTH FLG	-	
21		VACUUM	0.02	BarG			INT	-	
22	POST WELD HEAT TREAT	AS PER CODE				SADDEL/PADS	SA-516 GR70	-	
23	RADIOGRAPHIC EXAM. (CYL/HD)	FULL/FULL				CLIPS/PADS	-	-	
24	JOINT EFF (CYL/HD)					ANCHOR BOLT	A36	-	
25	WELDER'S QUALIF					LIFTING LUG/PAD	SA-516 GR70N	-	
26	SEISMIC COEF	AS PER SPEC.				BLIND FLANGE	SA-350 LF2	-	
27	WIND LOAD	AS PER SPEC.							
28	TYPE OF HEAD	ELLIP. 2:1							
29	INSULATION (THK,AREA)	COLD	100	mm	REMARKS:				
30	SURFACE PREP EXT/INT	- / -							
31	FIRE PROOFING	NO							
32		YES							
33		LIFT LUG, NAME PL							
34		RTH LUG							
35									
36									
37									
38	TOLERANCE								
NOZZELS & OPENINGS (per one shell)									
40	MARK	12"	IO.	6"	FLANGE	WALL THK	SERVICE	ELEV.	NOTES
41					RATING	TYPE	FACE		
42	A1	10"	1	6"	ASME 300#				PRORYLENE INLET
43	A2	8"	1		ASME 300#				START-UP BYPASS INLET
44	B	12"	1		ASME 300#				PRORYLENE OUTLET
45	D	2"	1		ASME 300#				DRAIN
46	LG1,2	2"	2		ASME 300#	RF			LEVEL GAUGE
47	LT1,2	2"	2		ASME 300#	RF			LEVEL TRANSMITTER
48	M1	20"	1		ASME 300#	RF			MANHOLE
49	M2	6"	1		ASME 300#	RF			INSCPTION HOLE
51	SV	2"	1		ASME 300#	RF			SAFETY VALVE
52	TI	1/12"	1		ASME 300#	RF			TEMPERATURE GAUGE
53	V	2"	1		ASME 300#	RF			VENT
54									
55									
56									
57									
57									
T= TOP HEAD		S= SHELL				B= BOTTOM HEAD			

Based on PID this instrument is installed on stand pipe and there is not any LG connection on Vessel

Based on PID. RTH LUG

As per PID LT1 is located on drain pipe so it is not on vessel.

Level trans could not be magnetic type, Dp or Displacer is applicable, so please modify connections (DP:3", Displacer 2" as per project specification) accordingly

To be noted it will be finalized after PSV calculation.

This document is the property of PEDEC. Any unauthorized attempt to reproduce it, in any form is prohibited.



DEHDASHT PETROCHEMICAL INDUSTRY COMPANY
DEHDASHT HIGH DENSITY POLYETHYLENE PROJECT



DOCUMENT TITLE: K.O. Drum Data Sheet

POI: IFA

Contract No.: DPIC/98-12

DOCUMENT NUMBER: DPIC9812-000-VD-1002-ME-DS-0082

Rev. No.: D1

SKETCH

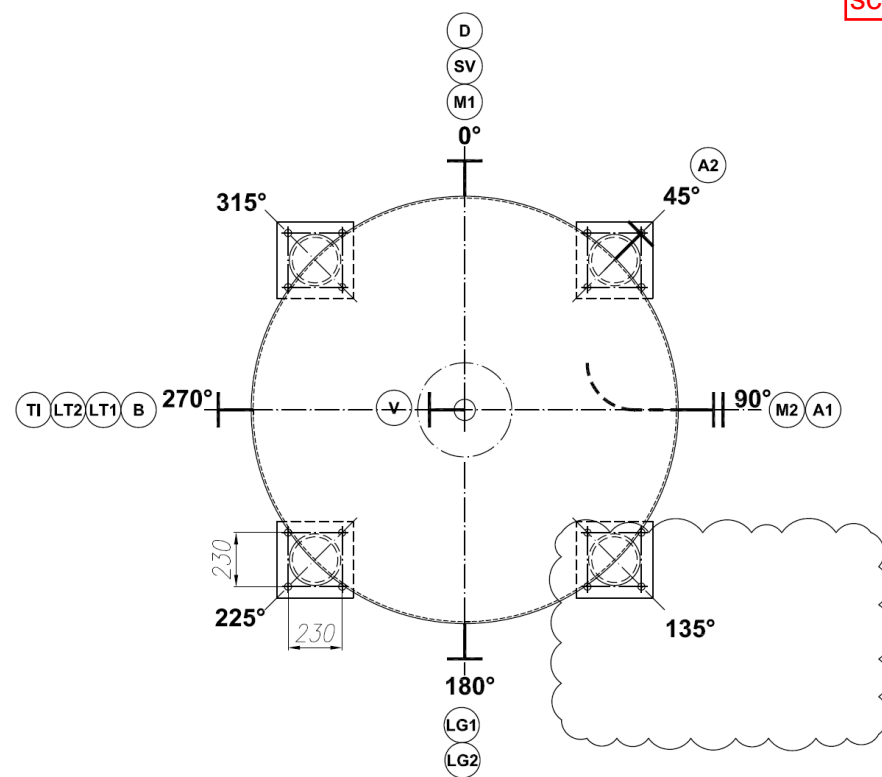
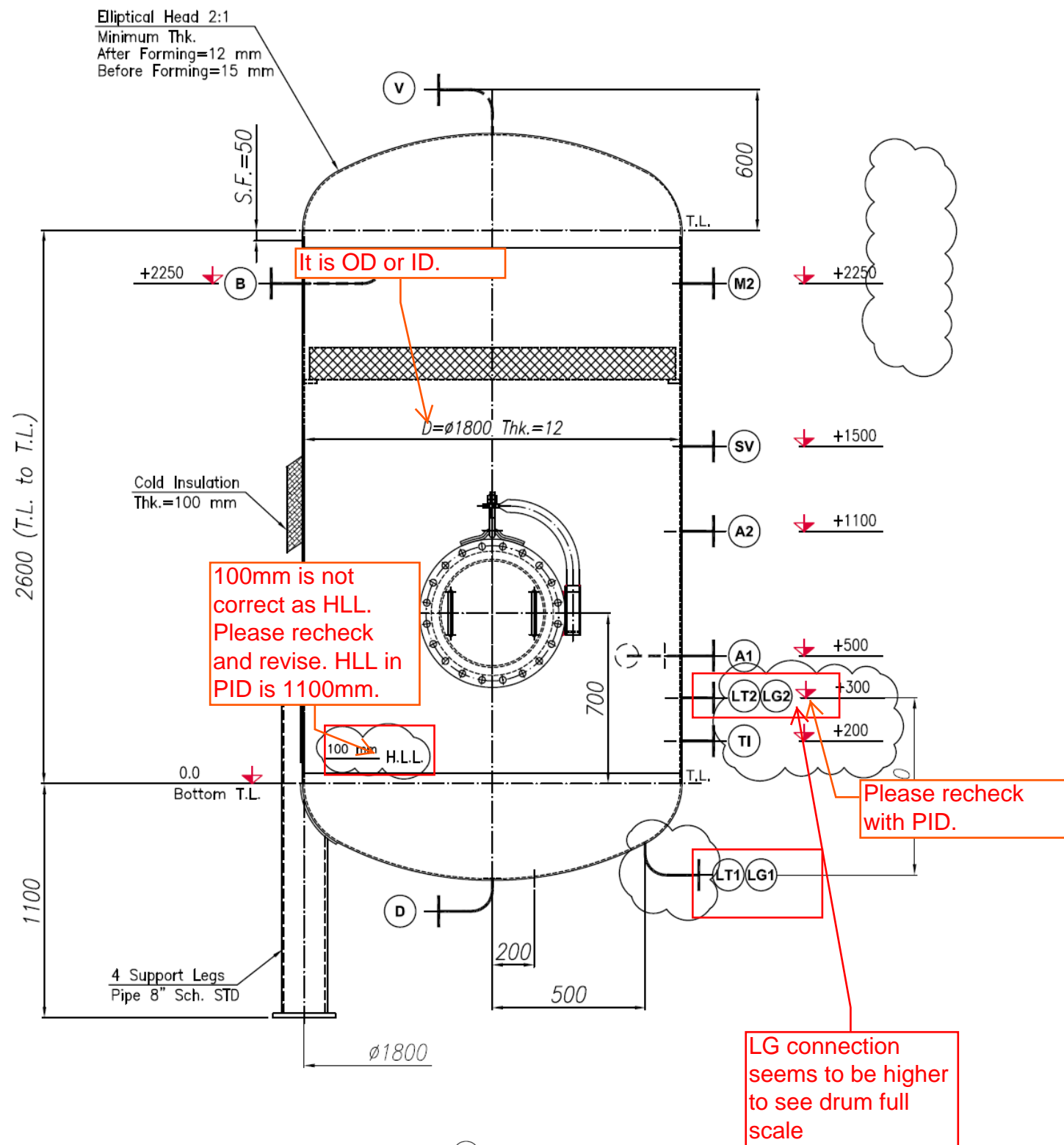

Nozzle Orientation Plan
HOLD

This document is the property of PEDEC. Any unauthorized attempt to reproduce it, in any form, is strictly prohibited.