

	CONCEPTUAL, BASIC and DETAIL DESIGN ENGINEERING OF STYRENE PARK OFFSITE	
	Document Title: General Arrangement Drawing-Active Carbon Filter for Active Carbon Package	
Document No.: EI027-ENR-VD-ME-DWG-005	Rev. R0	Page 1 of 3

STYRENE PARK OFFSITE

Commented:

~~Please , to be implemented and followed technical recommendations As below Engineering Documents :~~

- PFD For STYREN (EI027-000-ED-PR-PFD-501-R3)
- P&ID For STYREN (EI027-000-ED-PR-PID-522-R4)
- Process Duty Specification For Activated Carbon Packag (EI027-000-ED-PR-SPC-500 , Rev.02)

Document Title

General Arrangement Drawing-Active Carbon Filter

FOR

Active Carbon Package

R0	2024/04/03	Issued For Approval	M.Teymouri	E.Malek	H.Keshmiri
Rev.	Issued Date	DESCRIPTION	PREPARED	CHECKED	APPROVED



CONCEPTUAL, BASIC and DETAIL DESIGN
ENGINEERING OF STYRENE PARK OFFSITE

Document Title: General Arrangement Drawing-Active
Carbon Filter for Active Carbon Package



Document No.: EI027-ENR-VD-ME-DWG-005

Rev. R0

Page 2 of 3

REVISION RECORD SHEET

Page	Revisions							Page	Revisions						
	R0	R1	R2	R3	R4	R5	R6		R0	R1	R2	R3	R4	R5	R6
1	x							41							
2	x							42							
3	x							43							
4								44							
5								45							
6								46							
7								47							
8								48							
9								49							
10								50							
11								51							
12								52							
13								53							
14								54							
15								55							
16								56							
17								57							
18								58							
19								59							
20								60							
21								61							
22								62							
23								63							
24								64							
25								65							
26								66							
27								67							
28								68							
29								69							
30								70							
31								71							
32								72							
33								73							
34								74							
35								75							
36								76							
37								77							
38								78							
39								79							
40								80							

DESIGN DATA			
APPLICABLE CODE	ASME, Sec.VIII, Div 1	DESIGN PRESSURE	-0.1~0.2 Bar(g)
WIND CODE	UBC	OPERATING PRESSURE	0.07 Bar(g)
WIND DESIGN DATA	SPEED:125 Km/hr EXPOSURE: C IMP. FACTOR: 1.15	VOLUME (Uncor./cor.)	21.16/21.3
SEISMIC CODE	ASCE/SEI 7-16	HYDROSTATIC TYPE	UG-99b Bar(g)
SEISMIC DESIGN DATA	SITE CLASS: C SEISMIC ZONE=1 I=1.25,R:3.0 Fa:1.05/Fv:1.1 Ss:1.31/S1:0.46 z/h:0.0/ap:0.0	M.A.W.P	9.1 Bar(g)
		J.E (Shell/Head)	0.85/0.85
		R.T (Shell/Head)	SPOT/SPOT
SERVICE	VOC ABATEMENT FROM STYRENE STORAGE TANK EFFLUENT	HYDRO. TEST PRESSURE/POSITION	2.535/HORIZONTAL Bar(g)
LOCATION	OUTDOOR	P.W.H.T	NO
FLUID	Air+Styrene (3.5 g/Nm3)	INSULATION/FIRE PROOF	NO / NO
DENSITY (Min./Max.)	1.107/1.295	IMPACT TEST	NO
DESIGN TEMP.	85 °C	PAINTING	NO
OPERATING TEMP.(Min./Max)	5/52 °C	M.D.M.T(REQU./ Cal)	-5/-48 °C
		CORROSION ALLOWANCE	3.0 mm

MATERIAL LIST			
SHELL/HEAD	SA-516 70	ANCHOR BOLT	SA-36
FORGED FLANGE/BLIND	SA-105	LIFTING LUG/EARTH LUG	SA-516 70/S.S
PIPE	SA-106 B	NAME PLATE	SS 304
FITTING	A234 WPB	INTERNAL WELDED ATTACHMENT	SA-516 70
NOZZLE WELDED NECK	SA-516 70	CORROSION ALLOWANCE	3.0
GASKET	S.W. Type, Graphite filled with inner/outer S.S. rings.	P.W.H.T	NO
REINFORCING PAD	SA-516 70	INSULATION/FIRE PROOF	NO/NO
BODY FLANGE	N.A.	IMPACT TEST	NO
STUD BOLT/NUT	SA-193 B7/SA-194 2H	PAINTING	NO

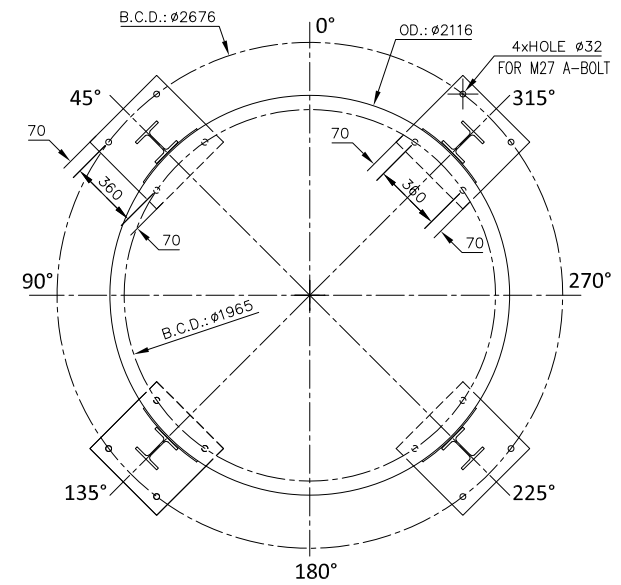

ANCHORAGE ARRANGMENT
SCALE 1:40

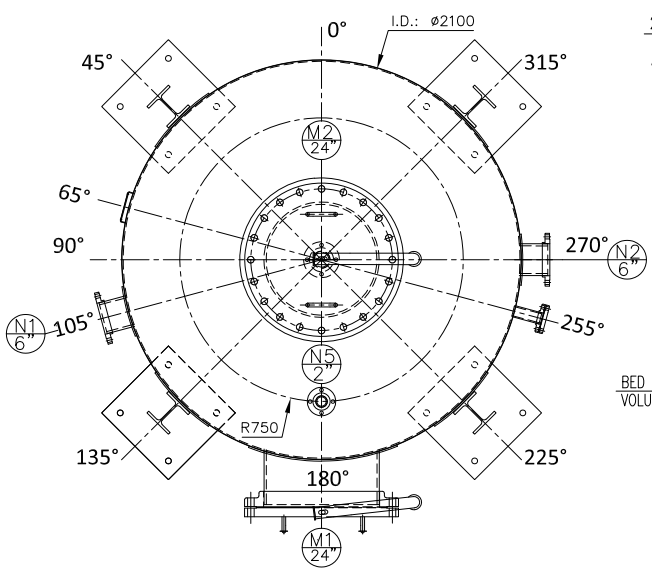

NOZZLE ORIENTATION
SCALE 1:40

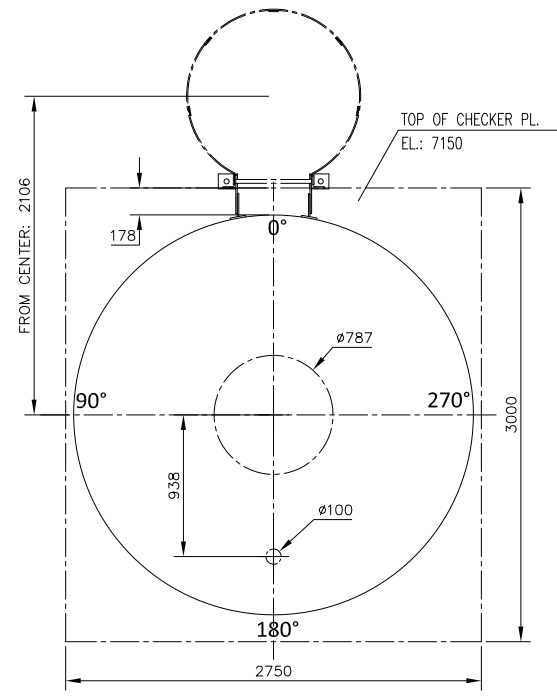

LADDER & PLATFORM LOCATION
SCALE 1:40

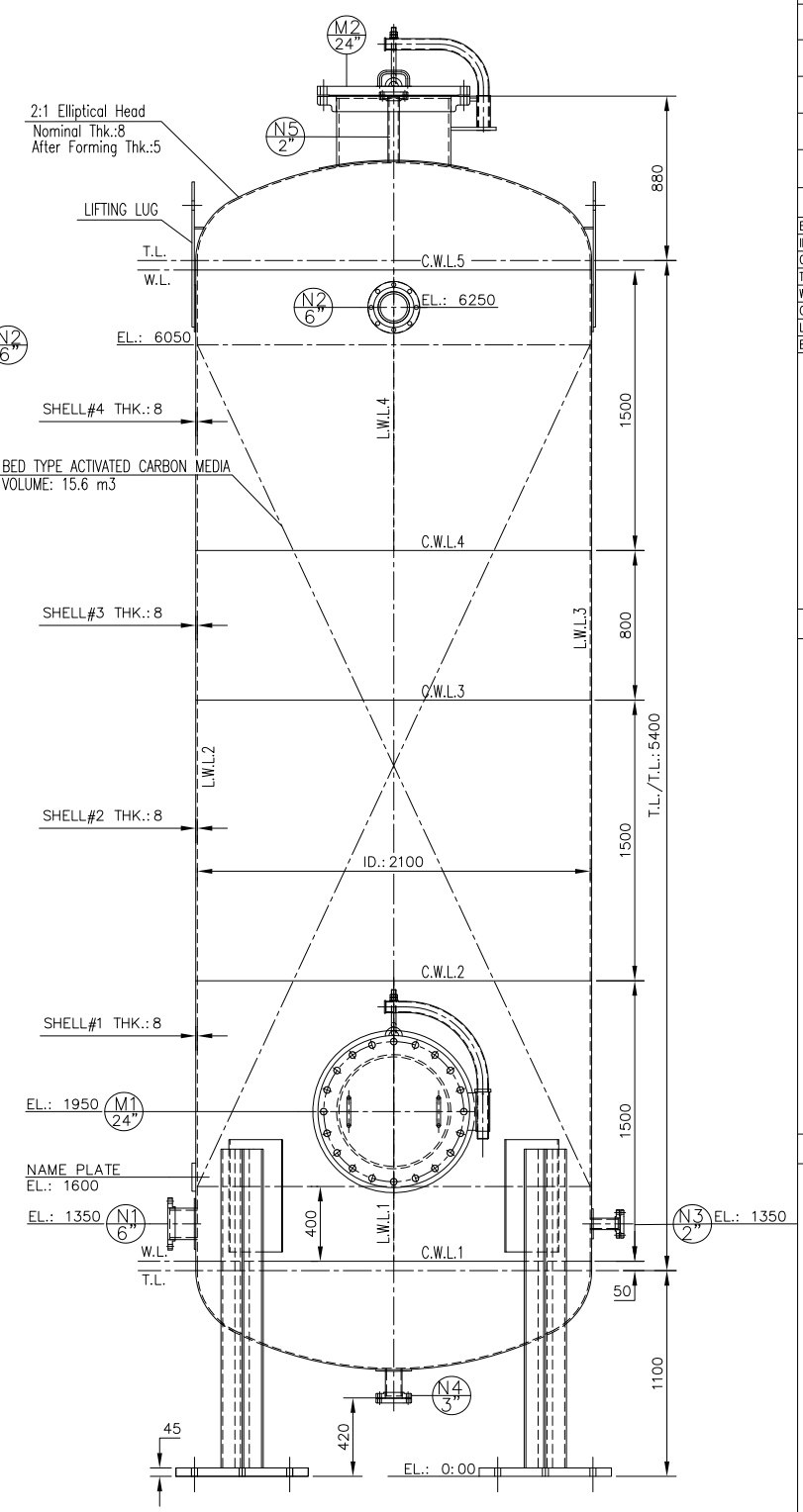

GENERAL FRONT VIEW
SCALE 1:40

NOZZLES DATA TABLE										
ITEM	QTY.	TITLE	SIZE	FLANGE			SCH/THK	REINFORCING PAD	PROJ./EL.	ORIENTATION
				RATING	TYP.	FACE				
N1	1	Gas Inlet	6"	#150	S.O.	R.F	80/-	270/8	150/1350	105° (SHL)
N2	1	Gas Outlet	6"	#150	S.O.	R.F	80/-	270/8	150/1350	270° (SHL)
N3	1	Utility Connection	2"	#150	S.O.	R.F	80/-	160/8	150/6250	270° (SHL)
N4	1	Drain	3"	#150	S.O.	R.F	STD/-	190/8	150/AS DWG	0° (BHD)
N5	1	Vent	2"	#150	S.O.	R.F	80/-	160/8	AS DWG	180° (SHE)
M1	1	Manhole	24"	#150	S.O.	R.F	-/8	1000/8	250/1950	180° (SHE)
M2	1	Manhole	24"	#150	S.O.	R.F	-/8	1000/8	350/AS DWG	0° (THD)

ALLOWABLE NOZZLE LOADS							
NAME	SIZE	(Kgf)			(Kg-m)		
		Fx	Fy	Fz	Mx	My	Mz
N3/N5	2"	64.8	-51.8	64.8	11.0	17.5	13.9
N4	3"	95.4	-76.2	95.4	23.6	38.3	30.2
N1/N2	6"	180.7	-144.4	180.7	84.4	136.2	106.9

WEIGHTS (Kgf)	
FABRICATED	4900.8
EMPTY	13122.0
OPERATING	14392.2
FIELD TEST	26170.9
UN-FACTORED FOUNDATION LOADS ON TOP OF ALL LEGS	
WIND SHEAR LOAD (Kgf)	1847.0
SEISMIC SHEAR LOAD (Kgf)	7867.0
WIND MOMENT LOAD (Kg-m)	4627.0
SEISMIC MOMENT LOAD (Kg-m)	26065.0

REFERENCE DRAWING	DWG NO.	REV.
P&ID	EI0127-ENR-VD-PR-PID-003	RO
Equipment Data Sheet-Active Carbon Filter	EI0127-ENR-VD-ME-DSH-001	RO
Strength Calculation-Active Carbon Filter	EI0127-ENR-VD-ME-CAL-003	RO
GAD For Package	EI0127-ENR-VD-PI-DWG-001	RO

LEGENDS :			
EL:	ELEVATION	UNCR:	UN CORRODED
ID:	INTERNAL DIAMETER	CR:	CORRODED
OD:	OUTSIDE DIAMETER	M.A.W.P:	MAX. ALLOWABLE WORKING PRES.
T.L:	TANGENT LINE	J.E:	JOINT EFFICIENCY
W.L:	WELD LINE	R.T:	RADIOGRAPHY TEST
C.W.L:	CIRCUMFERENTIAL WELD LINE	P.W.H.T:	POST WELD HEAT TREATMENT
L.W.L:	LONGITUDINAL WELD LINE	M.D.M.T:	MIN. DESIGN METAL TEMP.
B.C.D.:	BOLT CENTER DIAMETER		

NOTES :	
1-	ALL DIMENSIONS ARE IN MILLIMETER UNLESS OTHERWISE SPECIFIED.
2-	ALL THICKNESS SHOWN ON THIS DOCUMENT SHALL BE CONSIDERED AS A MINIMUM REQUIRED THICKNESS AFTER FORMING.
3-	FLANGE BOLT HOLES SHALL BE STRADDLE TO EQUIPMENT MAIN AXIS.
4-	FLANGE SURFACE FINISH ACCORDING TO ASME B16.5
5-	HYDROSTATIC TEST PRESSURE SHALL BE ACCORDING TO UG-99 (B)
6-	ONE EARTH LUGS HAS BEEN CONSIDERED ON LEG.
7-	BOTTOM OF BASING PLATES HAS ELEVATION OF EL. 0.00 mm
8-	ALL PROJECTIONS OF THE NOZZLES ON THE SHELL ARE MEASURED FROM THE FLANGE FACE TO THE VESSEL CENTERLINE.
9-	ALL PROJECTIONS OF THE NOZZLES ON THE HEAD ARE MEASURED FROM THE FLANGE FACE TO THE LOWER HEAD T.L. (i.e. B.L.).
10-	THE MANHOLE INCLUDES BLIND FLANGE WITH DAWT, GASKET, STUD BOLTS, AND NUTS.
11-	ALL REMOVABLE INTERNALS (IF ANY) WILL BE DESIGNED TO PASS THROUGH THE MANHOLE.
12-	SPIRAL WOUND GASKETS ARE MADE FROM S.S. 316 FOR INNER RING, GRAPHITE FIBER FOR WINDING, AND C.S. FOR OUTER RING.
13-	ANY MATERIAL DIRECTLY WELDED TO THE BODY SHALL BE THE SAME AS THE BODY MATERIAL.
14-	THE REPORTED M.A.W.P. BELONGS TO THE VESSEL'S BODY.
15-	PAINTING IS CONDUCTED AS PER THE "TEST PROCEDURES" DOC. MENTIONED IN THE REFERENCE DOC. LIST.
16-	ALLOWABLE NOZZLE LOADS ARE APPLIED TO THE JUNCTION OF THE NOZZLE NECK WITH THE VESSEL.
17-	ALL REINFORCEMENT PADS SHALL HAVE ONE VENT HOLE OF 6mm IN DIAMETER. THE HOLE SHALL BE FILLED WITH ANTI-CORROSION MATERIAL, e.g. GREASE, AFTER AIR SOAP TEST.

KEY PLAN :						
RO	04-Mar-24	Issued for Approval	M.T.	E.M.	H.K.	HRCO
REV.	ISSUE DATE	DESCRIPTION	PREPARED	CHECKED	APPROVED	COMPANY

CLIENT:		CONSULTING ENGINEER:	

PROJECT:			
STYRENE PARK OFFSITE			
DRAWING TITLE:			
General Arrangement Drawing-Active Carbon Filter			
DRAWING NO.	REV.	SIZE	SHEET
EI0127-ENR-VD-ME-DWG-005	RO	A3	AS DWG 3 of 3