

VEM Motor MV datasheet:

Please consider Ex certification is valid from -20 - +48°C

**Three-phase motors with squirrel cage rotor, explosion protected version,
protection type 'Ex ec', device group II, category 3G**

Type		W52R 355 M2 Ex ec IIC T3 Gc DR PT NS LL HW
Standard marking		Ex ec IIC T3 Gc
Duty type		S1
Design output	(kW)	150
Design torque	(Nm)	1041
Design frequency	(Hz)	50
Design speed	[rpm]	2981
Direction of rotation		right
Design voltage	(V)	6.000
Connection	[-]	Y
Design current	[A]	35.7
Relative pull-in current	[-]	6,2
Relative starting torque	[-]	1
Relative pull-out torque	[-]	2,5
Power factor	[-]	0,92
Efficiency	[%]	95,6
Efficiency determination	[-]	EN 60034-2-1
ATEX-No.		IBExU16ATEXB016 Ausgabe 0
Th. cl.		155(F/B)
Coolant temperature	(°C)	-20...+48
Altitude above sea level	(m)	1850
Degree of protection IP		IP55
Moment of inertia	(kgm ²)	4,22
Motor weight	(kg)	2100
Bearing, D-side		6317 C3
Bearing, N-side		6317 C3
Relubrication interval	(h)	2000
Grease type		ASONIC GHY 72
Grease amount	[cm ³]	57/57
A-sound pressure level	(dB)	

Options

Type of mounting		IM B3
Flange		-
Terminal box		Ex - version
Position of terminal box		at an angle / right
Cable gland		M 63x1,5 MS
Position of cable entry		
Shaft		Standard, 1 shaft end
Bearing		Relubrication device, easy bearing arrangement
Special details to bearings		Fixed bearing, N-side
Winding protection		3xPt 100 (4-wire-connection, Ex i)
Limit values to vibration velocity		Class A
		Balancing with half key
Colour system		01 Moderate (KK C2),RAL 7031 blue-grey
Delivery conditions and/or official regulations:		IEC / EN 60034-1
This document was produced electronically, all specifications are valid only after confirmation of the manufacturer		

Three-phase motors with squirrel cage rotor, explosion protected version,
protection type 'Ex ec', device group II, category 3G

W52R 355 M2 Ex ec IIC T3 Gc DR PT NS LL HW

Mounting position

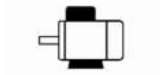

Type of mounting: IM B3
 Flange: -
 Position of terminal box: at an angle / right
 Brake type:
 Forced-ventilation:

Terminal box: EXE-KA 6,6KV 400A
 Cable gland O: 3 xM 63x1,5 MS

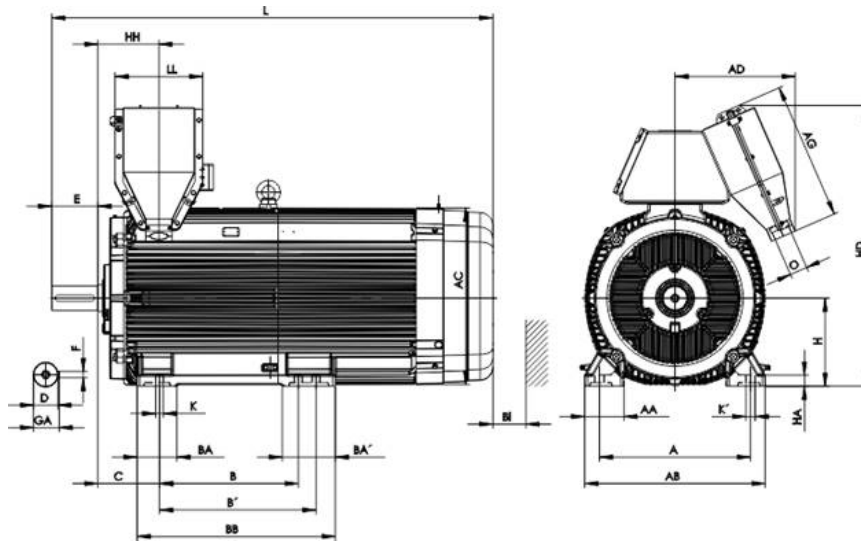

Motor

A	AA	AB	AC	AD	B	B'	BA	BA'	BB	C	CA	K	K'	
610	128	700	704		560	630	139	199	750	254	-	28	35	
											Protection cover		Terminal box	
L	LC	H	HA	HD	HH	BI	L		AG	LL	BE	AH		
1730	-	355	44	1167	265	110			643	448				
											Tolerances			
Flange											H	N	D	DA
P N LA M T S											-1	h6	m6	m6
Shaft-DS											Shaft-NS			
D	E	GA	F	DB	DA	EA	GC	FA						
80	170	85	22	DIN332DS-M20	-	-	-	-						

DB...Centre hole

Delivery conditions and/or official regulations: IEC / EN 60034-1

This document was produced electronically, all specifications are valid only after confirmation of the manufacturer