



Toase-eh Park Sanati Gohar Ofogh
Petrochemical Co.
**CONCEPTUAL, BASIC and DETAIL DESIGN
ENGINEERING OF STYRENE PARK OFFSITE**



Document Title: Tube Expanding Procedure

Document No.: EI027-DMF-VD-QC-PRO-026

Rev. R2

Page 1 of 11

STYRENE PARK OFFSITE

Document Title:
Tube Expanding Procedure

Rev.	Issued Date	DESCRIPTION	PREPARED	CHECKED	APPROVED
R2	23-Dec.-2024	IFA	A.Parsafar	A.Shadmand	M.Heidarzadeh
R1	10-Dec.-2024	IFA	A.Parsafar	A.Shadmand	M.Heidarzadeh
R0	06-Oct.-2024	IFA	A.Parsafar	A.Shadmand	M.Heidarzadeh



Toase-che Park Sanati Gohar Ofogh
Petrochemical Co.
**CONCEPTUAL, BASIC and DETAIL DESIGN
ENGINEERING OF STYRENE PARK OFFSITE**



Document Title: Tube Expanding Procedure

Document No.: EI027-DMF-VD-QC-PRO-026

Rev. R2

Page 2 of 11

REVISION RECORD SHEET

Page	Revisions							Page	Revisions						
	R0	R1	R2	R3	R4	R5	R6		R0	R1	R2	R3	R4	R5	R6
1	X	X	X					41							
2	X	X	X					42							
3	X	X						43							
4	X							44							
5	X							45							
6	X							46							
7	X	X						47							
8	X	X	X					48							
9	X	X						49							
10		X						50							
11		X						51							
12								52							
13								53							
14								54							
15								55							
16								56							
17								57							
18								58							
19								59							
20								60							
21								61							
22								62							
23								63							
24								64							
25								65							
26								66							
27								67							
28								68							
29								69							
30								70							
31								71							
32								72							
33								73							
34								74							
35								75							
36								76							
37								77							
38								78							
39								79							
40								80							









 	Toase-eh Park Sanati Gohar Ofogh Petrochemical Co. CONCEPTUAL, BASIC and DETAIL DESIGN ENGINEERING OF STYRENE PARK OFFSITE	 	
	Document Title: Tube Expanding Procedure	Rev. R2	Page 3 of 11
	Document No.: EI027-DMF-VD-QC-PRO-026		

Table of Contents

1.0	PURPOSE
2.0	SCOPE
3.0	REFERENCES
4.0	DEFINITION
5.0	EQUIPMENT SPECIFICATION
6.0	TUBE HOLE GROOVING
7.0	Expanded tube-to-tube sheet joints
8.0	CLEANING BEFORE EXPANSION
9.0	EXPANSION CRITERIA
10.0	CHECKING OF THE EXPANSION
11.0	WORK SEQUENCE
12.0	Appendix I: sample inspection report,

 	Toase-eh Park Sanati Gohar Ofogh Petrochemical Co. CONCEPTUAL, BASIC and DETAIL DESIGN ENGINEERING OF STYRENE PARK OFFSITE	 
	Document Title: Tube Expanding Procedure	
	Document No.: EI027-DMF-VD-QC-PRO-026	Rev. R2 Page 4 of 11

1.0. PURPOSE

This procedure describes the practical application of the strength expanding operation for tube-to-tube sheet of Air-cooled heat exchangers Project: “Toase-eh Park Sanat Gohar Ofogh Petrochemical Co.

CONCEPTUAL, BASIC and DETAIL DESIGN ENGINEERING OF STYRENE PARK OFFSITE”.

2.0. SCOPE

This method is used for the expansion of tubes in a standard air-cooled exchanger when the yield strength of the tube sheet is superior to the yield stress of the tube. Therefore, the plastic deformation of the tube during the expansion process includes BWG 10 to BWG16, which are categorized according to the outer diameter and wall thickness-refer to Appendix Table1. This procedure shall provide essentially uniform expansion throughout the expanded portion of the tube without a sharp transition to the unexpanded portion.

3.0. REFERENCES

API 661: Air-Cooled Heat Exchangers

4.0. DEFINITION

B.W.G: Birmingham wire gauge

d_i = inner diameter of the tube after expansion

d_0 = inner diameter of the tube before expansion





H= diameter of the tube sheet plate hole

D = outer diameter of the tube before expansion

%ER= expansion ratio%

5.0. EQUIPMENT SPECIFICATION

TROUVAY & ARUVIN LE HAVRE FRANCE TYPE:
TCM3

 	Toase-eh Park Sanati Gohar Ofogh Petrochemical Co. CONCEPTUAL, BASIC and DETAIL DESIGN ENGINEERING OF STYRENE PARK OFFSITE	 
	Document Title: Tube Expanding Procedure	
	Document No.: EI027-DMF-VD-QC-PRO-026	Rev. R2 Page 5 of 11

6.0. TUBE HOLE GROOVING

All tube sheet holes for expanded joints in tube sheets less than 1inch (25mm) thick shall be machined with one groove approximately 1/8 inch (3 millimetres)wide by 1/64 inch (0.4millimeter) deep. A second groove shall be provided for tube sheets 1inch (25millimeters) or greater in thickness.

Grooves shall be located at least 1/8 inch (3mm.) plus corrosion allowance from the process face of the tube sheet and at least ¼ inch (6millimeters) from the airside face of the tube sheet.

Tube-hole grooves shall be square-edged, concentric and free of burrs.

7.0. Expanded tube-to-tube sheet joints

Tubes shall be expanded into the tube sheet for a length at least the smaller of the following:

- a) 50 mm (2 in)
- b) The tube sheet thickness less 3 mm (1/8 in).





In no case shall the expanded portion extend beyond the air-side face of the tube sheet.

The ends of tubes shall extend at least 1.5 mm (1.6 in) and not more than 10mm (3/8 in) beyond the tube sheet.

8.0. CLEANING BEFORE EXPANSION

The tube sheet bores must be cleaned before tubing and must be free from barbs at the level of the expansion grooves.

The inner bore of the tube must be smooth, free from barbs and swellings which would jeopardize the good expansion process.

 	Toase-eh Park Sanati Gohar Ofogh Petrochemical Co. CONCEPTUAL, BASIC and DETAIL DESIGN ENGINEERING OF STYRENE PARK OFFSITE	  
	Document Title: Tube Expanding Procedure	
	Document No.: EI027-DMF-VD-QC-PRO-026	Rev. R2 Page 6 of 11

9.0. EXPANSION CRITERIA:

To obtain the permissible expansion range in the inner diameter of the tube, we consider the internal expansion of the tube in the plastic range.

so that the tube sheet is still elastic and after removing the expansion force, it is closed by returning to the original state.

This condition is created when the expansion ratio ER % is defined as the following relationship:

$$\% ER = \frac{(d_i - d_o) - (H - D)}{(D - d_o)} \times 100$$

% ER Is situated in the following range: 3 % ≤ ER% ≤ 10 %

for tubes with gauge BWG 12 to 16

10.0. CHECKING OF THE EXPANSION

Due to the application of tube-to-tube sheet weld in the connection of tube and tube sheet: the expansion of tube sheet to tube is done in two stages:





The first step is a small expansion to help escape the welding fumes and fix the tube to the hole in the tube sheet, and there is no need to measure the corresponding amount.

The final expansion rate after full expansion is measured and reported according to **Table 1**.

The expansion operation inside the tube goes back to the first 10 samples.

As a result, the normal value of the expansion force is determined by adjusting the ampere device.

The obtained result is applied to all tubes. Finally, the inner diameter of the pipes after expansion is measured and recorded. This diameter should be within the range of parameter "di" in **Table 1**.

 	Toase-eh Park Sanati Gohar Ofogh Petrochemical Co. CONCEPTUAL, BASIC and DETAIL DESIGN ENGINEERING OF STYRENE PARK OFFSITE		 		
	Document Title: Tube Expanding Procedure			Rev. R2	Page 7 of 11
	Document No.: EI027-DMF-VD-QC-PRO-026				

ITEM No.'s	BWG	Min. Wall THK.	OD	H(mm)	Range Of heavy exp%	d0	Range of di
Air cooler	16	1.651	25.4	25.7	3~10	22.098	22.49~22.79

Range of Expanding L (light), H (Heavy)

Range of di: The limits of "di" values are calculated according to the percentage of permissible expansion from 3% to 10% using the ER% relationship.

The suitable mandrel model is selected according to the thickness of the tube wall and the outer diameter of the tube according to the BWG table.

The expansion on the tubes and the holes of the tube sheet is done according to the ampere and power settings of the device.

The final expansion efficiency is checked during the hydrostatic test, and in case of leakage from the expanded area, by re-expanding up to the maximum allowed range, the sealing of the area is ensured. The results obtained will be reported in the inspection report.

11.0 work sequence

According to the connection plan (picture 1) and work chart (picture 2), first the tube is welded to the tube sheet and then EXPAND is done.

According to NDT Map (EI027-DMF-VD-QC-PRO-023), NDT tests are not possible in this type of connection.

Leak test according to Hydrostatics Procedure. is done.



Toase-eh Park Sanati Gohar Ofogh
Petrochemical Co.
**CONCEPTUAL, BASIC and DETAIL DESIGN
ENGINEERING OF STYRENE PARK OFFSITE**



Document Title: Tube Expanding Procedure

Document No.: EI027-DMF-VD-QC-PRO-026

Rev. R2

Page 8 of 11

picture 1

**WELD NO. 8
DS11-W025/01**

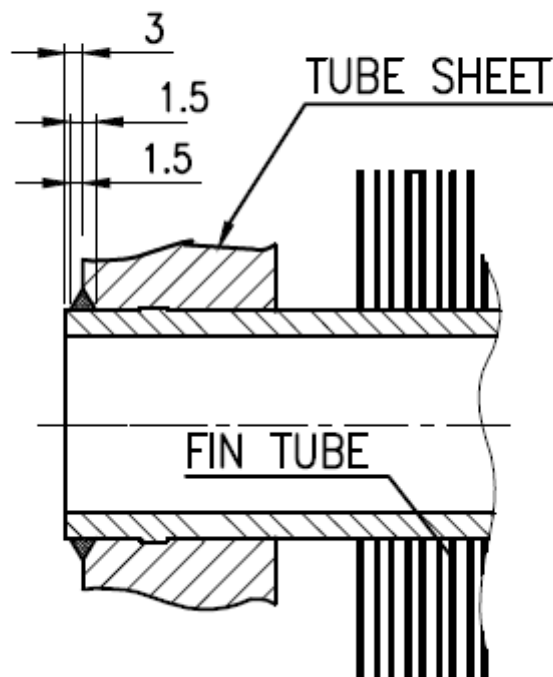

WPS & PQR for Pressure Part and Structure: EI027-DMF-VD-QC-WPS-022(Page 3)

Weld No.	WPS NO :	PQR	ITEM NO.	WELD DISCRIPTION	Designation	Material	Thk.(mm)
8	DS11-W025/01	P052	EI027-DMF-VD-ME-DWG-005	TUBE SHEET TO TUBE	FILLETWELD-T-JOINT	ASME SA334 GR.6 TO ASME SA516 Gr.70	1.65 TO 20



Toase-eh Park Sanati Gohar Ofogh
Petrochemical Co.
**CONCEPTUAL, BASIC and DETAIL DESIGN
ENGINEERING OF STYRENE PARK OFFSITE**



Document Title: Tube Expanding Procedure

Document No.: EI027-DMF-VD-QC-PRO-026



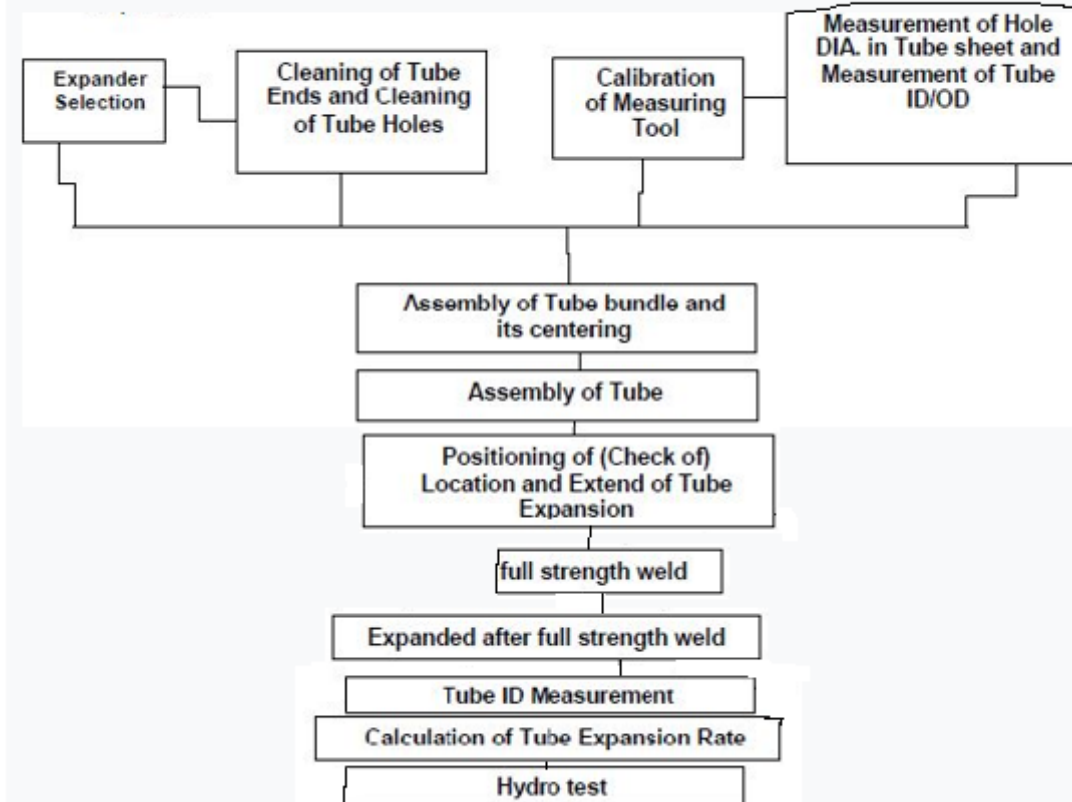

Rev. R2

Page 9 of 11

work chart



12.0 Appendix I: sample inspection report,

 		Tube Expanding Report		 			
Project Name / Dtt Job No :		Toase-eh Park Sanati Gohar Ofogh Petrochemical Co.					
Reference Document Name / No		Tube Expanding Procedure EI027-DMF-VD-QC-PRO-026					
Item no :		Air Cooler					

Tube Bundle No :						Standard Dimensions		
Front Tube Sheet No:	Rear Tube Sheet No:	Number Of Holes	B.W.G	Expansion Rate %	D	d0	H (mm)	di (rate)

Front Tube Sheet								Rear Tube Sheet							
Item	di (mm)	% ER	Result	Item	di (mm)	%ER	Result	Item	di (mm)	% ER	Result	Item	di (mm)	% ER	Result
1			Ok	11			Ok	1			Ok	11			
2				12				2				12			
3				12				3				12			
4				12				4				12			
5				12				5				12			
6				12				6				12			
7				12				7				12			
8				12				8				12			
9				12				9				12			
10				20				10				20			

<p>D: Tube external diameter before expanding d0: Tube internal diameter before expanding H: Tube sheet hole diameter di: Tube internal diameter after expanding ER: Expansion rate ER</p>	$\% ER = \frac{(d_i - d_0) - (H - D)}{(D - d_0)} \times 100$
---	--

DTT	CONTRACTOR	TPA	CLIENT
Name : Date: Sing:	Name : Date: Sing:	Name : Date: Sing:	Name : Date: Sing:



CHECKING OF THE EXPANSION PROCEDURE

Acceptance ranges for the inner diameter of tube after expansion (di)

Size	BWG	Wall thk(mm)	D	H(mm)	ER%	dO	di	roller		
								Comp. Tool No	Mandrel No	Set of Roller
1"	10	3.403	25.4	25.7	According to customer requirements bet	18.594	The minimum and maximum are calculated by inserting the Exp% in the formula	C1237	CM61	CR15
	11	3.048	25.4	25.7		19.304		C1243	CM62	CR16
	12	2.768	25.4	25.7		19.864		C1245	CM62	CR17
	13	2.413	25.4	25.7		20.574		C1247	CM62	CR18
	14	2.108	25.4	25.7		21.184		C1249	CM63	CR18
	15	1.828	25.4	25.7		21.744		C1251	CM63	CR19
	16	1.651	25.4	25.7		22.098		C1251	CM63	CR19
1 1/4"	10	3.403	31.75	32.11		24.944		C1263	CM65	CR24
	11	3.048	31.75	32.11		25.654		C1267	CM66	CR26
	12	2.768	31.75	32.11		26.214		C1269	CM66	CR27
	13	2.413	31.75	32.11		26.924		C1271	CM67	CR28
	14	2.108	31.75	32.11		27.534		C1273	CM67	CR29
	15	1.828	31.75	32.11		28.094		C1275	CM67	CR30
	16	1.651	31.75	32.11		28.448		C1275	CM67	CR30
1 1/2"	10	3.403	38.1	38.56		31.294		C1287	CM 70	CR 35
	11	3.048	38.1	38.56		32.004		C1291	CM 70	CR 36
	12	2.768	38.1	38.56		32.564		C1293	CM 70	CR 37
	13	2.413	38.1	38.56		33.274		C1295	CM 71	CR 37
	14	2.108	38.1	38.56		33.884		C1295	CM 71	CR 37
	15	1.828	38.1	38.56		34.444		C1297	CM 71	CR 38
	16	1.651	38.1	38.56		34.798		C1297	CM71	CR38

Roler model : TROUVAY & ARUVIN LE HAVRE FRANCE TYPE: TCM3