



Toase-eh Park Sanati Gohar Ofogh
Petrochemical Co.
**CONCEPTUAL, BASIC and DETAIL DESIGN
ENGINEERING OF STYRENE PARK OFFSITE**



dttdamafin
thermal technology

Document Title: Vibration Switch Data Sheet

Document No.: EI027-DMF-VD-IN-DSH-019-R3

Rev. R3

Page 1 of 8

STYRENE PARK OFFSITE

**Document Title:
Vibration Switch Data Sheet**

| | | | | | |
|-------------|--------------------|--------------------|-----------------|----------------|-----------------|
| R3 | 02-11-2024 | IFA | F.Aghaienezhad | J.Beigloo | A.Gholizadeh |
| R2 | 06-10-2024 | IFA | F.Aghaienezhad | J.Beigloo | A.Gholizadeh |
| R1 | 17-09-2024 | IFA | F.Aghaienezhad | J.Beigloo | A.Gholizadeh |
| R0 | 22-06-2024 | IFA | F.Aghaienezhad | J.Beigloo | A.Gholizadeh |
| Rev. | Issued Date | DESCRIPTION | PREPARED | CHECKED | APPROVED |



Toase-eh Park Sanati Gohar Ofogh
Petrochemical Co.
**CONCEPTUAL, BASIC and DETAIL DESIGN
ENGINEERING OF STYRENE PARK OFFSITE**



Document Title: Vibration Switch Data Sheet





Document No.: EI027-DMF-VD-IN-DSH-019-R3

Rev. R3

Page 2 of 8

REVISION RECORD SHEET

| Page Page | Revisions | | | | | | | Page | Revisions | | | | | | |
|--------------|-----------|----|----|----|----|----|----|------|-----------|----|----|----|----|----|----|
| | R0 | R1 | R2 | R3 | R4 | R5 | R6 | | R0 | R1 | R2 | R3 | R4 | R5 | R6 |
| 1 | X | X | X | X | | | | 41 | | | | | | | |
| 2 | X | X | X | X | | | | 42 | | | | | | | |
| 3 | X | X | X | X | | | | 43 | | | | | | | |
| 4 | | X | X | X | | | | 44 | | | | | | | |
| 5 | | X | X | X | | | | 45 | | | | | | | |
| 6 | | X | X | X | | | | 46 | | | | | | | |
| 7 | | X | X | X | | | | 47 | | | | | | | |
| 8 | | X | X | X | | | | 48 | | | | | | | |
| 9 | | X | | | | | | 49 | | | | | | | |
| 10 | | | | | | | | 50 | | | | | | | |
| 11 | | | | | | | | 51 | | | | | | | |
| 12 | | | | | | | | 52 | | | | | | | |
| 13 | | | | | | | | 53 | | | | | | | |
| 14 | | | | | | | | 54 | | | | | | | |
| 15 | | | | | | | | 55 | | | | | | | |
| 16 | | | | | | | | 56 | | | | | | | |
| 17 | | | | | | | | 57 | | | | | | | |
| 18 | | | | | | | | 58 | | | | | | | |
| 19 | | | | | | | | 59 | | | | | | | |
| 20 | | | | | | | | 60 | | | | | | | |
| 21 | | | | | | | | 61 | | | | | | | |
| 22 | | | | | | | | 62 | | | | | | | |
| 23 | | | | | | | | 63 | | | | | | | |
| 24 | | | | | | | | 64 | | | | | | | |
| 25 | | | | | | | | 65 | | | | | | | |
| 26 | | | | | | | | 66 | | | | | | | |
| 27 | | | | | | | | 67 | | | | | | | |
| 28 | | | | | | | | 68 | | | | | | | |
| 29 | | | | | | | | 69 | | | | | | | |
| 30 | | | | | | | | 70 | | | | | | | |
| 31 | | | | | | | | 71 | | | | | | | |
| 32 | | | | | | | | 72 | | | | | | | |
| 33 | | | | | | | | 73 | | | | | | | |
| 34 | | | | | | | | 74 | | | | | | | |
| 35 | | | | | | | | 75 | | | | | | | |
| 36 | | | | | | | | 76 | | | | | | | |
| 37 | | | | | | | | 77 | | | | | | | |
| 38 | | | | | | | | 78 | | | | | | | |
| 39 | | | | | | | | 79 | | | | | | | |
| 40 | | | | | | | | 80 | | | | | | | |

| | | |
|---|---|--|
|   | Toase-eh Park Sanati Gohar Ofogh Petrochemical Co. CONCEPTUAL, BASIC and DETAIL DESIGN ENGINEERING OF STYRENE PARK OFFSITE |   |
| | Document Title: Vibration Switch Data Sheet | |
| | Document No.: EI027-DMF-VD-IN-DSH-019-R3 | Rev. R3 |

| Vibration Switch Data sheet | | | | | | | | | | |
|-----------------------------|------------------------|--|-----|--------|-------------------|-------------------------|--------------------------|------------------------------|-----|----------|
| Basic Data | | | | | Manufacturer Data | | | | | |
| 1 | PROJECT- Customer item | 1158 | | | 1 | Manufacturer / Origin | SAMI/ Italy | | | |
| 2 | Quantity | 4 | | | 2 | Type - Model | VBS SPDT without M20*2.5 | | | |
| 3 | Tag No. | VS-RU0001A-01A VS-RU0001A-01B VS-RU0001B-01A VS-RU0001B-01B | | | 3 | Enclosure material | Cast aluminum painted | | | |
| 4 | Area classification | IEC | Yes | | | 4 | Certification | According to 2014/34/EU ATEX | | |
| 5 | | NEMA | Yes | | | 5 | Working | HORIZONTAL | Yes | VERTICAL |
| 6 | Enclosure | Exd | | | 6 | Wiring entry(type-size) | M20 | | | |
| 7 | Reset | Electric | NO | Manual | YES | 7 | CABLE GLAND | M20*1.5 | | |
| 8 | Switch contacts | SPDT | YES | DPDT | NO | 8 | RANGE | 0-5g | | |
| 9 | Protection | IP 65 | | | 9 | TEMP CLASS | T5 | | | |
| 10 | Zone - Gas group | 2 | | | 10 | Normal Operation Temp | (-20, 55) °C | | | |
| 11 | RANGE - SET POINT | (0- 5 g) | | | | | | | | |
| 12 | Temperature class | IIB-T3 | | | 11 | Set point adjust | 2g | | | |
| 13 | Ambient temp. min/max | (5 To 48) °C | | | 12 | RESET | MANUAL | | | |
| 14 | Humidity (RH) (%) | 80% | | | 13 | PROTECTION | IP65 | | | |
| 15 | Altitude (m) | 20 | | | 14 | | | | | |
| 16 | Contact rating | 24VDC, 1A | | | 15 | | | | | |
| 17 | Start-up delay | N.A | | | 16 | | | | | |
| 18 | MOUNTING | Yes | | | 17 | | | | | |
| 19 | Housing | CAST ALUMINIUM | | | 18 | | | | | |
| 20 | Thered size - TYPE | M20 @ 1.5 | | | 19 | | | | | |

Compact vibration switch, flameproof enclosure Ex D Model VBS

WIKA data sheet PR XX.XX



for further approvals see
page 4

Applications

- Monitor excess of vibrations in machinery equipments
- Safety-critical applications in chemical and petrochemical industries, oil and gas, power generation, including nuclear power plants, water/wastewater, mining
- Ventilation / Air conditioning
- Pumps & compressors, turbines
- Engines, motors & generators

Special features

- Robust switch enclosure from aluminium alloy
- Frequency sensitivity up to 60 Hz (< 3600 RPM)
- SPDT or DPDT contacts, up to AC 380 Vac, 15 A
- Calibration: up to 5 g with outer calibration screw

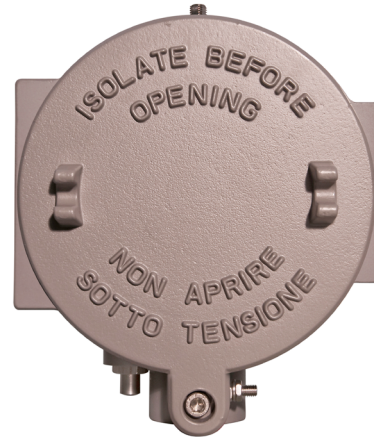

Model VBS

Description

The Vibration switches have been developed to protect the rotating equipments against increase in vibration due to operating anomalies or failures that could damage the entire machinery.

The high quality of the products and manufacturing in accordance with ISO 9001 ensure reliable monitoring of your machine. During the production phase the switches are 100% calibrated and tested.

The switches are of mechanical type. The robust switch enclosure from aluminium alloy can withstand the rough and corrosive operating conditions of the process industry.

To adjust the set point simply open the access cover plate. The access to the terminal block for the electrical connection is protected by a screw-on lid, which is secured with a screw-

type lock against unauthorised intervention.

The vibration switches have a frequency sensitivity up to 60Hz and can be calibrated up to 5g acceleration directly in field.

Vibrations Switches contain a spring inside the body.

The excessive vibration, beyond a defined range, causes the movement of the spring, which consequently activates the switch through magnetic attraction.

The position of the magnet in relation to the spring can be changed to match the desired threshold value.

Disengaging the magnet from the spring will reset the Vibration Switch.

In order to ensure operation as flexible as possible, the Vibration switches are fitted with micro switches which enable the switching of an electrical load of up to AC 380V 15A directly.

Specifications

| Specifications | |
|------------------------------|---|
| Enclosure material | High resistance aluminium alloy. Max copper content: 1% |
| Ignition protection | CESI Flameproof, Ex d IIC T6 or T5 Gb |
| Switch enclosure | Epoxy resin coated and tamper-proof junction box and terminal box provided together with the equipment |
| Peak vibration range | 5 g |
| Calibration | 0 to 5g with outer calibration screw ¹⁾ |
| Frequency sensitivity | 0 to 60 Hz (0 ÷ 3600 RPM) |
| Mechanical protection | IP 65 & CE mark |
| Working axes | 2 Axis only (A-B see picture) |
| Ambient Temperature | <ul style="list-style-type: none"> ■ -20°C +40°C for temperature class T6 ■ -20°C +55°C for temperature class T5 |
| Capacity of contacts | <ul style="list-style-type: none"> ■ SPDT 15A @ 0÷380 Vac ■ DPDT 10A @ 0÷250 Vac |
| Start-up delay | Optional reset coil required ²⁾ |
| Reset | <ul style="list-style-type: none"> ■ Local reset is provided as standard ■ Electrical Remote Reset can be supplied as optional |
| Weight | 3 kg (including bracket and fixing screws) |
| Earth screws | Internal and external |
| Terminal box | Suitable for cable up to 2,5 mm ² |
| Installation | With fixing base or bracket. The vibration sensitive axle is perpendicular or axial to the switch fixing base |
| Label | Laser-engraved stainless steel nameplate fixed to the body, containing the following information: <ul style="list-style-type: none"> ■ Manufacturer name ■ Model ■ Serial Number ■ Range ■ Purchase Order number ■ Tag number |
| Reset coil | <ul style="list-style-type: none"> ■ None ■ 115/120 Vac ■ 220/230 Vac ■ 24 Vdc |
| Electrical connection | <ul style="list-style-type: none"> ■ M20 X 1,5 ■ ¾" NPT-F ■ 1/2" NPT-F |
| Switch contacts | <ul style="list-style-type: none"> ■ SPDT ■ DPDT |

¹⁾ The vibration switches are provided with a standard pre-set factory set-point. The set-point of the instrument strongly depends on the intensity of the natural vibration produced by the equipment during the normal operation. The final calibration of the vibration switch must be done on field according to the peculiarity of machinery on which the device is installed. For this reasons, due to the huge variables that depend on the equipment and application, WIKA does not provide any customized set-point or any calibration certificate of the instrument.

²⁾ Apply voltage to the reset coil to stop bounces for at least 20 seconds after the machine has started

Dimensions

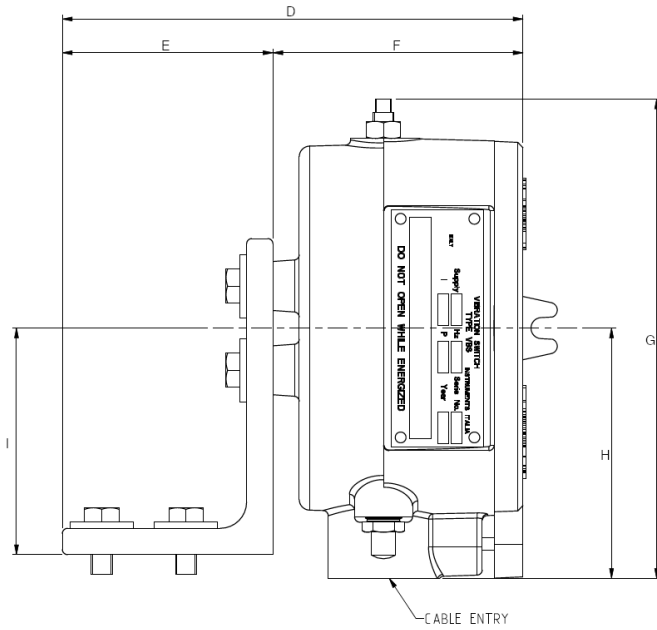
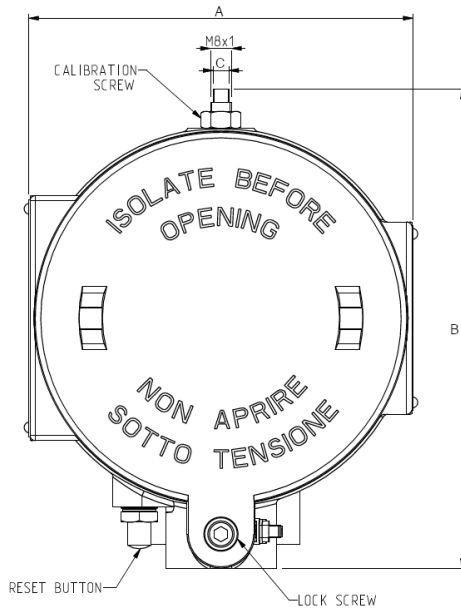

| Dimensions in mm [in] | | | | | | | | |
|-----------------------|------------|----------|------------|-----------|-----------|------------|-----------|-----------|
| A | B | C | D | E | F | G | H | I |
| 146 [5.75] | 182 [7.16] | 6 [0.24] | 175 [6.89] | 80 [3.15] | 95 [3.74] | 182 [7.16] | 95 [3.74] | 86 [3.38] |

Single Switch Connection Electrical Diagram

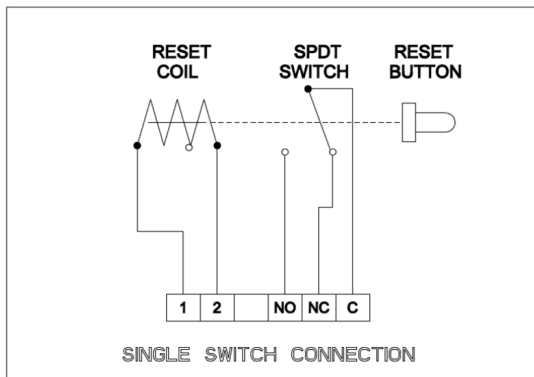

Double Switch Connection Electrical Diagram

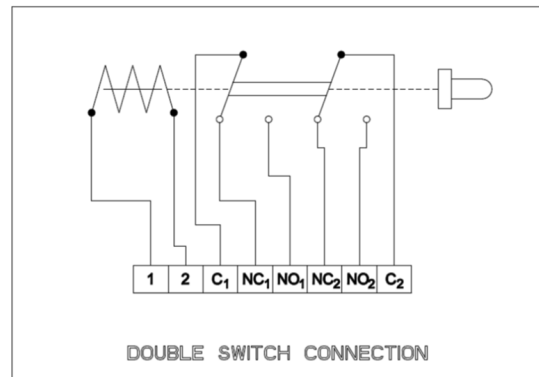

Ordering Information

| Item Number | Reset coil | Switch contacts | Electrical connections |
|-------------|------------|-----------------|---------------------------------------|
| 81647076 | 24 VDC | DPDT | ¾" NPT-F + ½" NPF-F adapter |
| 81647079 | 24 VDC | DPDT | ¾" NPT-F direct |
| 81647080 | 24 VDC | DPDT | M20x1,5 + Cable gland 11-18mm adapter |
| 81647083 | 24 VDC | DPDT | M20x1,5 direct |
| 81647077 | 24 VDC | SPDT | ¾" NPT-F + ½" NPF-F adapter |
| 81647078 | 24 VDC | SPDT | ¾" NPT-F direct |
| 81647081 | 24 VDC | SPDT | M20x1,5 + Cable gland 11-18mm adapter |
| 81647082 | 24 VDC | SPDT | M20x1,5 direct |
| 81647168 | 110 VAC | DPDT | ¾" NPT-F + ½" NPF-F adapter |
| 81647165 | 110 VAC | DPDT | ¾" NPT-F direct |
| 81647087 | 110 VAC | DPDT | M20x1,5 + Cable gland 11-18mm adapter |
| 81647084 | 110 VAC | DPDT | M20x1,5 direct |
| 81647167 | 110 VAC | SPDT | ¾" NPT-F + ½" NPF-F adapter |
| 81647166 | 110 VAC | SPDT | ¾" NPT-F direct |
| 81647086 | 110 VAC | SPDT | M20x1,5 + Cable gland 11-18mm adapter |
| 81647085 | 110 VAC | SPDT | M20x1,5 direct |
| 81647170 | 220 VAC | DPDT | ¾" NPT-F + ½" NPF-F adapter |
| 81647173 | 220 VAC | DPDT | ¾" NPT-F direct |
| 81647174 | 220 VAC | DPDT | M20x1,5 + Cable gland 11-18mm adapter |
| 81647177 | 220 VAC | DPDT | M20x1,5 direct |
| 81647171 | 220 VAC | SPDT | ¾" NPT-F + ½" NPF-F adapter |
| 81647172 | 220 VAC | SPDT | ¾" NPT-F direct |
| 81647175 | 220 VAC | SPDT | M20x1,5 + Cable gland 11-18mm adapter |
| 81647176 | 220 VAC | SPDT | M20x1,5 direct |
| 81647072 | Without | DPDT | ¾" NPT-F + ½" NPF-F adapter |
| 81647068 | Without | DPDT | ¾" NPT-F direct |
| 81647074 | Without | DPDT | M20x1,5 + Cable gland 11-18mm adapter |
| 81647071 | Without | DPDT | M20x1,5 direct |
| 81647073 | Without | SPDT | ¾" NPT-F + ½" NPF-F adapter |
| 81647069 | Without | SPDT | ¾" NPT-F direct |
| 81647075 | Without | SPDT | M20x1,5 + Cable gland 11-18mm adapter |
| 81647070 | Without | SPDT | M20x1,5 direct |

Approvals

| Logo | Description | Country |
|------|--|----------------|
| CE | <ul style="list-style-type: none">- EU Declaration of conformity- RoHS directive- ATEX directive- II 2G | European Union |

Approvals and certificates, see website

© 04/2021 WIKA Alexander Wiegand SE & Co. KG, all rights reserved.
The specifications given in this document represent the state of engineering at the time of publishing.
We reserve the right to make modifications to the specifications and materials.



WIKA Alexander Wiegand SE & Co. KG
Alexander-Wiegand-Straße 30
63911 Klingenberg/Germany
Tel. +49 9372 132-0
Fax +49 9372 132-406
info@wika.de
www.wika.de