

To be matched with final fan data sheet

Compatibility between related document is in vendor responsibility.

For Bolt and nuts 12 mm and above shall be Hot Dip Galvanized According to ASTM A153 (45~55 μ).

Please specify the connection on the top and bottom

Please refer to the doc. No also.

PART LIST

PART NO.	DESCRIPTION	DA	LENGTH	WIDTH	THK.	MATERIAL	QTY.	Unit Weight	Total Weight	REV.
5067-00	FAN RING INCLUDING:	-	-	-	-	-	4	168	670	
5067-01	SHEET 1/4 RING	-	1690	714	4	st-37(Galv.)	4	38	152	
5067-02	FIXING PLATE (BRACKET)	-	648	100	5	st-37(Galv.)	4	2	8	
5067-03	BOLT FOR TIE ROD	M12	680	-	-	DIN-976-1(Dacromet)	8	1	8	
5067-04	NUT FOR TIE ROD	M12	-	-	-	DIN-934-CL.8(Dacromet)	32	-	-	
5067-05	WASHER FOR TIE ROD	A13	-	-	-	DIN-125A-ST(Dacromet)	32	-	-	
5067-06	BOLT FOR FIXING PLATE	M12	30	-	-	DIN-933-CL.8(Dacromet)	16	-	-	
5067-07	BOLT FOR FIXING PLATE	M12	40	-	-	DIN-933-CL.8(Dacromet)	16	-	-	
5067-08	NUT FOR FIXING PLATE	M12	-	-	-	DIN-934-CL.8(Dacromet)	32	-	-	
5067-09	WASHER FIXING PLATE	A13	-	-	-	DIN-125A-ST(Dacromet)	32	-	-	
5067-10	WASHER FIXING PLATE	30	-	-	6	st-37(Galv.)	16	-	-	
5067-11	BOLT FOR CONNECTION FAN RING TO PLENUM	M12	40	-	-	DIN-933-CL.8(Dacromet)	24	-	-	
5067-12	NUT	M12	-	-	-	DIN-934-CL.8(Dacromet)	24	-	-	
5067-13	WASHER	A13	-	-	-	DIN-125A-ST(Dacromet)	48	-	-	

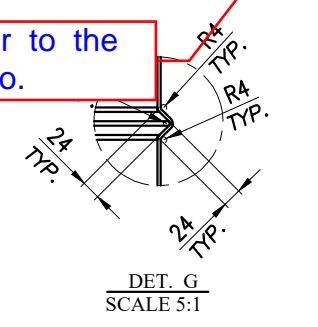
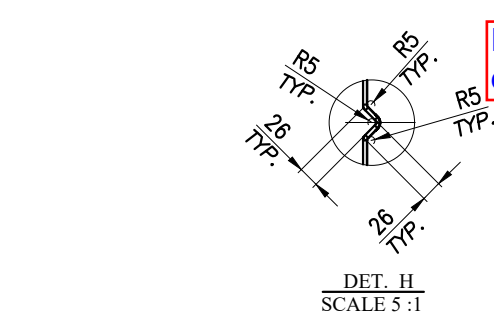
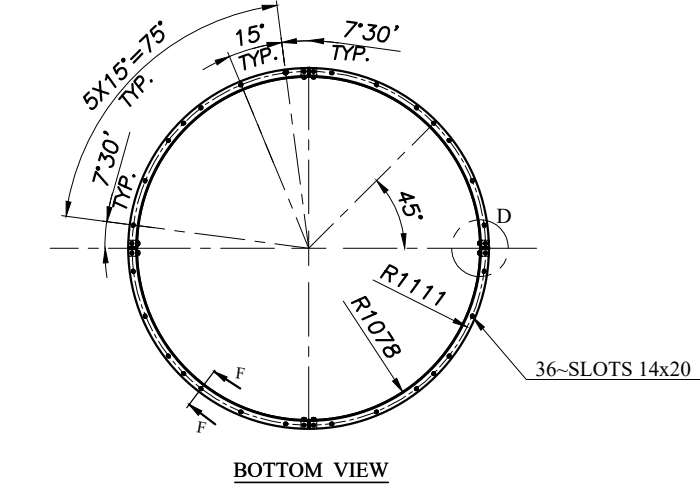
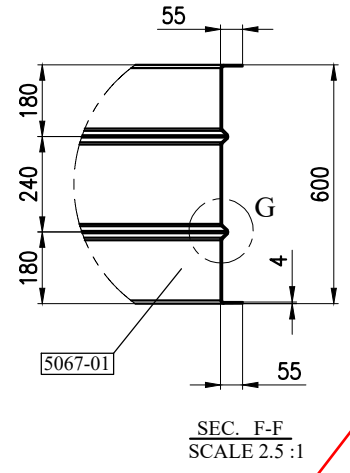
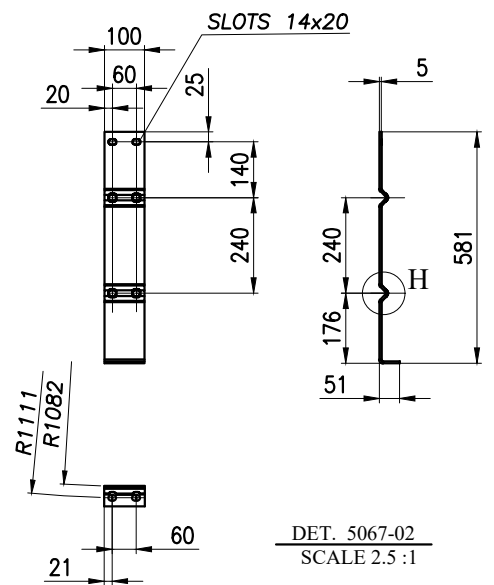
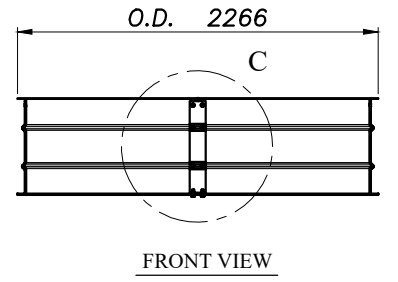
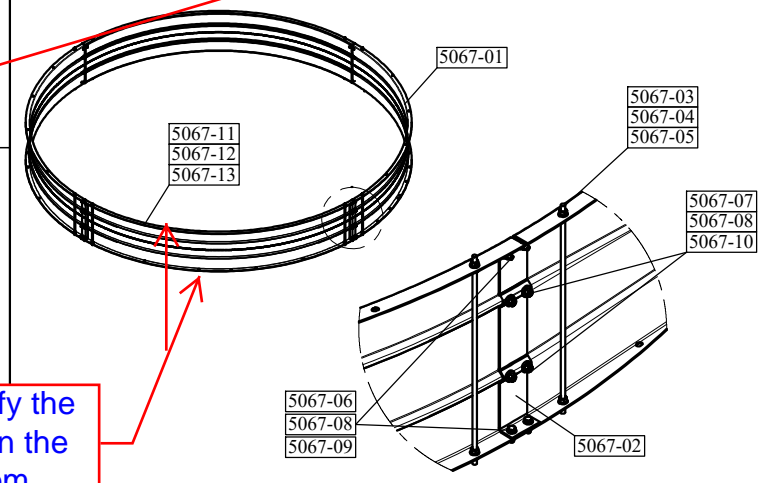
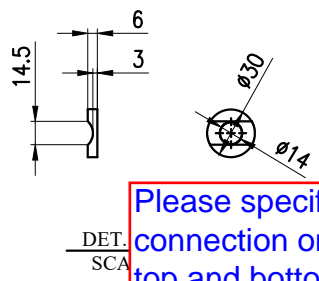
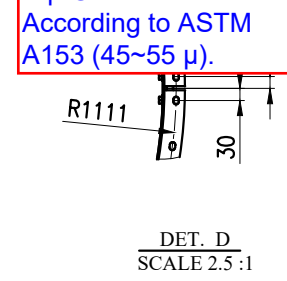
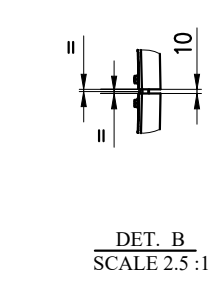
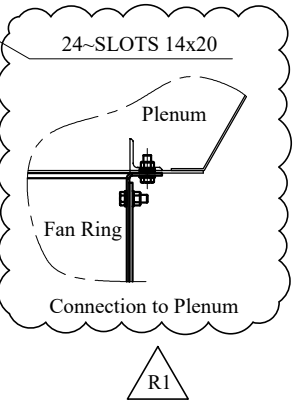
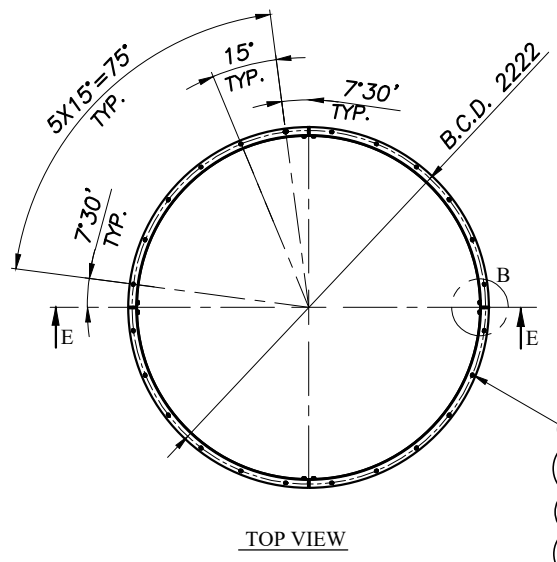
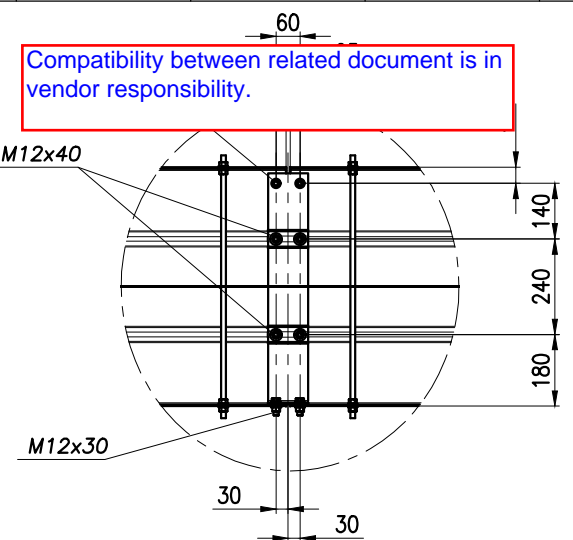
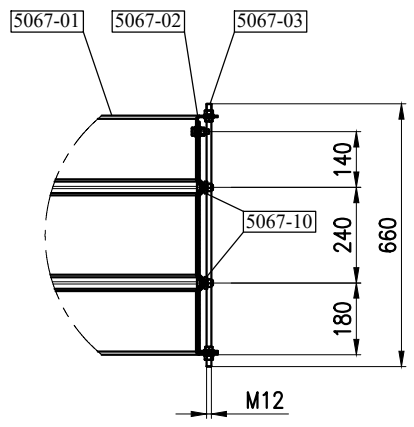
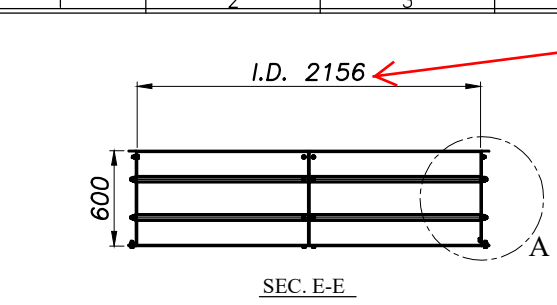

* FOR MORE DETAILS FOR EACH COMPONENT OF AIR COOLER REFER TO BELOW DRAWING & DOCUMENTS.

REFERENCED DWG&DOC.

TITLE	VENDOR DOCUMENT NO.	CLIENT DOCUMENT NO.
General Arrangement Drawing	1158-A01-1000-00	EI027-DMF-VD-ME-DWG-003
Fan Drive Assembly Drawing	1158-A01-6000-00	EI027-DMF-VD-ME-DWG-008
Plenum Drawing	1158-A01-5110-00	EI027-DMF-VD-ME-DWG-011
Support Mechanism Drawing	1158-A01-6307-00	EI027-DMF-VD-ME-DWG-010
Axial Fan Data Sheet	1158-A01-6510-00	EI027-DMF-VD-ME-DSH-016
Surface Preparation and Painting Procedure for Air Cooler	1158-000-QS01-00	EI027-DMF-VD-QC-PRO-024

- NOTES:
- 1-ALL DIMENSION ARE IN MILLIMETERS.
 - 2-BOLTS, NUTS, WASHERS, THREADS, PARTS INCLUDES THREADS SHALL BE AS PER PROJECT SPECIFICATION.
 - 3- ALL PARTS HOT DIP GALVANIZING SHALL BE DONE AS PER ASTM-123/ISO 1461.
 - 4- THIS DRAWING IS COMPATIBLE WITH FAN DATA SHEET DOCUMENT NUMBER EI027-DMF-VD-ME-DSH-016 AND IT SHALL BE READ IN CONJUNCTION WITH RELEVANT DATA SHEET.

GENERAL DATA	
FAN DIA.	2134
FAN RING TYPE	CONICAL L/D=0.05
TIP CLEARANCE	11 mm

TOLERANCES			
THE FOLLOWING VALUES ARE APPLICABLE TO THE DIMENSIONS THAT ARE NOT PROVIDED WITH TOLERANCES ON DRAWING			
NORMAL DIMENSIONS PER MILLIMETER STEPS	0	0.1	0.001
TOLERANCES	± 0.1	± 0.05	± 0.02
TOLERANCE ON OTHER DIMENSIONS THE TOLERANCES SHOWN HERE ARE NOT CUMULATIVE			

REV	DATE	DESCRIPTION	DRAWN BY	CHECKED BY	APPROVED BY	FINAL APPROVED BY
R1	08/20/2024	ISSUED FOR APPROVAL	F.SZ	F.A.	J.B.L	A.GHZ
R0	08/10/2024	ISSUED FOR APPROVAL	F.SZ	F.A.	J.B.L	A.GHZ

CLIENT: **ENBR TEKNOLOJI**

PROJECT: AIR COOLER FOR Toase-eh Park Sanati Gohar Ofogh Petrochemical Co.
Fan Ring & Conical Drawing
1158-A01-5067-00
(Sheet 1 of 2)

DWG. NO. EI027-DMF-VD-ME-DWG-009
SCALE: N.T.S. SIZE: A3 REV: R1

CONTRACTOR: **dt Damafin thermal technology**
Factory: Km 14 special Karaj road

THIS DOCUMENT OF A CONFIDENTIAL NATURE IS THE PROPERTY OF DAMAFIN AND SHALL NOT BE REPRODUCED IN ANY MANNER, NOR USED FOR ANY PURPOSE WHATSOEVER, EXCEPT BY WRITTEN PERMISSION OF DAMAFIN.

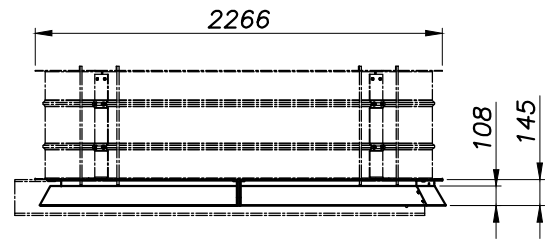

FRONT VIEW

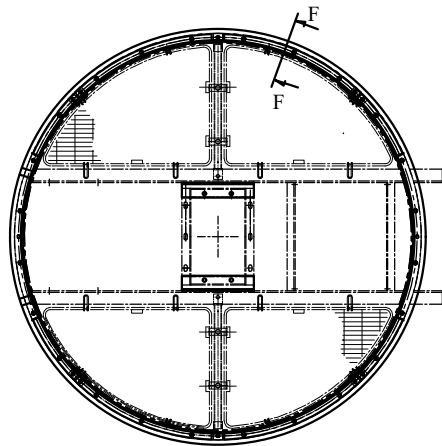

TOP VIEW

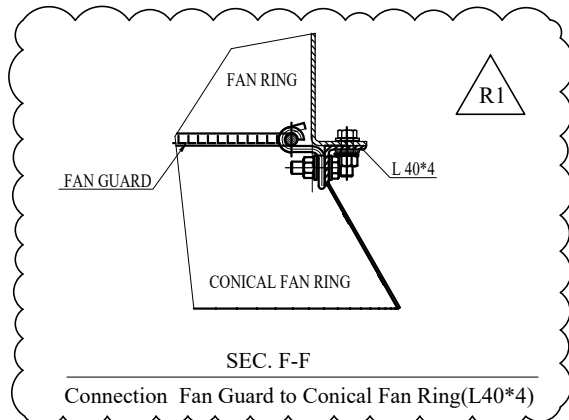

SEC. F-F

Connection Fan Guard to Conical Fan Ring(L40*4)

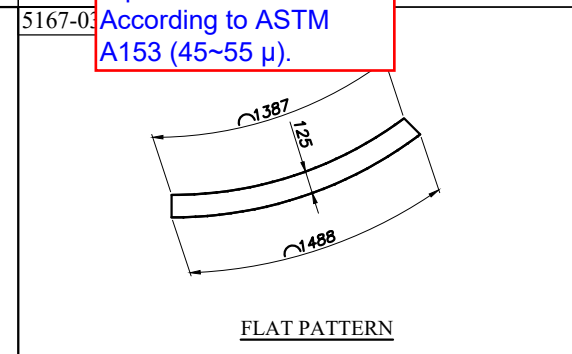
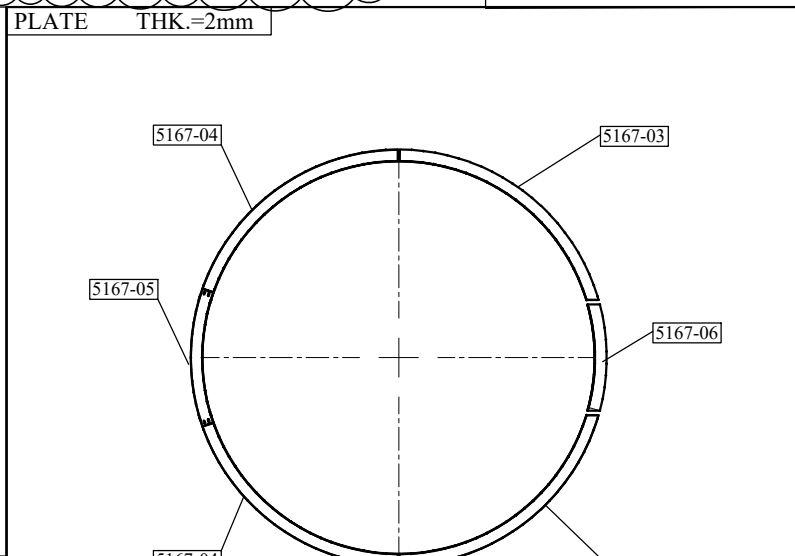
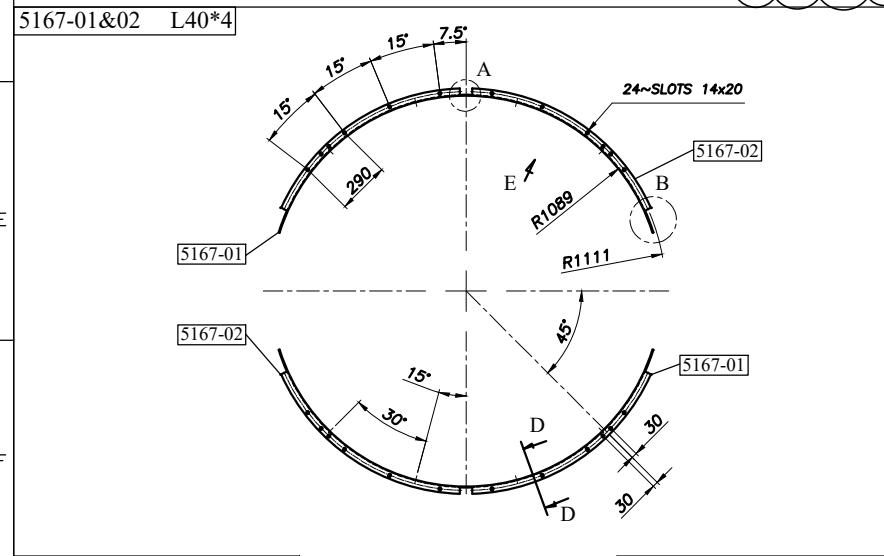
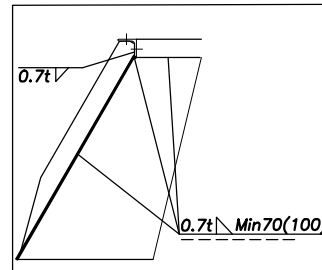

FLAT PATTERN

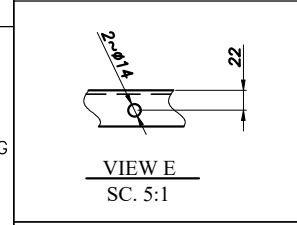

VIEW E
SC. 5:1

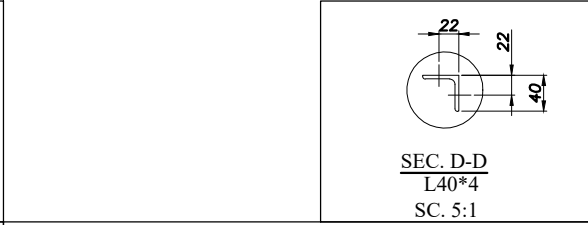

SEC. D-D
L40*4
SC. 5:1

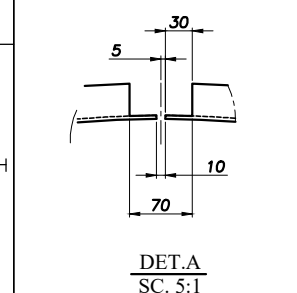

DET.A
SC. 5:1

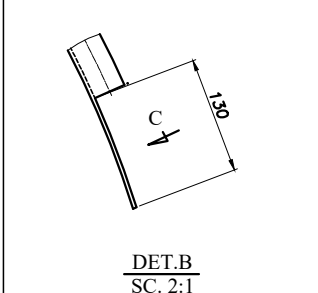

DET.B
SC. 2:1

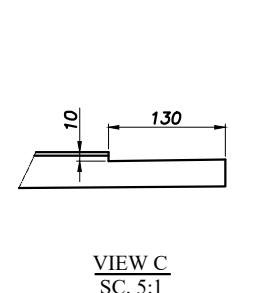

VIEW C
SC. 5:1

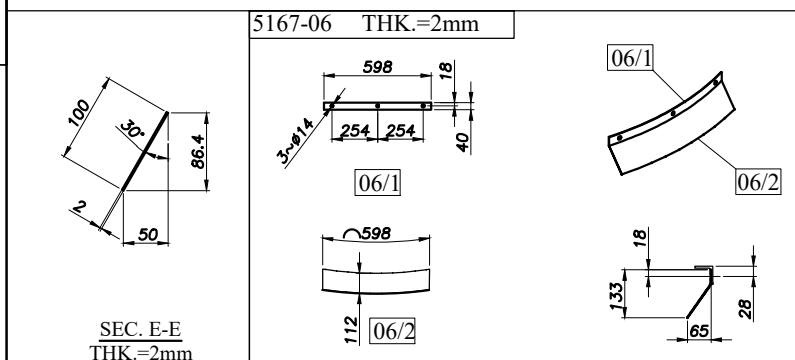

SEC. E-E
THK.=2mm

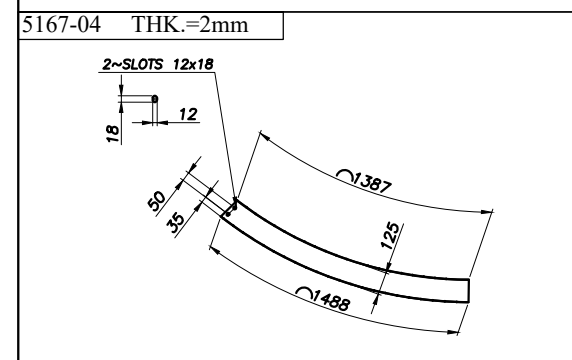
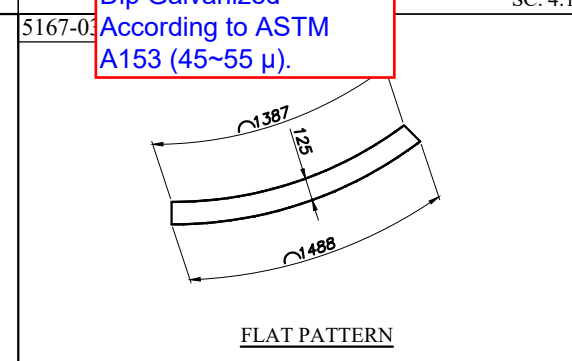
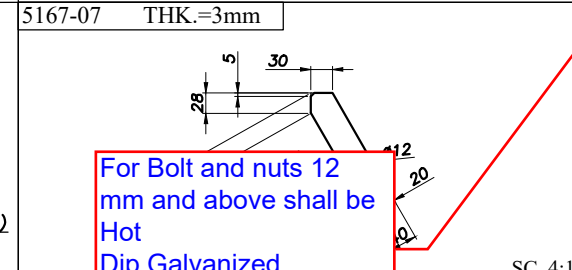
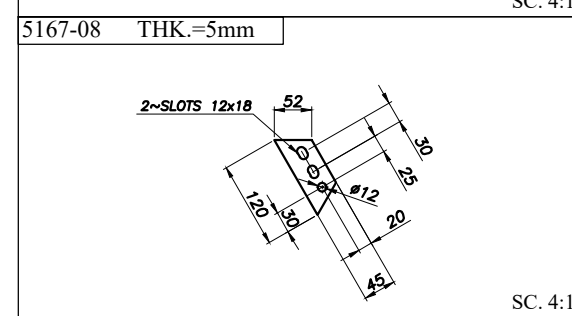
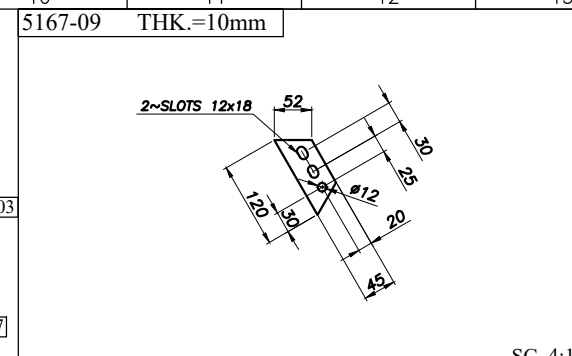
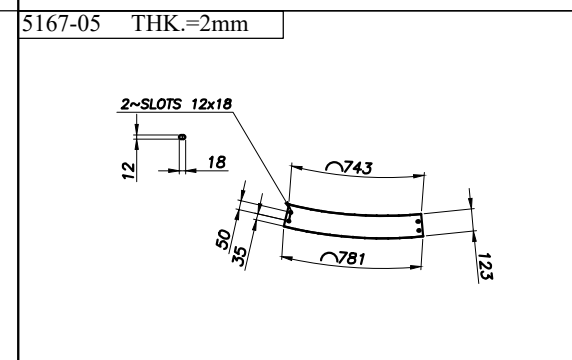
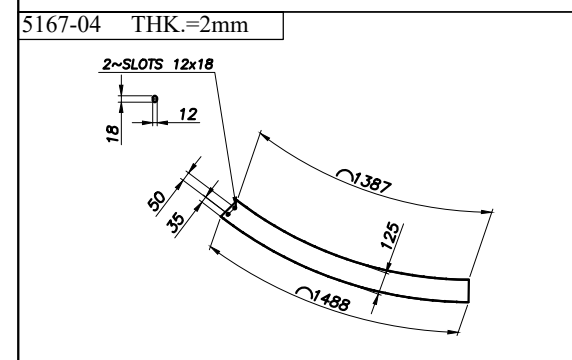

		PART LIST									
PART NO.	DESCRIPTION	DA	LENGTH	WIDTH	THK.	MATERIAL	QTY	Unit Weight	Total Weight	REV.	
5167-08	CONICAL FAN RING FOR ONE SET INCLUDING	-	-	-	-	-	4	29	115		
5167-01	L40*4	-	1300	-	-	St-37(04k)	2	3	6.7		
5167-02	L40*4	-	1300	-	-	St-37(04k)	2	3	6.7		
5167-03	PLATE	-	-	-	2	St-37(04k)	2	2.8	5.6		
5167-04	PLATE	-	-	-	2	St-37(04k)	2	2	4.0		
5167-05	PLATE	-	-	-	2	St-37(04k)	1	1.5	1.5		
5167-000 PLATE ASSEMBLY											
5167-001	PLATE	-	-	-	2	St-37(04k)	1	0.39	0.4		
5167-002	PLATE	-	-	-	2	St-37(04k)	1	1	1.0		
5167-07	PLATE	-	147	40	3	-	6	6.1	1.1		
5167-08	PLATE	-	120	45	5	-	4	6.2	9.8		
5167-09	PLATE	-	120	45	10	DIN 1258-ST(04k)enrM6	2	6.4	9.8		
5167-10	BOLT	M10	30	-	-	DIN 934-CL 8.8(DINenrM6)	6	-	-		
5167-11	NUT	M10	-	-	-	DIN 934-CL 8.8(DINenrM6)	6	-	-		
5167-12	WASHER	A11	-	-	-	DIN 1258-ST(04k)enrM6	18	-	-		
5167-13	BOLT FOR CONNECTING TO SUPPORT MECHANISM	M12	30	-	-	DIN 934-CL 8.8(DINenrM6)	3	-	-		
5167-14	NUT	M12	-	-	-	DIN 934-CL 8.8(DINenrM6)	3	-	-		
5167-15	WASHER	A13	-	-	-	DIN 1258-ST(04k)enrM6	6	-	-		
5167-16	BOLT FOR CONNECTING TO FAN RING	M12	40	-	-	DIN 934-CL 8.8(DINenrM6)	24	-	-		
5167-17	NUT	M12	-	-	-	DIN 934-CL 8.8(DINenrM6)	24	-	-		
5167-18	WASHER	A13	-	-	-	DIN 1258-ST(04k)enrM6	48	-	-		

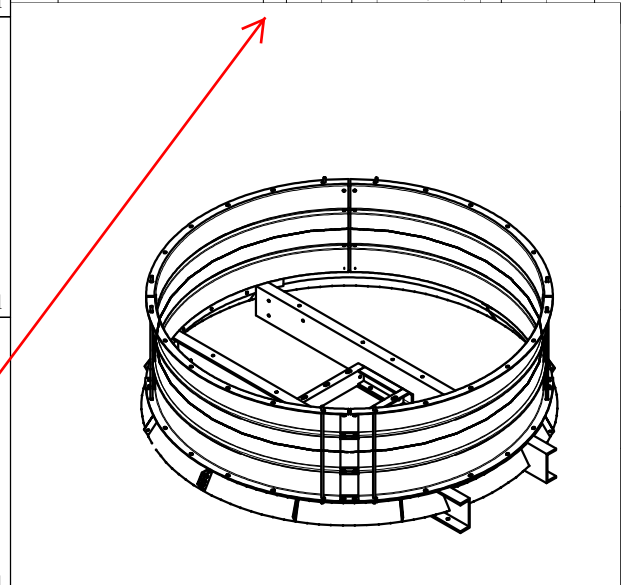

For Bolt and nuts 12 mm and above shall be Hot Dip Galvanized According to ASTM A153 (45~55 μ).

REV	DATE	DESCRIPTION	DRAWN BY	CHECKED BY	APPROVED BY	FINAL APPROVED BY
R1	08/20/2024	ISSUED FOR APPROVAL	F.SZ	F.A.	J.B.L	A.GHZ
R0	08/10/2024	ISSUED FOR APPROVAL	F.SZ	F.A.	J.B.L	A.GHZ

CLIENT: **ENBR TEKNOLOJİ**

PROJECT: AIR COOLER FOR Toase-che Park Sanati Gohar Ofogh Petrochemical Co.
Fan Ring & Conical Drawing
1158-A01-5167-00
(Sheet 2 of 2)

DWG. NO. E1027-DMF-VD-ME-DWG-009
SCALE: N.T.S. SIZE: A3 REV.: R1

CONTRACTOR: **dt Damafin thermal technology**
Factory: Km 14 special Karaj road

THIS DOCUMENT A CONFIDENTIAL NATURE IS THE PROPERTY OF DAMAFIN AND SHALL NOT BE REPRODUCED IN ANY MANNER, NOR USED FOR ANY PURPOSE WHATSOEVER, EXCEPT BY WRITTEN PERMISSION OF DAMAFIN.