



Toase-ehe Park Sanati Gohar Ofogh  
Petrochemical Co.  
**CONCEPTUAL, BASIC and DETAIL DESIGN  
ENGINEERING OF STYRENE PARK OFFSITE**



**dt** Damafin  
thermal technology

Document Title: Mechanical Calculation

Document No.: EI027-DMF-VD-ME-CAL-006

Rev. R3

Page 1 of 132

Please set hydro test pressure : $1.3 * Pd = 28.6$  and do the related calculation in this document according to it.  
( Hydrotest pressure in tube bundle detail drawing is  $1.3 * Pd = 28.6$  too.)

## STYRENE PARK OFFSITE

**Document Title:**  
**Mechanical Calculation**

R3	28-07-2024	IFA	S.SOLGI	J.BEIGLOU	A.GHOLIZADEH
R2	20-07-2024	IFA	S.SOLGI	J.BEIGLOU	A.GHOLIZADEH
R1	01-07-2024	IFA	S.SOLGI	J.BEIGLOU	A.GHOLIZADEH
R0	02-06-2024	IFA	S.SOLGI	J.BEIGLOU	A.GHOLIZADEH
<b>Rev.</b>	<b>Issued Date</b>	<b>DESCRIPTION</b>	<b>PREPARED</b>	<b>CHECKED</b>	<b>APPROVED</b>



Toase-che Park Sanati Gohar Ofogh  
Petrochemical Co.  
**CONCEPTUAL, BASIC and DETAIL DESIGN  
ENGINEERING OF STYRENE PARK OFFSITE**



Document Title: Mechanical Calculation

Document No.: EI027-DMF-VD-ME-CAL-006





Rev. R3

Page 2 of 132

**REVISION RECORD SHEET**

Page Page	Revisions							Page	Revisions						
	R0	R1	R2	R3	R4	R5	R6		R0	R1	R2	R3	R4	R5	R6
1	X							41	X						
2	X			X				42	X						
3	X		X	X				43	X						
4	X	X		X				44	X						
5	X			X				45	X						
6	X			X				46	X						
7	X			X				47	X						
8	X		X	X				48	X						
9	X			X				49	X						
10	X			X				50	X						
11	X			X				51	X						
12	X			X				52	X						
13	X			X				53	X						
14	X			X				54	X						
15	X			X				55	X						
16	X			X				56	X						
17	X			X				57		X					
18	X			X				58		X					
19	X	X	X	X				59		X					
20	X							60		X					
21	X							61		X					
22	X							62		X					
23	X							63		X					
24	X							64		X					
25	X							65		X					
26	X							66		X					
27	X							67		X	X	X			
28	X		X					68		X		X			
29	X							69		X		X			
30	X							70		X		X			
31	X							71		X		X			
32	X							72		X		X			
33	X							73		X		X			
34	X							74		X		X			
35	X							75		X		X			
36	X							76		X	X	X			
37	X							77		X		X			
38	X							78		X		X			
39	X							79		X		X			
40	X							80		X		X			



 	<p>Toase-eh Park Sanati Gohar Ofogh Petrochemical Co.</p> <p><b>CONCEPTUAL, BASIC and DETAIL DESIGN ENGINEERING OF STYRENE PARK OFFSITE</b></p>	 
	Document Title: Mechanical Calculation	
	Document No.: EI027-DMF-VD-ME-CAL-006	Rev. R3

## TABLE OF CONTENTS

Section	Contents	Page No.
<b>1</b>	<b>Mechanical Calculation for</b>	
1-1	Header Under Internal Pressure (Front)	5
1-2	Header Under Internal Pressure (Rear)	9
1-3	Tube Under Internal Pressure	13
1-4	Nozzle Under Internal Pressure (Inlet 4")	14
1-5	Nozzle Under Internal Pressure (Outlet 2")	15
1-6	External Loads on Nozzle (Inlet 4")	16
1-7	External Loads on Nozzle (Outlet 2")	18
1-8	Calculation by PV Elite / CodeCalc	20
1-9	Nozzle N1 FE Analysis by NozzlePro (FE661)	38
1-10	Nozzle N2 FE Analysis by NozzlePro (FE661)	52
<b>2</b>	<b>Stationary &amp; rear header Box code calc in Hydrotest</b>	<b>67</b>
<b>3</b>	<b>Stationary &amp; rear header Box code calc in FV</b>	<b>86</b>
<b>4</b>	<b>TUBE BUCKLING</b>	<b>121</b>
<b>5</b>	<b>calculate Tube to Tube sheet joint as per UW-20.</b>	<b>126</b>
<b>6</b>	<b>pv file for thk calc for tube</b>	<b>127</b>
<b>7</b>	<b>MAWP Summary</b>	<b>131</b>
<b>8</b>	<b>MDMT Summary</b>	<b>132</b>

	<b>JOB N°: 1158</b>	<b>REV.03</b> →	Rev	Date	Issued by	Approved by
	<b>ITEM : A</b>		03	28.jul.2024	S.SOLGI	A.GHOLIZADEH

## VESSEL UNDER INTERNAL PRESSURE

PAGE 2

**PLUG HEADER** (Fig. 13-2(a) Sketch (8)) **FRONT HEADER(DESIGN)**

Code ASME VIII Div. 1 Ed. 1995 Add. 95

Appendix 13 : 13-9 (c)

### DESIGN CONDITIONS

Internal design pressure	P = 2.200 Mpa
Design temperature	θ = 120.0 °C
Corrosion allowance	c = 3.00 mm
Header Material	SA-516-GR70N
Maximum allowable stress value at design temperature	S = 138.0 Mpa
Maximum allowable stress (Membrane + bending)	1.5 S = 207.0 Mpa
Actual inside total height of end plate header	h <sub>αt</sub> = 349.00 mm
Actual inside height of the greatest compartment	h <sub>o</sub> = 140.00 mm
Actual inside width of header	H <sub>o</sub> = 100.00 mm
Thickness of top and bottom plates	t <sub>01</sub> = 20.00 mm
Thickness of plug and tubesheet	t <sub>02</sub> = 20.00 mm
Thickness of partition or stiffener	t <sub>03</sub> = 12.000 mm
Thickness of end plates	t <sub>05</sub> = 20.000 mm
Plug hole diameter	d <sub>e</sub> = 28.600 mm
Horizontal pitch of tubes	P <sub>h</sub> = 69.850 mm
Ligament efficiency E <sub>i</sub> = (p <sub>h</sub> - d <sub>e</sub> ) / p <sub>h</sub>	E <sub>i</sub> = 0.591
Weld joint efficiency	E <sub>w</sub> = 0.850
Ligament efficiency of stiffener	E <sub>s</sub> = 0.600

### CORRODED DIMENSIONS

$$\begin{aligned}
 H &= H_o + 2 \cdot c = 106.00 \text{ mm} & c_1 &= \frac{t_1}{2} = 8.50 \text{ mm} \\
 h &= h_o + 2 \cdot c = 146.00 \text{ mm} \\
 h_t &= h_{\alpha t} + 2 \cdot c = 355.00 \text{ mm} & c_2 &= \frac{t_2}{2} = 8.50 \text{ mm} \\
 t_1 &= t_{01} - c = 17.00 \text{ mm} & t_3 &= t_{03} - 2 \cdot c = 6.00 \text{ mm} \\
 t_2 &= t_{02} - c = 17.00 \text{ mm} & t_5 &= t_{05} - c = 17.00 \text{ mm}
 \end{aligned}$$

### MOMENT OF INERTIA OF STRIP OF THICKNESS

$$\begin{aligned}
 I_1 &= \frac{t_1^3}{12} = 409.4 \text{ mm}^4 \\
 I_2 &= \frac{t_2^3}{12} = 409.4 \text{ mm}^4
 \end{aligned}$$

### VESSEL PARAMETER

$$\begin{aligned}
 \alpha &= \frac{H}{h} = 0.7260 \\
 K &= \frac{I_2}{I_1} \alpha = 0.7260
 \end{aligned}$$

 <p><b>Damafin Thermal Technology Co.</b></p>	<p><b>JOB N°: 1158</b></p> <p><b>ITEM : A</b></p>	<p>Rev 03</p>	<p>Date 28.jul.2024</p>	<p>Issued by S.SOLGI</p>	<p>Approved by A.GHOLIZADEH</p>
---	---	-------------------	-----------------------------	------------------------------	-------------------------------------

## VESSEL UNDER INTERNAL PRESSURE

PAGE 3

### STRESS CALCULATION

#### Top and bottom plates

Membrane stress

$$(13) S_m = \frac{P \cdot h}{2 \cdot t_1 \cdot E_w} \left[ 3 - \left[ \frac{6 + K(11 - \alpha^2)}{3 + 5 \cdot K} \right] \right] \quad S_m = 10.5 \text{ Mpa}$$

$$S_m < S \quad \text{Design OK}$$

Bending stress

$$(16) (S_b)_N = \frac{P \cdot c_1}{24 \cdot I_1} \left[ -3 \cdot H^2 + 2 \cdot h^2 \frac{(3 + 5 \cdot \alpha^2 \cdot K)}{3 + 5 \cdot K} \right] \quad (S_b)_N = 4.0 \text{ Mpa}$$

$$(17) (S_b)_Q = \frac{P \cdot h^2 \cdot c_1}{12 \cdot I_1 \cdot E_w} \left[ \frac{(3 + 5 \cdot \alpha^2 \cdot K)}{3 + 5 \cdot K} \right] \quad (S_b)_Q = 70.7 \text{ Mpa}$$

Total stress

$$(20) (S_T)_N = \text{Eq. (13)} + \text{Eq. (16)} \quad (S_T)_N = 14.6 \text{ Mpa}$$

$$(S_T)_N < 1.5 S \quad \text{Design OK}$$

$$(21) (S_T)_Q = \text{Eq. (13)} + \text{Eq. (17)} \quad (S_T)_Q = 81.3 \text{ Mpa}$$

$$(S_T)_Q < 1.5 S \quad \text{Design OK}$$

 <p><b>Damafin Thermal Technology Co.</b></p>	<p><b>JOB N°: 1158</b></p> <p><b>ITEM : A</b></p>	<p>Rev 03</p>	<p>Date 28.jul.2024</p>	<p>Issued by S.SOLGI</p>	<p>Approved by A.GHOLIZADEH</p>
---	---	-------------------	-----------------------------	------------------------------	-------------------------------------

**VESSEL UNDER INTERNAL PRESSURE**

**PAGE 4**

STRESS CALCULATION

Plug and tubesheet

Membrane stress

$$(14) S_m = \frac{P \cdot H}{2 \cdot t_2 \cdot E_1}$$

$$S_m = 11.6 \text{ Mpa}$$

$$S_m < S \text{ Design OK}$$

Bending stress

$$(18) (S_b)_M = \frac{P \cdot h^2 \cdot c_2}{12 \cdot I_2} \left[ \frac{(3 + K(6 - \alpha^2))}{3 + 5 \cdot K} \right]$$

$$(S_b)_M = 85.3 \text{ Mpa}$$

$$(19) (S_b)_Q = \frac{P \cdot h^2 \cdot c_2}{12 \cdot I_2} \left[ \frac{(3 + 5 \cdot \alpha^2 \cdot K)}{3 + 5 \cdot K} \right]$$

$$(S_b)_Q = 60.1 \text{ Mpa}$$

Total stress

$$(22) (S_T)_M = \text{Eq. (14)} + \text{Eq. (18)}$$

$$(S_T)_M = 97.0 \text{ Mpa}$$

$$(S_T)_M < 1.5 S \text{ Design OK}$$

$$(23) (S_T)_Q = \text{Eq. (14)} + \text{Eq. (19)}$$

$$(S_T)_Q = 71.7 \text{ Mpa}$$

$$(S_T)_Q < 1.5 S \text{ Design OK}$$

 <p><b>Damafin Thermal Technology Co.</b></p>	<p><b>JOB N°: 1158</b></p> <p><b>ITEM : A</b></p>	<p>Rev 03</p>	<p>Date 28.jul.2024</p>	<p>Issued by S.SOLGI</p>	<p>Approved by A.GHOLIZADEH</p>
---	---	-------------------	-----------------------------	------------------------------	-------------------------------------

**VESSEL UNDER INTERNAL PRESSURE**

**PAGE 5**

STRESS CALCULATION

Partition plate or stiffener

Membrane stress

$$E = \min ( 0.6 , E_s ) = 0.6000$$

$$(15) S_m = \frac{P \cdot h}{2 \cdot t_3 \cdot E} \left[ \frac{6 + K ( 11 - \alpha^2 )}{3 + 5 \cdot K} \right] \quad S_m = 91.5 \text{ Mpa}$$

$$S_m < S \quad \text{Design OK}$$

End Plate      UG-34 (c) (3)

For operating conditions

$$d = \min ( h_t , H ) \quad d = 106.00 \text{ mm}$$

$$D = \max ( h_t , H ) \quad D = 355.00 \text{ mm}$$

$$C = 0.20$$

$$Z = 3.4 - \frac{2.4 \cdot d}{D} = 2.683$$

$$Z = \min ( Z , 2.5 ) = 2.500$$

$$t_{0.5} = d \sqrt{\frac{Z \cdot C \cdot P}{S \cdot E_w}} + c = 13.28 \text{ mm}$$

$$\text{Used thickness : } t_{0.5} = 13.28 \text{ mm}$$

	<b>JOB N°: 1158</b>	Rev 03	Date 28.jul.2024	Issued by S.SOLGI	Approved by A.GHOLIZADEH
	<b>ITEM : A</b>				

## VESSEL UNDER INTERNAL PRESSURE

PAGE 6

**PLUG HEADER** (Fig. 13-2(a) Sketch (7)) **REAR HEADER (DESIGN)**

Code ASME VIII Div. 1 Ed. 1995 Add. 95

Appendix 13 : 13-9 (b)

### DESIGN CONDITIONS

Internal design pressure	P = 2.200 Mpa
Design temperature	θ = 120.0 °C
Corrosion allowance	c = 3.00 mm
Header Material	SA-516-GR70N
Maximum allowable stress value at design temperature	S = 138.0 Mpa
Maximum allowable stress (Membrane + bending)	1.5 S = 207.0 Mpa
Actual inside total height of end plate header	h <sub>αt</sub> = 288.00 mm
Actual inside height of the greatest compartment	h <sub>o</sub> = 138.00 mm
Actual inside width of header	H <sub>o</sub> = 100.00 mm
Thickness of top and bottom plates	t <sub>01</sub> = 20.00 mm
Thickness of plug and tubesheet	t <sub>02</sub> = 20.00 mm
Thickness of partition or stiffener	t <sub>03</sub> = 12.000 mm
Thickness of end plates	t <sub>05</sub> = 20.000 mm
Plug hole diameter	d <sub>e</sub> = 28.600 mm
Horizontal pitch of tubes	P <sub>h</sub> = 69.850 mm
Ligament efficiency E <sub>i</sub> = (p <sub>h</sub> - d <sub>e</sub> ) / p <sub>h</sub>	E <sub>i</sub> = 0.591
Weld joint efficiency	E <sub>w</sub> = 0.850
Ligament efficiency of stiffener	E <sub>s</sub> = 0.600

### CORRODED DIMENSIONS

$$\begin{aligned}
 H &= H_o + 2 \cdot c = 106.00 \text{ mm} & c_1 &= \frac{t_1}{2} = 8.50 \text{ mm} \\
 h &= h_o + 2 \cdot c = 144.00 \text{ mm} \\
 h_t &= h_{\alpha t} + 2 \cdot c = 294.00 \text{ mm} & c_2 &= \frac{t_2}{2} = 8.50 \text{ mm} \\
 t_1 &= t_{01} - c = 17.00 \text{ mm} & t_3 &= t_{03} - 2 \cdot c = 6.00 \text{ mm} \\
 t_2 &= t_{02} - c = 17.00 \text{ mm} & t_5 &= t_{05} - c = 17.00 \text{ mm}
 \end{aligned}$$

### MOMENT OF INERTIA OF STRIP OF THICKNESS

$$\begin{aligned}
 I_1 &= \frac{t_1^3}{12} = 409.4 \text{ mm}^4 \\
 I_2 &= \frac{t_2^3}{12} = 409.4 \text{ mm}^4
 \end{aligned}$$

### VESSEL PARAMETER

$$\begin{aligned}
 \alpha &= \frac{H}{h} = 0.7361 \\
 K &= \frac{I_2}{I_1} \alpha = 0.7361
 \end{aligned}$$

 <p><b>Damafin Thermal Technology Co.</b></p>	<p><b>JOB N°: 1158</b></p> <p><b>ITEM : A</b></p>	<p>Rev 03</p>	<p>Date 28.jul.2024</p>	<p>Issued by S.SOLGI</p>	<p>Approved by A.GHOLIZADEH</p>
---	---	-------------------	-----------------------------	------------------------------	-------------------------------------

## VESSEL UNDER INTERNAL PRESSURE

PAGE 7

### STRESS CALCULATION

#### Top and bottom plates

Membrane stress

$$(1) S_m = \frac{P \cdot h}{4 \cdot t_1 \cdot E_w} \left[ 4 - \left[ \frac{2 + K(5 - \alpha^2)}{1 + 2 \cdot K} \right] \right] \quad S_m = 10.2 \text{ Mpa}$$

$S_m < S$  Design OK

Bending stress

$$(4) (S_b)_N = \frac{P \cdot c_1}{24 \cdot I_1} \left[ -3 \cdot H^2 + 2 \cdot h^2 \frac{(1 + 2 \cdot \alpha^2 \cdot K)}{1 + 2 \cdot K} \right] \quad (S_b)_N = 6.8 \text{ Mpa}$$

$$(5) (S_b)_Q = \frac{P \cdot h^2 \cdot c_1}{12 \cdot I_1 \cdot E_w} \left[ \frac{(1 + 2 \cdot \alpha^2 \cdot K)}{1 + 2 \cdot K} \right] \quad (S_b)_Q = 67.5 \text{ Mpa}$$

Total stress

$$(8) (S_T)_N = \text{Eq. (1)} + \text{Eq. (4)} \quad (S_T)_N = 17.0 \text{ Mpa}$$

$(S_T)_N < 1.5 S$  Design OK

$$(8) (S_T)_Q = \text{Eq. (1)} + \text{Eq. (5)} \quad (S_T)_Q = 77.7 \text{ Mpa}$$

$(S_T)_Q < 1.5 S$  Design OK

 <p><b>Damafin Thermal Technology Co.</b></p>	<p><b>JOB N°: 1158</b></p> <p><b>ITEM : A</b></p>	<p>Rev 03</p>	<p>Date 28.jul.2024</p>	<p>Issued by S.SOLGI</p>	<p>Approved by A.GHOLIZADEH</p>
---	---	-------------------	-----------------------------	------------------------------	-------------------------------------

## VESSEL UNDER INTERNAL PRESSURE

PAGE 8

### STRESS CALCULATION

#### Plug and tubesheet

#### Membrane stress

$$(2) S_m = \frac{P \cdot H}{2 \cdot t_2 \cdot E_t}$$

$$S_m = 11.6 \text{ Mpa}$$

$$S_m < S \text{ Design OK}$$

#### Bending stress

$$(6) (S_b)_M = \frac{P \cdot h^2 \cdot c_2}{12 \cdot I_2} \left[ \frac{(1 + K(3 - \alpha^2))}{1 + 2 \cdot K} \right]$$

$$(S_b)_M = 89.7 \text{ Mpa}$$

$$(7) (S_b)_Q = \frac{P \cdot h^2 \cdot c_2}{12 \cdot I_2} \left[ \frac{(1 + 2 \cdot \alpha^2 \cdot K)}{1 + 2 \cdot K} \right]$$

$$(S_b)_Q = 57.4 \text{ Mpa}$$

#### Total stress

$$(10) (S_T)_M = \text{Eq. (2)} + \text{Eq. (6)}$$

$$(S_T)_M = 101.3 \text{ Mpa}$$

$$(S_T)_M < 1.5 S \text{ Design OK}$$

$$(11) (S_T)_Q = \text{Eq. (2)} + \text{Eq. (7)}$$

$$(S_T)_Q = 69.0 \text{ Mpa}$$

$$(S_T)_Q < 1.5 S \text{ Design OK}$$

	<b>JOB N°: 1158</b>  <b>ITEM : A</b>	Rev 03	Date 28.jul.2024	Issued by S.SOLGI	Approved by A.GHOLIZADEH
--	--	-----------	---------------------	----------------------	-----------------------------

## VESSEL UNDER INTERNAL PRESSURE

PAGE 9

### STRESS CALCULATION

Partition plate or stiffener

Membrane stress

$$E = \min ( 0.6 , E_s ) = 0.6000$$

$$(3) S_m = \frac{P \cdot h}{2 \cdot t_3 \cdot E} \left[ \frac{2 + K ( 5 - \alpha^2 )}{1 + 2 \cdot K} \right] \quad S_m = 94.0 \text{ Mpa}$$

$$S_m < S \quad \text{Design OK}$$

End Plate      UG-34 (c) (3)

For operating conditions

$$d = \min ( h_t , H ) \quad d = 106.00 \text{ mm}$$

$$D = \max ( h_t , H ) \quad D = 294.00 \text{ mm}$$

$$C = 0.20$$

$$Z = 3.4 \cdot \frac{2.4 \cdot d}{D} = 2.535 \quad Z = \min ( Z , 2.5 ) = 2.500$$

$$t_{0.5} = d \sqrt{\frac{Z \cdot C \cdot P}{S \cdot E_w}} + c = 13.28 \text{ mm}$$

$$\text{Used thickness : } t_{0.5} = 13.28 \text{ mm}$$

 <p><b>Damafin Thermal Technology Co.</b></p>	<p><b>JOB N°: 1158</b></p> <p><b>ITEM : A</b></p>	<p>Rev 03</p>	<p>Date 28.jul.2024</p>	<p>Issued by S.SOLGI</p>	<p>Approved by A.GHOLIZADEH</p>
---	---	-------------------	-----------------------------	------------------------------	-------------------------------------

**VESSEL UNDER INTERNAL PRESSURE**

**PAGE 10**

**TUBE 1"**

Code ASME VIII Div. 1 Ed. 1995 Add. 95

Appendix 1 : 1-1

DESIGN CONDITIONS

Internal design pressure	P = 2.200 Mpa
Design temperature	θ = 120.0 °C
Material SA-334-6	
Maximum allowable stress value	S = 118.0 Mpa
Outside diameter	d <sub>o</sub> = 25.40 mm
Corrosion allowance	c = 0.00 mm
Joint efficiency	E = 1.000

MINIMUM REQUIRED THICKNESS

$$P < 0.385 \cdot S$$

$$t = \frac{P \cdot d_o}{2 (S \cdot E + 0.4 \cdot P)} + c = 0.24 \text{ mm}$$

Used thickness: t = 1.65 mm

MAXIMUM ALLOWABLE WORKING PRESSURE

$$P_a = \frac{2 \cdot S \cdot E (t - c)}{(d_o - 0.8 (t - c))} = 16.171 \text{ Mpa}$$

SERVICE STRESS

$$S_m = \frac{P \cdot (d_o - 0.8 (t - c))}{2 \cdot E (t - c)} = 16.1 \text{ Mpa}$$

 <b>Damafin Thermal Technology Co.</b>	<b>JOB N°: 1158</b>	Rev 03	Date 28.jul.2024	Issued by S.SOLGI	Approved by A.GHOLIZADEH
	<b>ITEM : A</b>				

## VESSEL UNDER INTERNAL PRESSURE

PAGE 11

**NOZZLE** INLET 4"

Code ASME VIII Div. 1 Ed. 1995 Add. 95

Appendix 1 : 1-1

### DESIGN CONDITIONS

Internal design pressure	P = 2.200 Mpa
Design temperature	θ = 120.0 °C
Material SA 333 GR 6	
Maximum allowable stress value	S = 118.0 Mpa
Outside diameter	d <sub>0</sub> = 114.00 mm
Corrosion allowance	c = 3.00 mm
Mill undertolerance	c <sub>1</sub> = 1.70 mm
Joint efficiency	E = 1.000

### MINIMUM REQUIRED THICKNESS

$$P < 0.385 \cdot S$$

$$t = \frac{P \cdot d_0}{2(S \cdot E + 0.4 \cdot P)} + c + c_1 = 5.75 \text{ mm}$$

Used thickness:  $t_n = 13.50 \text{ mm}$

$$R = \frac{d_0}{2} - t_n + c + c_1 = 48.20 \text{ mm} \quad t_n - c - c_1 < \frac{R}{2} \quad \text{design OK}$$

### MAXIMUM ALLOWABLE WORKING PRESSURE

$$P_a = \frac{2 \cdot S \cdot E (t_n - c - c_1)}{(d_0 - 0.8 (t_n - c - c_1))} = 19.42 \text{ Mpa}$$

### SERVICE STRESS

$$S_m = \frac{P \cdot (d_0 - 0.8 (t_n - c - c_1))}{2 \cdot E (t_n - c - c_1)} = 13.37 \text{ Mpa}$$

 <b>Damafin Thermal Technology Co.</b>	<b>JOB N°: 1158</b>	Rev 03	Date 28.jul.2024	Issued by S.SOLGI	Approved by A.GHOLIZADEH
	<b>ITEM : A</b>				

## VESSEL UNDER INTERNAL PRESSURE

PAGE 12

**FORGED NOZZLE      OUTLET 2"**

Code ASME VIII Div. 1 Ed. 1995 Add. 95

UG-37 (c)

### DESIGN CONDITIONS

Internal design pressure	P = 2.200 Mpa
Design temperature	θ = 120.0 °C
Material                    SA-350 LF2 CLASS 1	
Maximum allowable stress value	S = 138.0 Mpa
Actual inside diameter	d <sub>i</sub> = 50.80 mm
Corrosion allowance	c = 3.00 mm
Machining undertolerance	c <sub>1</sub> = 0.00 mm
Ligament efficiency	E = 1.000

### MINIMUM REQUIRED THICKNESS

$$P < 0.385 \cdot S$$

$$R = \frac{d_i}{2} + c + c_1 = 28.40 \text{ mm}$$

$$t = \frac{P \cdot R}{(S \cdot E - 0.6 \cdot P)} + c + c_1 = 3.46 \text{ mm}$$

Used thickness:  $t_n = 16.60 \text{ mm}$

REV.03

$$t_n - c - c_1 < \frac{R}{2} \quad \text{design OK}$$

### MAXIMUM ALLOWABLE WORKING PRESSURE

$$P_a = \frac{S \cdot E (t_n - c - c_1)}{(R + 0.6 (t_n - c - c_1))} = 51.33 \text{ Mpa}$$

### SERVICE STRESS

$$S_m = \frac{P \cdot (R + 0.6 (t_n - c - c_1))}{E (t_n - c - c_1)} = 5.91 \text{ Mpa}$$

 <b>Damafin Thermal Technology Co.</b>	<b>JOB N°: 1158</b>	Rev 03	Date 28.jul.2024	Issued by S.SOLGI	Approved by A.GHOLIZADEH
	<b>ITEM : A</b>				

## VESSEL UNDER INTERNAL PRESSURE

**PAGE 13**

### EXTERNAL LOADS ON NOZZLE

INLET 4" ,WN ,SCH 160,#300

Code ASME VIII Div. 1 Ed. 1995 Add. 95

U-2(g)

### DESIGN CONDITIONS

Internal design pressure	$P = 2.200 \text{ Mpa}$
Design temperature	$\theta = 120.0 \text{ }^\circ\text{C}$
Nozzle Material SA 333 GR 6	
Maximum allowable stress value	$S_n = 118.0 \text{ Mpa}$
Nozzle outside diameter	$d_o = 114.00 \text{ mm}$
Nozzle thickness	$t_{on} = 13.50 \text{ mm}$
Nozzle mill undertolerance	$c_{n1} = 1.70 \text{ mm}$
Nozzle forging undertolerance	$c_{n2} = 0.00 \text{ mm}$
Corrosion allowance	$c = 3.00 \text{ mm}$
Inside radius of obround cross section	$R_i = 43.50 \text{ mm}$
Length of the side plate of obround cross section	$L = 87.00 \text{ mm}$
Distance from loads application to circular cross section	$a = 7.60 \text{ mm}$
Distance from loads application to obround cross section	$b = 200.00 \text{ mm}$

### APPLIED LOADS

Force in X direction	$F_x = 10020 \text{ N}$
Force in Y direction	$F_y = 8010 \text{ N}$
Force in Z direction	$F_z = 10020 \text{ N}$
Moment in X direction	$M_x = 2430 \text{ m.N}$
Moment in Y direction	$M_y = 3660 \text{ m.N}$
Moment in Z direction	$M_z = 2430 \text{ m.N}$

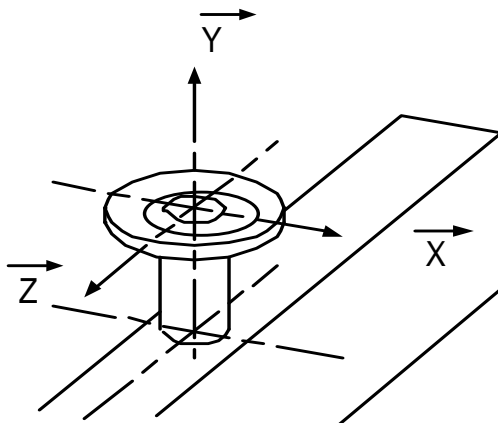

	<b>JOB N°: 1158</b>	Rev 03	Date 28.jul.2024	Issued by S.SOLGI	Approved by A.GHOLIZADEH
	<b>ITEM : A</b>				

## VESSEL UNDER INTERNAL PRESSURE

PAGE 14

### CORRODED SIZES FOR CIRCULAR CROSS SECTION

$$\begin{aligned}
 t_{n1} &= t_{on} - C - C_{n1} = 8.80 \text{ mm} & R_{o1} &= d_o / 2 = 57.00 \text{ mm} \\
 R_{i1} &= R_{o1} - t_{n1} = 48.20 \text{ mm} & R_{m1} &= R_{o1} - t_{n1} / 2 = 52.60 \text{ mm} \\
 \text{Cross section area} & & S_1 &= 2908.36 \text{ mm}^2 \\
 \text{Mean cross section area} & & A_1 &= 8692.03 \text{ mm}^2 \\
 \text{Moment of inertia} & & I_{x1} &= 4051521 \text{ mm}^4 \\
 \text{Moment of inertia} & & I_{z1} &= 4051521 \text{ mm}^4
 \end{aligned}$$

### CORRODED SIZES FOR OBOUND CROSS SECTION

$$\begin{aligned}
 t_{n2} &= t_{on} - C - C_{n1} - C_{n2} = 8.80 \text{ mm} & R_{i2} &= R_i + c = 46.50 \text{ mm} \\
 R_{o2} &= R_{i2} + t_{n2} = 55.30 \text{ mm} & R_{m2} &= R_{i2} + t_{n2} / 2 = 50.90 \text{ mm} \\
 \text{Cross section area} & & S_2 &= 4345.56 \text{ mm}^2 \\
 \text{Mean cross section area} & & A_2 &= 16995.87 \text{ mm}^2 \\
 \text{Moment of inertia} & & I_{x2} &= 17918129 \text{ mm}^4 \\
 \text{Moment of inertia} & & I_{z2} &= 7649914 \text{ mm}^4
 \end{aligned}$$

### CALCULATED STRESSES IN CIRCULAR CROSS SECTION

$$\begin{aligned}
 \text{Maximum principal stresses} & \quad \sigma_1 = 29.6 \text{ Mpa} & \sigma_2 &= 0.0 \text{ Mpa} & \sigma_3 &= -55.5 \text{ Mpa} \\
 \text{Stress intensity} & & & & & \\
 S_{12} &= |\sigma_1 - \sigma_2| = 29.6 \text{ Mpa} & S_{23} &= |\sigma_2 - \sigma_3| = 55.5 \text{ Mpa} & S_{31} &= |\sigma_3 - \sigma_1| = 85.1 \text{ Mpa} \\
 \text{Maximum stress intensity} & \quad S = \max ( S_{12} , S_{23} , S_{31} ) & & & S &= 85.1 \text{ Mpa} \\
 & \quad S < 1.5 \cdot S_n & & & & \text{Design OK}
 \end{aligned}$$

### CALCULATED STRESSES IN OBOUND CROSS SECTION

$$\begin{aligned}
 \text{Maximum principal stresses} & \quad \sigma_1 = 30.1 \text{ Mpa} & \sigma_2 &= 0.0 \text{ Mpa} & \sigma_3 &= -23.4 \text{ Mpa} \\
 \text{Stress intensity} & & & & & \\
 S_{12} &= |\sigma_1 - \sigma_2| = 30.1 \text{ Mpa} & S_{23} &= |\sigma_2 - \sigma_3| = 23.4 \text{ Mpa} & S_{31} &= |\sigma_3 - \sigma_1| = 53.6 \text{ Mpa} \\
 \text{Maximum stress intensity} & \quad S = \max ( S_{12} , S_{23} , S_{31} ) & & & S &= 53.6 \text{ Mpa} \\
 & \quad S < 1.5 \cdot S_n & & & & \text{Design OK}
 \end{aligned}$$

 <b>Damafin Thermal Technology Co.</b>	<b>JOB N°: 1158</b>	<b>REV.03</b>	Rev 03	Date 28.jul.2024	Issued by S.SOLGI	Approved by A.GHOLIZADEH
	<b>ITEM : A</b>					

## VESSEL UNDER INTERNAL PRESSURE

**PAGE 15**

### EXTERNAL LOADS ON NOZZLE

OUTLET 2",LWN,SCH160,#300

Code ASME VIII Div. 1 Ed. 1995 Add. 95

U-2(g)

### DESIGN CONDITIONS

Internal design pressure	$P = 2.200 \text{ Mpa}$
Design temperature	$\theta = 120.0 \text{ }^\circ\text{C}$
Nozzle Material SA 350 LF2 CLASS1	
Maximum allowable stress value	$S_n = 138.0 \text{ Mpa}$
Nozzle outside diameter	<b>REV.03</b> $d_o = 82.50 \text{ mm}$
Nozzle thickness	$t_{on} = 16.60 \text{ mm}$
Nozzle mill undertolerance	$c_{n1} = 0.00 \text{ mm}$
Nozzle forging undertolerance	$c_{n2} = 0.00 \text{ mm}$
Corrosion allowance	$c = 3.00 \text{ mm}$
Inside radius of obround cross section	$R_i = 25.40 \text{ mm}$
Length of the side plate of obround cross section	$L = 50.80 \text{ mm}$
Distance from loads application to circular cross section	$a = 19.10 \text{ mm}$
Distance from loads application to obround cross section	$b = 200.00 \text{ mm}$

### APPLIED LOADS

Force in X direction	$F_x = 3060 \text{ N}$
Force in Y direction	$F_y = 3990 \text{ N}$
Force in Z direction	$F_z = 3060 \text{ N}$
Moment in X direction	$M_x = 450 \text{ m.N}$
Moment in Y direction	$M_y = 720 \text{ m.N}$
Moment in Z direction	$M_z = 450 \text{ m.N}$

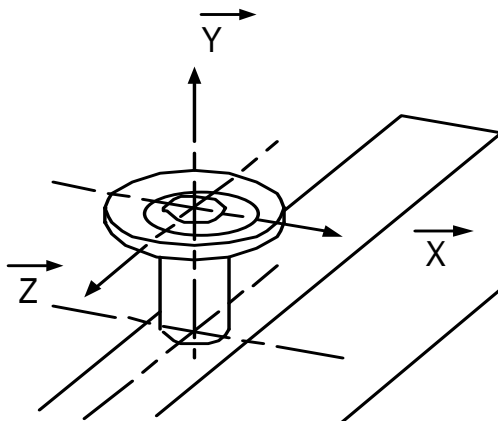

	<b>JOB N°: 1158</b>	Rev 03	Date 28.jul.2024	Issued by S.SOLGI	Approved by A.GHOLIZADEH
	<b>ITEM : A</b>				

## VESSEL UNDER INTERNAL PRESSURE

PAGE 16

### CORRODED SIZES FOR CIRCULAR CROSS SECTION

$$t_{n1} = t_{on} - C - C_{n1} = 13.60 \text{ mm} \quad R_{o1} = d_o / 2 = 41.25 \text{ mm}$$

$$R_{i1} = R_{o1} - t_{n1} = 27.65 \text{ mm} \quad R_{m1} = R_{o1} - t_{n1} / 2 = 34.45 \text{ mm}$$

$$\text{Cross section area} \quad S_1 = 2943.80 \text{ mm}^2$$

$$\text{Mean cross section area} \quad A_1 = 3728.45 \text{ mm}^2$$

$$\text{Moment of inertia} \quad I_{x1} = 1814914 \text{ mm}^4$$

$$\text{Moment of inertia} \quad I_{z1} = 1814914 \text{ mm}^4$$

### CORRODED SIZES FOR OBOUND CROSS SECTION

$$t_{n2} = t_{on} - C - C_{n1} - C_{n2} = 13.60 \text{ mm} \quad R_{i2} = R_i + c = 28.40 \text{ mm}$$

$$R_{o2} = R_{i2} + t_{n2} = 42.00 \text{ mm} \quad R_{m2} = R_{i2} + t_{n2} / 2 = 35.20 \text{ mm}$$

$$\text{Cross section area} \quad S_2 = 4389.65 \text{ mm}^2$$

$$\text{Mean cross section area} \quad A_2 = 7468.88 \text{ mm}^2$$

$$\text{Moment of inertia} \quad I_{x2} = 7637415 \text{ mm}^4$$

$$\text{Moment of inertia} \quad I_{z2} = 3666342 \text{ mm}^4$$

### CALCULATED STRESSES IN CIRCULAR CROSS SECTION

$$\text{Maximum principal stresses} \quad \sigma_1 = 10.3 \text{ Mpa} \quad \sigma_2 = 0.0 \text{ Mpa} \quad \sigma_3 = -15.2 \text{ Mpa}$$

$$\text{Stress intensity}$$

$$S_{12} = |\sigma_1 - \sigma_2| = 10.3 \text{ Mpa} \quad S_{23} = |\sigma_2 - \sigma_3| = 15.2 \text{ Mpa} \quad S_{31} = |\sigma_3 - \sigma_1| = 25.5 \text{ Mpa}$$

$$\text{Maximum stress intensity} \quad S = \max ( S_{12} , S_{23} , S_{31} ) \quad S = 25.5 \text{ Mpa}$$

$$S < 1.5 \cdot S_n \quad \text{Design OK}$$

### CALCULATED STRESSES IN OBOUND CROSS SECTION

$$\text{Maximum principal stresses} \quad \sigma_1 = 10.4 \text{ Mpa} \quad \sigma_2 = 0.0 \text{ Mpa} \quad \sigma_3 = -7.6 \text{ Mpa}$$

$$\text{Stress intensity}$$

$$S_{12} = |\sigma_1 - \sigma_2| = 10.4 \text{ Mpa} \quad S_{23} = |\sigma_2 - \sigma_3| = 7.6 \text{ Mpa} \quad S_{31} = |\sigma_3 - \sigma_1| = 18.0 \text{ Mpa}$$

$$\text{Maximum stress intensity} \quad S = \max ( S_{12} , S_{23} , S_{31} ) \quad S = 18.0 \text{ Mpa}$$

$$S < 1.5 \cdot S_n \quad \text{Design OK}$$

FileName : 1158-FRONT

Rectves Analysis : FRONT

Item: 1 11:41a Jul 20,2024

**Input Echo, COMPONENT 1, Description: FRONT**

```

Figure Number Analyzed                A8

Design Internal Pressure                P          22.0000 bars
Design Temperature                    Temp       120.0000 C

VESSEL MATERIAL DATA:
Material Specification                 SA-516 70
Shell Allowable Stress at Design Temp S          137.9000 N./mm^2
Shell Allowable Stress at Ambient     SA          137.9000 N./mm^2
Shell Yield Stress at Design Temperature Sy       235.9761 N./mm^2

SHORT-SIDE VESSEL DATA:
Short-side Length Dimension           H          100.0000 mm.
Minimum Thickness of Short-side Plates t1         20.0000 mm.
Mid-side Joint Efficiency on Short-side E           0.8500
Corner Joint Efficiency on Short-side EC          0.8500

LONG-SIDE VESSEL DATA:
Long-side Length Dimension            h          140.0000 mm.
Minimum Thickness of Long-side Plates t2         20.0000 mm.
Mid-side Joint Efficiency on Long-side E           0.8500

ADDITIONAL VESSEL DATA:
Minimum Thickness of End Plate        t5         20.0000 mm.
C-Factor for End Plate                Cf_Epl     0.2000
Corrosion Allowance of Shell          CA         3.0000 mm.

Long-side Plate # 1,
  Pitch Distance                      p          69.8500 mm.
  # 1: Hole Diameter                  d0         36.5000 mm.
  Hole Depth                          T0         1.7000 mm.
  # 2: Hole Diameter                  d1         28.6000 mm.
  Hole Depth                          T1         18.3000 mm.
Long-side Plate # 2,
  Pitch Distance                      p          69.8500 mm.
  Uniform Hole Diameter                d0         25.7000 mm.
  Depth of Holes                      T0         20.0000 mm.

STAY PLATE MATERIAL DATA:
Stay Material Specification           SA-516 70
Stay Allowable Stress at Design Temp Sr          137.9000 N./mm^2
Stay Allowable Stress at Ambient     SA          137.9000 N./mm^2
Stay Yield Stress at Design Temp     Sy          235.9761 N./mm^2

STAY PLATE DATA:
Minimum Thickness of Stay             t3         12.0000 mm.
Minimum Thickness of Stay             t4         12.0000 mm.
The Stay(s) Are Not Welded to the End Plate
Corrosion Allowance of Stay          CAS         3.0000 mm.
    
```

**Rectangular Vessel Results, Item number 1, Desc: FRONT  
ASME Code, Section VIII, Division 1, 2017 App. 13**

**Ligament Efficiency Calculations (Section 13-6, Equations (1)-(6)):**

**Short-side 1 Calculations**

Membrane Ligament Efficiency [Em]:  
= 0.850

Bending Ligament Efficiency [Eb]:  
= 0.850

Dist from Neutral axis of c/s to inside surface of the vessel [Ci]:  
= t1 - CA / 2  
= 20.000 - 3.000 / 2  
= 8.500 mm.

FileName : 1158-FRONT

Rectves Analysis : FRONT

Item: 1 11:41a Jul 20,2024

Dist from Neutral axis of c/s to extreme outside surface of the section [Co]:

$$\begin{aligned}
 &= -(t_1 - CA) / 2 \\
 &= -(20.000 - 3.000) / 2 \\
 &= -8.500 \text{ mm.}
 \end{aligned}$$

**Short-side 2 Calculations**

Membrane Ligament Efficiency [Em]:

$$= 0.850$$

Bending Ligament Efficiency [Eb]:

$$= 0.850$$

Dist from Neutral axis of c/s to inside surface of the vessel [Ci]:

$$\begin{aligned}
 &= t_1 - CA / 2 \\
 &= 20.000 - 3.000 / 2 \\
 &= 8.500 \text{ mm.}
 \end{aligned}$$

Dist from Neutral axis of c/s to extreme outside surface of the section [Co]:

$$\begin{aligned}
 &= -(t_1 - CA) / 2 \\
 &= -(20.000 - 3.000) / 2 \\
 &= -8.500 \text{ mm.}
 \end{aligned}$$

**Long-side 1 Calculations**

Effective Diameter [De]:

$$\begin{aligned}
 &= (d_0 * T_0 + d_1 * T_1 + d_2 * T_2) / (t_1 - CA) \\
 &= (36.50 * 1.70 + 28.60 * 15.30 + 0.00 * 0.00) / \\
 &\quad (20.00 - 3.00) \\
 &= 29.390 \text{ mm.}
 \end{aligned}$$

Membrane Ligament Efficiency [Em]:

$$\begin{aligned}
 &= \text{Pitch} - De / \text{Pitch} \\
 &= 69.850 - 29.390 / 69.850 \\
 &= 0.579
 \end{aligned}$$

Dist from Neutral axis of c/s to extreme fibers [Ci &amp; Co]:

**Calculation of Xbar:**

$$\begin{aligned}
 &= ((b_0 * T_0 * (T_0/2 + T_1 + T_2)) + (b_1 * T_1 * \\
 &\quad (T_1/2 + T_2)) + (b_2 * T_2 * (T_2/2))) / \\
 &\quad (b_0 * T_0 + b_1 * T_1 + b_2 * T_2) \\
 &= ((1.31 * 1.70 * (1.70/2 + 15.30 + 0.00)) + (1.62 * 15.30 * \\
 &\quad (15.30/2 + 0.00)) + (2.75 * 0.00 * (0.00/2))) / \\
 &\quad (1.31 * 1.70 + 1.62 * 15.30 + 2.75 * 0.00) \\
 &= 8.351 \text{ mm.}
 \end{aligned}$$

Dist from Neutral axis of c/s to inside surface of the vessel [Ci]:

 $C_i = X_{bar}$ 

$$= 8.351 \text{ mm.}$$

Dist from Neutral axis of c/s to extreme outside surface of the section [Co]:

$$\begin{aligned}
 &= -(t - CA - X_{bar}) \\
 &= -(20.000 - 3.000 - 8.351) \\
 &= -8.649 \text{ mm.}
 \end{aligned}$$

Moment of Inertia (Section 13-6, Equation (5)) [I]:

$$= 0.063 \text{ cm}^4$$

Effective Diameter [De]:

$$\begin{aligned}
 &= \text{Pitch} - ((6 * I) / ((t - CA)^2 * (-Co))) \\
 &= 69.85 - ((6 * 0.06) / ((20.00 - 3.00)^2 * (8.65))) \\
 &= 31.244 \text{ mm.}
 \end{aligned}$$

Bending Ligament Efficiency [Eb]:

$$\begin{aligned}
 &= \text{Pitch} - De / \text{Pitch} \\
 &= 69.850 - 31.244 / 69.850 \\
 &= 0.553
 \end{aligned}$$

**Long-side 2 Calculations**

Effective Diameter [De]: 25.700 mm.

Membrane Ligament Efficiency [Em]:  
 = Pitch - De / Pitch  
 = 69.850 - 25.700 / 69.850  
 = 0.632

Bending Ligament Efficiency [Eb]:  
 As diameter holes are uniform Eb = Em  
 = 0.632

Dist from Neutral axis of c/s to inside surface of the vesssel [Ci]:  
 = t1 - CA / 2  
 = 20.000 - 3.000 / 2  
 = 8.500 mm.

Dist from Neutral axis of c/s to extreme outside surface of the section [Co]:  
 = -( t1 - CA ) / 2  
 = -( 20.000 - 3.000 ) / 2  
 = -8.500 mm.

**Ligament Efficiency Calculations (Section 13-6, Equations (1)-(6)):**

	Em	Eb	Ci	Co
Short-side 1	0.850	0.850	8.500	-8.500
2	0.850	0.850	8.500	-8.500
Long-side 1	0.579	0.553	8.351	-8.649
2	0.632	0.632	8.500	-8.500

**Moment of Inertia of a Strip of the Vessel Wall:**

Thickness t1, I1 = 0.0409 cm\*\*4  
 Thickness t2, I2 = 0.0409 cm\*\*4

**Rectangular Vessel Parameters:**

Alpha = H / h = 0.7260  
 K = (I2/I1)\*Alpha = 0.7260

**Membrane Stress Calculations per Section 13-9**

**Membrane Stresses at Short-side 1**

Membrane Stress at Short-side 1 [Sms]:  
 = P \* h / ( 2 \* t1 ) \* { 3 - [ ( 6 + K \* ( 11 - alpha^2 ) / ( 3 + 5 \* K ) ) ] }  
 = 22.00 \* 146.00 / ( 2 \* 17.00 ) \* { 3 - [ ( 6 + 0.73 \* ( 11 - 0.73^2 ) / ( 3 + 5 \* 0.73 ) ) ] }  
 = 8.96 N./mm^2

**Membrane Stresses at Short-side 2**

Membrane Stress at Short-side 2 [Sms]:  
 = P \* h / ( 2 \* t1 ) \* { 3 - [ ( 6 + K \* ( 11 - alpha^2 ) / ( 3 + 5 \* K ) ) ] }  
 = 22.00 \* 146.00 / ( 2 \* 17.00 ) \* { 3 - [ ( 6 + 0.73 \* ( 11 - 0.73^2 ) / ( 3 + 5 \* 0.73 ) ) ] }  
 = 8.96 N./mm^2

**Membrane Stresses at Long-side 1**

Membrane Stress at Long-side 1 at A [Sml]:  
 = P \* H / 2 \* t2  
 = 22.00 \* 106.00 / 2 \* 17.00  
 = 6.86 N./mm^2

If Em( 0.579 ) < E( 0.850 ) and Eb( 0.553 ) < E( 0.850 ) then  
 Sml = Sml / Em  
 = 6.86 / 0.58

FileName : 1158-FRONT

Rectves Analysis : FRONT

Item: 1 11:41a Jul 20,2024

$$= 11.84 \text{ N./mm}^2$$

**Membrane Stresses at Long-side 2**

Membrane Stress at Long-side 2 at A [Sml]:

$$= P * H / 2 * t^2$$

$$= 22.00 * 106.00 / 2 * 17.00$$

$$= 6.86 \text{ N./mm}^2$$

If  $E_m(0.632) < E(0.850)$  and  $E_b(0.632) < E(0.850)$  then

$$S_{ml} = S_{ml} / E_m$$

$$= 6.86 / 0.63$$

$$= 10.85 \text{ N./mm}^2$$

**Membrane Stresses at Stay Plate**

Membrane Stress at Stay Plate [t3]:

$$= P * h / ( 2 * t^3 ) * [ ( 6 + K * ( 11 - \alpha^2 ) / ( 3 + 5 * K ) ) ]$$

$$= 22.00 * 146.00 / ( 2 * 6.00 ) * [ ( 6 + 0.73 * ( 11 - 0.73^2 ) / ( 3 + 5 * 0.73 ) ) ]$$

$$= 54.92 \text{ N./mm}^2$$

Membrane Stress at Stay Plate [t4]:

$$= P * h / ( 2 * t^4 ) * [ ( 6 + K * ( 11 - \alpha^2 ) / ( 3 + 5 * K ) ) ]$$

$$= 22.00 * 146.00 / ( 2 * 6.00 ) * [ ( 6 + 0.73 * ( 11 - 0.73^2 ) / ( 3 + 5 * 0.73 ) ) ]$$

$$= 54.92 \text{ N./mm}^2$$

**MEMBRANE STRESSES: Membrane Stress Calculations per Section 13-9, Equations (13-15). (N./mm<sup>2</sup>) :**

STRESS LOCATIONS	Actual	Allowable
Short-side 1	8.96	117.22
Short-side 2	8.96	117.22
Short-side Corner	8.96	117.22
Long-side 1 at A	11.84	137.90
Long-side 2 at A	10.85	137.90
Long-side Corner	6.86	117.22
Stay Plate (t3)	54.92	137.90
Stay Plate (t4)	54.92	137.90

**Bending Stress Calculations per Section 13-9**

**Bending Stresses at Short-side 1**

Bending Stress at Short-side 1 at N Inner[SbsNi]:

$$= P * c / ( 24 * I_1 ) * [ -3 * H^2 + 2 * h^2 * ( ( 3 + 5 * \alpha^2 * K ) / ( 3 + 5 * K ) ) ]$$

$$= 22.00 * 8.50 / ( 24 * 0.04 ) * [ -3 * 106.00^2 + 2 * 146.00^2 * ( ( 3 + 5 * 0.73^2 * 0.73 ) / ( 3 + 5 * 0.73 ) ) ]$$

$$= -4.02 \text{ N./mm}^2$$

Bending Stress at Short-side 1 at N Outer[SbsNo]:

$$= P * c / ( 24 * I_1 ) * [ -3 * H^2 + 2 * h^2 * ( ( 3 + 5 * \alpha^2 * K ) / ( 3 + 5 * K ) ) ]$$

$$= 22.00 * -8.50 / ( 24 * 0.04 ) * [ -3 * 106.00^2 + 2 * 146.00^2 * ( ( 3 + 5 * 0.73^2 * 0.73 ) / ( 3 + 5 * 0.73 ) ) ]$$

$$= 4.02 \text{ N./mm}^2$$

Bending Stress at Short-side 1 at Q Inner[SbsQi]:

$$= P * h^2 * c / ( 12 * I_1 ) * ( ( 3 + 5 * \alpha^2 * K ) / ( 3 + 5 * K ) )$$

$$= 22.00 * 146.00^2 * 8.50 / ( 12 * 0.04 ) * ( ( 3 + 5 * 0.73^2 * 0.73 ) / ( 3 + 5 * 0.73 ) )$$

$$= 60.13 \text{ N./mm}^2$$

Bending Stress at Short-side 1 at Q Outer[SbsQo]:

$$= P * h^2 * c / ( 12 * I_1 ) * ( ( 3 + 5 * \alpha^2 * K ) / ( 3 + 5 * K ) )$$

FileName : 1158-FRONT

Rectves Analysis : FRONT

Item: 1 11:41a Jul 20,2024

$$= 22.00 * 146.00^2 * -8.50 / ( 12 * 0.04 ) * (( 3 + 5 * 0.73^2 * 0.73 ) / ( 3 + 5 * 0.73 ))$$

$$= -60.13 \text{ N./mm}^2$$

**Bending Stresses at Short-side 2**

Bending Stress at Short-side 2 at N Inner[SbsNi]:

$$= P * c / ( 24 * I1 ) * [ -3 * H^2 + 2 * h^2 * (( 3 + 5 * Alpha^2 * K ) / ( 3 + 5 * K )) ]$$

$$= 22.00 * 8.50 / ( 24 * 0.04 ) * [ -3 * 106.00^2 + 2 * 146.00^2 * (( 3 + 5 * 0.73^2 * 0.73 ) / ( 3 + 5 * 0.73 )) ]$$

$$= -4.02 \text{ N./mm}^2$$

Bending Stress at Short-side 2 at N Outer[SbsNo]:

$$= P * c / ( 24 * I1 ) * [ -3 * H^2 + 2 * h^2 * (( 3 + 5 * Alpha^2 * K ) / ( 3 + 5 * K )) ]$$

$$= 22.00 * -8.50 / ( 24 * 0.04 ) * [ -3 * 106.00^2 + 2 * 146.00^2 * (( 3 + 5 * 0.73^2 * 0.73 ) / ( 3 + 5 * 0.73 )) ]$$

$$= 4.02 \text{ N./mm}^2$$

Bending Stress at Short-side 2 at Q Inner[SbsQi]:

$$= P * h^2 * c / ( 12 * I1 ) * (( 3 + 5 * Alpha^2 * K ) / ( 3 + 5 * K ))$$

$$= 22.00 * 146.00^2 * 8.50 / ( 12 * 0.04 ) * (( 3 + 5 * 0.73^2 * 0.73 ) / ( 3 + 5 * 0.73 ))$$

$$= 60.13 \text{ N./mm}^2$$

Bending Stress at Short-side 2 at Q Outer[SbsQo]:

$$= P * h^2 * c / ( 12 * I1 ) * (( 3 + 5 * Alpha^2 * K ) / ( 3 + 5 * K ))$$

$$= 22.00 * 146.00^2 * -8.50 / ( 12 * 0.04 ) * (( 3 + 5 * 0.73^2 * 0.73 ) / ( 3 + 5 * 0.73 ))$$

$$= -60.13 \text{ N./mm}^2$$

**Bending Stresses at Long-side 1**

Bending Stress at Long-side 1 at M Inner[SblMi]:

$$= P * h^2 * c / ( 12 * I2 ) * [( 3 + K * ( 6 - Alpha^2 ) ) / ( 3 + 5 * K )]$$

$$= 22.00 * 146.00^2 * 8.35 / ( 12 * 0.04 ) * [( 3 + 0.73 * ( 6 - 0.73^2 ) ) / ( 3 + 5 * 0.73 )]$$

$$= 83.84 \text{ N./mm}^2$$

If  $E_m(0.579) < E(0.850)$  and  $E_b(0.553) < E(0.850)$  then

$$SblMi = SblMi / Eb$$

$$= 83.84 / 0.55$$

$$= 151.69 \text{ N./mm}^2$$

Bending Stress at Long-side 1 at M Outer[SblMo]:

$$= P * h^2 * c / ( 12 * I2 ) * [( 3 + K * ( 6 - Alpha^2 ) ) / ( 3 + 5 * K )]$$

$$= 22.00 * 146.00^2 * -8.65 / ( 12 * 0.04 ) * [( 3 + 0.73 * ( 6 - 0.73^2 ) ) / ( 3 + 5 * 0.73 )]$$

$$= -86.84 \text{ N./mm}^2$$

If  $E_m(0.579) < E(0.850)$  and  $E_b(0.553) < E(0.850)$  then

$$SblMo = SblMo / Eb$$

$$= -86.84 / 0.55$$

$$= -157.12 \text{ N./mm}^2$$

Bending Stress at Long-side 1 at Q Inner[SblQi]:

$$= P * h^2 * c / ( 12 * I2 ) * [( 3 + 5 * Alpha^2 * K ) / ( 3 + 5 * K )]$$

$$= 22.00 * 146.00^2 * 8.35 / ( 12 * 0.04 ) * [( 3 + 5 * 0.73^2 * 0.73 ) / ( 3 + 5 * 0.73 )]$$

$$= 59.07 \text{ N./mm}^2$$

Bending Stress at Long-side 1 at Q Outer[SblQo]:

$$= P * h^2 * c / ( 12 * I2 ) * [( 3 + 5 * Alpha^2 * K ) / ( 3 + 5 * K )]$$

FileName : 1158-FRONT

Rectves Analysis : FRONT

Item: 1 11:41a Jul 20,2024

$$= 22.00 * 146.00^2 * -8.65 / ( 12 * 0.04 ) * [ ( 3 + 5 * 0.73^2 * 0.73 ) / ( 3 + 5 * 0.73 ) ]$$

$$= -61.19 \text{ N./mm}^2$$

**Bending Stresses at Long-side 2**

Bending Stress at Long-side 2 at M Inner[SblMi]:

$$= P * h^2 * c / ( 12 * I2 ) * [ ( 3 + K * ( 6 - Alpha^2) ) / ( 3 + 5 * K ) ]$$

$$= 22.00 * 146.00^2 * 8.50 / ( 12 * 0.04 ) * [ ( 3 + 0.73 * ( 6 - 0.73^2) ) / ( 3 + 5 * 0.73 ) ]$$

$$= 85.34 \text{ N./mm}^2$$

If  $E_m(0.632) < E(0.850)$  and  $E_b(0.632) < E(0.850)$  then

$$SblMi = SblMi / Eb$$

$$= 85.34 / 0.63$$

$$= 135.02 \text{ N./mm}^2$$

Bending Stress at Long-side 2 at M Outer[SblMo]:

$$= P * h^2 * c / ( 12 * I2 ) * [ ( 3 + K * ( 6 - Alpha^2) ) / ( 3 + 5 * K ) ]$$

$$= 22.00 * 146.00^2 * -8.50 / ( 12 * 0.04 ) * [ ( 3 + 0.73 * ( 6 - 0.73^2) ) / ( 3 + 5 * 0.73 ) ]$$

$$= -85.34 \text{ N./mm}^2$$

If  $E_m(0.632) < E(0.850)$  and  $E_b(0.632) < E(0.850)$  then

$$SblMo = SblMo / Eb$$

$$= -85.34 / 0.63$$

$$= -135.02 \text{ N./mm}^2$$

Bending Stress at Long-side 2 at Q Inner[SblQi]:

$$= P * h^2 * c / ( 12 * I2 ) * [ ( 3 + 5 * Alpha^2 * K ) / ( 3 + 5 * K ) ]$$

$$= 22.00 * 146.00^2 * 8.50 / ( 12 * 0.04 ) * [ ( 3 + 5 * 0.73^2 * 0.73 ) / ( 3 + 5 * 0.73 ) ]$$

$$= 60.13 \text{ N./mm}^2$$

Bending Stress at Long-side 2 at Q Outer[SblQo]:

$$= P * h^2 * c / ( 12 * I2 ) * [ ( 3 + 5 * Alpha^2 * K ) / ( 3 + 5 * K ) ]$$

$$= 22.00 * 146.00^2 * -8.50 / ( 12 * 0.04 ) * [ ( 3 + 5 * 0.73^2 * 0.73 ) / ( 3 + 5 * 0.73 ) ]$$

$$= -60.13 \text{ N./mm}^2$$

**BENDING STRESSES: Bending Stress Calculations per Section 13-9, Equations (16-19). (N./mm<sup>2</sup>) :**

STRESS LOCATIONS	Inner	Outer	Allowable
Short-side 1 at N	-4.02	4.02	175.82
at Q	60.13	-60.13	175.82
Short-side 2 at N	-4.02	4.02	175.82
at Q	60.13	-60.13	175.82
Long-side 1 at M	151.69	-157.12	206.85
at Q	59.07	-61.19	175.82
Long-side 2 at M	135.02	-135.02	206.85
at Q	60.13	-60.13	175.82

**Total Stress Calculations per Section 13-9**

**Total Stresses at Short-side 1**

Total Stress at short side 1 at N inner [STS\_Ni]:

$$= Sms + SbsNi$$

$$= 8.96 + -4.02$$

$$= 4.93 \text{ N./mm}^2$$

Total Stress at short side 1 at N outer [STS\_No]:

$$= Sms + SbsNo$$

$$= 8.96 + 4.02$$

$$= 12.98 \text{ N./mm}^2$$

FileName : 1158-FRONT

Rectves Analysis : FRONT

Item: 1 11:41a Jul 20,2024

Total Stress at short side 1 at Q inner [STS\_Qi]:

$$\begin{aligned} &= S_{ms} + S_{bsQi} \\ &= 8.96 + 60.13 \\ &= 69.09 \text{ N./mm}^2 \end{aligned}$$

Total Stress at short side 1 at Q outer [STS\_Qo]:

$$\begin{aligned} &= S_{ms} + S_{bsQo} \\ &= 8.96 + -60.13 \\ &= -51.17 \text{ N./mm}^2 \end{aligned}$$

**Total Stresses at Short-side 2**

Total Stress at short side 2 at N inner [STS\_Ni]:

$$\begin{aligned} &= S_{ms} + S_{bsNi} \\ &= 8.96 + -4.02 \\ &= 4.93 \text{ N./mm}^2 \end{aligned}$$

Total Stress at short side 2 at N outer [STS\_No]:

$$\begin{aligned} &= S_{ms} + S_{bsNo} \\ &= 8.96 + 4.02 \\ &= 12.98 \text{ N./mm}^2 \end{aligned}$$

Total Stress at short side 2 at Q inner [STS\_Qi]:

$$\begin{aligned} &= S_{ms} + S_{bsQi} \\ &= 8.96 + 60.13 \\ &= 69.09 \text{ N./mm}^2 \end{aligned}$$

Total Stress at short side 2 at Q outer [STS\_Qo]:

$$\begin{aligned} &= S_{ms} + S_{bsQo} \\ &= 8.96 + -60.13 \\ &= -51.17 \text{ N./mm}^2 \end{aligned}$$

**Total Stresses at Long-side 1**

Total Stress at long side 1 at M inner [STL\_Mi]:

$$\begin{aligned} &= S_{m1} + S_{b1Mi} \\ &= 11.84 + 151.69 \\ &= 163.53 \text{ N./mm}^2 \end{aligned}$$

Total Stress at long side 1 at M outer [STL\_Mo]:

$$\begin{aligned} &= S_{m1} + S_{b1Mo} \\ &= 11.84 + -157.12 \\ &= -145.28 \text{ N./mm}^2 \end{aligned}$$

Total Stress at long side 1 at Q inner [STL\_Qi]:

$$\begin{aligned} &= S_{m1} + S_{b1Qi} \\ &= 6.86 + 59.07 \\ &= 65.93 \text{ N./mm}^2 \end{aligned}$$

Total Stress at long side 1 at Q outer [STL\_Qo]:

$$\begin{aligned} &= S_{m1} + S_{b1Qo} \\ &= 6.86 + -61.19 \\ &= -54.33 \text{ N./mm}^2 \end{aligned}$$

**Total Stresses at Long-side 2**

Total Stress at long side 2 at M inner [STL\_Mi]:

$$\begin{aligned} &= S_{m1} + S_{b1Mi} \\ &= 10.85 + 135.02 \\ &= 145.87 \text{ N./mm}^2 \end{aligned}$$

Total Stress at long side 2 at M outer [STL\_Mo]:

$$\begin{aligned} &= S_{m1} + S_{b1Mo} \\ &= 10.85 + -135.02 \\ &= -124.16 \text{ N./mm}^2 \end{aligned}$$

Total Stress at long side 2 at Q inner [STL\_Qi]:

$$\begin{aligned} &= S_{m1} + S_{b1Qi} \\ &= 6.86 + 60.13 \end{aligned}$$

FileName : 1158-FRONT

Rectves Analysis : FRONT

Item: 1 11:41a Jul 20,2024

= 66.99 N./mm<sup>2</sup>

Total Stress at long side 2 at Q outer [STL\_Qo]:

= SmlB + SblQo  
 = 6.86 + -60.13  
 = -53.27 N./mm<sup>2</sup>

**TOTAL STRESSES: Total Stress Calculations per Section 13-9, Equations (20-24). (N./mm<sup>2</sup>) :**

STRESS LOCATIONS	Inner	Outer	Allowable
Short-side 1 at N	4.93	12.98	175.82
at Q	69.09	-51.17	175.82
Short-side 2 at N	4.93	12.98	175.82
at Q	69.09	-51.17	175.82
Long-side 1 at M	163.53	-145.28	206.85
at Q	65.93	-54.33	175.82
Long-side 2 at M	145.87	-124.16	206.85
at Q	66.99	-53.27	175.82

**END PLATE STRESSES (N./mm<sup>2</sup>) :**

	Actual	Allowable
End Plate	42.77	137.90

**SUMMARY OF RESULTS:**

**MEMBRANE STRESS SUMMARY,**

High Stress (Highest % of Allowable)	54.92	N./mm <sup>2</sup>
High Stress Percentage	39.83	%
M.A.W.P. for Membrane Stresses	55.24	bars

**BENDING STRESS SUMMARY,**

High Stress (Highest % of Allowable)	-157.12	N./mm <sup>2</sup>
High Stress Percentage	75.96	%
M.A.W.P. for Bending Stresses	28.96	bars

**TOTAL STRESS SUMMARY,**

High Stress (Highest % of Allowable)	163.53	N./mm <sup>2</sup>
High Stress Percentage	79.06	%
M.A.W.P. for Total Stresses	27.83	bars

**Rectangular Vessel Results For Item 1 : A8**

**SUMMARY OF RESULTS:**

**MEMBRANE STRESS SUMMARY,**

High Stress (Highest % of Allowable)	54.92	N./mm <sup>2</sup>
High Stress Percentage	39.83	%
M.A.W.P. for Membrane Stresses	55.24	bars

**BENDING STRESS SUMMARY,**

High Stress (Highest % of Allowable)	-157.12	N./mm <sup>2</sup>
High Stress Percentage	75.96	%
M.A.W.P. for Bending Stresses	28.96	bars

**TOTAL STRESS SUMMARY,**

High Stress (Highest % of Allowable)	163.53	N./mm <sup>2</sup>
High Stress Percentage	79.06	%
M.A.W.P. for Total Stresses	27.83	bars

FileName : 1158-REAR

Rectves Analysis : REAR

Item: 1 11:36a Jul 20,2024

**Input Echo, COMPONENT 1, Description: REAR**

```

Figure Number Analyzed                A7

Design Internal Pressure                P          22.0000 bars
Design Temperature                    Temp       120.0000 C

VESSEL MATERIAL DATA:
Material Specification                SA-516 70
Shell Allowable Stress at Design Temp S          137.9000 N./mm^2
Shell Allowable Stress at Ambient     SA          137.9000 N./mm^2
Shell Yield Stress at Design Temperature Sy       235.9761 N./mm^2

SHORT-SIDE VESSEL DATA:
Short-side Length Dimension           H          100.0000 mm.
Minimum Thickness of Short-side Plates t1         20.0000 mm.
Mid-side Joint Efficiency on Short-side E           0.8500
Corner Joint Efficiency on Short-side EC          0.8500

LONG-SIDE VESSEL DATA:
Long-side Length Dimension            h          138.0000 mm.
Minimum Thickness of Long-side Plates t2         20.0000 mm.
Mid-side Joint Efficiency on Long-side E           0.8500

ADDITIONAL VESSEL DATA:
Minimum Thickness of End Plate        t5         20.0000 mm.
C-Factor for End Plate                Cf_Epl     0.2000
Corrosion Allowance of Shell          CA         3.0000 mm.

Long-side Plate # 1,
  Pitch Distance                      p          69.8500 mm.
  # 1: Hole Diameter                  d0         36.5000 mm.
  Hole Depth                          T0         1.7000 mm.
  # 2: Hole Diameter                  d1         28.6000 mm.
  Hole Depth                          T1         18.3000 mm.
Long-side Plate # 2,
  Pitch Distance                      p          69.8500 mm.
  Uniform Hole Diameter                d0         25.7000 mm.
  Depth of Holes                      T0         20.0000 mm.

STAY PLATE MATERIAL DATA:
Stay Material Specification            SA-516 70
Stay Allowable Stress at Design Temp Sr          137.9000 N./mm^2
Stay Allowable Stress at Ambient     SA          137.9000 N./mm^2
Stay Yield Stress at Design Temp     Sy          235.9761 N./mm^2

STAY PLATE DATA:
Minimum Thickness of Stay              t3         12.0000 mm.
The Stay(s) Are Not Welded to the End Plate
Corrosion Allowance of Stay           CAS        3.0000 mm.
    
```

**Rectangular Vessel Results, Item number 1, Desc: REAR**  
**ASME Code, Section VIII, Division 1, 2017 App. 13**

**Ligament Efficiency Calculations (Section 13-6, Equations (1)-(6)):**

**Short-side 1 Calculations**

Membrane Ligament Efficiency [Em]:  
 = 0.850

Bending Ligament Efficiency [Eb]:  
 = 0.850

Dist from Neutral axis of c/s to inside surface of the vessel [Ci]:  
 = t1 - CA / 2  
 = 20.000 - 3.000 / 2  
 = 8.500 mm.

FileName : 1158-REAR

Rectves Analysis : REAR

Item: 1 11:36a Jul 20,2024

Dist from Neutral axis of c/s to extreme outside surface of the section [Co]:

$$\begin{aligned}
 &= -(t_1 - CA) / 2 \\
 &= -(20.000 - 3.000) / 2 \\
 &= -8.500 \text{ mm.}
 \end{aligned}$$

**Short-side 2 Calculations**

Membrane Ligament Efficiency [Em]:

$$= 0.850$$

Bending Ligament Efficiency [Eb]:

$$= 0.850$$

Dist from Neutral axis of c/s to inside surface of the vessel [Ci]:

$$\begin{aligned}
 &= t_1 - CA / 2 \\
 &= 20.000 - 3.000 / 2 \\
 &= 8.500 \text{ mm.}
 \end{aligned}$$

Dist from Neutral axis of c/s to extreme outside surface of the section [Co]:

$$\begin{aligned}
 &= -(t_1 - CA) / 2 \\
 &= -(20.000 - 3.000) / 2 \\
 &= -8.500 \text{ mm.}
 \end{aligned}$$

**Long-side 1 Calculations**

Effective Diameter [De]:

$$\begin{aligned}
 &= (d_0 * T_0 + d_1 * T_1 + d_2 * T_2) / (t_1 - CA) \\
 &= (36.50 * 1.70 + 28.60 * 15.30 + 0.00 * 0.00) / \\
 &\quad (20.00 - 3.00) \\
 &= 29.390 \text{ mm.}
 \end{aligned}$$

Membrane Ligament Efficiency [Em]:

$$\begin{aligned}
 &= \text{Pitch} - De / \text{Pitch} \\
 &= 69.850 - 29.390 / 69.850 \\
 &= 0.579
 \end{aligned}$$

Dist from Neutral axis of c/s to extreme fibers [Ci &amp; Co]:

*Calculation of Xbar:*

$$\begin{aligned}
 &= ((b_0 * T_0 * (T_0/2 + T_1 + T_2)) + (b_1 * T_1 * \\
 &\quad (T_1/2 + T_2)) + (b_2 * T_2 * (T_2/2))) / \\
 &\quad (b_0 * T_0 + b_1 * T_1 + b_2 * T_2) \\
 &= ((1.31 * 1.70 * (1.70/2 + 15.30 + 0.00)) + (1.62 * 15.30 * \\
 &\quad (15.30/2 + 0.00)) + (2.75 * 0.00 * (0.00/2))) / \\
 &\quad (1.31 * 1.70 + 1.62 * 15.30 + 2.75 * 0.00) \\
 &= 8.351 \text{ mm.}
 \end{aligned}$$

Dist from Neutral axis of c/s to inside surface of the vessel [Ci]:

 $C_i = X_{bar}$ 

$$= 8.351 \text{ mm.}$$

Dist from Neutral axis of c/s to extreme outside surface of the section [Co]:

$$\begin{aligned}
 &= -(t - CA - X_{bar}) \\
 &= -(20.000 - 3.000 - 8.351) \\
 &= -8.649 \text{ mm.}
 \end{aligned}$$

Moment of Inertia (Section 13-6, Equation (5)) [I]:

$$= 0.063 \text{ cm}^4$$

Effective Diameter [De]:

$$\begin{aligned}
 &= \text{Pitch} - ((6 * I) / ((t - CA)^2 * (-Co))) \\
 &= 69.85 - ((6 * 0.06) / ((20.00 - 3.00)^2 * (8.65))) \\
 &= 31.244 \text{ mm.}
 \end{aligned}$$

Bending Ligament Efficiency [Eb]:

$$\begin{aligned}
 &= \text{Pitch} - De / \text{Pitch} \\
 &= 69.850 - 31.244 / 69.850 \\
 &= 0.553
 \end{aligned}$$

**Long-side 2 Calculations**

FileName : 1158-REAR -----

Rectves Analysis : REAR

Item: 1 11:36a Jul 20,2024

Effective Diameter [De]: 25.700 mm.

Membrane Ligament Efficiency [Em]:

$$= \text{Pitch} - \text{De} / \text{Pitch}$$

$$= 69.850 - 25.700 / 69.850$$

$$= 0.632$$

Bending Ligament Efficiency [Eb]:

As diameter holes are uniform  $E_b = E_m$

$$= 0.632$$

Dist from Neutral axis of c/s to inside surface of the vessel [Ci]:

$$= t_1 - \text{CA} / 2$$

$$= 20.000 - 3.000 / 2$$

$$= 8.500 \text{ mm.}$$

Dist from Neutral axis of c/s to extreme outside surface of the section [Co]:

$$= - ( t_1 - \text{CA} ) / 2$$

$$= - ( 20.000 - 3.000 ) / 2$$

$$= -8.500 \text{ mm.}$$

**Ligament Efficiency Calculations (Section 13-6, Equations (1)-(6)):**

	Em	Eb	Ci	Co
Short-side 1	0.850	0.850	8.500	-8.500
2	0.850	0.850	8.500	-8.500
Long-side 1	0.579	0.553	8.351	-8.649
2	0.632	0.632	8.500	-8.500

**Moment of Inertia of a Strip of the Vessel Wall:**

$$\text{Thickness } t_1, I_1 = 0.0409 \text{ cm}^{**4}$$

$$\text{Thickness } t_2, I_2 = 0.0409 \text{ cm}^{**4}$$

**Rectangular Vessel Parameters:**

$$\text{Alpha} = H / h = 0.7361$$

$$K = (I_2/I_1) * \text{Alpha} = 0.7361$$

**Membrane Stress Calculations per Section 13-9**

**Membrane Stresses at Short-side 1**

Membrane Stress at Short-side 1 [Sms]:

$$= p * h / ( 4 * t_1 ) * \{ 4 - [ ( 2 + K * ( 5 - \text{alpha}^2) ) / ( 1 + 2 * K ) ] \}$$

$$= 22.00 * 144.00 / ( 4 * 17.00 ) * \{ 4 - [ ( 2 + 0.74 * ( 5 - 0.74^2) ) / ( 1 + 2 * 0.74 ) ] \}$$

$$= 8.68 \text{ N./mm}^2$$

**Membrane Stresses at Short-side 2**

Membrane Stress at Short-side 2 [Sms]:

$$= p * h / ( 4 * t_1 ) * \{ 4 - [ ( 2 + K * ( 5 - \text{alpha}^2) ) / ( 1 + 2 * K ) ] \}$$

$$= 22.00 * 144.00 / ( 4 * 17.00 ) * \{ 4 - [ ( 2 + 0.74 * ( 5 - 0.74^2) ) / ( 1 + 2 * 0.74 ) ] \}$$

$$= 8.68 \text{ N./mm}^2$$

**Membrane Stresses at Long-side 1**

Membrane Stress at Long-side 1 at A [Sml]:

$$= P * H / 2 * t_2$$

$$= 22.00 * 106.00 / 2 * 17.00$$

$$= 6.86 \text{ N./mm}^2$$

If  $E_m(0.579) < E(0.850)$  and  $E_b(0.553) < E(0.850)$  then

$$S_{ml} = S_{ml} / E_m$$

$$= 6.86 / 0.58$$

$$= 11.84 \text{ N./mm}^2$$

**Membrane Stresses at Long-side 2**

Membrane Stress at Long-side 2 at A [Sml]:

$$= P * H / 2 * t^2$$

$$= 22.00 * 106.00 / 2 * 17.00$$

$$= 6.86 \text{ N./mm}^2$$

If  $E_m(0.632) < E(0.850)$  and  $E_b(0.632) < E(0.850)$  then

$$S_{ml} = S_{ml} / E_m$$

$$= 6.86 / 0.63$$

$$= 10.85 \text{ N./mm}^2$$

**Membrane Stresses at Stay Plate**

Membrane Stress at Stay Plate [Smsp]:

$$= P * h / ( 2 * t^3 ) * [ ( 2 + K * ( 5 - \alpha^2 ) ) / ( 1 + 2 * K ) ]$$

$$= 22.00 * 144.00 / ( 2 * 6.00 ) * [ ( 2 + 0.74 * ( 5 - 0.74^2 ) ) / ( 1 + 2 * 0.74 ) ]$$

$$= 56.40 \text{ N./mm}^2$$

**MEMBRANE STRESSES: Membrane Stress Calculations per Section 13-9, Equations (1-3). (N./mm<sup>2</sup>) :**

STRESS LOCATIONS	Actual	Allowable
Short-side 1	8.68	117.22
Short-side 2	8.68	117.22
Short-side Corner	8.68	117.22
Long-side 1 at A	11.84	137.90
Long-side 2 at A	10.85	137.90
Long-side Corner	6.86	117.22
Stay Plate (t3)	56.40	137.90

**Bending Stress Calculations per Section 13-9**

**Bending Stresses at Short-side 1**

Bending Stress at Short-side 1 at N Inner[SbsNi]:

$$= P * c / ( 24 * I_1 ) * [ -3 * H^2 + 2 * h^2 * ( ( 1 + 2 * \alpha^2 * K ) / ( 1 + 2 * K ) ) ]$$

$$= 22.00 * 8.50 / ( 24 * 0.04 ) * [ -3 * 106.00^2 + 2 * 144.00^2 * ( ( 1 + 2 * 0.74^2 * 0.74 ) / ( 1 + 2 * 0.74 ) ) ]$$

$$= -6.76 \text{ N./mm}^2$$

Bending Stress at Short-side 1 at N Outer[SbsNo]:

$$= P * c / ( 24 * I_1 ) * [ -3 * H^2 + 2 * h^2 * ( ( 1 + 2 * \alpha^2 * K ) / ( 1 + 2 * K ) ) ]$$

$$= 22.00 * -8.50 / ( 24 * 0.04 ) * [ -3 * 106.00^2 + 2 * 144.00^2 * ( ( 1 + 2 * 0.74^2 * 0.74 ) / ( 1 + 2 * 0.74 ) ) ]$$

$$= 6.76 \text{ N./mm}^2$$

Bending Stress at Short-side 1 at Q Inner[SbsQi]:

$$= P * h^2 * c / ( 12 * I_1 ) * ( ( 1 + 2 * \alpha^2 * K ) / ( 1 + 2 * K ) )$$

$$= 22.00 * 144.00^2 * 8.50 / ( 12 * 0.04 ) * ( ( 1 + 2 * 0.74^2 * 0.74 ) / ( 1 + 2 * 0.74 ) )$$

$$= 57.40 \text{ N./mm}^2$$

Bending Stress at Short-side 1 at Q Outer[SbsQo]:

$$= P * h^2 * c / ( 12 * I_1 ) * ( ( 1 + 2 * \alpha^2 * K ) / ( 1 + 2 * K ) )$$

$$= 22.00 * 144.00^2 * -8.50 / ( 12 * 0.04 ) * ( ( 1 + 2 * 0.74^2 * 0.74 ) / ( 1 + 2 * 0.74 ) )$$

$$= -57.40 \text{ N./mm}^2$$

**Bending Stresses at Short-side 2**

Bending Stress at Short-side 2 at N Inner[SbsNi]:

$$= P * c / ( 24 * I_1 ) * [ -3 * H^2 + 2 * h^2 * ( ( 1 + 2 * \alpha^2 * K ) / ( 1 + 2 * K ) ) ]$$

FileName : 1158-REAR -----

Rectves Analysis : REAR Item: 1 11:36a Jul 20,2024

$$= 22.00 * 8.50 / ( 24 * 0.04 ) * [ -3 * 106.00^2 + 2 * 144.00^2 * (( 1 + 2 * 0.74^2 * 0.74 ) / ( 1 + 2 * 0.74 )) ]$$

$$= -6.76 \text{ N./mm}^2$$

**Bending Stress at Short-side 2 at N Outer[SbsNo]:**

$$= P * c / ( 24 * I1 ) * [ -3 * H^2 + 2 * h^2 * (( 1 + 2 * Alpha^2 * K ) / ( 1 + 2 * K )) ]$$

$$= 22.00 * -8.50 / ( 24 * 0.04 ) * [ -3 * 106.00^2 + 2 * 144.00^2 * (( 1 + 2 * 0.74^2 * 0.74 ) / ( 1 + 2 * 0.74 )) ]$$

$$= 6.76 \text{ N./mm}^2$$

**Bending Stress at Short-side 2 at Q Inner[SbsQi]:**

$$= P * h^2 * c / ( 12 * I1 ) * (( 1 + 2 * Alpha^2 * K ) / ( 1 + 2 * K ))$$

$$= 22.00 * 144.00^2 * 8.50 / ( 12 * 0.04 ) * (( 1 + 2 * 0.74^2 * 0.74 ) / ( 1 + 2 * 0.74 ))$$

$$= 57.40 \text{ N./mm}^2$$

**Bending Stress at Short-side 2 at Q Outer[SbsQo]:**

$$= P * h^2 * c / ( 12 * I1 ) * (( 1 + 2 * Alpha^2 * K ) / ( 1 + 2 * K ))$$

$$= 22.00 * 144.00^2 * -8.50 / ( 12 * 0.04 ) * (( 1 + 2 * 0.74^2 * 0.74 ) / ( 1 + 2 * 0.74 ))$$

$$= -57.40 \text{ N./mm}^2$$

**Bending Stresses at Long-side 1**

**Bending Stress at Long-side 1 at M Inner[SblMi]:**

$$= P * h^2 * c / ( 12 * I2 ) * [( 1 + K * ( 3 - Alpha^2 ) ) / ( 1 + 2 * K )]$$

$$= 22.00 * 144.00^2 * 8.35 / ( 12 * 0.04 ) * [( 1 + 0.74 * ( 3 - 0.74^2 ) ) / ( 1 + 2 * 0.74 )]$$

$$= 88.12 \text{ N./mm}^2$$

*If Em( 0.579 ) < E( 0.850 ) and Eb( 0.553 ) < E( 0.850 ) then*

$$SblMi = SblMi / Eb$$

$$= 88.12 / 0.55$$

$$= 159.44 \text{ N./mm}^2$$

**Bending Stress at Long-side 1 at M Outer[SblMo]:**

$$= P * h^2 * c / ( 12 * I2 ) * [( 1 + K * ( 3 - Alpha^2 ) ) / ( 1 + 2 * K )]$$

$$= 22.00 * 144.00^2 * -8.65 / ( 12 * 0.04 ) * [( 1 + 0.74 * ( 3 - 0.74^2 ) ) / ( 1 + 2 * 0.74 )]$$

$$= -91.27 \text{ N./mm}^2$$

*If Em( 0.579 ) < E( 0.850 ) and Eb( 0.553 ) < E( 0.850 ) then*

$$SblMo = SblMo / Eb$$

$$= -91.27 / 0.55$$

$$= -165.14 \text{ N./mm}^2$$

**Bending Stress at Long-side 1 at Q Inner[SblQi]:**

$$= P * h^2 * c / ( 12 * I2 ) * [( 1 + 2 * Alpha^2 * K ) / ( 1 + 2 * K )]$$

$$= 22.00 * 144.00^2 * 8.35 / ( 12 * 0.04 ) * [( 1 + 2 * 0.74^2 * 0.74 ) / ( 1 + 2 * 0.74 )]$$

$$= 56.39 \text{ N./mm}^2$$

**Bending Stress at Long-side 1 at Q Outer[SblQo]:**

$$= P * h^2 * c / ( 12 * I2 ) * [( 1 + 2 * Alpha^2 * K ) / ( 1 + 2 * K )]$$

$$= 22.00 * 144.00^2 * -8.65 / ( 12 * 0.04 ) * [( 1 + 2 * 0.74^2 * 0.74 ) / ( 1 + 2 * 0.74 )]$$

$$= -58.40 \text{ N./mm}^2$$

**Bending Stresses at Long-side 2**

**Bending Stress at Long-side 2 at M Inner[SblMi]:**

$$= P * h^2 * c / ( 12 * I2 ) * [( 1 + K * ( 3 - Alpha^2 ) ) / ( 1 + 2 * K )]$$

FileName : 1158-REAR -----

Rectves Analysis : REAR Item: 1 11:36a Jul 20,2024

$$= 22.00 * 144.00^2 * 8.50 / ( 12 * 0.04 ) * [( 1 + 0.74 * ( 3 - 0.74^2) ) / ( 1 + 2 * 0.74 )]$$

$$= 89.70 \text{ N./mm}^2$$

If  $E_m(0.632) < E(0.850)$  and  $E_b(0.632) < E(0.850)$  then

$$S_{blMi} = S_{blMi} / E_b$$

$$= 89.70 / 0.63$$

$$= 141.91 \text{ N./mm}^2$$

Bending Stress at Long-side 2 at M Outer[SblMo]:

$$= P * h^2 * c / ( 12 * I_2 ) * [( 1 + K * ( 3 - \text{Alpha}^2) ) / ( 1 + 2 * K )]$$

$$= 22.00 * 144.00^2 * -8.50 / ( 12 * 0.04 ) * [( 1 + 0.74 * ( 3 - 0.74^2) ) / ( 1 + 2 * 0.74 )]$$

$$= -89.70 \text{ N./mm}^2$$

If  $E_m(0.632) < E(0.850)$  and  $E_b(0.632) < E(0.850)$  then

$$S_{blMo} = S_{blMo} / E_b$$

$$= -89.70 / 0.63$$

$$= -141.91 \text{ N./mm}^2$$

Bending Stress at Long-side 2 at Q Inner[SblQi]:

$$= P * h^2 * c / ( 12 * I_2 ) * [( 1 + 2 * \text{Alpha}^2 * K ) / ( 1 + 2 * K )]$$

$$= 22.00 * 144.00^2 * 8.50 / ( 12 * 0.04 ) * [( 1 + 2 * 0.74^2 * 0.74 ) / ( 1 + 2 * 0.74 )]$$

$$= 57.40 \text{ N./mm}^2$$

Bending Stress at Long-side 2 at Q Outer[SblQo]:

$$= P * h^2 * c / ( 12 * I_2 ) * [( 1 + 2 * \text{Alpha}^2 * K ) / ( 1 + 2 * K )]$$

$$= 22.00 * 144.00^2 * -8.50 / ( 12 * 0.04 ) * [( 1 + 2 * 0.74^2 * 0.74 ) / ( 1 + 2 * 0.74 )]$$

$$= -57.40 \text{ N./mm}^2$$

**BENDING STRESSES: Bending Stress Calculations per Section 13-9, Equations (4-7). (N./mm<sup>2</sup>) :**

STRESS LOCATIONS	Inner	Outer	Allowable
Short-side 1 at N	-6.76	6.76	175.82
at Q	57.40	-57.40	175.82
Short-side 2 at N	-6.76	6.76	175.82
at Q	57.40	-57.40	175.82
Long-side 1 at M	159.44	-165.14	206.85
at Q	56.39	-58.40	175.82
Long-side 2 at M	141.91	-141.91	206.85
at Q	57.40	-57.40	175.82

**Total Stress Calculations per Section 13-9**

**Total Stresses at Short-side 1**

Total Stress at short side 1 at N inner [STS\_Ni]:

$$= S_{ms} + S_{bsNi}$$

$$= 8.68 + -6.76$$

$$= 1.93 \text{ N./mm}^2$$

Total Stress at short side 1 at N outer [STS\_No]:

$$= S_{ms} + S_{bsNo}$$

$$= 8.68 + 6.76$$

$$= 15.44 \text{ N./mm}^2$$

Total Stress at short side 1 at Q inner [STS\_Qi]:

$$= S_{ms} + S_{bsQi}$$

$$= 8.68 + 57.40$$

$$= 66.08 \text{ N./mm}^2$$

Total Stress at short side 1 at Q outer [STS\_Qo]:

$$= S_{ms} + S_{bsQo}$$

$$= 8.68 + -57.40$$

FileName : 1158-REAR

Rectves Analysis : REAR

Item: 1 11:36a Jul 20,2024

$$= -48.71 \text{ N./mm}^2$$

**Total Stresses at Short-side 2**

Total Stress at short side 2 at N inner [STS\_Ni]:

$$\begin{aligned} &= S_{ms} + S_{bsNi} \\ &= 8.68 + -6.76 \\ &= 1.93 \text{ N./mm}^2 \end{aligned}$$

Total Stress at short side 2 at N outer [STS\_No]:

$$\begin{aligned} &= S_{ms} + S_{bsNo} \\ &= 8.68 + 6.76 \\ &= 15.44 \text{ N./mm}^2 \end{aligned}$$

Total Stress at short side 2 at Q inner [STS\_Qi]:

$$\begin{aligned} &= S_{ms} + S_{bsQi} \\ &= 8.68 + 57.40 \\ &= 66.08 \text{ N./mm}^2 \end{aligned}$$

Total Stress at short side 2 at Q outer [STS\_Qo]:

$$\begin{aligned} &= S_{ms} + S_{bsQo} \\ &= 8.68 + -57.40 \\ &= -48.71 \text{ N./mm}^2 \end{aligned}$$

**Total Stresses at Long-side 1**

Total Stress at long side 1 at M inner [STL\_Mi]:

$$\begin{aligned} &= S_{m1} + S_{b1Mi} \\ &= 11.84 + 159.44 \\ &= 171.28 \text{ N./mm}^2 \end{aligned}$$

Total Stress at long side 1 at M outer [STL\_Mo]:

$$\begin{aligned} &= S_{m1} + S_{b1Mo} \\ &= 11.84 + -165.14 \\ &= -153.30 \text{ N./mm}^2 \end{aligned}$$

Total Stress at long side 1 at Q inner [STL\_Qi]:

$$\begin{aligned} &= S_{m1} + S_{b1Qi} \\ &= 6.86 + 56.39 \\ &= 63.25 \text{ N./mm}^2 \end{aligned}$$

Total Stress at long side 1 at Q outer [STL\_Qo]:

$$\begin{aligned} &= S_{m1} + S_{b1Qo} \\ &= 6.86 + -58.40 \\ &= -51.55 \text{ N./mm}^2 \end{aligned}$$

**Total Stresses at Long-side 2**

Total Stress at long side 2 at M inner [STL\_Mi]:

$$\begin{aligned} &= S_{m1} + S_{b1Mi} \\ &= 10.85 + 141.91 \\ &= 152.76 \text{ N./mm}^2 \end{aligned}$$

Total Stress at long side 2 at M outer [STL\_Mo]:

$$\begin{aligned} &= S_{m1} + S_{b1Mo} \\ &= 10.85 + -141.91 \\ &= -131.06 \text{ N./mm}^2 \end{aligned}$$

Total Stress at long side 2 at Q inner [STL\_Qi]:

$$\begin{aligned} &= S_{m1} + S_{b1Qi} \\ &= 6.86 + 57.40 \\ &= 64.26 \text{ N./mm}^2 \end{aligned}$$

Total Stress at long side 2 at Q outer [STL\_Qo]:

$$\begin{aligned} &= S_{m1} + S_{b1Qo} \\ &= 6.86 + -57.40 \\ &= -50.54 \text{ N./mm}^2 \end{aligned}$$

**TOTAL STRESSES: Total Stress Calculations per Section 13-9,**

FileName : 1158-REAR

Rectves Analysis : REAR

Item: 1 11:36a Jul 20,2024

**Equations (8-12). (N./mm<sup>2</sup>) :**

STRESS LOCATIONS	Inner	Outer	Allowable
Short-side 1 at N	1.93	15.44	175.82
at Q	66.08	-48.71	175.82
Short-side 2 at N	1.93	15.44	175.82
at Q	66.08	-48.71	175.82
Long-side 1 at M	171.28	-153.30	206.85
at Q	63.25	-51.55	175.82
Long-side 2 at M	152.76	-131.06	206.85
at Q	64.26	-50.54	175.82

**END PLATE STRESSES (N./mm<sup>2</sup>) :**

	Actual	Allowable
End Plate	42.77	137.90

**SUMMARY OF RESULTS:**

**MEMBRANE STRESS SUMMARY,**

High Stress (Highest % of Allowable)	56.40	N./mm <sup>2</sup>
High Stress Percentage	40.90	%
M.A.W.P. for Membrane Stresses	53.79	bars

**BENDING STRESS SUMMARY,**

High Stress (Highest % of Allowable)	-165.14	N./mm <sup>2</sup>
High Stress Percentage	79.84	%
M.A.W.P. for Bending Stresses	27.56	bars

**TOTAL STRESS SUMMARY,**

High Stress (Highest % of Allowable)	171.28	N./mm <sup>2</sup>
High Stress Percentage	82.80	%
M.A.W.P. for Total Stresses	26.57	bars

**Rectangular Vessel Results For Item 1 : A7**

**SUMMARY OF RESULTS:**

**MEMBRANE STRESS SUMMARY,**

High Stress (Highest % of Allowable)	56.40	N./mm <sup>2</sup>
High Stress Percentage	40.90	%
M.A.W.P. for Membrane Stresses	53.79	bars

**BENDING STRESS SUMMARY,**

High Stress (Highest % of Allowable)	-165.14	N./mm <sup>2</sup>
High Stress Percentage	79.84	%
M.A.W.P. for Bending Stresses	27.56	bars

**TOTAL STRESS SUMMARY,**

High Stress (Highest % of Allowable)	171.28	N./mm <sup>2</sup>
High Stress Percentage	82.80	%
M.A.W.P. for Total Stresses	26.57	bars

**Tabular Results**

Results were generated with the finite element program FE/Pipe®. Stress results are post-processed in accordance with the rules specified in ASME Section III and ASME Section VIII, Division 2.

Analysis Time Stamp: Sat Jun 01 10:34:40 2024.

- [Model Notes, Tube Results and API Check](#)
- [Load Case Report](#)
- [Solution Data](#)
- [ASME Code Stress Output Plots](#)
- [Stress Results - Notes](#)
- [ASME Overstressed Areas](#)
- [Highest Primary Stress Ratios](#)
- [Highest Secondary Stress Ratios](#)
- [Highest Fatigue Stress Ratios](#)
- [Graphical Results](#)

Model Notes, Tube Results and API Check  
Model Notes, Tube Results and API Check

661PRO 2.0 - API 661 - Air-Cooled Heat Exchanger Nozzle Model

Input Echo:

Notes:

- The centerline of the header box is along the -Z axis.
- Only 1 Nozzle will be modeled at a time. The Nozzle Number Modeled can be seen below.

Nozzle Number Modeled : 1  
Top or Bottom Nozzle : Top  
  
Analysis Type : API 661 Evaluation  
  
Nozzle Type : Straight  
Flange Type : Weldneck

Header Box Dimensions:  
Centerline on :Centerline on LEFT Side  
Height : 389.000 mm.  
Width : 140.000 mm.  
Length : 2510.000 mm.

Outboard Thickness : 17.000 mm.  
Tubesheet Side Thickness : 17.000 mm.  
Top Plate Thickness : 17.000 mm.  
Free End Plate Thickness : 17.000 mm.

Header Box Pressure : 2.200 MPa

Header Box Fixed at Centerline

Partition Plates:  
Number of Partition Plates : 2

Partition Plate #1  
Plate Elevation from Bottom : 149.000 mm.  
Plate Thickness : 6.000 mm.

Partition Plate #2  
Plate Elevation from Bottom : 301.000 mm.  
Plate Thickness : 6.000 mm.

Nozzle Dimensions:  
Distance to CenterLine : 1255.000 mm.  
Nozzle Outside Diameter : 114.000 mm.  
Nozzle Thickness : 8.800 mm.

Projection to Face of Flange : 200.000 mm.  
 Flange Thickness Used : 21.706 mm.  
 Flange ID : 136.069 mm.  
 Flange Hub Length Used : 32.559 mm.

Weld Size and SCF : 0.000, 1.350

Engineering Details:

Operating Cycles : 7000  
 Occasional Cycles : 0  
 Ambient Temperature : 21.100 deg.  
 Computation Type : Gauss Average

Material Properties

Nozzle:

Cold Allowable Stress : 117.900 MPa  
 Hot Allowable Stress : 117.900 MPa  
 Elastic Modulus : 0.203E+06 MPa  
 Poissons Ratio : 0.300  
 Material ID :1-Low Carbon Steels  
 Density : 0.768E-04 N /cu. mm.

Header Box:

Cold Allowable Stress : 137.900 MPa  
 Hot Allowable Stress : 137.900 MPa  
 Elastic Modulus : 0.203E+06 MPa  
 Poissons Ratio : 0.300  
 Material ID :2-Low Alloy Steels  
 Density : 0.768E-04 N /cu. mm.

Tubesheet was not modeled

API Loads Applied:

API Multiplier : 3.000

Forces [ N ]	Moments [ mm.- N ]					
	FX	FY	FZ	MX	MY	MZ
Weight	10020	8010	10020	2430000	3660000	2430000
Operating	10020	8010	10020	2430000	3660000	2430000

No Tube Results

[Table of Contents](#)

---

Load Case Report  
 FE/Pipe Version 7.0 Jobname: setup2 \$P  
 Released Jul 2014 10:31am JUN 1,2024

Load Case Report \$X

Inner and outer element temperatures are the same throughout the model. No thermal ratcheting calculations will be performed.

THE 2 LOAD CASES ANALYZED ARE:

1 SUSTAINED (Pr Only)

Sustained case run to satisfy local primary membrane and bending stress limits.

/----- Loads in Case 1  
 Pressure Case 1

2 OPERATING (Fatigue Calc Performed)

Case run to compute the operating stresses used in

secondary, peak and range calculations as needed.

/----- Loads in Case 2  
 Pressure Case 1  
 Loads from (Operating)

[Table of Contents](#)

---

Solution Data  
 FE/Pipe Version 7.0 Jobname: setup2 \$P  
 Released Jul 2014 10:32am JUN 1,2024

Solution Data

Maximum Solution Row Size = 1728  
 Number of Nodes = 12063  
 Number of Elements = 4107  
 Number of Solution Cases = 2

Summation of Loads per Case

Case #	FX	FY	FZ
1	0.	-44871.	-100663.
2	10020.	-20804.	-90643.

[Table of Contents](#)

---

ASME Code Stress Output Plots  
 FE/Pipe Version 7.0 Jobname: setup2 \$P  
 Released Jul 2014 10:34am JUN 1,2024

ASME Code Stress Output Plots \$X

- 1)  $P_l < 1.5(k)Sm_h$  (SUS,Membrane) Case 1
- 2)  $Q_b < 3(Sm_h)$  (SUS,Bending) Case 1
- 3)  $S_1+S_2+S_3 < 4S$  (SUS, $S_1+S_2+S_3$ ) Case 1
- 4)  $P_l+P_b+Q < 3(Sm_{avg})$  (OPE,Inside) Case 2
- 5)  $P_l+P_b+Q < 3(Sm_{avg})$  (OPE,Outside) Case 2
- 6)  $P_l+P_b+Q+F < S_a$  (EXP,Inside) Case 2
- 7)  $P_l+P_b+Q+F < S_a$  (EXP,Outside) Case 2
- 8) Membrane < User (OPE,Membrane) Case 2
- 9) Bending < User (OPE,Bending) Case 2

[Table of Contents](#)

---

Stress Results - Notes  
 FE/Pipe Version 7.0 Jobname: setup2 \$P  
 Released Jul 2014 10:34am JUN 1,2024

Stress Results - Notes

- Results in this analysis were generated using the finite element solution method.

- Using pre 07 ASME Section VIII Division 2
- Assume free end displacements of attached pipe are secondary loads within limits of nozzle reinforcement.
- Use Stress Intensity (TRESCA).
- S1+S2+S3 evaluation omitted from operating stress. Include S1+S2+S3 evaluation in primary case evaluation. Assume bending stress not local primary for S1+S2+S3.
- Use local tensor values for averaged and not averaged stresses.
  - PRIMARY STRESSES are similar to the B31 code "sustained" stresses. Primary stresses contain the effects due to weight, pressure and other sustained loads. The primary limit for this stress is based on collapse of the local cross section or excessive local strain.
  - SECONDARY (PL+PB+Q) STRESS has no direct equal in a B31 code. This stress requirement is intended to insure that significant inelastic behavior only occurs for the first few loading cycles, and only over a fairly small region of the model. "Small" is on the order of the square root of Rt, where (R) is the radius of the header and (t) is the thickness of the header. Secondary stresses do not include the effect of peak stress concentration factors such as occur at fillets, welds or notches.
  - PEAK STRESSES are equivalent to the B31 code "expansion" stresses. In the peak stress report, the user will find the equivalent B31 allowable computed from:  $f[1.25(Sc+Sh)]$ .
  - The LOCAL STRESS calculations performed herein are in accordance with ASME VIII Div 2, Part 5, elastic calculations, and ASME Section III Subsection NB. These methods have been used extensively in the nuclear piping industry, and have been shown to be in consistent agreement with the B31 piping codes when the simplifying assumptions made in the B31 codes are employed.
  - The B31 Code Stress Calculations performed herein are in accordance with the method outlined in NUREG/CR-3243 and (ORNL/Sub/82-22252/1). This paper shows the relationship between the fatigue evaluation methods used in the B31 codes and the class 1,2 and 3 nuclear piping codes.
  - When the number of design cycles is less than 7000, (which is the default), the B31 user is cautioned against using a smaller number of design cycles to satisfy the intersection allowables unless he is sure that the material can easily undergo significant peak plastic deformation without crack propagation.
  - Thru-the-wall temperature effects may be important when the temperature difference is high. The stress resulting from the difference is independant of the thickness. Users should estimate and enter this difference if available.
  - Membrane stresses are the stresses averaged thru the wall of the component. Secondary and Peak stresses are those that are maximums at the outer fiber of the local cross section due primarily to plate or shell type bending at the nozzle or discontinuity.

[Table of Contents](#)

ASME Overstressed Areas  
 FE/Pipe Version 7.0                      Jobname: setup2                      \$P  
 Released Jul 2014                      10:34am JUN 1,2024

ASME Overstressed Areas                      \$X

\*\*\* NO OVERSTRESSED NODES IN THIS MODEL \*\*\*

[Table of Contents](#)

## Highest Primary Stress Ratios

FE/Pipe Version 7.0  
Released Jul 2014Jobname: setup2  
10:34am JUN 1,2024

\$P

## Highest Primary Stress Ratios

\$X

## Circ Plate for Plate # 1

Qb	3 (Smh)
57	414
MPa	MPa
13%	

Primary Bending Load Case 1  
Sect VIII Ref: 4-112(h) (2), Table 4-120.1,  
Fig.4-130.1, 4-133  
Plot Reference:  
2) Qb < 3(Smh) (SUS,Bending) Case 1

## Long Plate for Plate # 1

Qb	3 (Smh)
41	414
MPa	MPa
9%	

Primary Bending Load Case 1  
Sect VIII Ref: 4-112(h) (2), Table 4-120.1,  
Fig.4-130.1, 4-133  
Plot Reference:  
2) Qb < 3(Smh) (SUS,Bending) Case 1

## Circ Plate for Plate # 2

Qb	3 (Smh)
57	414
MPa	MPa
13%	

Primary Bending Load Case 1  
Sect VIII Ref: 4-112(h) (2), Table 4-120.1,  
Fig.4-130.1, 4-133  
Plot Reference:  
2) Qb < 3(Smh) (SUS,Bending) Case 1

## Circ Plate for Plate # 3

Pl	1.5(k) Smh
24	177
MPa	MPa
13%	

Primary Membrane Load Case 1  
Sect VIII Ref: AD-140, 4-112(i), 4-133,  
Fig. 4-130.1, Table 4-120.1  
Plot Reference:  
1) Pl < 1.5(k) Smh (SUS,Membrane) Case 1

## Circ Plate for Plate # 4

Pl	1.5(k) Smh
15	177
MPa	MPa
8%	

Primary Membrane Load Case 1  
Sect VIII Ref: AD-140, 4-112(i), 4-133,  
Fig. 4-130.1, Table 4-120.1  
Plot Reference:  
1) Pl < 1.5(k) Smh (SUS,Membrane) Case 1

## Long Plate for Plate # 4

Pl	1.5(k) Smh
4	177
MPa	MPa
2%	

Primary Membrane Load Case 1  
Sect VIII Ref: AD-140, 4-112(i), 4-133,  
Fig. 4-130.1, Table 4-120.1  
Plot Reference:  
1) Pl < 1.5(k) Smh (SUS,Membrane) Case 1

[Table of Contents](#)

## Highest Secondary Stress Ratios

FE/Pipe Version 7.0  
Released Jul 2014Jobname: setup2  
10:34am JUN 1,2024

\$P

## Highest Secondary Stress Ratios

\$X

## Circ Plate for Plate # 1

Pl+Pb+Q	3 (Smavg)
---------	-----------

Primary+Secondary (Outer) Load Case 2

93 MPa	414 MPa	Sect VIII Ref: 4-120(b) (4), 4-134, 4-136.6, Fig. 4-130.1 (Note 1) Plot Reference: 5) Pl+Pb+Q < 3 (Smavg) (OPE, Outside) Case 2
22%		
Long Plate for Plate # 1		
Pl+Pb+Q 154 MPa	3 (Smavg) 414 MPa	Primary+Secondary (Outer) Load Case 2 Sect VIII Ref: 4-120(b) (4), 4-134, 4-136.6, Fig. 4-130.1 (Note 1) Plot Reference: 5) Pl+Pb+Q < 3 (Smavg) (OPE, Outside) Case 2
37%		
Circ Plate for Plate # 2		
Pl+Pb+Q 103 MPa	3 (Smavg) 414 MPa	Primary+Secondary (Outer) Load Case 2 Sect VIII Ref: 4-120(b) (4), 4-134, 4-136.6, Fig. 4-130.1 (Note 1) Plot Reference: 5) Pl+Pb+Q < 3 (Smavg) (OPE, Outside) Case 2
24%		
Circ Plate for Plate # 3		
Pl+Pb+Q 252 MPa	3 (Smavg) 354 MPa	Primary+Secondary (Inner) Load Case 2 Sect VIII Ref: 4-120(b) (4), 4-134, 4-136.6, Fig. 4-130.1 (Note 1) Plot Reference: 4) Pl+Pb+Q < 3 (Smavg) (OPE, Inside) Case 2
71%		
Circ Plate for Plate # 4		
Pl+Pb+Q 163 MPa	3 (Smavg) 354 MPa	Primary+Secondary (Inner) Load Case 2 Sect VIII Ref: 4-120(b) (4), 4-134, 4-136.6, Fig. 4-130.1 (Note 1) Plot Reference: 4) Pl+Pb+Q < 3 (Smavg) (OPE, Inside) Case 2
46%		
Long Plate for Plate # 4		
Pl+Pb+Q 40 MPa	3 (Smavg) 354 MPa	Primary+Secondary (Outer) Load Case 2 Sect VIII Ref: 4-120(b) (4), 4-134, 4-136.6, Fig. 4-130.1 (Note 1) Plot Reference: 5) Pl+Pb+Q < 3 (Smavg) (OPE, Outside) Case 2
11%		

[Table of Contents](#)

## Highest Fatigue Stress Ratios

FE/Pipe Version 7.0  
Released Jul 2014

Jobname: setup2  
10:34am JUN 1, 2024

\$P

## Highest Fatigue Stress Ratios

\$X

## Circ Plate for Plate # 1

Pl+Pb+Q+F 46 MPa	Sa 290 MPa	Primary+Secondary+Peak (Outer) Load Case 2 Stress Concentration Factor = 1.000 Strain Concentration Factor = 1.000 Cycles Allowed for this Stress = 1.0000E11 "B31" Fatigue Stress Allowable = 344.8 Markl Fatigue Stress Allowable = 287.5 WRC 474 Mean Cycles to Failure = 5,667,978. WRC 474 99% Probability Cycles = 1,316,723. WRC 474 95% Probability Cycles = 1,828,104. BS5500 Allowed Cycles (Curve F) = 866,038. Membrane-to-Bending Ratio = 0.428 Bending-to-PL+PB+Q Ratio = 0.700 Sect VIII Ref: 4-112(1) (2), Fig. 4-130.1, 4-135 Plot Reference: 7) Pl+Pb+Q+F < Sa (EXP, Outside) Case 2
16%		

## Long Plate for Plate # 1

Pl+Pb+Q+F	Sa	Primary+Secondary+Peak (Outer) Load Case 2
77	290	Stress Concentration Factor = 1.000
MPa	MPa	Strain Concentration Factor = 1.000
		Cycles Allowed for this Stress = 5,630,432.
26%		"B31" Fatigue Stress Allowable = 344.8
		Mark1 Fatigue Stress Allowable = 287.5
		WRC 474 Mean Cycles to Failure = 1,092,708.
		WRC 474 99% Probability Cycles = 253,846.
		WRC 474 95% Probability Cycles = 352,433.
		BS5500 Allowed Cycles(Curve F) = 188,223.
		Membrane-to-Bending Ratio = 1.240
		Bending-to-PL+PB+Q Ratio = 0.446
		Sect VIII Ref: 4-112(1) (2), Fig.4-130.1,4-135
		Plot Reference:
		7) Pl+Pb+Q+F < Sa (EXP,Outside) Case 2

## Circ Plate for Plate # 2

Pl+Pb+Q+F	Sa	Primary+Secondary+Peak (Outer) Load Case 2
51	290	Stress Concentration Factor = 1.000
MPa	MPa	Strain Concentration Factor = 1.000
		Cycles Allowed for this Stress = 2.1644E10
17%		"B31" Fatigue Stress Allowable = 344.8
		Mark1 Fatigue Stress Allowable = 287.5
		WRC 474 Mean Cycles to Failure = 4,189,100.
		WRC 474 99% Probability Cycles = 973,166.
		WRC 474 95% Probability Cycles = 1,351,118.
		BS5500 Allowed Cycles(Curve F) = 644,104.
		Membrane-to-Bending Ratio = 0.508
		Bending-to-PL+PB+Q Ratio = 0.663
		Sect VIII Ref: 4-112(1) (2), Fig.4-130.1,4-135
		Plot Reference:
		7) Pl+Pb+Q+F < Sa (EXP,Outside) Case 2

## Circ Plate for Plate # 3

Pl+Pb+Q+F	Sa	Primary+Secondary+Peak (Inner) Load Case 2
126	290	Stress Concentration Factor = 1.000
MPa	MPa	Strain Concentration Factor = 1.000
		Cycles Allowed for this Stress = 128,241.
43%		"B31" Fatigue Stress Allowable = 294.8
		Mark1 Fatigue Stress Allowable = 287.5
		WRC 474 Mean Cycles to Failure = 407,669.
		WRC 474 99% Probability Cycles = 94,705.
		WRC 474 95% Probability Cycles = 131,486.
		BS5500 Allowed Cycles(Curve F) = 43,236.
		Membrane-to-Bending Ratio = 0.423
		Bending-to-PL+PB+Q Ratio = 0.702
		Sect VIII Ref: 4-112(1) (2), Fig.4-130.1,4-135
		Plot Reference:
		6) Pl+Pb+Q+F < Sa (EXP,Inside) Case 2

## Circ Plate for Plate # 4

Pl+Pb+Q+F	Sa	Primary+Secondary+Peak (Inner) Load Case 2
81	290	Stress Concentration Factor = 1.000
MPa	MPa	Strain Concentration Factor = 1.000
		Cycles Allowed for this Stress = 2,139,100.
28%		"B31" Fatigue Stress Allowable = 294.8
		Mark1 Fatigue Stress Allowable = 287.5
		WRC 474 Mean Cycles to Failure = 1,506,033.
		WRC 474 99% Probability Cycles = 349,865.
		WRC 474 95% Probability Cycles = 485,744.
		BS5500 Allowed Cycles(Curve F) = 160,509.
		Membrane-to-Bending Ratio = 0.830
		Bending-to-PL+PB+Q Ratio = 0.546
		Sect VIII Ref: 4-112(1) (2), Fig.4-130.1,4-135
		Plot Reference:
		6) Pl+Pb+Q+F < Sa (EXP,Inside) Case 2

## Long Plate for Plate # 4

Pl+Pb+Q+F	Sa	Primary+Secondary+Peak (Outer) Load Case 2
20	290	Stress Concentration Factor = 1.000
MPa	MPa	Strain Concentration Factor = 1.000
		Cycles Allowed for this Stress = 1.0000E11
6%		"B31" Fatigue Stress Allowable = 294.8
		Mark1 Fatigue Stress Allowable = 287.5
		WRC 474 Mean Cycles to Failure = 39,790,176.
		WRC 474 99% Probability Cycles = 9,243,610.

WRC 474 95% Probability Cycles = 12,833,602.  
 BS5500 Allowed Cycles(Curve F) = 6,339,758.  
 Membrane-to-Bending Ratio = 0.515  
 Bending-to-PL+PB+Q Ratio = 0.660  
 Sect VIII Ref: 4-112(1)(2), Fig.4-130.1,4-135  
 Plot Reference:  
 7) Pl+Pb+Q+F < Sa (EXP,Outside) Case 2

Circ Plate for Plate # 5

Pl+Pb+Q+F	Sa	Primary+Secondary+Peak (Inner) Load Case 2
35	290	Stress Concentration Factor = 1.000
MPa	MPa	Strain Concentration Factor = 1.000
		Cycles Allowed for this Stress = 1.0000E11
12%		"B31" Fatigue Stress Allowable = 0.0
		MarkI Fatigue Stress Allowable = 287.5
		WRC 474 Mean Cycles to Failure = 24,762,802.
		WRC 474 99% Probability Cycles = 5,752,618.
		WRC 474 95% Probability Cycles = 7,986,786.
		BS5500 Allowed Cycles(Curve F) = 1,950,751.
		Membrane-to-Bending Ratio = 2.775
		Bending-to-PL+PB+Q Ratio = 0.265
		Sect VIII Ref: 4-112(1)(2), Fig.4-130.1,4-135
		Plot Reference:
		6) Pl+Pb+Q+F < Sa (EXP,Inside) Case 2

[Table of Contents](#)

*Finite Element Model*

- [Finite Element Model](#)
- [1\)  \$PI < 1.5\(k\)Smh\$  \(SUS Membrane\) Case 1](#)
- [2\)  \$Qb < 3\(Smh\)\$  \(SUS Bending\) Case 1](#)
- [3\)  \$S1+S2+S3 < 4S\$  \(SUS  \$S1+S2+S3\$ \) Case 1](#)
- [4\)  \$PI+Pb+Q < 3\(Smavg\)\$  \(OPE Inside\) Case 2](#)
- [5\)  \$PI+Pb+Q < 3\(Smavg\)\$  \(OPE Outside\) Case 2](#)
- [6\)  \$PI+Pb+Q+F < Sa\$  \(EXP Inside\) Case 2](#)
- [7\)  \$PI+Pb+Q+F < Sa\$  \(EXP Outside\) Case 2](#)
- [8\) Membrane < User \(OPE Membrane\) Case 2](#)
- [9\) Bending < User \(OPE Bending\) Case 2](#)

Finite Element Model

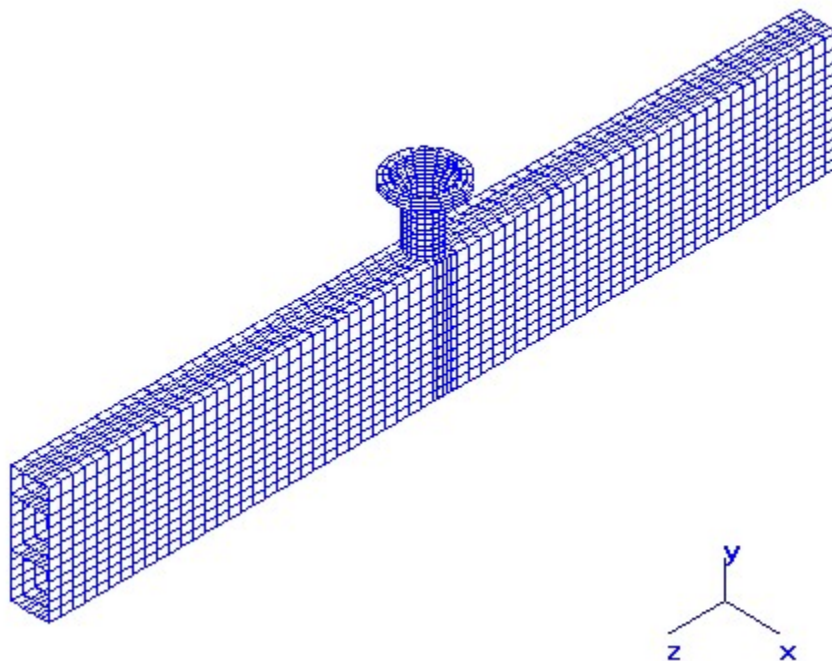

3d

1) P1 < 1.5(k)Smh (SUS\_Membrane)\_Case 1

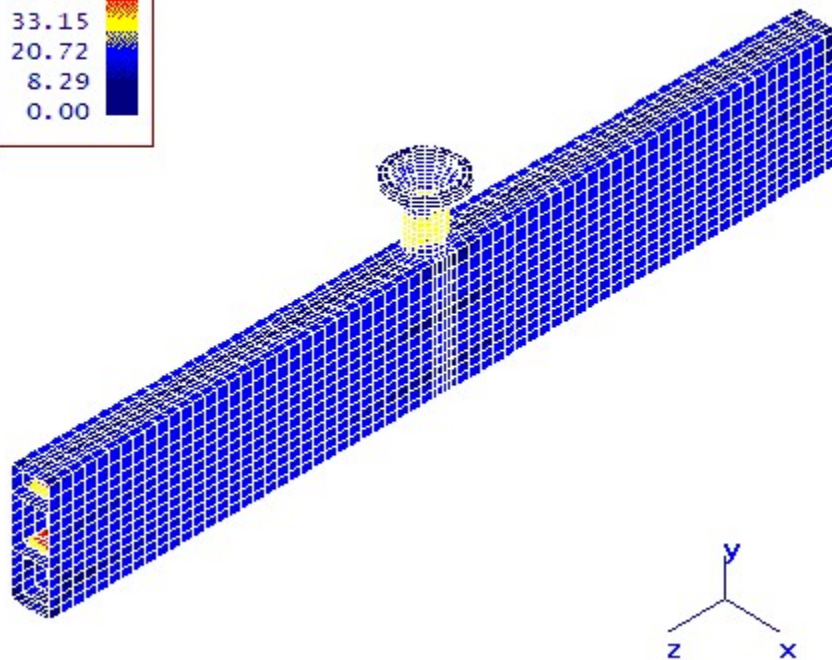
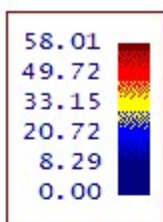

3d

3d(Deformed)

2)  $Q_b < 3(Smh)$  (SUS Bending) Case 1

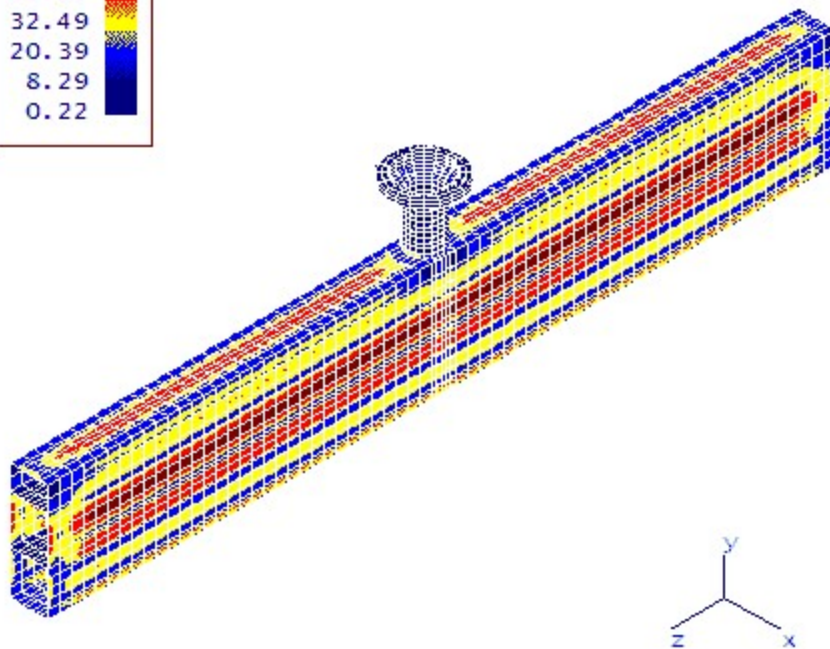
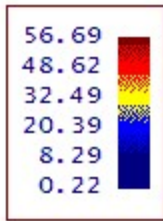

3d 3d(Deformed)

3)  $S1+S2+S3 < 4S$  (SUS  $S1+S2+S3$ ) Case 1

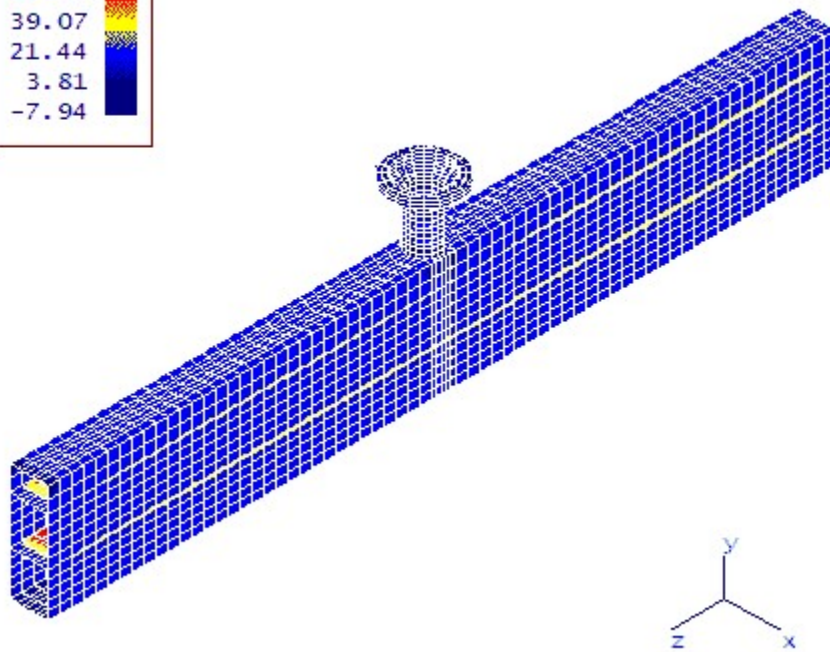
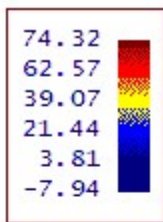

3d 3d(Deformed)

4)  $P1+Pb+Q < 3(Smavg)$  (OPE Inside) Case 2

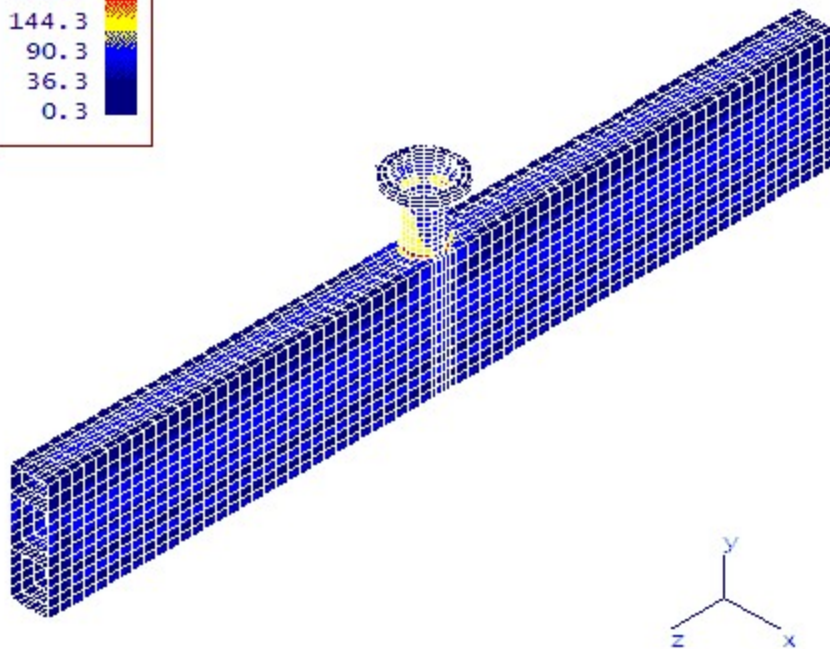
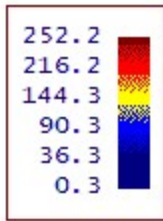

3d 3d(Deformed)

5)  $P1+Pb+Q < 3(Smavg)$  (OPE Outside) Case 2

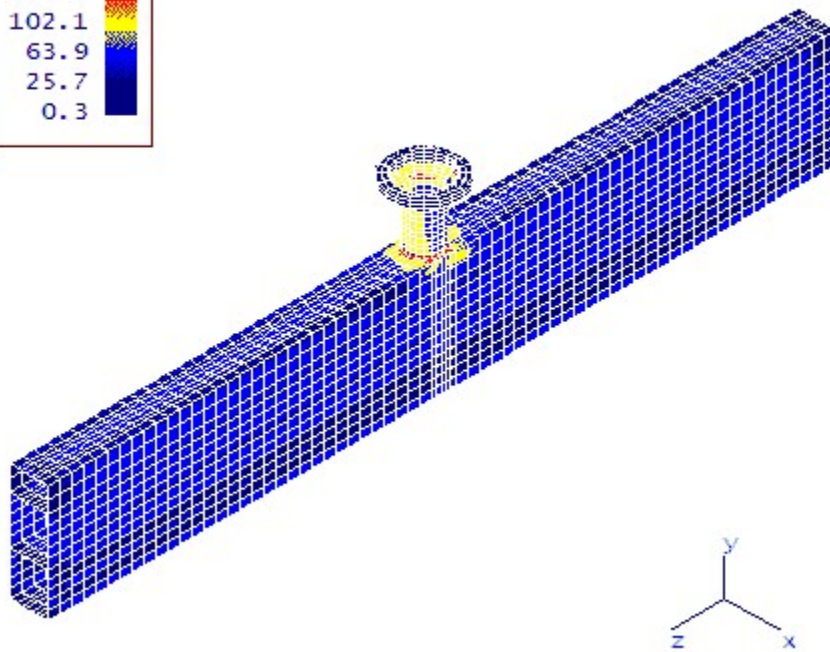
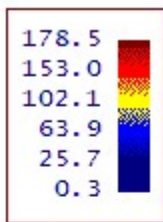

3d 3d(Deformed)

6)  $P1+Pb+Q+F < Sa$  (EXP Inside) Case 2

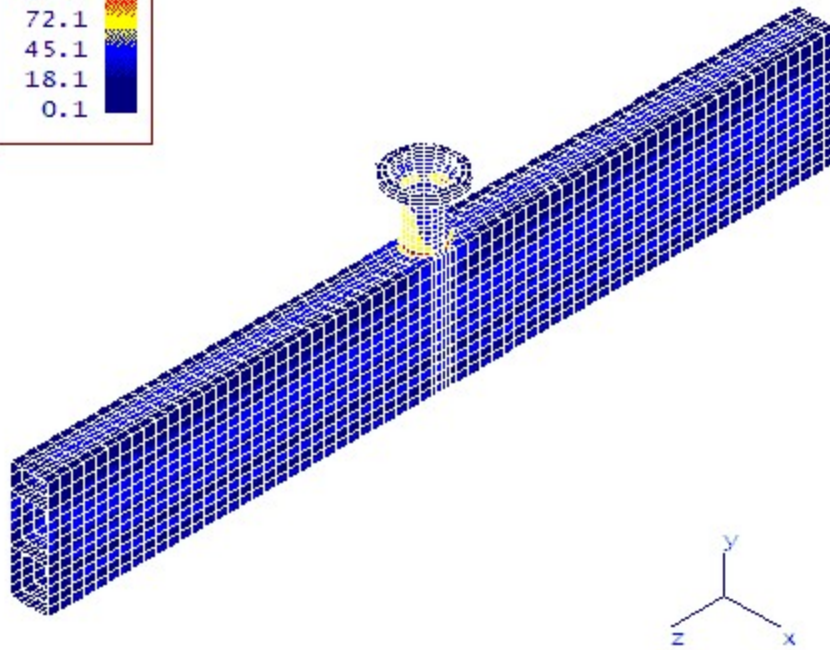
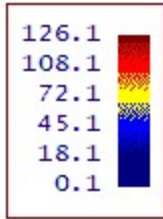

3d 3d(Deformed)

7)  $P1+Pb+Q+F < Sa$  (EXP Outside) Case 2

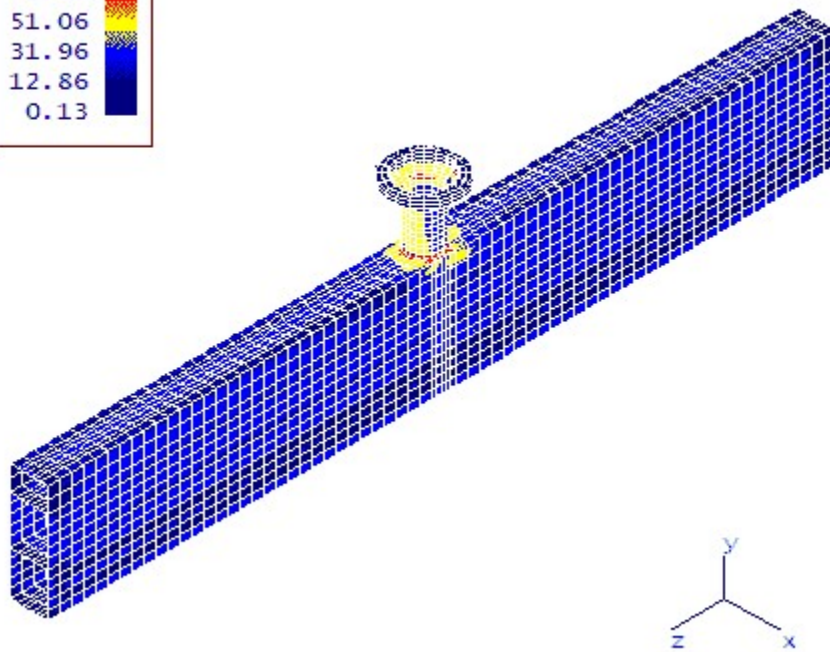
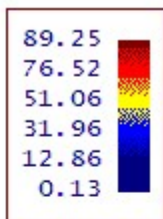

3d 3d(Deformed)

8) Membrane < User (OPE Membrane) Case 2

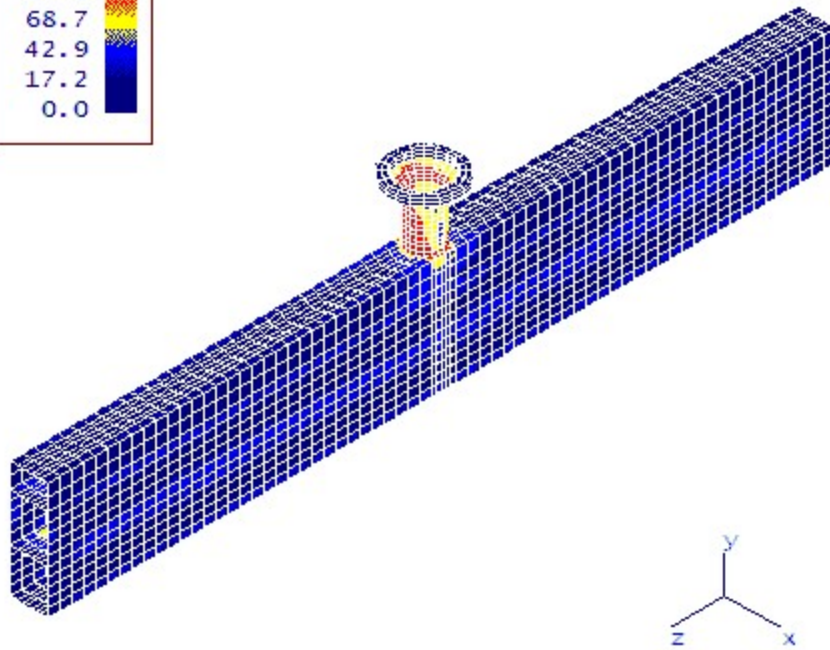
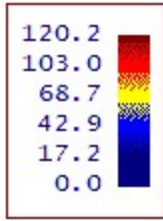

3d 3d(Deformed)

9) Bending < User (OPE Bending) Case 2

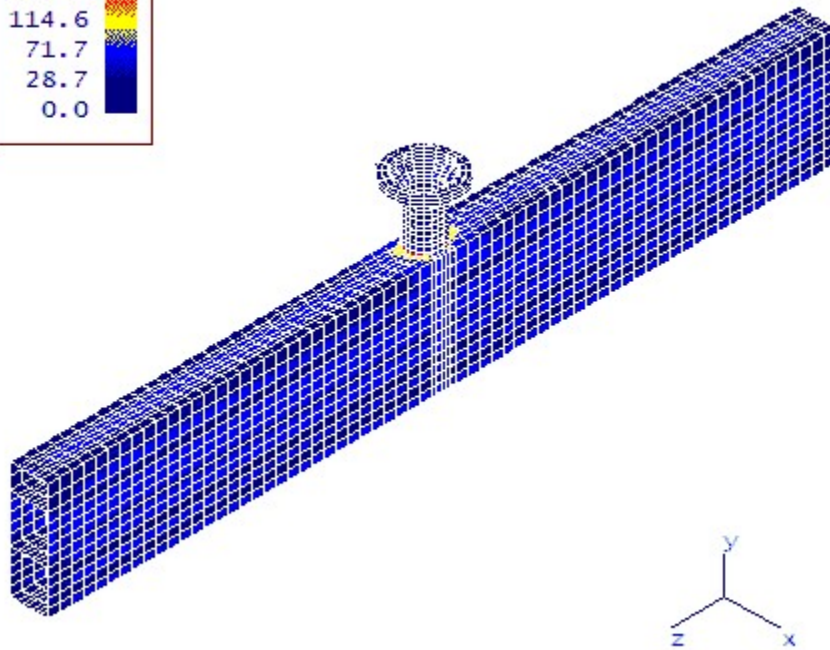
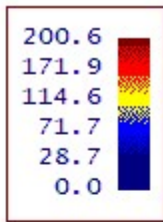

3d 3d(Deformed)

**Tabular Results**

Results were generated with the finite element program FE/Pipe®. Stress results are post-processed in accordance with the rules specified in ASME Section III and ASME Section VIII, Division 2.

Analysis Time Stamp: Sat Jun 01 10:40:50 2024.

- [Model Notes, Tube Results and API Check](#)
- [Load Case Report](#)
- [Solution Data](#)
- [ASME Code Stress Output Plots](#)
- [Stress Results - Notes](#)
- [ASME Overstressed Areas](#)
- [Highest Primary Stress Ratios](#)
- [Highest Secondary Stress Ratios](#)
- [Highest Fatigue Stress Ratios](#)
- [Graphical Results](#)

Model Notes, Tube Results and API Check  
Model Notes, Tube Results and API Check

661PRO 2.0 - API 661 - Air-Cooled Heat Exchanger Nozzle Model

Input Echo:

Notes:

- The centerline of the header box is along the -Z axis.
- Only 1 Nozzle will be modeled at a time. The Nozzle Number Modeled can be seen below.
- User Defined Loads API 661 Check is shown below.
- Sum of ALL Nozzle Loads must not exceed 3\*API Allowable Loads shown in Table 4 according to API 661 2002 paragraph 7.1.10.3.
- Results are given as: Actual Load, Allowable Load, percentage of allowable for API Check in lbs. and ft-lbs. for English Units and N. and N-m for SI Units.

Nozzle Number Modeled : 1  
Top or Bottom Nozzle : Bottom

Analysis Type : User Defined Loads

Nozzle Type : Straight  
Flange Type : Weldneck

Header Box Dimensions:  
Centerline on : Centerline on LEFT Side  
Height : 389.000 mm.  
Width : 140.000 mm.  
Length : 2510.000 mm.

Outboard Thickness : 17.000 mm.  
Tubesheet Side Thickness : 17.000 mm.  
Top Plate Thickness : 17.000 mm.  
Free End Plate Thickness : 17.000 mm.

Header Box Pressure : 2.200 MPa

Header Box Fixed at Centerline

Partition Plates:  
Number of Partition Plates : 2

Partition Plate #1  
Plate Elevation from Bottom : 88.000 mm.  
Plate Thickness : 6.000 mm.

Partition Plate #2  
Plate Elevation from Bottom : 240.000 mm.

Plate Thickness : 6.000 mm.

Nozzle Dimensions:

Distance to CenterLine : 1255.000 mm.  
 Nozzle Outside Diameter : 82.500 mm.  
 Nozzle Thickness : 12.850 mm.  
 Projection to Face of Flange : 200.000 mm.  
 Flange Thickness Used : 17.960 mm.  
 Flange ID : 100.950 mm.  
 Flange Hub Length Used : 26.939 mm.

Weld Size and SCF : 0.000, 1.350

Engineering Details:

Operating Cycles : 7000  
 Occasional Cycles : 0  
 Ambient Temperature : 21.100 deg.  
 Computation Type : Gauss Average

Material Properties

Nozzle:

Cold Allowable Stress : 137.900 MPa  
 Hot Allowable Stress : 137.900 MPa  
 Elastic Modulus : 0.203E+06 MPa  
 Poissons Ratio : 0.300  
 Material ID : 2-Low Alloy Steels  
 Density : 0.768E-04 N /cu. mm.

Header Box:

Cold Allowable Stress : 137.900 MPa  
 Hot Allowable Stress : 137.900 MPa  
 Elastic Modulus : 0.203E+06 MPa  
 Poissons Ratio : 0.300  
 Material ID : 2-Low Alloy Steels  
 Density : 0.768E-04 N /cu. mm.

Tubesheet was not modeled

User Defined Loads:

	Forces [ N ]			Moments [ mm.- N ]		
	FX	FY	FZ	MX	MY	MZ
Weight	3060	3990	3060	450000	720000	450000
Operating	3060	3990	3060	450000	720000	450000
Occasional	0	0	0	0	0	0

No Tube Results

API Check for User Defined Loads

See Notes Above.

Total Nozzle Loads per DOF in [ N ]

FX	:	3060,	6000,	51 %
FY	:	3990,	5070,	79 %
FZ	:	3060,	6000,	51 %
MX	:	450,	1230,	37 %
MY	:	720,	1830,	39 %
MZ	:	450,	1230,	37 %

[Table of Contents](#)

Load Case Report  
 FE/Pipe Version 7.0  
 Released Jul 2014

Jobname: setup2  
 10:37am JUN 1,2024

\$P

Load Case Report

\$X

Inner and outer element temperatures are the same throughout the model. No thermal ratcheting

calculations will be performed.

THE 4 LOAD CASES ANALYZED ARE:

1 WEIGHT ONLY (Wgt Only)

Weight ONLY case run to get the stress range between the installed and the operating states.

/----- Loads in Case 1  
Loads due to Weight

2 SUSTAINED (Wgt+Pr)

Sustained case run to satisfy local primary membrane and bending stress limits.

/----- Loads in Case 2  
Loads due to Weight  
Pressure Case 1

3 OPERATING

Case run to compute the operating stresses used in secondary, peak and range calculations as needed.

/----- Loads in Case 3  
Pressure Case 1  
Loads from (Operating)

4 RANGE (Fatigue Calc Performed)

Case run to get the RANGE of stresses.

/----- Combinations in Range Case 4  
Plus Stress Results from CASE 3  
Minus Stress Results from CASE 1

[Table of Contents](#)

Solution Data

FE/Pipe Version 7.0 Jobname: setup2 \$P  
Released Jul 2014 10:38am JUN 1,2024

Solution Data

Maximum Solution Row Size = 1740  
Number of Nodes = 12063  
Number of Elements = 4107  
Number of Solution Cases = 3

Summation of Loads per Case

Case #	FX	FY	FZ
1	3060.	5575.	3060.
2	3060.	32418.	-97603.
3	3060.	32418.	-97603.

[Table of Contents](#)

ASME Code Stress Output Plots

FE/Pipe Version 7.0 Jobname: setup2 \$P  
Released Jul 2014 10:40am JUN 1,2024

ASME Code Stress Output Plots \$X

1) P1 < 1.5(k)Smh (SUS,Membrane) Case 2

2) Qb < 3(Smh) (SUS,Bending) Case 2

- 3)  $S1+S2+S3 < 4S$  (SUS,S1+S2+S3) Case 2
- 4)  $P1+Pb+Q < 3(Smavg)$  (OPE,Inside) Case 3
- 5)  $P1+Pb+Q < 3(Smavg)$  (OPE,Outside) Case 3
- 6) Membrane  $< User$  (OPE,Membrane) Case 3
- 7) Bending  $< User$  (OPE,Bending) Case 3
- 8)  $P1+Pb+Q < 3(Smavg)$  (EXP,Inside) Case 4
- 9)  $P1+Pb+Q < 3(Smavg)$  (EXP,Outside) Case 4
- 10)  $P1+Pb+Q+F < Sa$  (EXP,Inside) Case 4
- 11)  $P1+Pb+Q+F < Sa$  (EXP,Outside) Case 4

[Table of Contents](#)

---

Stress Results - Notes

FE/Pipe Version 7.0                      Jobname: setup2                      \$P  
Released Jul 2014                      10:40am JUN 1,2024

Stress Results - Notes

- Results in this analysis were generated using the finite element solution method.
- Using pre 07 ASME Section VIII Division 2
- Assume free end displacements of attached pipe are secondary loads within limits of nozzle reinforcement.
- Use Stress Intensity (TRESCA).
- $S1+S2+S3$  evaluation omitted from operating stress. Include  $S1+S2+S3$  evaluation in primary case evaluation. Assume bending stress not local primary for  $S1+S2+S3$ .
- Use local tensor values for averaged and not averaged stresses.
  - PRIMARY STRESSES are similar to the B31 code "sustained" stresses. Primary stresses contain the effects due to weight, pressure and other sustained loads. The primary limit for this stress is based on collapse of the local cross section or excessive local strain.
  - SECONDARY (PL+PB+Q) STRESS has no direct equal in a B31 code. This stress requirement is intended to insure that significant inelastic behavior only occurs for the first few loading cycles, and only over a fairly small region of the model. "Small" is on the order of the square root of  $Rt$ , where (R) is the radius of the header and (t) is the thickness of the header. Secondary stresses do not include the effect of peak stress concentration factors such as occur at fillets, welds or notches.
  - PEAK STRESSES are equivalent to the B31 code "expansion" stresses. In the peak stress report, the user will find the equivalent B31 allowable computed from:  $f[1.25(Sc+Sh)]$ .
  - The LOCAL STRESS calculations performed herein are in accordance with ASME VIII Div 2, Part 5, elastic calculations, and ASME Section III Subsection NB. These methods have been used extensively in the nuclear piping industry, and have been shown to be in consistent agreement with the B31 piping codes when the simplifying assumptions made in the B31 codes are employed.
  - The B31 Code Stress Calculations performed herein are in accordance with the method outlined in NUREG/CR-3243 and (ORNL/Sub/82-22252/1). This paper shows the relationship between the fatigue evaluation methods used in the B31 codes and the class 1,2 and 3 nuclear piping codes.



## Circ Plate for Plate # 4

Pl	1.5(k)Smh	Primary Membrane Load Case 2
26	207	Sect VIII Ref: AD-140, 4-112(i), 4-133,
MPa	MPa	Fig. 4-130.1, Table 4-120.1
		Plot Reference:
12%		1) Pl < 1.5(k)Smh (SUS,Membrane) Case 2

## Long Plate for Plate # 4

Pl	1.5(k)Smh	Primary Membrane Load Case 2
6	207	Sect VIII Ref: AD-140, 4-112(i), 4-133,
MPa	MPa	Fig. 4-130.1, Table 4-120.1
		Plot Reference:
2%		1) Pl < 1.5(k)Smh (SUS,Membrane) Case 2

[Table of Contents](#)

## Highest Secondary Stress Ratios

FE/Pipe Version 7.0                      Jobname: setup2                      \$P  
Released Jul 2014                      10:40am JUN 1,2024

## Highest Secondary Stress Ratios

\$X

## Circ Plate for Plate # 1

Pl+Pb+Q	3(Smavg)	Primary+Secondary (Inner) Load Case 3
67	414	Sect VIII Ref: 4-120(b)(4), 4-134, 4-136.6,
MPa	MPa	Fig. 4-130.1(Note 1)
		Plot Reference:
16%		4) Pl+Pb+Q < 3(Smavg) (OPE,Inside) Case 3

## Long Plate for Plate # 1

Pl+Pb+Q	3(Smavg)	Primary+Secondary (Outer) Load Case 3
82	414	Sect VIII Ref: 4-120(b)(4), 4-134, 4-136.6,
MPa	MPa	Fig. 4-130.1(Note 1)
		Plot Reference:
19%		5) Pl+Pb+Q < 3(Smavg) (OPE,Outside) Case 3

## Circ Plate for Plate # 2

Pl+Pb+Q	3(Smavg)	Primary+Secondary (Inner) Load Case 3
65	414	Sect VIII Ref: 4-120(b)(4), 4-134, 4-136.6,
MPa	MPa	Fig. 4-130.1(Note 1)
		Plot Reference:
15%		4) Pl+Pb+Q < 3(Smavg) (OPE,Inside) Case 3

## Circ Plate for Plate # 3

Pl+Pb+Q	3(Smavg)	Primary+Secondary (Inner) Load Case 3
159	414	Sect VIII Ref: 4-120(b)(4), 4-134, 4-136.6,
MPa	MPa	Fig. 4-130.1(Note 1)
		Plot Reference:
38%		4) Pl+Pb+Q < 3(Smavg) (OPE,Inside) Case 3

## Circ Plate for Plate # 4

Pl+Pb+Q	3(Smavg)	Primary+Secondary (Inner) Load Case 3
56	414	Sect VIII Ref: 4-120(b)(4), 4-134, 4-136.6,
MPa	MPa	Fig. 4-130.1(Note 1)
		Plot Reference:
13%		4) Pl+Pb+Q < 3(Smavg) (OPE,Inside) Case 3

## Long Plate for Plate # 4

Pl+Pb+Q	3(Smavg)	Primary+Secondary (Outer) Load Case 3
10	414	Sect VIII Ref: 4-120(b)(4), 4-134, 4-136.6,
MPa	MPa	Fig. 4-130.1(Note 1)
		Plot Reference:

2%

5) Pl+Pb+Q &lt; 3(Smavg) (OPE,Outside) Case 3

[Table of Contents](#)

## Highest Fatigue Stress Ratios

FE/Pipe Version 7.0

Jobname: setup2

\$P

Released Jul 2014

10:40am JUN 1,2024

## Highest Fatigue Stress Ratios

\$X

## Circ Plate for Plate # 1

Pl+Pb+Q+F	Sa	Primary+Secondary+Peak (Inner) Load Case 4
32	290	Stress Concentration Factor = 1.000
MPa	MPa	Strain Concentration Factor = 1.000
		Cycles Allowed for this Stress = 1.0000E11
11%		"B31" Fatigue Stress Allowable = 344.8
		Mark1 Fatigue Stress Allowable = 287.5
		WRC 474 Mean Cycles to Failure = 17,652,156.
		WRC 474 99% Probability Cycles = 4,100,752.
		WRC 474 95% Probability Cycles = 5,693,378.
		BS5500 Allowed Cycles(Curve F) = 2,541,689.
		Membrane-to-Bending Ratio = 0.330
		Bending-to-PL+PB+Q Ratio = 0.752
		Sect VIII Ref: 4-112(1)(2),Fig.4-130.1,4-135
		Plot Reference:
		10) Pl+Pb+Q+F < Sa (EXP,Inside) Case 4

## Long Plate for Plate # 1

Pl+Pb+Q+F	Sa	Primary+Secondary+Peak (Outer) Load Case 4
20	290	Stress Concentration Factor = 1.000
MPa	MPa	Strain Concentration Factor = 1.000
		Cycles Allowed for this Stress = 1.0000E11
6%		"B31" Fatigue Stress Allowable = 344.8
		Mark1 Fatigue Stress Allowable = 287.5
		WRC 474 Mean Cycles to Failure = 76,564,944.
		WRC 474 99% Probability Cycles = 17,786,732.
		WRC 474 95% Probability Cycles = 24,694,636.
		BS5500 Allowed Cycles(Curve F) = 11,041,011.
		Membrane-to-Bending Ratio = 0.423
		Bending-to-PL+PB+Q Ratio = 0.703
		Sect VIII Ref: 4-112(1)(2),Fig.4-130.1,4-135
		Plot Reference:
		11) Pl+Pb+Q+F < Sa (EXP,Outside) Case 4

## Circ Plate for Plate # 2

Pl+Pb+Q+F	Sa	Primary+Secondary+Peak (Inner) Load Case 4
32	290	Stress Concentration Factor = 1.000
MPa	MPa	Strain Concentration Factor = 1.000
		Cycles Allowed for this Stress = 1.0000E11
11%		"B31" Fatigue Stress Allowable = 344.8
		Mark1 Fatigue Stress Allowable = 287.5
		WRC 474 Mean Cycles to Failure = 17,649,554.
		WRC 474 99% Probability Cycles = 4,100,147.
		WRC 474 95% Probability Cycles = 5,692,538.
		BS5500 Allowed Cycles(Curve F) = 2,542,080.
		Membrane-to-Bending Ratio = 0.330
		Bending-to-PL+PB+Q Ratio = 0.752
		Sect VIII Ref: 4-112(1)(2),Fig.4-130.1,4-135
		Plot Reference:
		10) Pl+Pb+Q+F < Sa (EXP,Inside) Case 4

## Circ Plate for Plate # 3

Pl+Pb+Q+F	Sa	Primary+Secondary+Peak (Inner) Load Case 4
21	290	Stress Concentration Factor = 1.000
MPa	MPa	Strain Concentration Factor = 1.000
		Cycles Allowed for this Stress = 1.0000E11
7%		"B31" Fatigue Stress Allowable = 344.8
		Mark1 Fatigue Stress Allowable = 287.5
		WRC 474 Mean Cycles to Failure = 83,741,728.
		WRC 474 99% Probability Cycles = 19,453,966.
		WRC 474 95% Probability Cycles = 27,009,382.

BS5500 Allowed Cycles(Curve F) = 9,217,872.  
 Membrane-to-Bending Ratio = 0.316  
 Bending-to-PL+PB+Q Ratio = 0.760  
 Sect VIII Ref: 4-112(1) (2), Fig.4-130.1,4-135  
 Plot Reference:  
 10) Pl+Pb+Q+F < Sa (EXP,Inside) Case 4

## Circ Plate for Plate # 4

Pl+Pb+Q+F	Sa	Primary+Secondary+Peak (Inner) Load Case 4
7	290	Stress Concentration Factor = 1.000
MPa	MPa	Strain Concentration Factor = 1.000
		Cycles Allowed for this Stress = 1.0000E11
2%		"B31" Fatigue Stress Allowable = 344.8
		Mark1 Fatigue Stress Allowable = 287.5
		WRC 474 Mean Cycles to Failure = 2.9154E9
		WRC 474 99% Probability Cycles = 6.7728E8
		WRC 474 95% Probability Cycles = 9.4031E8
		BS5500 Allowed Cycles(Curve F) = 3.0971E9
		Membrane-to-Bending Ratio = 1.660
		Bending-to-PL+PB+Q Ratio = 0.376
		Sect VIII Ref: 4-112(1) (2), Fig.4-130.1,4-135
		Plot Reference:
		10) Pl+Pb+Q+F < Sa (EXP,Inside) Case 4

## Long Plate for Plate # 4

Pl+Pb+Q+F	Sa	Primary+Secondary+Peak (Inner) Load Case 4
2	290	Stress Concentration Factor = 1.000
MPa	MPa	Strain Concentration Factor = 1.000
		Cycles Allowed for this Stress = 1.0000E11
0%		"B31" Fatigue Stress Allowable = 344.8
		Mark1 Fatigue Stress Allowable = 287.5
		WRC 474 Mean Cycles to Failure = 7.6867E10
		WRC 474 99% Probability Cycles = 1.7857E10
		WRC 474 95% Probability Cycles = 2.4792E10
		BS5500 Allowed Cycles(Curve F) = 9.3069E11
		Membrane-to-Bending Ratio = 2.391
		Bending-to-PL+PB+Q Ratio = 0.295
		Sect VIII Ref: 4-112(1) (2), Fig.4-130.1,4-135
		Plot Reference:
		10) Pl+Pb+Q+F < Sa (EXP,Inside) Case 4

## Circ Plate for Plate # 5

Pl+Pb+Q+F	Sa	Primary+Secondary+Peak (Inner) Load Case 4
32	290	Stress Concentration Factor = 1.000
MPa	MPa	Strain Concentration Factor = 1.000
		Cycles Allowed for this Stress = 1.0000E11
11%		"B31" Fatigue Stress Allowable = 0.0
		Mark1 Fatigue Stress Allowable = 287.5
		WRC 474 Mean Cycles to Failure = 36,376,952.
		WRC 474 99% Probability Cycles = 8,450,688.
		WRC 474 95% Probability Cycles = 11,732,729.
		BS5500 Allowed Cycles(Curve F) = 2,542,065.
		Membrane-to-Bending Ratio = 0.330
		Bending-to-PL+PB+Q Ratio = 0.752
		Sect VIII Ref: 4-112(1) (2), Fig.4-130.1,4-135
		Plot Reference:
		10) Pl+Pb+Q+F < Sa (EXP,Inside) Case 4

[Table of Contents](#)

*Finite Element Model*

- [Finite Element Model](#)
- [1\)  \$PI < 1.5\(k\)Smh\$  \(SUS Membrane\) Case 2](#)
- [2\)  \$Qb < 3\(Smh\)\$  \(SUS Bending\) Case 2](#)
- [3\)  \$S1+S2+S3 < 4S\$  \(SUS  \$S1+S2+S3\$ \) Case 2](#)
- [4\)  \$PI+Pb+Q < 3\(Smavg\)\$  \(OPE Inside\) Case 3](#)
- [5\)  \$PI+Pb+Q < 3\(Smavg\)\$  \(OPE Outside\) Case 3](#)
- [6\) Membrane < User \(OPE Membrane\) Case 3](#)
- [7\) Bending < User \(OPE Bending\) Case 3](#)
- [8\)  \$PI+Pb+Q < 3\(Smavg\)\$  \(EXP Inside\) Case 4](#)
- [9\)  \$PI+Pb+Q < 3\(Smavg\)\$  \(EXP Outside\) Case 4](#)
- [10\)  \$PI+Pb+Q+F < Sa\$  \(EXP Inside\) Case 4](#)
- [11\)  \$PI+Pb+Q+F < Sa\$  \(EXP Outside\) Case 4](#)

Finite Element Model

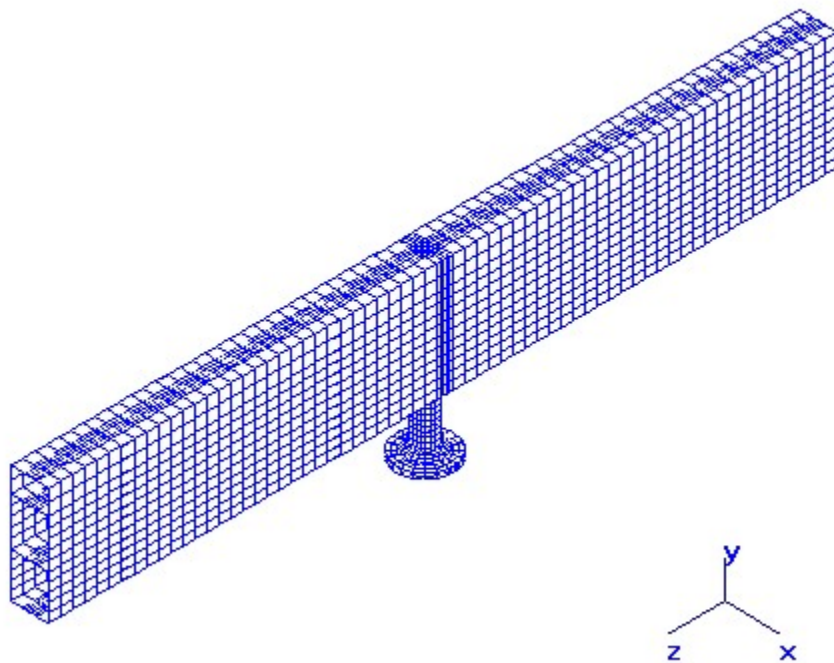

3d

1)  $P1 < 1.5(k)Smh$  (SUS Membrane)\_Case 2

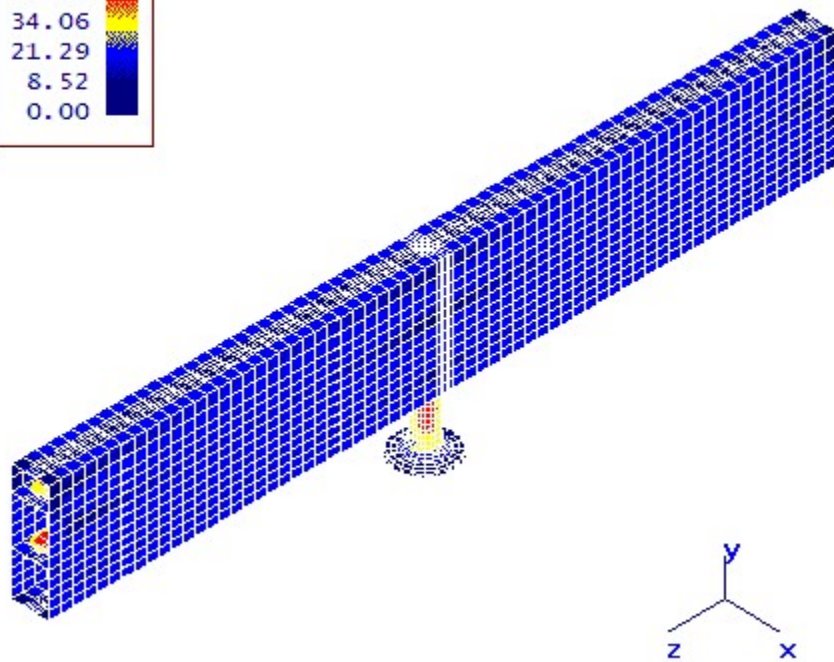
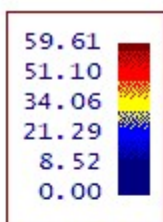

3d

3d(Deformed)

2)  $Q_b < 3(Smh)$  (SUS Bending) Case 2

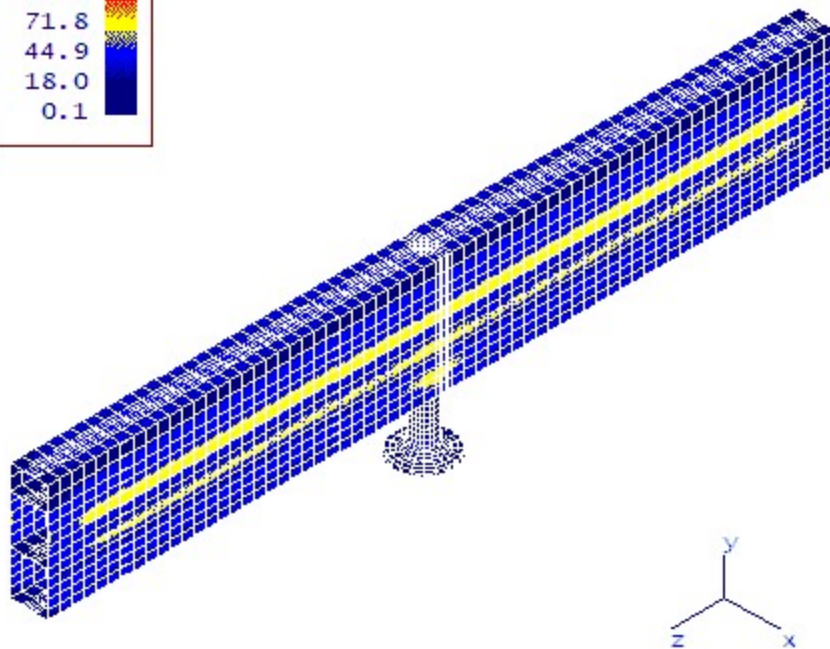
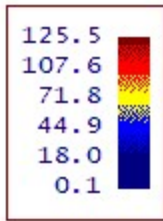

3d 3d(Deformed)

3)  $S1+S2+S3 < 4S$  (SUS  $S1+S2+S3$ ) Case 2

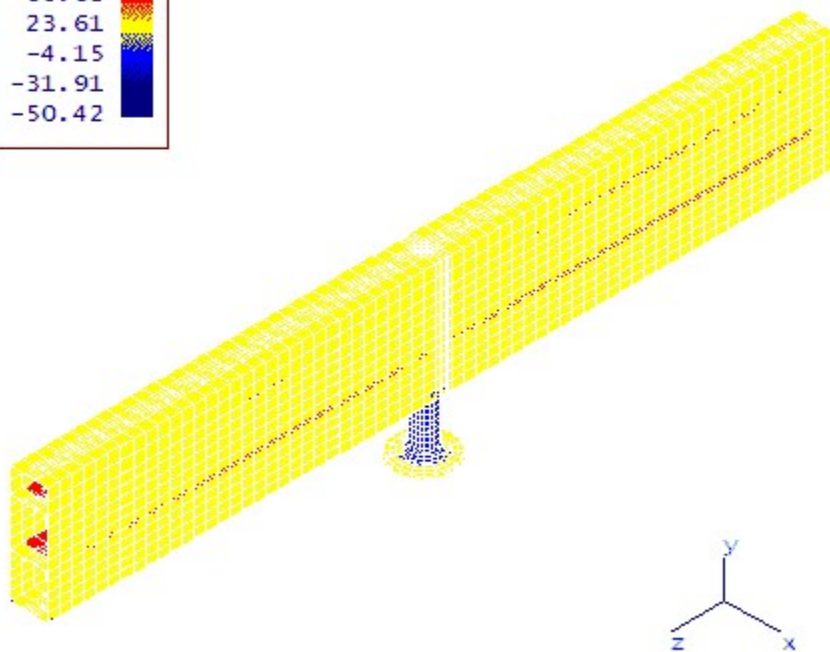
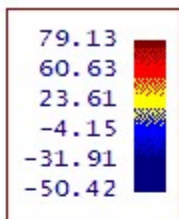

3d 3d(Deformed)

4)  $P1+Pb+Q < 3(Smavg)$  (OPE Inside) Case 3

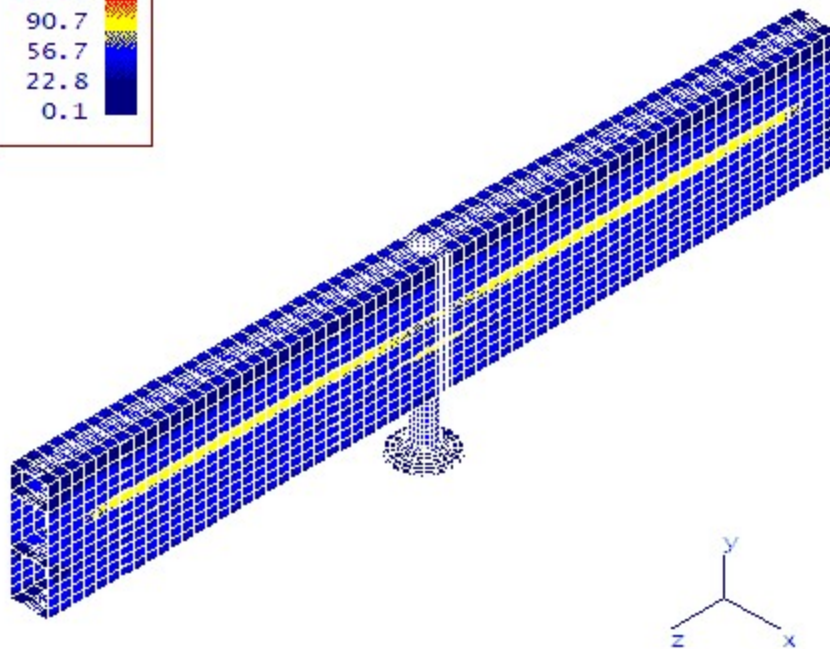
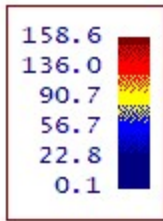

3d 3d(Deformed)

5)  $P1+Pb+Q < 3(Smavg)$  (OPE Outside) Case 3

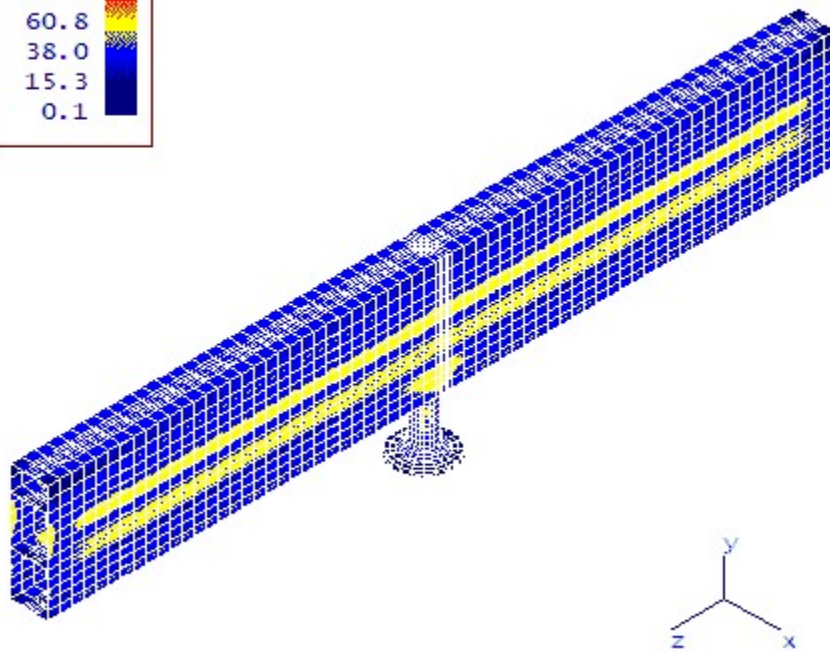
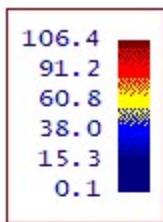

3d 3d(Deformed)

6) Membrane < User (OPE Membrane) Case 3

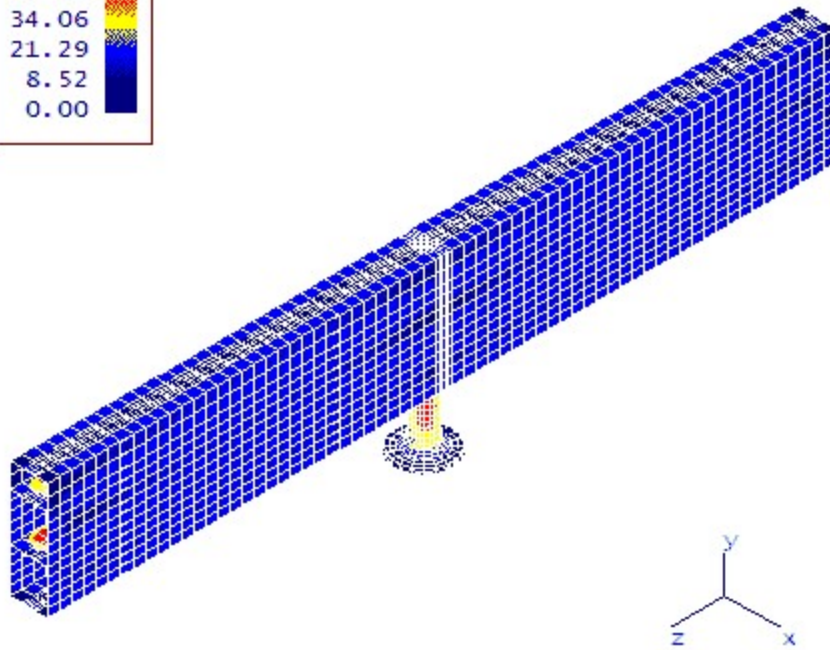
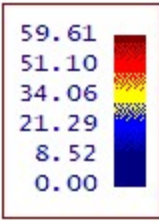

3d 3d(Deformed)

7) Bending < User (OPE Bending) Case 3

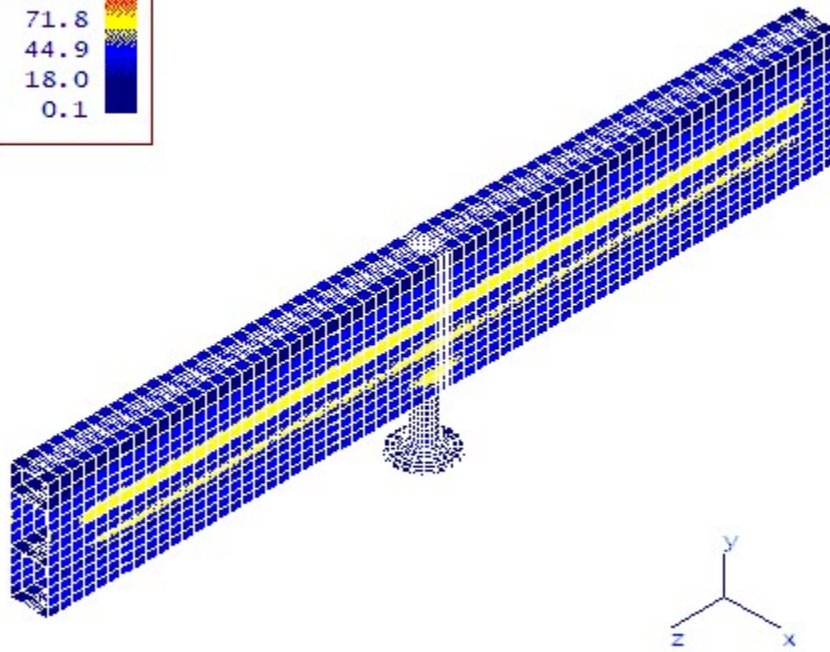
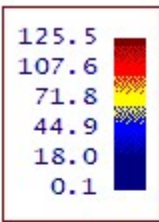

3d 3d(Deformed)

8)  $P1+Pb+Q < 3(Smavg)$  (EXP Inside) Case 4

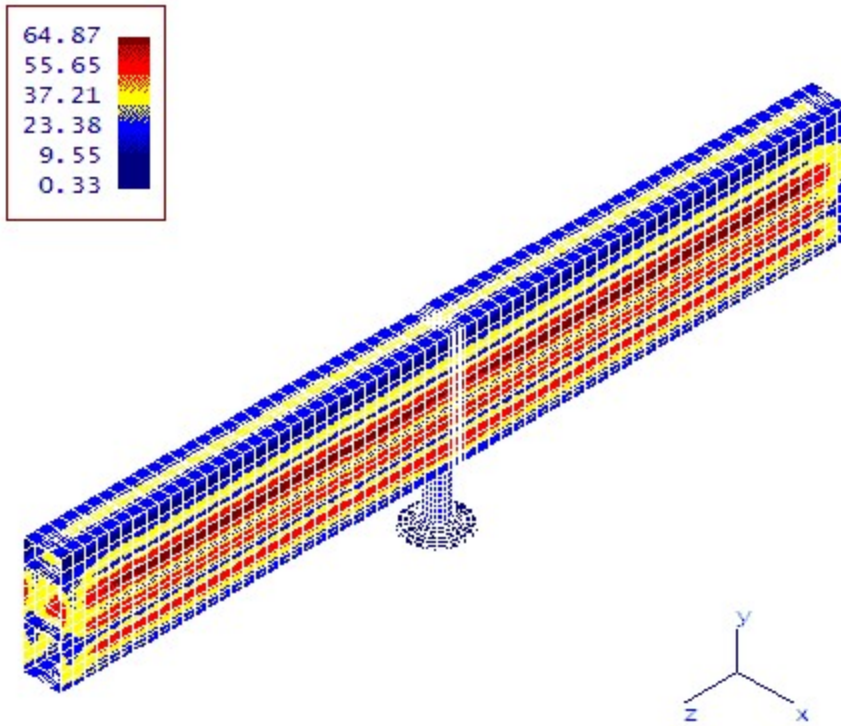

3d

9)  $P1+Pb+Q < 3(Smavg)$  (EXP Outside) Case 4

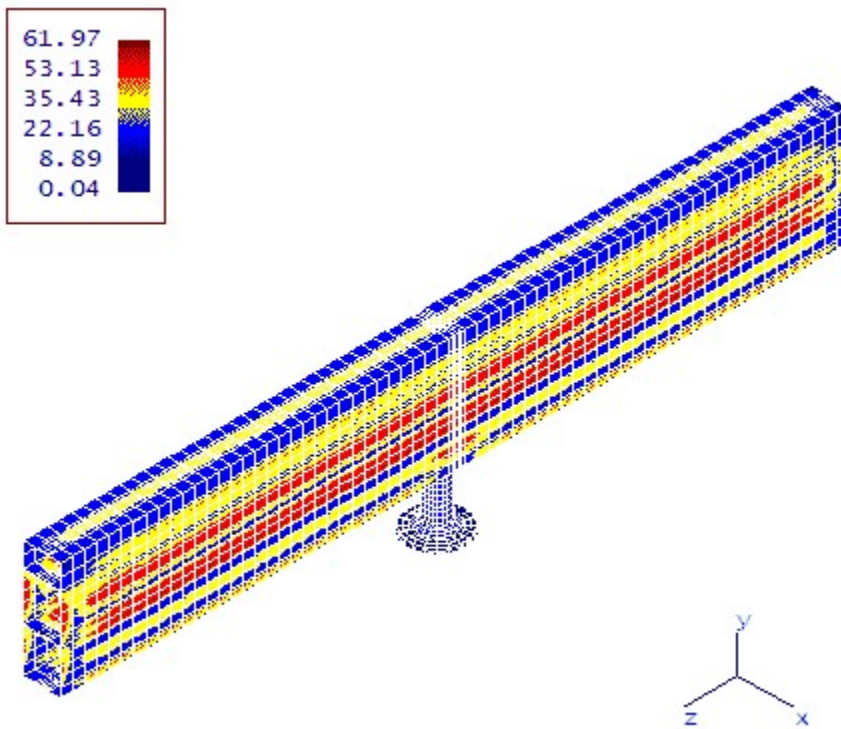

3d

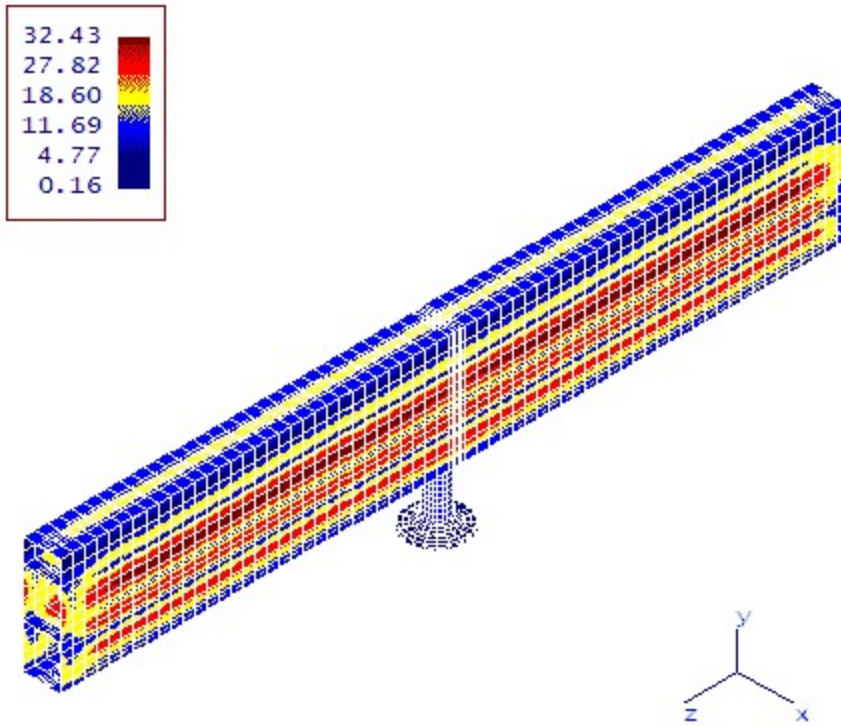
10)  $P1+Pb+Q+F < Sa$  (EXP Inside) Case 4

3d

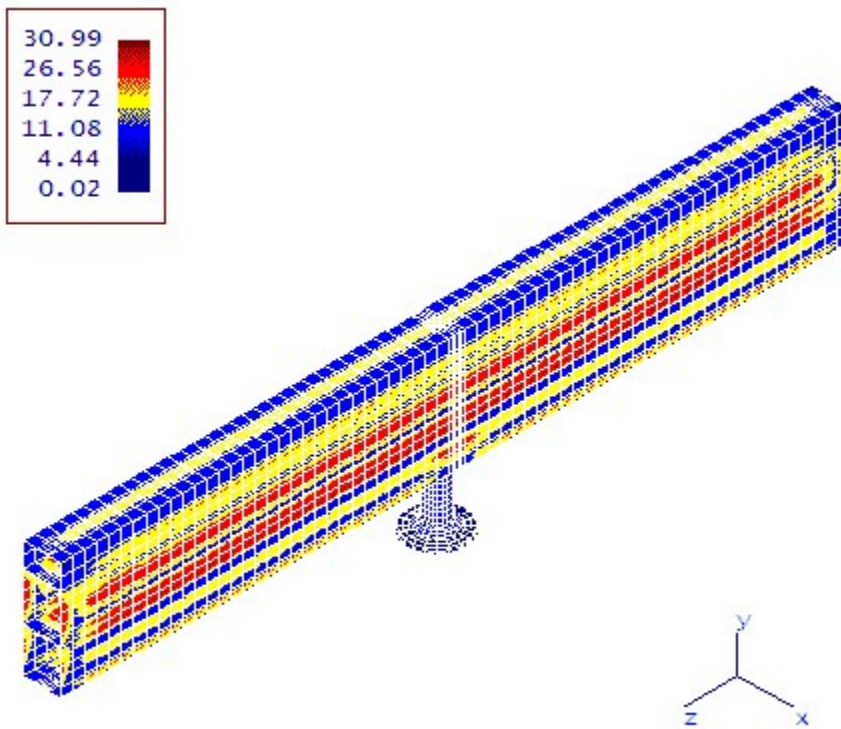
11)  $P1+Pb+Q+F < Sa$  (EXP Outside) Case 4

3d

## **2. Stationary & rear header Box code calc in Hydrotest**

**Input Echo, COMPONENT 1, Description: FRONT**

```

Figure Number Analyzed                A8

Design Internal Pressure                P          37.7000  bars
Design Temperature                    Temp       120.0000  C

VESSEL MATERIAL DATA:
Material Specification                SA-516 70
Shell Allowable Stress at Design Temp S          212.0000  N./mm^2
Shell Allowable Stress at Ambient    SA          212.0000  N./mm^2
Shell Yield Stress at Design Temperature Sy       235.9761  N./mm^2

SHORT-SIDE VESSEL DATA:
Short-side Length Dimension          H          100.0000  mm.
Minimum Thickness of Short-side Plates t1         20.0000  mm.
Mid-side Joint Efficiency on Short-side E          0.8500
Corner Joint Efficiency on Short-side EC          0.8500

LONG-SIDE VESSEL DATA:
Long-side Length Dimension           h          140.0000  mm.
Minimum Thickness of Long-side Plates t2         20.0000  mm.
Mid-side Joint Efficiency on Long-side E          0.8500

ADDITIONAL VESSEL DATA:
Minimum Thickness of End Plate       t5         20.0000  mm.
C-Factor for End Plate              Cf_Epl     0.2000
Corrosion Allowance of Shell        CA          3.0000  mm.

Long-side Plate # 1,
  Pitch Distance                     p          69.8500  mm.
  # 1: Hole Diameter                 d0         36.5000  mm.
  Hole Depth                         T0          1.7000  mm.
  # 2: Hole Diameter                 d1         28.6000  mm.
  Hole Depth                         T1          18.3000  mm.
Long-side Plate # 2,
  Pitch Distance                     p          69.8500  mm.
  Uniform Hole Diameter              d0         25.7000  mm.
  Depth of Holes                    T0          20.0000  mm.

STAY PLATE MATERIAL DATA:
Stay Material Specification          SA-516 70
Stay Allowable Stress at Design Temp Sr          212.0000  N./mm^2
Stay Allowable Stress at Ambient    SA          212.0000  N./mm^2
Stay Yield Stress at Design Temp    Sy          235.9761  N./mm^2

STAY PLATE DATA:
Minimum Thickness of Stay            t3         12.0000  mm.
Minimum Thickness of Stay            t4         12.0000  mm.
The Stay(s) Are Not Welded to the End Plate
Corrosion Allowance of Stay         CAS          3.0000  mm.
    
```

**REV.03**

**Rectangular Vessel Results, Item number 1, Desc: FRONT  
ASME Code, Section VIII, Division 1, 2017 App. 13**

**Ligament Efficiency Calculations (Section 13-6, Equations (1)-(6)):**

**Short-side 1 Calculations**

Membrane Ligament Efficiency [Em]:  
= 0.850

Bending Ligament Efficiency [Eb]:  
= 0.850

Dist from Neutral axis of c/s to inside surface of the vessel [Ci]:  
= t1 - CA / 2  
= 20.000 - 3.000 / 2  
= 8.500 mm.

FileName : HYDROTEST-FRONT-rev.02

Rectves Analysis : FRONT

Item: 1 4:03p Jul 28,2024

Dist from Neutral axis of c/s to extreme outside surface of the section [Co]:

$$\begin{aligned}
 &= -(t_1 - CA) / 2 \\
 &= -(20.000 - 3.000) / 2 \\
 &= -8.500 \text{ mm.}
 \end{aligned}$$

**Short-side 2 Calculations**

Membrane Ligament Efficiency [Em]:

$$= 0.850$$

Bending Ligament Efficiency [Eb]:

$$= 0.850$$

Dist from Neutral axis of c/s to inside surface of the vessel [Ci]:

$$\begin{aligned}
 &= t_1 - CA / 2 \\
 &= 20.000 - 3.000 / 2 \\
 &= 8.500 \text{ mm.}
 \end{aligned}$$

Dist from Neutral axis of c/s to extreme outside surface of the section [Co]:

$$\begin{aligned}
 &= -(t_1 - CA) / 2 \\
 &= -(20.000 - 3.000) / 2 \\
 &= -8.500 \text{ mm.}
 \end{aligned}$$

**Long-side 1 Calculations**

Effective Diameter [De]:

$$\begin{aligned}
 &= (d_0 * T_0 + d_1 * T_1 + d_2 * T_2) / (t_1 - CA) \\
 &= (36.50 * 1.70 + 28.60 * 15.30 + 0.00 * 0.00) / \\
 &\quad (20.00 - 3.00) \\
 &= 29.390 \text{ mm.}
 \end{aligned}$$

Membrane Ligament Efficiency [Em]:

$$\begin{aligned}
 &= \text{Pitch} - De / \text{Pitch} \\
 &= 69.850 - 29.390 / 69.850 \\
 &= 0.579
 \end{aligned}$$

Dist from Neutral axis of c/s to extreme fibers [Ci &amp; Co]:

**Calculation of Xbar:**

$$\begin{aligned}
 &= ((b_0 * T_0 * (T_0/2 + T_1 + T_2)) + (b_1 * T_1 * \\
 &\quad (T_1/2 + T_2)) + (b_2 * T_2 * (T_2/2))) / \\
 &\quad (b_0 * T_0 + b_1 * T_1 + b_2 * T_2) \\
 &= ((1.31 * 1.70 * (1.70 / 2 + 15.30 + 0.00)) + (1.62 * 15.30 * \\
 &\quad (15.30 / 2 + 0.00)) + (2.75 * 0.00 * (0.00 / 2))) / \\
 &\quad (1.31 * 1.70 + 1.62 * 15.30 + 2.75 * 0.00) \\
 &= 8.351 \text{ mm.}
 \end{aligned}$$

Dist from Neutral axis of c/s to inside surface of the vessel [Ci]:

 $C_i = X_{bar}$ 

$$= 8.351 \text{ mm.}$$

Dist from Neutral axis of c/s to extreme outside surface of the section [Co]:

$$\begin{aligned}
 &= -(t - CA - X_{bar}) \\
 &= -(20.000 - 3.000 - 8.351) \\
 &= -8.649 \text{ mm.}
 \end{aligned}$$

Moment of Inertia (Section 13-6, Equation (5)) [I]:

$$= 0.063 \text{ cm}^4$$

Effective Diameter [De]:

$$\begin{aligned}
 &= \text{Pitch} - ((6 * I) / ((t - CA)^2 * (-Co))) \\
 &= 69.85 - ((6 * 0.06) / ((20.00 - 3.00)^2 * (8.65))) \\
 &= 31.244 \text{ mm.}
 \end{aligned}$$

Bending Ligament Efficiency [Eb]:

$$\begin{aligned}
 &= \text{Pitch} - De / \text{Pitch} \\
 &= 69.850 - 31.244 / 69.850 \\
 &= 0.553
 \end{aligned}$$

**Long-side 2 Calculations**

Effective Diameter [De]: 25.700 mm.

Membrane Ligament Efficiency [Em]:  
 = Pitch - De / Pitch  
 = 69.850 - 25.700 / 69.850  
 = 0.632

Bending Ligament Efficiency [Eb]:  
 As diameter holes are uniform Eb = Em  
 = 0.632

Dist from Neutral axis of c/s to inside surface of the vesssel [Ci]:  
 = t1 - CA / 2  
 = 20.000 - 3.000 / 2  
 = 8.500 mm.

Dist from Neutral axis of c/s to extreme outside surface of the section [Co]:  
 = -( t1 - CA ) / 2  
 = -( 20.000 - 3.000 ) / 2  
 = -8.500 mm.

**Ligament Efficiency Calculations (Section 13-6, Equations (1)-(6)):**

	Em	Eb	Ci	Co
Short-side 1	0.850	0.850	8.500	-8.500
2	0.850	0.850	8.500	-8.500
Long-side 1	0.579	0.553	8.351	-8.649
2	0.632	0.632	8.500	-8.500

**Moment of Inertia of a Strip of the Vessel Wall:**

Thickness t1, I1 = 0.0409 cm\*\*4  
 Thickness t2, I2 = 0.0409 cm\*\*4

**Rectangular Vessel Parameters:**

Alpha = H / h = 0.7260  
 K = (I2/I1)\*Alpha = 0.7260

**Membrane Stress Calculations per Section 13-9**

**Membrane Stresses at Short-side 1**

Membrane Stress at Short-side 1 [Sms]:  
 = P \* h / ( 2 \* t1 ) \* { 3 - [ ( 6 + K \* ( 11 - alpha^2 ) / ( 3 + 5 \* K ) ) ] }  
 = 37.70 \* 146.00 / ( 2 \* 17.00 ) \* { 3 - [ ( 6 + 0.73 \* ( 11 - 0.73^2 ) / ( 3 + 5 \* 0.73 ) ) ] }  
 = 15.35 N./mm^2

**Membrane Stresses at Short-side 2**

Membrane Stress at Short-side 2 [Sms]:  
 = P \* h / ( 2 \* t1 ) \* { 3 - [ ( 6 + K \* ( 11 - alpha^2 ) / ( 3 + 5 \* K ) ) ] }  
 = 37.70 \* 146.00 / ( 2 \* 17.00 ) \* { 3 - [ ( 6 + 0.73 \* ( 11 - 0.73^2 ) / ( 3 + 5 \* 0.73 ) ) ] }  
 = 15.35 N./mm^2

**Membrane Stresses at Long-side 1**

Membrane Stress at Long-side 1 at A [Sml]:  
 = P \* H / 2 \* t2  
 = 37.70 \* 106.00 / 2 \* 17.00  
 = 11.75 N./mm^2

If Em( 0.579 ) < E( 0.850 ) and Eb( 0.553 ) < E( 0.850 ) then  
 Sml = Sml / Em  
 = 11.75 / 0.58

$$= 20.29 \text{ N./mm}^2$$

**Membrane Stresses at Long-side 2**

Membrane Stress at Long-side 2 at A [Sml]:

$$= P * H / 2 * t^2$$

$$= 37.70 * 106.00 / 2 * 17.00$$

$$= 11.75 \text{ N./mm}^2$$

If  $E_m(0.632) < E(0.850)$  and  $E_b(0.632) < E(0.850)$  then

$$S_{ml} = S_{ml} / E_m$$

$$= 11.75 / 0.63$$

$$= 18.60 \text{ N./mm}^2$$

**Membrane Stresses at Stay Plate**

Membrane Stress at Stay Plate [t3]:

$$= P * h / ( 2 * t^3 ) * [ ( 6 + K * ( 11 - \alpha^2 ) / ( 3 + 5 * K ) ) ]$$

$$= 37.70 * 146.00 / ( 2 * 6.00 ) * [ ( 6 + 0.73 * ( 11 - 0.73^2 ) / ( 3 + 5 * 0.73 ) ) ]$$

$$= 94.12 \text{ N./mm}^2$$

Membrane Stress at Stay Plate [t4]:

$$= P * h / ( 2 * t^4 ) * [ ( 6 + K * ( 11 - \alpha^2 ) / ( 3 + 5 * K ) ) ]$$

$$= 37.70 * 146.00 / ( 2 * 6.00 ) * [ ( 6 + 0.73 * ( 11 - 0.73^2 ) / ( 3 + 5 * 0.73 ) ) ]$$

$$= 94.12 \text{ N./mm}^2$$

**MEMBRANE STRESSES: Membrane Stress Calculations per Section 13-9, Equations (13-15). (N./mm<sup>2</sup>) :**

STRESS LOCATIONS	Actual	Allowable
Short-side 1	15.35	180.20
Short-side 2	15.35	180.20
Short-side Corner	15.35	180.20
Long-side 1 at A	20.29	212.00
Long-side 2 at A	18.60	212.00
Long-side Corner	11.75	180.20
Stay Plate (t3)	94.12	212.00
Stay Plate (t4)	94.12	212.00

**Bending Stress Calculations per Section 13-9**

**Bending Stresses at Short-side 1**

Bending Stress at Short-side 1 at N Inner[SbsNi]:

$$= P * c / ( 24 * I_1 ) * [ -3 * H^2 + 2 * h^2 * ( ( 3 + 5 * \alpha^2 * K ) / ( 3 + 5 * K ) ) ]$$

$$= 37.70 * 8.50 / ( 24 * 0.04 ) * [ -3 * 106.00^2 + 2 * 146.00^2 * ( ( 3 + 5 * 0.73^2 * 0.73 ) / ( 3 + 5 * 0.73 ) ) ]$$

$$= -6.89 \text{ N./mm}^2$$

Bending Stress at Short-side 1 at N Outer[SbsNo]:

$$= P * c / ( 24 * I_1 ) * [ -3 * H^2 + 2 * h^2 * ( ( 3 + 5 * \alpha^2 * K ) / ( 3 + 5 * K ) ) ]$$

$$= 37.70 * -8.50 / ( 24 * 0.04 ) * [ -3 * 106.00^2 + 2 * 146.00^2 * ( ( 3 + 5 * 0.73^2 * 0.73 ) / ( 3 + 5 * 0.73 ) ) ]$$

$$= 6.89 \text{ N./mm}^2$$

Bending Stress at Short-side 1 at Q Inner[SbsQi]:

$$= P * h^2 * c / ( 12 * I_1 ) * ( ( 3 + 5 * \alpha^2 * K ) / ( 3 + 5 * K ) )$$

$$= 37.70 * 146.00^2 * 8.50 / ( 12 * 0.04 ) * ( ( 3 + 5 * 0.73^2 * 0.73 ) / ( 3 + 5 * 0.73 ) )$$

$$= 103.04 \text{ N./mm}^2$$

Bending Stress at Short-side 1 at Q Outer[SbsQo]:

$$= P * h^2 * c / ( 12 * I_1 ) * ( ( 3 + 5 * \alpha^2 * K ) / ( 3 + 5 * K ) )$$

FileName : HYDROTEST-FRONT-rev.02

Rectves Analysis : FRONT

Item: 1 4:03p Jul 28,2024

$$= 37.70 * 146.00^2 * -8.50 / ( 12 * 0.04 ) * (( 3 + 5 * 0.73^2 * 0.73 ) / ( 3 + 5 * 0.73 ))$$

$$= -103.04 \text{ N./mm}^2$$

**Bending Stresses at Short-side 2**

Bending Stress at Short-side 2 at N Inner[SbsNi]:

$$= P * c / ( 24 * I1 ) * [ -3 * H^2 + 2 * h^2 * (( 3 + 5 * Alpha^2 * K ) / ( 3 + 5 * K )) ]$$

$$= 37.70 * 8.50 / ( 24 * 0.04 ) * [ -3 * 106.00^2 + 2 * 146.00^2 * (( 3 + 5 * 0.73^2 * 0.73 ) / ( 3 + 5 * 0.73 )) ]$$

$$= -6.89 \text{ N./mm}^2$$

Bending Stress at Short-side 2 at N Outer[SbsNo]:

$$= P * c / ( 24 * I1 ) * [ -3 * H^2 + 2 * h^2 * (( 3 + 5 * Alpha^2 * K ) / ( 3 + 5 * K )) ]$$

$$= 37.70 * -8.50 / ( 24 * 0.04 ) * [ -3 * 106.00^2 + 2 * 146.00^2 * (( 3 + 5 * 0.73^2 * 0.73 ) / ( 3 + 5 * 0.73 )) ]$$

$$= 6.89 \text{ N./mm}^2$$

Bending Stress at Short-side 2 at Q Inner[SbsQi]:

$$= P * h^2 * c / ( 12 * I1 ) * (( 3 + 5 * Alpha^2 * K ) / ( 3 + 5 * K ))$$

$$= 37.70 * 146.00^2 * 8.50 / ( 12 * 0.04 ) * (( 3 + 5 * 0.73^2 * 0.73 ) / ( 3 + 5 * 0.73 ))$$

$$= 103.04 \text{ N./mm}^2$$

Bending Stress at Short-side 2 at Q Outer[SbsQo]:

$$= P * h^2 * c / ( 12 * I1 ) * (( 3 + 5 * Alpha^2 * K ) / ( 3 + 5 * K ))$$

$$= 37.70 * 146.00^2 * -8.50 / ( 12 * 0.04 ) * (( 3 + 5 * 0.73^2 * 0.73 ) / ( 3 + 5 * 0.73 ))$$

$$= -103.04 \text{ N./mm}^2$$

**Bending Stresses at Long-side 1**

Bending Stress at Long-side 1 at M Inner[SblMi]:

$$= P * h^2 * c / ( 12 * I2 ) * [( 3 + K * ( 6 - Alpha^2 ) ) / ( 3 + 5 * K )]$$

$$= 37.70 * 146.00^2 * 8.35 / ( 12 * 0.04 ) * [( 3 + 0.73 * ( 6 - 0.73^2 ) ) / ( 3 + 5 * 0.73 )]$$

$$= 143.67 \text{ N./mm}^2$$

If  $E_m(0.579) < E(0.850)$  and  $E_b(0.553) < E(0.850)$  then

$$SblMi = SblMi / Eb$$

$$= 143.67 / 0.55$$

$$= 259.94 \text{ N./mm}^2$$

Bending Stress at Long-side 1 at M Outer[SblMo]:

$$= P * h^2 * c / ( 12 * I2 ) * [( 3 + K * ( 6 - Alpha^2 ) ) / ( 3 + 5 * K )]$$

$$= 37.70 * 146.00^2 * -8.65 / ( 12 * 0.04 ) * [( 3 + 0.73 * ( 6 - 0.73^2 ) ) / ( 3 + 5 * 0.73 )]$$

$$= -148.81 \text{ N./mm}^2$$

If  $E_m(0.579) < E(0.850)$  and  $E_b(0.553) < E(0.850)$  then

$$SblMo = SblMo / Eb$$

$$= -148.81 / 0.55$$

$$= -269.24 \text{ N./mm}^2$$

Bending Stress at Long-side 1 at Q Inner[SblQi]:

$$= P * h^2 * c / ( 12 * I2 ) * [( 3 + 5 * Alpha^2 * K ) / ( 3 + 5 * K )]$$

$$= 37.70 * 146.00^2 * 8.35 / ( 12 * 0.04 ) * [( 3 + 5 * 0.73^2 * 0.73 ) / ( 3 + 5 * 0.73 )]$$

$$= 101.23 \text{ N./mm}^2$$

Bending Stress at Long-side 1 at Q Outer[SblQo]:

$$= P * h^2 * c / ( 12 * I2 ) * [( 3 + 5 * Alpha^2 * K ) / ( 3 + 5 * K )]$$

$$= 37.70 * 146.00^2 * -8.65 / ( 12 * 0.04 ) * [ ( 3 + 5 * 0.73^2 * 0.73 ) / ( 3 + 5 * 0.73 ) ]$$

$$= -104.85 \text{ N./mm}^2$$

**Bending Stresses at Long-side 2**

Bending Stress at Long-side 2 at M Inner[SblMi]:

$$= P * h^2 * c / ( 12 * I2 ) * [ ( 3 + K * ( 6 - Alpha^2) ) / ( 3 + 5 * K ) ]$$

$$= 37.70 * 146.00^2 * 8.50 / ( 12 * 0.04 ) * [ ( 3 + 0.73 * ( 6 - 0.73^2) ) / ( 3 + 5 * 0.73 ) ]$$

$$= 146.24 \text{ N./mm}^2$$

If  $E_m(0.632) < E(0.850)$  and  $E_b(0.632) < E(0.850)$  then

$$SblMi = SblMi / Eb$$

$$= 146.24 / 0.63$$

$$= 231.37 \text{ N./mm}^2$$

Bending Stress at Long-side 2 at M Outer[SblMo]:

$$= P * h^2 * c / ( 12 * I2 ) * [ ( 3 + K * ( 6 - Alpha^2) ) / ( 3 + 5 * K ) ]$$

$$= 37.70 * 146.00^2 * -8.50 / ( 12 * 0.04 ) * [ ( 3 + 0.73 * ( 6 - 0.73^2) ) / ( 3 + 5 * 0.73 ) ]$$

$$= -146.24 \text{ N./mm}^2$$

If  $E_m(0.632) < E(0.850)$  and  $E_b(0.632) < E(0.850)$  then

$$SblMo = SblMo / Eb$$

$$= -146.24 / 0.63$$

$$= -231.37 \text{ N./mm}^2$$

Bending Stress at Long-side 2 at Q Inner[SblQi]:

$$= P * h^2 * c / ( 12 * I2 ) * [ ( 3 + 5 * Alpha^2 * K ) / ( 3 + 5 * K ) ]$$

$$= 37.70 * 146.00^2 * 8.50 / ( 12 * 0.04 ) * [ ( 3 + 5 * 0.73^2 * 0.73 ) / ( 3 + 5 * 0.73 ) ]$$

$$= 103.04 \text{ N./mm}^2$$

Bending Stress at Long-side 2 at Q Outer[SblQo]:

$$= P * h^2 * c / ( 12 * I2 ) * [ ( 3 + 5 * Alpha^2 * K ) / ( 3 + 5 * K ) ]$$

$$= 37.70 * 146.00^2 * -8.50 / ( 12 * 0.04 ) * [ ( 3 + 5 * 0.73^2 * 0.73 ) / ( 3 + 5 * 0.73 ) ]$$

$$= -103.04 \text{ N./mm}^2$$

**BENDING STRESSES: Bending Stress Calculations per Section 13-9, Equations (16-19). (N./mm<sup>2</sup>) :**

STRESS LOCATIONS	Inner	Outer	Allowable
Short-side 1 at N	-6.89	6.89	270.30
at Q	103.04	-103.04	270.30
Short-side 2 at N	-6.89	6.89	270.30
at Q	103.04	-103.04	270.30
Long-side 1 at M	259.94	-269.24	318.00
at Q	101.23	-104.85	270.30
Long-side 2 at M	231.37	-231.37	318.00
at Q	103.04	-103.04	270.30

**Total Stress Calculations per Section 13-9**

**Total Stresses at Short-side 1**

Total Stress at short side 1 at N inner [STS\_Ni]:

$$= Sms + SbsNi$$

$$= 15.35 + -6.89$$

$$= 8.46 \text{ N./mm}^2$$

Total Stress at short side 1 at N outer [STS\_No]:

$$= Sms + SbsNo$$

$$= 15.35 + 6.89$$

$$= 22.25 \text{ N./mm}^2$$

FileName : HYDROTEST-FRONT-rev.02

Rectves Analysis : FRONT

Item: 1 4:03p Jul 28,2024

Total Stress at short side 1 at Q inner [STS\_Qi]:

$$\begin{aligned} &= S_{ms} + S_{bsQi} \\ &= 15.35 + 103.04 \\ &= 118.39 \text{ N./mm}^2 \end{aligned}$$

Total Stress at short side 1 at Q outer [STS\_Qo]:

$$\begin{aligned} &= S_{ms} + S_{bsQo} \\ &= 15.35 + -103.04 \\ &= -87.69 \text{ N./mm}^2 \end{aligned}$$

**Total Stresses at Short-side 2**

Total Stress at short side 2 at N inner [STS\_Ni]:

$$\begin{aligned} &= S_{ms} + S_{bsNi} \\ &= 15.35 + -6.89 \\ &= 8.46 \text{ N./mm}^2 \end{aligned}$$

Total Stress at short side 2 at N outer [STS\_No]:

$$\begin{aligned} &= S_{ms} + S_{bsNo} \\ &= 15.35 + 6.89 \\ &= 22.25 \text{ N./mm}^2 \end{aligned}$$

Total Stress at short side 2 at Q inner [STS\_Qi]:

$$\begin{aligned} &= S_{ms} + S_{bsQi} \\ &= 15.35 + 103.04 \\ &= 118.39 \text{ N./mm}^2 \end{aligned}$$

Total Stress at short side 2 at Q outer [STS\_Qo]:

$$\begin{aligned} &= S_{ms} + S_{bsQo} \\ &= 15.35 + -103.04 \\ &= -87.69 \text{ N./mm}^2 \end{aligned}$$

**Total Stresses at Long-side 1**

Total Stress at long side 1 at M inner [STL\_Mi]:

$$\begin{aligned} &= S_{m1} + S_{b1Mi} \\ &= 20.29 + 259.94 \\ &= 280.23 \text{ N./mm}^2 \end{aligned}$$

Total Stress at long side 1 at M outer [STL\_Mo]:

$$\begin{aligned} &= S_{m1} + S_{b1Mo} \\ &= 20.29 + -269.24 \\ &= -248.95 \text{ N./mm}^2 \end{aligned}$$

Total Stress at long side 1 at Q inner [STL\_Qi]:

$$\begin{aligned} &= S_{m1} + S_{b1Qi} \\ &= 11.75 + 101.23 \\ &= 112.99 \text{ N./mm}^2 \end{aligned}$$

Total Stress at long side 1 at Q outer [STL\_Qo]:

$$\begin{aligned} &= S_{m1B} + S_{b1Qo} \\ &= 11.75 + -104.85 \\ &= -93.10 \text{ N./mm}^2 \end{aligned}$$

**Total Stresses at Long-side 2**

Total Stress at long side 2 at M inner [STL\_Mi]:

$$\begin{aligned} &= S_{m1} + S_{b1Mi} \\ &= 18.60 + 231.37 \\ &= 249.97 \text{ N./mm}^2 \end{aligned}$$

Total Stress at long side 2 at M outer [STL\_Mo]:

$$\begin{aligned} &= S_{m1} + S_{b1Mo} \\ &= 18.60 + -231.37 \\ &= -212.77 \text{ N./mm}^2 \end{aligned}$$

Total Stress at long side 2 at Q inner [STL\_Qi]:

$$\begin{aligned} &= S_{m1} + S_{b1Qi} \\ &= 11.75 + 103.04 \end{aligned}$$

= 114.80 N./mm<sup>2</sup>

Total Stress at long side 2 at Q outer [STL\_Qo]:

= SmlB + SblQo  
 = 11.75 + -103.04  
 = -91.29 N./mm<sup>2</sup>

**TOTAL STRESSES: Total Stress Calculations per Section 13-9, Equations (20-24). (N./mm<sup>2</sup>) :**

STRESS LOCATIONS	Inner	Outer	Allowable
Short-side 1 at N	8.46	22.25	270.30
at Q	118.39	-87.69	270.30
Short-side 2 at N	8.46	22.25	270.30
at Q	118.39	-87.69	270.30
Long-side 1 at M	280.23	-248.95	318.00
at Q	112.99	-93.10	270.30
Long-side 2 at M	249.97	-212.77	318.00
at Q	114.80	-91.29	270.30

**END PLATE STRESSES (N./mm<sup>2</sup>) :**

	Actual	Allowable
End Plate	73.29	212.00

**SUMMARY OF RESULTS:**

**MEMBRANE STRESS SUMMARY,**

High Stress (Highest % of Allowable)	94.12	N./mm <sup>2</sup>
High Stress Percentage	44.39	%
M.A.W.P. for Membrane Stresses	84.92	bars

**BENDING STRESS SUMMARY,**

High Stress (Highest % of Allowable)	-269.24	N./mm <sup>2</sup>
High Stress Percentage	84.67	%
M.A.W.P. for Bending Stresses	44.53	bars

**TOTAL STRESS SUMMARY,**

High Stress (Highest % of Allowable)	280.23	N./mm <sup>2</sup>
High Stress Percentage	88.12	%
M.A.W.P. for Total Stresses	42.78	bars

**Rectangular Vessel Results For Item 1 : A8**

**SUMMARY OF RESULTS:**

**MEMBRANE STRESS SUMMARY,**

High Stress (Highest % of Allowable)	94.12	N./mm <sup>2</sup>
High Stress Percentage	44.39	%
M.A.W.P. for Membrane Stresses	84.92	bars

**BENDING STRESS SUMMARY,**

High Stress (Highest % of Allowable)	-269.24	N./mm <sup>2</sup>
High Stress Percentage	84.67	%
M.A.W.P. for Bending Stresses	44.53	bars

**TOTAL STRESS SUMMARY,**

High Stress (Highest % of Allowable)	280.23	N./mm <sup>2</sup>
High Stress Percentage	88.12	%
M.A.W.P. for Total Stresses	42.78	bars

Input Echo, COMPONENT 1, Description: REAR

Figure Number Analyzed		A7	
Design Internal Pressure	P	37.7000	bars
Design Temperature	Temp	120.0000	C
VESSEL MATERIAL DATA:			
Material Specification		SA-516 70	
Shell Allowable Stress at Design Temp	S	212.0000	N./mm^2
Shell Allowable Stress at Ambient	SA	212.0000	N./mm^2
Shell Yield Stress at Design Temperature	Sy	235.9761	N./mm^2
SHORT-SIDE VESSEL DATA:			
Short-side Length Dimension	H	100.0000	mm.
Minimum Thickness of Short-side Plates	t1	20.0000	mm.
Mid-side Joint Efficiency on Short-side	E	0.8500	
Corner Joint Efficiency on Short-side	EC	0.8500	
LONG-SIDE VESSEL DATA:			
Long-side Length Dimension	h	138.0000	mm.
Minimum Thickness of Long-side Plates	t2	20.0000	mm.
Mid-side Joint Efficiency on Long-side	E	0.8500	
ADDITIONAL VESSEL DATA:			
Minimum Thickness of End Plate	t5	20.0000	mm.
C-Factor for End Plate	Cf_Epl	0.2000	
Corrosion Allowance of Shell	CA	3.0000	mm.
Long-side Plate # 1,			
Pitch Distance	p	69.8500	mm.
# 1: Hole Diameter	d0	36.5000	mm.
Hole Depth	T0	1.7000	mm.
# 2: Hole Diameter	d1	28.6000	mm.
Hole Depth	T1	18.3000	mm.
Long-side Plate # 2,			
Pitch Distance	p	69.8500	mm.
Uniform Hole Diameter	d0	25.7000	mm.
Depth of Holes	T0	20.0000	mm.
STAY PLATE MATERIAL DATA:			
Stay Material Specification		SA-516 70	
Stay Allowable Stress at Design Temp	Sr	212.0000	N./mm^2
Stay Allowable Stress at Ambient	SA	212.0000	N./mm^2
Stay Yield Stress at Design Temp	Sy	235.9761	N./mm^2
STAY PLATE DATA:			
Minimum Thickness of Stay	t3	12.0000	mm.
The Stay(s) Are Not Welded to the End Plate			
Corrosion Allowance of Stay	CAS	3.0000	mm.

REV.03

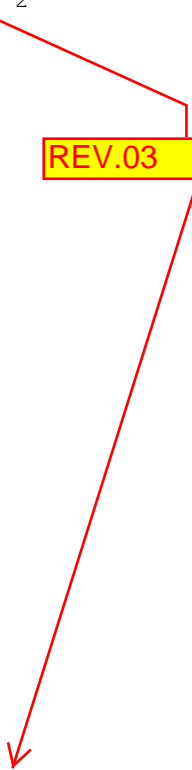

Rectangular Vessel Results, Item number 1, Desc: REAR ASME Code, Section VIII, Division 1, 2017 App. 13

Ligament Efficiency Calculations (Section 13-6, Equations (1)-(6)):

Short-side 1 Calculations

Membrane Ligament Efficiency [Em]: = 0.850

Bending Ligament Efficiency [Eb]: = 0.850

Dist from Neutral axis of c/s to inside surface of the vessel [Ci]: = t1 - CA / 2 = 20.000 - 3.000 / 2 = 8.500 mm.

FileName : HYDROTEST-REAR-rev.02

Rectves Analysis : REAR

Item: 1 4:07p Jul 28,2024

Dist from Neutral axis of c/s to extreme outside surface of the section [Co]:

$$\begin{aligned}
 &= -(t_1 - CA) / 2 \\
 &= -(20.000 - 3.000) / 2 \\
 &= -8.500 \text{ mm.}
 \end{aligned}$$

**Short-side 2 Calculations**

Membrane Ligament Efficiency [Em]:

$$= 0.850$$

Bending Ligament Efficiency [Eb]:

$$= 0.850$$

Dist from Neutral axis of c/s to inside surface of the vessel [Ci]:

$$\begin{aligned}
 &= t_1 - CA / 2 \\
 &= 20.000 - 3.000 / 2 \\
 &= 8.500 \text{ mm.}
 \end{aligned}$$

Dist from Neutral axis of c/s to extreme outside surface of the section [Co]:

$$\begin{aligned}
 &= -(t_1 - CA) / 2 \\
 &= -(20.000 - 3.000) / 2 \\
 &= -8.500 \text{ mm.}
 \end{aligned}$$

**Long-side 1 Calculations**

Effective Diameter [De]:

$$\begin{aligned}
 &= (d_0 * T_0 + d_1 * T_1 + d_2 * T_2) / (t_1 - CA) \\
 &= (36.50 * 1.70 + 28.60 * 15.30 + 0.00 * 0.00) / \\
 &\quad (20.00 - 3.00) \\
 &= 29.390 \text{ mm.}
 \end{aligned}$$

Membrane Ligament Efficiency [Em]:

$$\begin{aligned}
 &= \text{Pitch} - De / \text{Pitch} \\
 &= 69.850 - 29.390 / 69.850 \\
 &= 0.579
 \end{aligned}$$

Dist from Neutral axis of c/s to extreme fibers [Ci &amp; Co]:

**Calculation of Xbar:**

$$\begin{aligned}
 &= ((b_0 * T_0 * (T_0/2 + T_1 + T_2)) + (b_1 * T_1 * \\
 &\quad (T_1/2 + T_2)) + (b_2 * T_2 * (T_2/2))) / \\
 &\quad (b_0 * T_0 + b_1 * T_1 + b_2 * T_2) \\
 &= ((1.31 * 1.70 * (1.70 / 2 + 15.30 + 0.00)) + (1.62 * 15.30 * \\
 &\quad (15.30 / 2 + 0.00)) + (2.75 * 0.00 * (0.00 / 2))) / \\
 &\quad (1.31 * 1.70 + 1.62 * 15.30 + 2.75 * 0.00) \\
 &= 8.351 \text{ mm.}
 \end{aligned}$$

Dist from Neutral axis of c/s to inside surface of the vessel [Ci]:

 $C_i = Xbar$ 

$$= 8.351 \text{ mm.}$$

Dist from Neutral axis of c/s to extreme outside surface of the section [Co]:

$$\begin{aligned}
 &= -(t - CA - Xbar) \\
 &= -(20.000 - 3.000 - 8.351) \\
 &= -8.649 \text{ mm.}
 \end{aligned}$$

Moment of Inertia (Section 13-6, Equation (5)) [I]:

$$= 0.063 \text{ cm}^4$$

Effective Diameter [De]:

$$\begin{aligned}
 &= \text{Pitch} - ((6 * I) / ((t - CA)^2 * (-Co))) \\
 &= 69.85 - ((6 * 0.06) / ((20.00 - 3.00)^2 * (8.65))) \\
 &= 31.244 \text{ mm.}
 \end{aligned}$$

Bending Ligament Efficiency [Eb]:

$$\begin{aligned}
 &= \text{Pitch} - De / \text{Pitch} \\
 &= 69.850 - 31.244 / 69.850 \\
 &= 0.553
 \end{aligned}$$

**Long-side 2 Calculations**

Effective Diameter [De]: 25.700 mm.

Membrane Ligament Efficiency [Em]:

$$= \text{Pitch} - \text{De} / \text{Pitch}$$

$$= 69.850 - 25.700 / 69.850$$

$$= 0.632$$

Bending Ligament Efficiency [Eb]:

As diameter holes are uniform  $E_b = E_m$

$$= 0.632$$

Dist from Neutral axis of c/s to inside surface of the vessel [Ci]:

$$= t_1 - \text{CA} / 2$$

$$= 20.000 - 3.000 / 2$$

$$= 8.500 \text{ mm.}$$

Dist from Neutral axis of c/s to extreme outside surface of the section [Co]:

$$= -(t_1 - \text{CA}) / 2$$

$$= -(20.000 - 3.000) / 2$$

$$= -8.500 \text{ mm.}$$

**Ligament Efficiency Calculations (Section 13-6, Equations (1)-(6)):**

	Em	Eb	Ci	Co
Short-side 1	0.850	0.850	8.500	-8.500
2	0.850	0.850	8.500	-8.500
Long-side 1	0.579	0.553	8.351	-8.649
2	0.632	0.632	8.500	-8.500

**Moment of Inertia of a Strip of the Vessel Wall:**

$$\text{Thickness } t_1, I_1 = 0.0409 \text{ cm}^{*4}$$

$$\text{Thickness } t_2, I_2 = 0.0409 \text{ cm}^{*4}$$

**Rectangular Vessel Parameters:**

$$\text{Alpha} = H / h = 0.7361$$

$$K = (I_2 / I_1) * \text{Alpha} = 0.7361$$

**Membrane Stress Calculations per Section 13-9**

**Membrane Stresses at Short-side 1**

Membrane Stress at Short-side 1 [Sms]:

$$= p * h / (4 * t_1) * \{ 4 - [(2 + K * (5 - \text{alpha}^2)) / (1 + 2 * K)] \}$$

$$= 37.70 * 144.00 / (4 * 17.00) * \{ 4 - [(2 + 0.74 * (5 - 0.74^2)) / (1 + 2 * 0.74)] \}$$

$$= 14.88 \text{ N./mm}^2$$

**Membrane Stresses at Short-side 2**

Membrane Stress at Short-side 2 [Sms]:

$$= p * h / (4 * t_1) * \{ 4 - [(2 + K * (5 - \text{alpha}^2)) / (1 + 2 * K)] \}$$

$$= 37.70 * 144.00 / (4 * 17.00) * \{ 4 - [(2 + 0.74 * (5 - 0.74^2)) / (1 + 2 * 0.74)] \}$$

$$= 14.88 \text{ N./mm}^2$$

**Membrane Stresses at Long-side 1**

Membrane Stress at Long-side 1 at A [Sml]:

$$= P * H / 2 * t_2$$

$$= 37.70 * 106.00 / 2 * 17.00$$

$$= 11.75 \text{ N./mm}^2$$

If  $E_m(0.579) < E(0.850)$  and  $E_b(0.553) < E(0.850)$  then

$$S_{m1} = S_{m1} / E_m$$

$$= 11.75 / 0.58$$

$$= 20.29 \text{ N./mm}^2$$

**Membrane Stresses at Long-side 2**

Membrane Stress at Long-side 2 at A [Sml]:

$$= P * H / 2 * t^2$$

$$= 37.70 * 106.00 / 2 * 17.00$$

$$= 11.75 \text{ N./mm}^2$$

If  $E_m(0.632) < E(0.850)$  and  $E_b(0.632) < E(0.850)$  then

$$S_{ml} = S_{ml} / E_m$$

$$= 11.75 / 0.63$$

$$= 18.60 \text{ N./mm}^2$$

**Membrane Stresses at Stay Plate**

Membrane Stress at Stay Plate [Smsp]:

$$= P * h / ( 2 * t^3 ) * [ ( 2 + K * ( 5 - \alpha^2 ) ) / ( 1 + 2 * K ) ]$$

$$= 37.70 * 144.00 / ( 2 * 6.00 ) * [ ( 2 + 0.74 * ( 5 - 0.74^2 ) ) / ( 1 + 2 * 0.74 ) ]$$

$$= 96.66 \text{ N./mm}^2$$

**MEMBRANE STRESSES: Membrane Stress Calculations per Section 13-9, Equations (1-3). (N./mm<sup>2</sup>) :**

STRESS LOCATIONS	Actual	Allowable
Short-side 1	14.88	180.20
Short-side 2	14.88	180.20
Short-side Corner	14.88	180.20
Long-side 1 at A	20.29	212.00
Long-side 2 at A	18.60	212.00
Long-side Corner	11.75	180.20
Stay Plate (t3)	96.66	212.00

**Bending Stress Calculations per Section 13-9**

**Bending Stresses at Short-side 1**

Bending Stress at Short-side 1 at N Inner[SbsNi]:

$$= P * c / ( 24 * I1 ) * [ -3 * H^2 + 2 * h^2 * ( ( 1 + 2 * \alpha^2 * K ) / ( 1 + 2 * K ) ) ]$$

$$= 37.70 * 8.50 / ( 24 * 0.04 ) * [ -3 * 106.00^2 + 2 * 144.00^2 * ( ( 1 + 2 * 0.74^2 * 0.74 ) / ( 1 + 2 * 0.74 ) ) ]$$

$$= -11.58 \text{ N./mm}^2$$

Bending Stress at Short-side 1 at N Outer[SbsNo]:

$$= P * c / ( 24 * I1 ) * [ -3 * H^2 + 2 * h^2 * ( ( 1 + 2 * \alpha^2 * K ) / ( 1 + 2 * K ) ) ]$$

$$= 37.70 * -8.50 / ( 24 * 0.04 ) * [ -3 * 106.00^2 + 2 * 144.00^2 * ( ( 1 + 2 * 0.74^2 * 0.74 ) / ( 1 + 2 * 0.74 ) ) ]$$

$$= 11.58 \text{ N./mm}^2$$

Bending Stress at Short-side 1 at Q Inner[SbsQi]:

$$= P * h^2 * c / ( 12 * I1 ) * ( ( 1 + 2 * \alpha^2 * K ) / ( 1 + 2 * K ) )$$

$$= 37.70 * 144.00^2 * 8.50 / ( 12 * 0.04 ) * ( ( 1 + 2 * 0.74^2 * 0.74 ) / ( 1 + 2 * 0.74 ) )$$

$$= 98.36 \text{ N./mm}^2$$

Bending Stress at Short-side 1 at Q Outer[SbsQo]:

$$= P * h^2 * c / ( 12 * I1 ) * ( ( 1 + 2 * \alpha^2 * K ) / ( 1 + 2 * K ) )$$

$$= 37.70 * 144.00^2 * -8.50 / ( 12 * 0.04 ) * ( ( 1 + 2 * 0.74^2 * 0.74 ) / ( 1 + 2 * 0.74 ) )$$

$$= -98.36 \text{ N./mm}^2$$

**Bending Stresses at Short-side 2**

Bending Stress at Short-side 2 at N Inner[SbsNi]:

$$= P * c / ( 24 * I1 ) * [ -3 * H^2 + 2 * h^2 * ( ( 1 + 2 * \alpha^2 * K ) / ( 1 + 2 * K ) ) ]$$

$$= 37.70 * 8.50 / ( 24 * 0.04 ) * [ -3 * 106.00^2 + 2 * 144.00^2 * (( 1 + 2 * 0.74^2 * 0.74 ) / ( 1 + 2 * 0.74 )) ]$$

$$= -11.58 \text{ N./mm}^2$$

**Bending Stress at Short-side 2 at N Outer[SbsNo]:**

$$= P * c / ( 24 * I1 ) * [ -3 * H^2 + 2 * h^2 * (( 1 + 2 * Alpha^2 * K ) / ( 1 + 2 * K )) ]$$

$$= 37.70 * -8.50 / ( 24 * 0.04 ) * [ -3 * 106.00^2 + 2 * 144.00^2 * (( 1 + 2 * 0.74^2 * 0.74 ) / ( 1 + 2 * 0.74 )) ]$$

$$= 11.58 \text{ N./mm}^2$$

**Bending Stress at Short-side 2 at Q Inner[SbsQi]:**

$$= P * h^2 * c / ( 12 * I1 ) * (( 1 + 2 * Alpha^2 * K ) / ( 1 + 2 * K ))$$

$$= 37.70 * 144.00^2 * 8.50 / ( 12 * 0.04 ) * (( 1 + 2 * 0.74^2 * 0.74 ) / ( 1 + 2 * 0.74 ))$$

$$= 98.36 \text{ N./mm}^2$$

**Bending Stress at Short-side 2 at Q Outer[SbsQo]:**

$$= P * h^2 * c / ( 12 * I1 ) * (( 1 + 2 * Alpha^2 * K ) / ( 1 + 2 * K ))$$

$$= 37.70 * 144.00^2 * -8.50 / ( 12 * 0.04 ) * (( 1 + 2 * 0.74^2 * 0.74 ) / ( 1 + 2 * 0.74 ))$$

$$= -98.36 \text{ N./mm}^2$$

**Bending Stresses at Long-side 1**

**Bending Stress at Long-side 1 at M Inner[SbIMi]:**

$$= P * h^2 * c / ( 12 * I2 ) * [( 1 + K * ( 3 - Alpha^2 ) ) / ( 1 + 2 * K )]$$

$$= 37.70 * 144.00^2 * 8.35 / ( 12 * 0.04 ) * [( 1 + 0.74 * ( 3 - 0.74^2 ) ) / ( 1 + 2 * 0.74 )]$$

$$= 151.01 \text{ N./mm}^2$$

*If Em( 0.579 ) < E( 0.850 ) and Eb( 0.553 ) < E( 0.850 ) then*

$$SbIMi = SbIMi / Eb$$

$$= 151.01 / 0.55$$

$$= 273.22 \text{ N./mm}^2$$

**Bending Stress at Long-side 1 at M Outer[SbIMo]:**

$$= P * h^2 * c / ( 12 * I2 ) * [( 1 + K * ( 3 - Alpha^2 ) ) / ( 1 + 2 * K )]$$

$$= 37.70 * 144.00^2 * -8.65 / ( 12 * 0.04 ) * [( 1 + 0.74 * ( 3 - 0.74^2 ) ) / ( 1 + 2 * 0.74 )]$$

$$= -156.41 \text{ N./mm}^2$$

*If Em( 0.579 ) < E( 0.850 ) and Eb( 0.553 ) < E( 0.850 ) then*

$$SbIMo = SbIMo / Eb$$

$$= -156.41 / 0.55$$

$$= -282.99 \text{ N./mm}^2$$

**Bending Stress at Long-side 1 at Q Inner[SbIQi]:**

$$= P * h^2 * c / ( 12 * I2 ) * [( 1 + 2 * Alpha^2 * K ) / ( 1 + 2 * K )]$$

$$= 37.70 * 144.00^2 * 8.35 / ( 12 * 0.04 ) * [( 1 + 2 * 0.74^2 * 0.74 ) / ( 1 + 2 * 0.74 )]$$

$$= 96.63 \text{ N./mm}^2$$

**Bending Stress at Long-side 1 at Q Outer[SbIQo]:**

$$= P * h^2 * c / ( 12 * I2 ) * [( 1 + 2 * Alpha^2 * K ) / ( 1 + 2 * K )]$$

$$= 37.70 * 144.00^2 * -8.65 / ( 12 * 0.04 ) * [( 1 + 2 * 0.74^2 * 0.74 ) / ( 1 + 2 * 0.74 )]$$

$$= -100.08 \text{ N./mm}^2$$

**Bending Stresses at Long-side 2**

**Bending Stress at Long-side 2 at M Inner[SbIMi]:**

$$= P * h^2 * c / ( 12 * I2 ) * [( 1 + K * ( 3 - Alpha^2 ) ) / ( 1 + 2 * K )]$$

$$= 37.70 * 144.00^2 * 8.50 / ( 12 * 0.04 ) * [( 1 + 0.74 * ( 3 - 0.74^2) ) / ( 1 + 2 * 0.74 )]$$

$$= 153.71 \text{ N./mm}^2$$

If  $E_m(0.632) < E(0.850)$  and  $E_b(0.632) < E(0.850)$  then

$$S_{blMi} = S_{blMi} / E_b$$

$$= 153.71 / 0.63$$

$$= 243.18 \text{ N./mm}^2$$

Bending Stress at Long-side 2 at M Outer[SblMo]:

$$= P * h^2 * c / ( 12 * I_2 ) * [( 1 + K * ( 3 - \text{Alpha}^2) ) / ( 1 + 2 * K )]$$

$$= 37.70 * 144.00^2 * -8.50 / ( 12 * 0.04 ) * [( 1 + 0.74 * ( 3 - 0.74^2) ) / ( 1 + 2 * 0.74 )]$$

$$= -153.71 \text{ N./mm}^2$$

If  $E_m(0.632) < E(0.850)$  and  $E_b(0.632) < E(0.850)$  then

$$S_{blMo} = S_{blMo} / E_b$$

$$= -153.71 / 0.63$$

$$= -243.18 \text{ N./mm}^2$$

Bending Stress at Long-side 2 at Q Inner[SblQi]:

$$= P * h^2 * c / ( 12 * I_2 ) * [( 1 + 2 * \text{Alpha}^2 * K ) / ( 1 + 2 * K )]$$

$$= 37.70 * 144.00^2 * 8.50 / ( 12 * 0.04 ) * [( 1 + 2 * 0.74^2 * 0.74 ) / ( 1 + 2 * 0.74 )]$$

$$= 98.36 \text{ N./mm}^2$$

Bending Stress at Long-side 2 at Q Outer[SblQo]:

$$= P * h^2 * c / ( 12 * I_2 ) * [( 1 + 2 * \text{Alpha}^2 * K ) / ( 1 + 2 * K )]$$

$$= 37.70 * 144.00^2 * -8.50 / ( 12 * 0.04 ) * [( 1 + 2 * 0.74^2 * 0.74 ) / ( 1 + 2 * 0.74 )]$$

$$= -98.36 \text{ N./mm}^2$$

**BENDING STRESSES: Bending Stress Calculations per Section 13-9, Equations (4-7). (N./mm<sup>2</sup>) :**

STRESS LOCATIONS	Inner	Outer	Allowable
Short-side 1 at N	-11.58	11.58	270.30
at Q	98.36	-98.36	270.30
Short-side 2 at N	-11.58	11.58	270.30
at Q	98.36	-98.36	270.30
Long-side 1 at M	273.22	-282.99	318.00
at Q	96.63	-100.08	270.30
Long-side 2 at M	243.18	-243.18	318.00
at Q	98.36	-98.36	270.30

**Total Stress Calculations per Section 13-9**

**Total Stresses at Short-side 1**

Total Stress at short side 1 at N inner [STS\_Ni]:

$$= S_{ms} + S_{bsNi}$$

$$= 14.88 + -11.58$$

$$= 3.30 \text{ N./mm}^2$$

Total Stress at short side 1 at N outer [STS\_No]:

$$= S_{ms} + S_{bsNo}$$

$$= 14.88 + 11.58$$

$$= 26.46 \text{ N./mm}^2$$

Total Stress at short side 1 at Q inner [STS\_Qi]:

$$= S_{ms} + S_{bsQi}$$

$$= 14.88 + 98.36$$

$$= 113.24 \text{ N./mm}^2$$

Total Stress at short side 1 at Q outer [STS\_Qo]:

$$= S_{ms} + S_{bsQo}$$

$$= 14.88 + -98.36$$

$$= -83.48 \text{ N./mm}^2$$

**Total Stresses at Short-side 2**

Total Stress at short side 2 at N inner [STS\_Ni]:

$$\begin{aligned} &= S_{ms} + S_{bsNi} \\ &= 14.88 + -11.58 \\ &= 3.30 \text{ N./mm}^2 \end{aligned}$$

Total Stress at short side 2 at N outer [STS\_No]:

$$\begin{aligned} &= S_{ms} + S_{bsNo} \\ &= 14.88 + 11.58 \\ &= 26.46 \text{ N./mm}^2 \end{aligned}$$

Total Stress at short side 2 at Q inner [STS\_Qi]:

$$\begin{aligned} &= S_{ms} + S_{bsQi} \\ &= 14.88 + 98.36 \\ &= 113.24 \text{ N./mm}^2 \end{aligned}$$

Total Stress at short side 2 at Q outer [STS\_Qo]:

$$\begin{aligned} &= S_{ms} + S_{bsQo} \\ &= 14.88 + -98.36 \\ &= -83.48 \text{ N./mm}^2 \end{aligned}$$

**Total Stresses at Long-side 1**

Total Stress at long side 1 at M inner [STL\_Mi]:

$$\begin{aligned} &= S_{m1} + S_{b1Mi} \\ &= 20.29 + 273.22 \\ &= 293.51 \text{ N./mm}^2 \end{aligned}$$

Total Stress at long side 1 at M outer [STL\_Mo]:

$$\begin{aligned} &= S_{m1} + S_{b1Mo} \\ &= 20.29 + -282.99 \\ &= -262.70 \text{ N./mm}^2 \end{aligned}$$

Total Stress at long side 1 at Q inner [STL\_Qi]:

$$\begin{aligned} &= S_{m1} + S_{b1Qi} \\ &= 11.75 + 96.63 \\ &= 108.38 \text{ N./mm}^2 \end{aligned}$$

Total Stress at long side 1 at Q outer [STL\_Qo]:

$$\begin{aligned} &= S_{m1} + S_{b1Qo} \\ &= 11.75 + -100.08 \\ &= -88.33 \text{ N./mm}^2 \end{aligned}$$

**Total Stresses at Long-side 2**

Total Stress at long side 2 at M inner [STL\_Mi]:

$$\begin{aligned} &= S_{m1} + S_{b1Mi} \\ &= 18.60 + 243.18 \\ &= 261.78 \text{ N./mm}^2 \end{aligned}$$

Total Stress at long side 2 at M outer [STL\_Mo]:

$$\begin{aligned} &= S_{m1} + S_{b1Mo} \\ &= 18.60 + -243.18 \\ &= -224.59 \text{ N./mm}^2 \end{aligned}$$

Total Stress at long side 2 at Q inner [STL\_Qi]:

$$\begin{aligned} &= S_{m1} + S_{b1Qi} \\ &= 11.75 + 98.36 \\ &= 110.11 \text{ N./mm}^2 \end{aligned}$$

Total Stress at long side 2 at Q outer [STL\_Qo]:

$$\begin{aligned} &= S_{m1} + S_{b1Qo} \\ &= 11.75 + -98.36 \\ &= -86.60 \text{ N./mm}^2 \end{aligned}$$

**TOTAL STRESSES: Total Stress Calculations per Section 13-9,**

**Equations (8-12). (N./mm<sup>2</sup>) :**

STRESS LOCATIONS	Inner	Outer	Allowable
Short-side 1 at N	3.30	26.46	270.30
at Q	113.24	-83.48	270.30
Short-side 2 at N	3.30	26.46	270.30
at Q	113.24	-83.48	270.30
Long-side 1 at M	293.51	-262.70	318.00
at Q	108.38	-88.33	270.30
Long-side 2 at M	261.78	-224.59	318.00
at Q	110.11	-86.60	270.30

**END PLATE STRESSES (N./mm<sup>2</sup>) :**

	Actual	Allowable
End Plate	73.29	212.00

**SUMMARY OF RESULTS:**

**MEMBRANE STRESS SUMMARY,**

High Stress (Highest % of Allowable)	96.66	N./mm <sup>2</sup>
High Stress Percentage	45.59	%
M.A.W.P. for Membrane Stresses	82.69	bars

**BENDING STRESS SUMMARY,**

High Stress (Highest % of Allowable)	-282.99	N./mm <sup>2</sup>
High Stress Percentage	88.99	%
M.A.W.P. for Bending Stresses	42.36	bars

**TOTAL STRESS SUMMARY,**

High Stress (Highest % of Allowable)	293.51	N./mm <sup>2</sup>
High Stress Percentage	92.30	%
M.A.W.P. for Total Stresses	40.85	bars

**Rectangular Vessel Results For Item 1 : A7**

**SUMMARY OF RESULTS:**

**MEMBRANE STRESS SUMMARY,**

High Stress (Highest % of Allowable)	96.66	N./mm <sup>2</sup>
High Stress Percentage	45.59	%
M.A.W.P. for Membrane Stresses	82.69	bars

**BENDING STRESS SUMMARY,**

High Stress (Highest % of Allowable)	-282.99	N./mm <sup>2</sup>
High Stress Percentage	88.99	%
M.A.W.P. for Bending Stresses	42.36	bars

**TOTAL STRESS SUMMARY,**

High Stress (Highest % of Allowable)	293.51	N./mm <sup>2</sup>
High Stress Percentage	92.30	%
M.A.W.P. for Total Stresses	40.85	bars

### 3. Stationary & rear header Box code calc in FV

**Input Echo, COMPONENT 1, Description: FRONT**

Figure Number Analyzed		A1	
Design Internal Pressure	P	0.0100	bars
Design External Pressure	Pext	1.0000	bars
Design Temperature	Temp	120.0000	C
VESSEL MATERIAL DATA:			
Material Specification		SA-516 70	
Shell Allowable Stress at Design Temp	S	137.9000	N./mm^2
Shell Allowable Stress at Ambient	SA	137.9000	N./mm^2
Shell Yield Stress at Design Temperature	Sy	235.9761	N./mm^2
Length of Vessel	Lv	2510.0000	mm.
SHORT-SIDE VESSEL DATA:			
Short-side Length Dimension	H	100.0000	mm.
Minimum Thickness of Short-side Plates	t1	20.0000	mm.
Mid-side Joint Efficiency on Short-side	E	0.8500	
Corner Joint Efficiency on Short-side	EC	0.8500	
LONG-SIDE VESSEL DATA:			
Long-side Length Dimension	h	349.0000	mm.
Minimum Thickness of Long-side Plates	t2	20.0000	mm.
Mid-side Joint Efficiency on Long-side	E	0.8500	
ADDITIONAL VESSEL DATA:			
Minimum Thickness of End Plate	t5	20.0000	mm.
C-Factor for End Plate	Cf_Epl	0.2000	
Corrosion Allowance of Shell	CA	3.0000	mm.
Long-side Plate # 1,			
Pitch Distance	p	69.8500	mm.
# 1: Hole Diameter	d0	36.5000	mm.
Hole Depth	T0	1.7000	mm.
# 2: Hole Diameter	d1	28.6000	mm.
Hole Depth	T1	18.3000	mm.
Long-side Plate # 2,			
Pitch Distance	p	69.8500	mm.
Uniform Hole Diameter	d0	25.7000	mm.
Depth of Holes	T0	20.0000	mm.

**Internal Pressure Results, Rect. Vessel # 1, Desc: FRONT**  
**ASME Code, Section VIII, Division 1, 2017 App. 13**

**Ligament Efficiency Calculations (Section 13-6, Equations (1)-(6)):**

**Short-side 1 Calculations**

Membrane Ligament Efficiency [Em]:  
 = 0.850

Bending Ligament Efficiency [Eb]:  
 = 0.850

Dist from Neutral axis of c/s to inside surface of the vesssel [Ci]:  
 = t1 - CA / 2  
 = 20.000 - 3.000 / 2  
 = 8.500 mm.

Dist from Neutral axis of c/s to extreme outside surface of the section [Co]:  
 = -( t1 - CA ) / 2  
 = -( 20.000 - 3.000 ) / 2  
 = -8.500 mm.

**Short-side 2 Calculations**

Membrane Ligament Efficiency [Em]:

FileName : F.V.FRONT-rev.01

Rectves Analysis : FRONT

Item: 1 1:25p Jul 20,2024

$$= 0.850$$

Bending Ligament Efficiency [Eb]:

$$= 0.850$$

Dist from Neutral axis of c/s to inside surface of the vessel [Ci]:

$$\begin{aligned} &= t1 - CA / 2 \\ &= 20.000 - 3.000 / 2 \\ &= 8.500 \text{ mm.} \end{aligned}$$

Dist from Neutral axis of c/s to extreme outside surface of the section [Co]:

$$\begin{aligned} &= -( t1 - CA ) / 2 \\ &= -( 20.000 - 3.000 ) / 2 \\ &= -8.500 \text{ mm.} \end{aligned}$$

**Long-side 1 Calculations**

Effective Diameter [De]:

$$\begin{aligned} &= ( d0 * T0 + d1 * T1 + d2 * T2 ) / ( t1 - CA ) \\ &= ( 36.50 * 1.70 + 28.60 * 15.30 + 0.00 * 0.00 ) / \\ &\quad ( 20.00 - 3.00 ) \\ &= 29.390 \text{ mm.} \end{aligned}$$

Membrane Ligament Efficiency [Em]:

$$\begin{aligned} &= Pitch - De / Pitch \\ &= 69.850 - 29.390 / 69.850 \\ &= 0.579 \end{aligned}$$

Dist from Neutral axis of c/s to extreme fibers [Ci &amp; Co]:

*Calculation of Xbar:*

$$\begin{aligned} &= ( ( b0 * T0 * ( T0/2 + T1 + T2 ) ) + ( b1 * T1 * \\ &\quad ( T1/2 + T2 ) ) + ( b2 * T2 * ( T2/2 ) ) ) / \\ &\quad ( b0 * T0 + b1 * T1 + b2 * T2 ) \\ &= ( ( 1.31 * 1.70 * ( 1.70 / 2 + 15.30 + 0.00 ) ) + ( 1.62 * 15.30 * \\ &\quad ( 15.30 / 2 + 0.00 ) ) + ( 2.75 * 0.00 * ( 0.00 / 2 ) ) ) / \\ &\quad ( 1.31 * 1.70 + 1.62 * 15.30 + 2.75 * 0.00 ) \\ &= 8.351 \text{ mm.} \end{aligned}$$

Dist from Neutral axis of c/s to inside surface of the vessel [Ci]:

 $Ci = Xbar$ 

$$= 8.351 \text{ mm.}$$

Dist from Neutral axis of c/s to extreme outside surface of the section [Co]:

$$\begin{aligned} &= -( t - CA - Xbar ) \\ &= -( 20.000 - 3.000 - 8.351 ) \\ &= -8.649 \text{ mm.} \end{aligned}$$

Moment of Inertia (Section 13-6, Equation (5)) [I]:

$$= 0.063 \text{ cm}^{**4}$$

Effective Diameter [De]:

$$\begin{aligned} &= Pitch - ( ( 6 * I ) / ( ( t - CA )^2 * (-Co) ) ) \\ &= 69.85 - ( ( 6 * 0.06 ) / ( (20.00 - 3.00 )^2 * (8.65 ) ) ) \\ &= 31.244 \text{ mm.} \end{aligned}$$

Bending Ligament Efficiency [Eb]:

$$\begin{aligned} &= Pitch - De / Pitch \\ &= 69.850 - 31.244 / 69.850 \\ &= 0.553 \end{aligned}$$

**Long-side 2 Calculations**

Effective Diameter [De]: 25.700 mm.

Membrane Ligament Efficiency [Em]:

$$\begin{aligned} &= Pitch - De / Pitch \\ &= 69.850 - 25.700 / 69.850 \\ &= 0.632 \end{aligned}$$

Bending Ligament Efficiency [Eb]:

As diameter holes are uniform  $E_b = E_m$   
 = 0.632

Dist from Neutral axis of c/s to inside surface of the vessel [Ci]:

$$= t_1 - CA / 2$$

$$= 20.000 - 3.000 / 2$$

$$= 8.500 \text{ mm.}$$

Dist from Neutral axis of c/s to extreme outside surface of the section [Co]:

$$= -( t_1 - CA ) / 2$$

$$= -( 20.000 - 3.000 ) / 2$$

$$= -8.500 \text{ mm.}$$

**Ligament Efficiency Calculations (Section 13-6, Equations (1)-(6)):**

	Em	Eb	Ci	Co
Short-side 1	0.850	0.850	8.500	-8.500
2	0.850	0.850	8.500	-8.500
Long-side 1	0.579	0.553	8.351	-8.649
2	0.632	0.632	8.500	-8.500

**Moment of Inertia of a Strip of the Vessel Wall:**

Thickness  $t_1$ ,  $I_1 = 0.0409 \text{ cm}^{*4}$   
 Thickness  $t_2$ ,  $I_2 = 0.0409 \text{ cm}^{*4}$

**Rectangular Vessel Parameters:**

Alpha =  $H / h = 0.2986$   
 $K = (I_2/I_1) * Alpha = 0.2986$

**Membrane Stress Calculations per Section 13-7**

**Membrane Stresses at Short-side 1**

Membrane Stress at Short-side 1 [Sms]:

$$= P * H / ( 2 * t_1 )$$

$$= 0.0 * 355.00 / ( 2 * 17.000 )$$

$$= 0.01 \text{ N./mm}^2$$

**Membrane Stresses at Short-side 2**

Membrane Stress at Short-side 2 [Sms]:

$$= P * H / ( 2 * t_1 )$$

$$= 0.0 * 355.00 / ( 2 * 17.000 )$$

$$= 0.01 \text{ N./mm}^2$$

**Membrane Stresses at Long-side 1**

Membrane Stress at Long-side 1 at A [Sml]:

$$= p * h / ( 2 * t_2 )$$

$$= 0.0 * 106.00 / ( 2 * 17.000 )$$

$$= 0.00 \text{ N./mm}^2$$

If  $E_m(0.579) < E(0.850)$  and  $E_b(0.553) < E(0.850)$  then  $S_{ml} = S_{ml} / E_m$

$$= 0.00 / 0.58$$

$$= 0.01 \text{ N./mm}^2$$

**Membrane Stresses at Long-side 2**

Membrane Stress at Long-side 2 at A [Sml]:

$$= p * h / ( 2 * t_2 )$$

$$= 0.0 * 106.00 / ( 2 * 17.000 )$$

$$= 0.00 \text{ N./mm}^2$$

If  $E_m(0.632) < E(0.850)$  and  $E_b(0.632) < E(0.850)$  then  $S_{ml} = S_{ml} / E_m$

$$= 0.00 / 0.63$$

$$= 0.00 \text{ N./mm}^2$$

**MEMBRANE STRESSES: Membrane Stress Calculations per Section 13-7,**

**Equations (1) and (2). (N./mm<sup>2</sup>) :**

STRESS LOCATIONS	Actual	Allowable
Short-side 1	0.01	117.22
Short-side 2	0.01	117.22
Short-side Corner	0.01	117.22
Long-side 1 at A	0.01	137.90
Long-side 2 at A	0.00	137.90
Long-side Corner	0.00	117.22

**Bending Stress Calculations per Section 13-7**

**Bending Stresses at Short-side 1**

Bending Stresses at short side 1 at N inner [Sbs\_Ni]:

$$= ( P * c ) / ( 12 * I1 ) * ( ( -1.5 * H^2 ) + ( h^2 * ( ( 1 + alpha^2 * K ) / ( 1 + K ) ) ) )$$

$$= ( 0.0 * 8.50 ) / ( 12 * 0.04 ) * ( ( -1.5 * 106.00^2 ) + ( 355.00^2 * ( ( 1 + 0.30^2 * 0.299 ) / ( 1 + 0.299 ) ) ) )$$

$$= 0.14 \text{ N./mm}^2$$

Bending Stress at short side 1 at N outer [Sbs\_No]:

$$= ( P * c ) / ( 12 * I1 ) * ( ( -1.5 * H^2 ) + ( h^2 * ( ( 1 + alpha^2 * K ) / ( 1 + K ) ) ) )$$

$$= ( 0.0 * -8.50 ) / ( 12 * 0.04 ) * ( ( -1.5 * 106.00^2 ) + ( 355.00^2 * ( ( 1 + 0.30^2 * 0.299 ) / ( 1 + 0.299 ) ) ) )$$

$$= -0.14 \text{ N./mm}^2$$

Bending Stress at short side 1 at Q inner [Sbs\_Qi]:

$$= ( P * h^2 * c ) / ( 12 * I1 ) * ( ( 1 + alpha^2 * K ) / ( 1 + K ) )$$

$$= ( 0.0 * 355.00^2 * 8.500 ) / ( 12 * 0.04 ) * ( ( 1 + 0.30^2 * 0.299 ) / ( 1 + 0.299 ) )$$

$$= 0.17 \text{ N./mm}^2$$

Bending Stress at short side 1 at Q outer [Sbs\_Qo]:

$$= ( P * h^2 * c ) / ( 12 * I1 ) * ( ( 1 + alpha^2 * K ) / ( 1 + K ) )$$

$$= ( 0.0 * 355.00^2 * -8.500 ) / ( 12 * 0.04 ) * ( ( 1 + 0.30^2 * 0.299 ) / ( 1 + 0.299 ) )$$

$$= -0.17 \text{ N./mm}^2$$

**Bending Stresses at Short-side 2**

Bending Stresses at short side 2 at N inner [Sbs\_Ni]:

$$= ( P * c ) / ( 12 * I1 ) * ( ( -1.5 * H^2 ) + ( h^2 * ( ( 1 + alpha^2 * K ) / ( 1 + K ) ) ) )$$

$$= ( 0.0 * 8.50 ) / ( 12 * 0.04 ) * ( ( -1.5 * 106.00^2 ) + ( 355.00^2 * ( ( 1 + 0.30^2 * 0.299 ) / ( 1 + 0.299 ) ) ) )$$

$$= 0.14 \text{ N./mm}^2$$

Bending Stress at short side 2 at N outer [Sbs\_No]:

$$= ( P * c ) / ( 12 * I1 ) * ( ( -1.5 * H^2 ) + ( h^2 * ( ( 1 + alpha^2 * K ) / ( 1 + K ) ) ) )$$

$$= ( 0.0 * -8.50 ) / ( 12 * 0.04 ) * ( ( -1.5 * 106.00^2 ) + ( 355.00^2 * ( ( 1 + 0.30^2 * 0.299 ) / ( 1 + 0.299 ) ) ) )$$

$$= -0.14 \text{ N./mm}^2$$

Bending Stress at short side 2 at Q inner [Sbs\_Qi]:

$$= ( P * h^2 * c ) / ( 12 * I1 ) * ( ( 1 + alpha^2 * K ) / ( 1 + K ) )$$

$$= ( 0.0 * 355.00^2 * 8.500 ) / ( 12 * 0.04 ) * ( ( 1 + 0.30^2 * 0.299 ) / ( 1 + 0.299 ) )$$

$$= 0.17 \text{ N./mm}^2$$

Bending Stress at short side 2 at Q outer [Sbs\_Qo]:

$$= ( P * h^2 * c ) / ( 12 * I1 ) * ( ( 1 + alpha^2 * K ) / ( 1 + K ) )$$

$$= ( 0.0 * 355.00^2 * -8.500 ) / ( 12 * 0.04 ) * ( ( 1 + 0.30^2 * 0.299 ) / ( 1 + 0.299 ) )$$

$$= -0.17 \text{ N./mm}^2$$

**Bending Stress at Long-side 1**

Bending Stress at long side 1 at M inner [Sbl\_Mi]:

FileName : F.V.FRONT-rev.01

Rectves Analysis : FRONT

Item: 1 1:25p Jul 20,2024

$$\begin{aligned}
 &= ( P * h^2 * c ) / ( 12 * I2 ) * ( -1.5 + ( ( 1 + \alpha^2 * K ) / ( 1 + K ) ) ) \\
 &= ( 0.0 * 355.00^2 * 8.351 ) / ( 12 * 0.04 ) * ( -1.5 + ( ( 1 + 0.30^2 * 0.299 ) / ( 1 + 0.299 ) ) ) \\
 &= -0.15 \text{ N./mm}^2
 \end{aligned}$$

If  $E_m(0.579) < E(0.850)$  and  $E_b(0.553) < E(0.850)$  then

$$\begin{aligned}
 S_{b1\_Mi} &= S_{b1\_Mi} / E_m \\
 &= -0.15 / 0.58 \\
 &= -0.27 \text{ N./mm}^2
 \end{aligned}$$

Bending Stress at long side 1 at M outer [Sbl\_Mo]:

$$\begin{aligned}
 &= ( P * h^2 * c ) / ( 12 * I2 ) * ( -1.5 + ( 1 + \alpha^2 * K ) / ( 1 + K ) ) \\
 &= ( 0.0 * 355.00^2 * -8.649 ) / ( 12 * 0.04 ) * ( -1.5 + ( 1 + 0.30^2 * 0.299 ) / ( 1 + 0.299 ) ) \\
 &= 0.16 \text{ N./mm}^2
 \end{aligned}$$

If  $E_m(0.579) < E(0.850)$  and  $E_b(0.553) < E(0.850)$  then

$$\begin{aligned}
 S_{b1\_Mo} &= S_{b1\_Mo} / E_m \\
 &= 0.16 / 0.58 \\
 &= 0.28 \text{ N./mm}^2
 \end{aligned}$$

Bending Stress at long side 1 at Q inner [Sbl\_Qi]:

$$\begin{aligned}
 &= ( P * h^2 * c ) / ( 12 * I2 ) * ( ( 1 + \alpha^2 * K ) / ( 1 + K ) ) \\
 &= ( 0.0 * 355.00^2 * 8.351 ) / ( 12 * 0.04 ) * ( ( 1 + 0.30^2 * 0.299 ) / ( 1 + 0.299 ) ) \\
 &= 0.17 \text{ N./mm}^2
 \end{aligned}$$

Bending Stress at long side 1 at Q outer [Sbl\_Qo]:

$$\begin{aligned}
 &= ( P * h^2 * c ) / ( 12 * I2 ) * ( ( 1 + \alpha^2 * K ) / ( 1 + K ) ) \\
 &= ( 0.0 * 355.00^2 * -8.649 ) / ( 12 * 0.04 ) * ( ( 1 + 0.30^2 * 0.299 ) / ( 1 + 0.299 ) ) \\
 &= -0.18 \text{ N./mm}^2
 \end{aligned}$$

### Bending Stress at Long-side 2

Bending Stress at long side 2 at M inner [Sbl\_Mi]:

$$\begin{aligned}
 &= ( P * h^2 * c ) / ( 12 * I2 ) * ( -1.5 + ( ( 1 + \alpha^2 * K ) / ( 1 + K ) ) ) \\
 &= ( 0.0 * 355.00^2 * 8.500 ) / ( 12 * 0.04 ) * ( -1.5 + ( ( 1 + 0.30^2 * 0.299 ) / ( 1 + 0.299 ) ) ) \\
 &= -0.15 \text{ N./mm}^2
 \end{aligned}$$

If  $E_m(0.632) < E(0.850)$  and  $E_b(0.632) < E(0.850)$  then

$$\begin{aligned}
 S_{b1\_Mi} &= S_{b1\_Mi} / E_m \\
 &= -0.15 / 0.63 \\
 &= -0.24 \text{ N./mm}^2
 \end{aligned}$$

Bending Stress at long side 2 at M outer [Sbl\_Mo]:

$$\begin{aligned}
 &= ( P * h^2 * c ) / ( 12 * I2 ) * ( -1.5 + ( 1 + \alpha^2 * K ) / ( 1 + K ) ) \\
 &= ( 0.0 * 355.00^2 * -8.500 ) / ( 12 * 0.04 ) * ( -1.5 + ( 1 + 0.30^2 * 0.299 ) / ( 1 + 0.299 ) ) \\
 &= 0.15 \text{ N./mm}^2
 \end{aligned}$$

If  $E_m(0.632) < E(0.850)$  and  $E_b(0.632) < E(0.850)$  then

$$\begin{aligned}
 S_{b1\_Mo} &= S_{b1\_Mo} / E_m \\
 &= 0.15 / 0.63 \\
 &= 0.24 \text{ N./mm}^2
 \end{aligned}$$

Bending Stress at long side 2 at Q inner [Sbl\_Qi]:

$$\begin{aligned}
 &= ( P * h^2 * c ) / ( 12 * I2 ) * ( ( 1 + \alpha^2 * K ) / ( 1 + K ) ) \\
 &= ( 0.0 * 355.00^2 * 8.500 ) / ( 12 * 0.04 ) * ( ( 1 + 0.30^2 * 0.299 ) / ( 1 + 0.299 ) ) \\
 &= 0.17 \text{ N./mm}^2
 \end{aligned}$$

Bending Stress at long side 2 at Q outer [Sbl\_Qo]:

$$\begin{aligned}
 &= ( P * h^2 * c ) / ( 12 * I2 ) * ( ( 1 + \alpha^2 * K ) / ( 1 + K ) ) \\
 &= ( 0.0 * 355.00^2 * -8.500 ) / ( 12 * 0.04 ) * ( ( 1 + 0.30^2 * 0.299 ) / ( 1 + 0.299 ) )
 \end{aligned}$$

$$\begin{aligned} & / ( 1 + 0.299 ) ) \\ & = -0.17 \text{ N./mm}^2 \end{aligned}$$

**BENDING STRESSES: Bending Stress Calculations per Section 13-7, Equations (3-6). (N./mm<sup>2</sup>) :**

STRESS LOCATIONS	Inner	Outer	Allowable
Short-side 1 at N	0.14	-0.14	175.82
at Q	0.17	-0.17	175.82
Short-side 2 at N	0.14	-0.14	175.82
at Q	0.17	-0.17	175.82
Long-side 1 at M	-0.27	0.28	206.85
at Q	0.17	-0.18	175.82
Long-side 2 at M	-0.24	0.24	206.85
at Q	0.17	-0.17	175.82

**Total Stress Calculations per Section 13-7**

**Total Stresses at Short-side 1**

Total Stress at short side 1 at N inner [STS\_Ni]:  
 = S<sub>ms</sub> + S<sub>bs\_Ni</sub>  
 = 0.01 + 0.14  
 = 0.15 N./mm<sup>2</sup>

Total Stress at short side 1 at N outer [STS\_No]:  
 = S<sub>ms</sub> + S<sub>bs\_No</sub>  
 = 0.01 + -0.14  
 = -0.13 N./mm<sup>2</sup>

Total Stress at short side 1 at Q inner [STS\_Qi]:  
 = S<sub>ms</sub> + S<sub>bs\_Qi</sub>  
 = 0.01 + 0.17  
 = 0.18 N./mm<sup>2</sup>

Total Stress at short side 1 at Q outer [STS\_Qo]:  
 = S<sub>ms</sub> + S<sub>b\_Qo</sub>  
 = 0.01 + -0.17  
 = -0.16 N./mm<sup>2</sup>

**Total Stresses at Short-side 2**

Total Stress at short side 2 at N inner [STS\_Ni]:  
 = S<sub>ms</sub> + S<sub>bs\_Ni</sub>  
 = 0.01 + 0.14  
 = 0.15 N./mm<sup>2</sup>

Total Stress at short side 2 at N outer [STS\_No]:  
 = S<sub>ms</sub> + S<sub>bs\_No</sub>  
 = 0.01 + -0.14  
 = -0.13 N./mm<sup>2</sup>

Total Stress at short side 2 at Q inner [STS\_Qi]:  
 = S<sub>ms</sub> + S<sub>bs\_Qi</sub>  
 = 0.01 + 0.17  
 = 0.18 N./mm<sup>2</sup>

Total Stress at short side 2 at Q outer [STS\_Qo]:  
 = S<sub>ms</sub> + S<sub>b\_Qo</sub>  
 = 0.01 + -0.17  
 = -0.16 N./mm<sup>2</sup>

**Total Stresses at Long-side 1**

Total Stress at long side 1 at M inner [STL\_Mi]:  
 = S<sub>m1</sub> + S<sub>b1\_Mi</sub>  
 = 0.01 + -0.27  
 = -0.27 N./mm<sup>2</sup>

Total Stress at long side 1 at M outer [STL\_Mo]:

= Sml + Sb\_Mo  
 = 0.01 + 0.28  
 = 0.29 N./mm<sup>2</sup>

Total Stress at long side 1 at Q inner [STL\_Qi]:  
 = Sml + Sbl\_Qi  
 = 0.01 + 0.17  
 = 0.17 N./mm<sup>2</sup>

Total Stress at long side 1 at Q outer [STL\_Qo]:  
 = Sml + Sb\_Qo  
 = 0.01 + -0.18  
 = -0.17 N./mm<sup>2</sup>

**Total Stresses at Long-side 2**

Total Stress at long side 2 at M inner [STL\_Mi]:  
 = Sml + Sbl\_Mi  
 = 0.00 + -0.24  
 = -0.24 N./mm<sup>2</sup>

Total Stress at long side 2 at M outer [STL\_Mo]:  
 = Sml + Sb\_Mo  
 = 0.00 + 0.24  
 = 0.25 N./mm<sup>2</sup>

Total Stress at long side 2 at Q inner [STL\_Qi]:  
 = Sml + Sbl\_Qi  
 = 0.00 + 0.17  
 = 0.18 N./mm<sup>2</sup>

Total Stress at long side 2 at Q outer [STL\_Qo]:  
 = Sml + Sb\_Qo  
 = 0.00 + -0.17  
 = -0.17 N./mm<sup>2</sup>

**TOTAL STRESSES: Total Stress Calculations per Section 13-7, Equations (7-10). (N./mm<sup>2</sup>) :**

STRESS LOCATIONS	Inner	Outer	Allowable
Short-side 1 at N	0.15	-0.13	175.82
at Q	0.18	-0.16	175.82
Short-side 2 at N	0.15	-0.13	175.82
at Q	0.18	-0.16	175.82
Long-side 1 at M	-0.27	0.29	206.85
at Q	0.17	-0.17	175.82
Long-side 2 at M	-0.24	0.25	206.85
at Q	0.18	-0.17	175.82

**END PLATE STRESSES (N./mm<sup>2</sup>) :**

	Actual	Allowable
End Plate	0.02	137.90

**SUMMARY OF RESULTS (INTERNAL PRESSURE):**

**MEMBRANE STRESS SUMMARY,**

High Stress (Highest % of Allowable)	0.01	N./mm <sup>2</sup>
High Stress Percentage	0.01	%
M.A.W.P. for Membrane Stresses	112.26	bars

**BENDING STRESS SUMMARY,**

High Stress (Highest % of Allowable)	0.28	N./mm <sup>2</sup>
High Stress Percentage	0.14	%
M.A.W.P. for Bending Stresses	7.26	bars

**TOTAL STRESS SUMMARY,**

High Stress (Highest % of Allowable)	0.29	N./mm <sup>2</sup>
High Stress Percentage	0.14	%
M.A.W.P. for Total Stresses	7.13	bars

**Internal Pressure Results, Rect. Vessel # 1, Desc: FRONT**  
**ASME Code, Section VIII, Division 1, 2017 App. 13**

**Ligament Efficiency Calculations (Section 13-6, Equations (1)-(6)):**

**Short-side 1 Calculations**

Membrane Ligament Efficiency [Em]:  
 = 0.850

Bending Ligament Efficiency [Eb]:  
 = 0.850

Dist from Neutral axis of c/s to inside surface of the vessel [Ci]:  
 =  $t_1 - CA / 2$   
 =  $20.000 - 3.000 / 2$   
 = 8.500 mm.

Dist from Neutral axis of c/s to extreme outside surface of the section [Co]:  
 =  $-(t_1 - CA) / 2$   
 =  $-(20.000 - 3.000) / 2$   
 = -8.500 mm.

**Short-side 2 Calculations**

Membrane Ligament Efficiency [Em]:  
 = 0.850

Bending Ligament Efficiency [Eb]:  
 = 0.850

Dist from Neutral axis of c/s to inside surface of the vessel [Ci]:  
 =  $t_1 - CA / 2$   
 =  $20.000 - 3.000 / 2$   
 = 8.500 mm.

Dist from Neutral axis of c/s to extreme outside surface of the section [Co]:  
 =  $-(t_1 - CA) / 2$   
 =  $-(20.000 - 3.000) / 2$   
 = -8.500 mm.

**Long-side 1 Calculations**

Effective Diameter [De]:  
 =  $(d_0 * T_0 + d_1 * T_1 + d_2 * T_2) / (t_1 - CA)$   
 =  $(36.50 * 1.70 + 28.60 * 12.30 + 0.00 * 0.00) /$   
 $(20.00 - 3.00)$   
 = 24.343 mm.

Membrane Ligament Efficiency [Em]:  
 =  $Pitch - De / Pitch$   
 =  $69.850 - 24.343 / 69.850$   
 = 0.651

Dist from Neutral axis of c/s to extreme fibers [Ci & Co]:

**Calculation of Xbar:**

$$= ((b_0 * T_0 * (T_0/2 + T_1 + T_2)) + (b_1 * T_1 * (T_1/2 + T_2)) + (b_2 * T_2 * (T_2/2))) / (b_0 * T_0 + b_1 * T_1 + b_2 * T_2)$$

$$= ((1.31 * 1.70 * (1.70 / 2 + 12.30 + 0.00)) + (1.62 * 12.30 * (12.30 / 2 + 0.00)) + (2.75 * 0.00 * (0.00 / 2))) / (1.31 * 1.70 + 1.62 * 12.30 + 2.75 * 0.00)$$

$$= 6.854 \text{ mm.}$$

Dist from Neutral axis of c/s to inside surface of the vessel [Ci]:  
 $Ci = Xbar$   
 = 6.854 mm.

Dist from Neutral axis of c/s to extreme outside surface of the section [Co]:

$$= -(t - CA - Xbar)$$

$$= -(20.000 - 3.000 - 6.854)$$

$$= -10.146 \text{ mm.}$$

Moment of Inertia (Section 13-6, Equation (5)) [I]:

$$= 0.035 \text{ cm}^4$$

Effective Diameter [De]:

$$= Pitch - ((6 * I) / ((t - CA)^2 * (-Co)))$$

$$= 69.85 - ((6 * 0.04) / ((20.00 - 3.00)^2 * (10.15)))$$

$$= 51.620 \text{ mm.}$$

Bending Ligament Efficiency [Eb]:

$$= Pitch - De / Pitch$$

$$= 69.850 - 51.620 / 69.850$$

$$= 0.261$$

**Long-side 2 Calculations**

Effective Diameter [De]: 25.700 mm.

Membrane Ligament Efficiency [Em]:

$$= Pitch - De / Pitch$$

$$= 69.850 - 25.700 / 69.850$$

$$= 0.632$$

Bending Ligament Efficiency [Eb]:

As diameter holes are uniform  $E_b = E_m$

$$= 0.632$$

Dist from Neutral axis of c/s to inside surface of the vessel [Ci]:

$$= t1 - CA / 2$$

$$= 20.000 - 3.000 / 2$$

$$= 8.500 \text{ mm.}$$

Dist from Neutral axis of c/s to extreme outside surface of the section [Co]:

$$= -(t1 - CA) / 2$$

$$= -(20.000 - 3.000) / 2$$

$$= -8.500 \text{ mm.}$$

**Ligament Efficiency Calculations (Section 13-6, Equations (1)-(6)):**

	Em	Eb	Ci	Co
Short-side 1	0.850	0.850	8.500	-8.500
2	0.850	0.850	8.500	-8.500
Long-side 1	0.651	0.261	6.854	-10.146
2	0.632	0.632	8.500	-8.500

**Moment of Inertia of a Strip of the Vessel Wall:**

$$\text{Thickness } t1, I1 = 0.0409 \text{ cm}^4$$

$$\text{Thickness } t2, I2 = 0.0409 \text{ cm}^4$$

**Rectangular Vessel Parameters:**

$$\text{Alpha} = H / h = 0.2986$$

$$K = (I2/I1) * \text{Alpha} = 0.2986$$

**Membrane Stress Calculations per Section 13-7**

**Membrane Stresses at Short-side 1**

Membrane Stress at Short-side 1 [Sms]:

$$= P * H / (2 * t1)$$

$$= 1.0 * 355.00 / (2 * 17.000)$$

$$= 1.04 \text{ N./mm}^2$$

**Membrane Stresses at Short-side 2**

Membrane Stress at Short-side 2 [Sms]:

$$= P * H / ( 2 * t1 )$$

$$= 1.0 * 355.00 / ( 2 * 17.000 )$$

$$= 1.04 \text{ N./mm}^2$$

**Membrane Stresses at Long-side 1**

Membrane Stress at Long-side 1 at A [Sml]:

$$= p * h / ( 2 * t2 )$$

$$= 1.0 * 106.00 / ( 2 * 17.000 )$$

$$= 0.31 \text{ N./mm}^2$$

If  $E_m(0.651) < E(0.850)$  and  $E_b(0.261) < E(0.850)$  then  $Sml = Sml / Em$

$$= 0.31 / 0.65$$

$$= 0.48 \text{ N./mm}^2$$

**Membrane Stresses at Long-side 2**

Membrane Stress at Long-side 2 at A [Sml]:

$$= p * h / ( 2 * t2 )$$

$$= 1.0 * 106.00 / ( 2 * 17.000 )$$

$$= 0.31 \text{ N./mm}^2$$

If  $E_m(0.632) < E(0.850)$  and  $E_b(0.632) < E(0.850)$  then  $Sml = Sml / Em$

$$= 0.31 / 0.63$$

$$= 0.49 \text{ N./mm}^2$$

**MEMBRANE STRESSES: Membrane Stress Calculations per Section 13-7, Equations (1) and (2). (N./mm<sup>2</sup>) :**

STRESS LOCATIONS	Actual	Allowable
Short-side 1	1.04	117.22
Short-side 2	1.04	117.22
Short-side Corner	1.04	117.22
Long-side 1 at A	0.48	137.90
Long-side 2 at A	0.49	137.90
Long-side Corner	0.31	117.22

**Bending Stress Calculations per Section 13-7**

**Bending Stresses at Short-side 1**

Bending Stresses at short side 1 at N inner [Sbs\_Ni]:

$$= ( P * c ) / ( 12 * I1 ) * ( ( -1.5 * H^2 ) + ( h^2 * ( ( 1 + \alpha^2 * K ) / ( 1 + K ) ) ) )$$

$$= ( 1.0 * 8.50 ) / ( 12 * 0.04 ) * ( ( -1.5 * 106.00^2 ) + ( 355.00^2 * ( ( 1 + 0.30^2 * 0.299 ) / ( 1 + 0.299 ) ) ) )$$

$$= 14.32 \text{ N./mm}^2$$

Bending Stress at short side 1 at N outer [Sbs\_No]:

$$= ( P * c ) / ( 12 * I1 ) * ( ( -1.5 * H^2 ) + ( h^2 * ( ( 1 + \alpha^2 * K ) / ( 1 + K ) ) ) )$$

$$= ( 1.0 * -8.50 ) / ( 12 * 0.04 ) * ( ( -1.5 * 106.00^2 ) + ( 355.00^2 * ( ( 1 + 0.30^2 * 0.299 ) / ( 1 + 0.299 ) ) ) )$$

$$= -14.32 \text{ N./mm}^2$$

Bending Stress at short side 1 at Q inner [Sbs\_Qi]:

$$= ( P * h^2 * c ) / ( 12 * I1 ) * ( ( 1 + \alpha^2 * K ) / ( 1 + K ) )$$

$$= ( 1.0 * 355.00^2 * 8.500 ) / ( 12 * 0.04 ) * ( ( 1 + 0.30^2 * 0.299 ) / ( 1 + 0.299 ) )$$

$$= 17.24 \text{ N./mm}^2$$

Bending Stress at short side 1 at Q outer [Sbs\_Qo]:

$$= ( P * h^2 * c ) / ( 12 * I1 ) * ( ( 1 + \alpha^2 * K ) / ( 1 + K ) )$$

$$= ( 1.0 * 355.00^2 * -8.500 ) / ( 12 * 0.04 ) * ( ( 1 + 0.30^2 * 0.299 ) / ( 1 + 0.299 ) )$$

$$= -17.24 \text{ N./mm}^2$$

**Bending Stresses at Short-side 2**

Bending Stresses at short side 2 at N inner [Sbs\_Ni]:

$$= ( P * c ) / ( 12 * I1 ) * ( ( -1.5 * H^2 ) +$$

$$\begin{aligned}
 & ( h^2 * ( ( 1 + \alpha^2 * K ) / ( 1 + K ) ) ) \\
 = & ( 1.0 * 8.50 ) / ( 12 * 0.04 ) * ( ( -1.5 * 106.00^2 ) + \\
 & ( 355.00^2 * ( ( 1 + 0.30^2 * 0.299 ) / ( 1 + 0.299 ) ) ) ) \\
 = & 14.32 \text{ N./mm}^2
 \end{aligned}$$

Bending Stress at short side 2 at N outer [Sbs\_No]:

$$\begin{aligned}
 = & ( P * c ) / ( 12 * I1 ) * ( ( -1.5 * H^2 ) + \\
 & ( h^2 * ( ( 1 + \alpha^2 * K ) / ( 1 + K ) ) ) ) \\
 = & ( 1.0 * -8.50 ) / ( 12 * 0.04 ) * ( ( -1.5 * 106.00^2 ) + \\
 & ( 355.00^2 * ( ( 1 + 0.30^2 * 0.299 ) / ( 1 + 0.299 ) ) ) ) \\
 = & -14.32 \text{ N./mm}^2
 \end{aligned}$$

Bending Stress at short side 2 at Q inner [Sbs\_Qi]:

$$\begin{aligned}
 = & ( P * h^2 * c ) / ( 12 * I1 ) * ( ( 1 + \alpha^2 * K ) / ( 1 + K ) ) \\
 = & ( 1.0 * 355.00^2 * 8.500 ) / ( 12 * 0.04 ) * ( ( 1 + 0.30^2 * 0.299 ) / \\
 & ( 1 + 0.299 ) ) \\
 = & 17.24 \text{ N./mm}^2
 \end{aligned}$$

Bending Stress at short side 2 at Q outer [Sbs\_Qo]:

$$\begin{aligned}
 = & ( P * h^2 * c ) / ( 12 * I1 ) * ( ( 1 + \alpha^2 * K ) / ( 1 + K ) ) \\
 = & ( 1.0 * 355.00^2 * -8.500 ) / ( 12 * 0.04 ) * ( ( 1 + 0.30^2 * 0.299 ) / \\
 & ( 1 + 0.299 ) ) \\
 = & -17.24 \text{ N./mm}^2
 \end{aligned}$$

**Bending Stress at Long-side 1**

Bending Stress at long side 1 at M inner [Sbl\_Mi]:

$$\begin{aligned}
 = & ( P * h^2 * c ) / ( 12 * I2 ) * ( -1.5 + ( ( 1 + \alpha^2 * K ) / \\
 & ( 1 + K ) ) ) \\
 = & ( 1.0 * 355.00^2 * 6.854 ) / ( 12 * 0.04 ) * ( -1.5 + ( ( 1 + 0.30^2 * \\
 & 0.299 ) / ( 1 + 0.299 ) ) ) \\
 = & -12.47 \text{ N./mm}^2
 \end{aligned}$$

If  $E_m(0.651) < E(0.850)$  and  $E_b(0.261) < E(0.850)$  then

$$\begin{aligned}
 Sbl\_Mi &= Sbl\_Mi / E_m \\
 = & -12.47 / 0.65 \\
 = & -47.79 \text{ N./mm}^2
 \end{aligned}$$

Bending Stress at long side 1 at M outer [Sbl\_Mo]:

$$\begin{aligned}
 = & ( P * h^2 * c ) / ( 12 * I2 ) * ( -1.5 + ( 1 + \alpha^2 * K ) / \\
 & ( 1 + K ) ) \\
 = & ( 1.0 * 355.00^2 * -10.146 ) / ( 12 * 0.04 ) * ( -1.5 + ( 1 + 0.30^2 * \\
 & 0.299 ) / ( 1 + 0.299 ) ) \\
 = & 18.47 \text{ N./mm}^2
 \end{aligned}$$

If  $E_m(0.651) < E(0.850)$  and  $E_b(0.261) < E(0.850)$  then

$$\begin{aligned}
 Sbl\_Mo &= Sbl\_Mo / E_m \\
 = & 18.47 / 0.65 \\
 = & 70.75 \text{ N./mm}^2
 \end{aligned}$$

Bending Stress at long side 1 at Q inner [Sbl\_Qi]:

$$\begin{aligned}
 = & ( P * h^2 * c ) / ( 12 * I2 ) * ( ( 1 + \alpha^2 * K ) / ( 1 + K ) ) \\
 = & ( 1.0 * 355.00^2 * 6.854 ) / ( 12 * 0.04 ) * ( ( 1 + 0.30^2 * 0.299 ) / \\
 & ( 1 + 0.299 ) ) \\
 = & 13.90 \text{ N./mm}^2
 \end{aligned}$$

Bending Stress at long side 1 at Q outer [Sbl\_Qo]:

$$\begin{aligned}
 = & ( P * h^2 * c ) / ( 12 * I2 ) * ( ( 1 + \alpha^2 * K ) / ( 1 + K ) ) \\
 = & ( 1.0 * 355.00^2 * -10.146 ) / ( 12 * 0.04 ) * ( ( 1 + 0.30^2 * 0.299 ) \\
 & / ( 1 + 0.299 ) ) \\
 = & -20.58 \text{ N./mm}^2
 \end{aligned}$$

**Bending Stress at Long-side 2**

Bending Stress at long side 2 at M inner [Sbl\_Mi]:

$$\begin{aligned}
 = & ( P * h^2 * c ) / ( 12 * I2 ) * ( -1.5 + ( ( 1 + \alpha^2 * K ) / \\
 & ( 1 + K ) ) ) \\
 = & ( 1.0 * 355.00^2 * 8.500 ) / ( 12 * 0.04 ) * ( -1.5 + ( ( 1 + 0.30^2 * \\
 & 0.299 ) / ( 1 + 0.299 ) ) ) \\
 = & -15.47 \text{ N./mm}^2
 \end{aligned}$$

If  $E_m(0.632) < E(0.850)$  and  $E_b(0.632) < E(0.850)$  then

$$\begin{aligned} S_{bl\_Mi} &= S_{bl\_Mi} / E_m \\ &= -15.47 / 0.63 \\ &= -24.47 \text{ N./mm}^2 \end{aligned}$$

Bending Stress at long side 2 at M outer [Sbl\_Mo]:

$$\begin{aligned} &= ( P * h^2 * c ) / ( 12 * I_2 ) * ( -1.5 + ( 1 + \alpha^2 * K ) / ( 1 + K ) ) \\ &= ( 1.0 * 355.00^2 * -8.500 ) / ( 12 * 0.04 ) * ( -1.5 + ( 1 + 0.30^2 * 0.299 ) / ( 1 + 0.299 ) ) \\ &= 15.47 \text{ N./mm}^2 \end{aligned}$$

If  $E_m(0.632) < E(0.850)$  and  $E_b(0.632) < E(0.850)$  then

$$\begin{aligned} S_{bl\_Mo} &= S_{bl\_Mo} / E_m \\ &= 15.47 / 0.63 \\ &= 24.47 \text{ N./mm}^2 \end{aligned}$$

Bending Stress at long side 2 at Q inner [Sbl\_Qi]:

$$\begin{aligned} &= ( P * h^2 * c ) / ( 12 * I_2 ) * ( ( 1 + \alpha^2 * K ) / ( 1 + K ) ) \\ &= ( 1.0 * 355.00^2 * 8.500 ) / ( 12 * 0.04 ) * ( ( 1 + 0.30^2 * 0.299 ) / ( 1 + 0.299 ) ) \\ &= 17.24 \text{ N./mm}^2 \end{aligned}$$

Bending Stress at long side 2 at Q outer [Sbl\_Qo]:

$$\begin{aligned} &= ( P * h^2 * c ) / ( 12 * I_2 ) * ( ( 1 + \alpha^2 * K ) / ( 1 + K ) ) \\ &= ( 1.0 * 355.00^2 * -8.500 ) / ( 12 * 0.04 ) * ( ( 1 + 0.30^2 * 0.299 ) / ( 1 + 0.299 ) ) \\ &= -17.24 \text{ N./mm}^2 \end{aligned}$$

**BENDING STRESSES: Bending Stress Calculations per Section 13-7, Equations (3-6). (N./mm<sup>2</sup>) :**

STRESS LOCATIONS	Inner	Outer	Allowable
Short-side 1 at N	14.32	-14.32	175.82
at Q	17.24	-17.24	175.82
Short-side 2 at N	14.32	-14.32	175.82
at Q	17.24	-17.24	175.82
Long-side 1 at M	-47.79	70.75	206.85
at Q	13.90	-20.58	175.82
Long-side 2 at M	-24.47	24.47	206.85
at Q	17.24	-17.24	175.82

**Total Stress Calculations per Section 13-7**

**Total Stresses at Short-side 1**

Total Stress at short side 1 at N inner [STS\_Ni]:

$$\begin{aligned} &= S_{ms} + S_{bs\_Ni} \\ &= 1.04 + 14.32 \\ &= 15.37 \text{ N./mm}^2 \end{aligned}$$

Total Stress at short side 1 at N outer [STS\_No]:

$$\begin{aligned} &= S_{ms} + S_{bs\_No} \\ &= 1.04 + -14.32 \\ &= -13.28 \text{ N./mm}^2 \end{aligned}$$

Total Stress at short side 1 at Q inner [STS\_Qi]:

$$\begin{aligned} &= S_{ms} + S_{bs\_Qi} \\ &= 1.04 + 17.24 \\ &= 18.28 \text{ N./mm}^2 \end{aligned}$$

Total Stress at short side 1 at Q outer [STS\_Qo]:

$$\begin{aligned} &= S_{ms} + S_{bs\_Qo} \\ &= 1.04 + -17.24 \\ &= -16.19 \text{ N./mm}^2 \end{aligned}$$

**Total Stresses at Short-side 2**

Total Stress at short side 2 at N inner [STS\_Ni]:



PV Elite 2019 SP1 Licensee: SL Client

FileName : F.V.FRONT-rev.01

Rectves Analysis : FRONT

Item: 1 1:25p Jul 20,2024

	at Q	18.28	-16.19	175.82
Long-side	1 at M	-47.31	71.23	206.85
	at Q	14.38	-20.10	175.82
Long-side	2 at M	-23.98	24.97	206.85
	at Q	17.73	-16.74	175.82

**END PLATE STRESSES (N./mm<sup>2</sup>) :**

	Actual	Allowable
End Plate	1.94	137.90

**PLATE STABILITY CALCULATIONS PER SECTION 13-14(b) (N./mm<sup>2</sup>) :**

Plate Buckling Coefficients (Fig. 13-14(a)):

$$KA = 5.53$$

$$KB = 14.33$$

**Stress Calculations per Section 13-15****Stresses at Short side plates**

Membrane Stress at Short-side at A [SmsA]:

$$= Pe * h * H / ( 2 * ( t1 * H + t2 * h ) )$$

$$= 1.00 * 355.00 * 106.00 / ( 2 * ( 17.00 * 106.00 + 10.75 * 355.00 ) )$$

$$= 0.34 \text{ N./mm}^2$$

Membrane Stress at Short-side at B [SmsB]:

$$= Pe * h / ( 2 * t1 )$$

$$= 1.00 * 355.00 / ( 2 * 17.00 )$$

$$= 1.04 \text{ N./mm}^2$$

Buckling Stress at Short-side at A [ScrsA]:

$$= ( Pi^2 * E2 / ( 12 * ( 1 - \nu^2 ) ) ) * ( t1 / H )^2 * KA$$

$$= ( 3.14^2 * 196921.88 / ( 12 * ( 1 - 0.3^2 ) ) ) * ( 17.00 / 106.00 )^2 * 5.53$$

$$= 25316.12 \text{ N./mm}^2$$

Buckling Stress at Short-side at B [ScrsB]:

$$= Pi^2 * E2 / ( 12 * ( 1 - \nu^2 ) ) * ( t1 / Lv )^2 * KB$$

$$= 3.14^2 * 196921.88 / ( 12 * ( 1 - 0.3^2 ) ) * ( 17.00 / 2510.00 )^2 * 14.33$$

$$= 116.97 \text{ N./mm}^2$$

**Stresses at Long side plates**

Membrane Stress at Long-side at A [SmlA]:

$$= Pe * h * H / ( 2 * ( t1 * H + t2 * H ) )$$

$$= 1.00 * 355.00 * 106.00 / ( 2 * ( 17.00 * 106.00 + 10.75 * 106.00 ) )$$

$$= 0.34 \text{ N./mm}^2$$

Membrane Stress at Long-side at B [SmIB]:

$$= Pe * h / ( 2 * t2 )$$

$$= 1.00 * 355.00 / ( 2 * 10.75 )$$

$$= 0.49 \text{ N./mm}^2$$

Buckling Stress at Long-side at A [ScrlA]:

$$= Pi^2 * E2 / ( 12 * ( 1 - \nu^2 ) ) * ( t2 / H )^2 * KA$$

$$= 3.14^2 * 196921.88 / ( 12 * ( 1 - 0.3^2 ) ) * ( 10.75 / 106.00 )^2 * 5.53$$

$$= 2257.11 \text{ N./mm}^2$$

**ScrlA(2257.107) > 0.5 \* Sy(235.976)**

$$= Sy - ( Sy^2 / ( 4 * ScrlA ) )$$

$$= 235.98 - ( 235.98^2 / ( 4 * 2257.11 ) )$$

$$= 229.81 \text{ N./mm}^2$$

Buckling Stress at Long-side at B [ScrlB]:

$$= Pi^2 * E2 / ( 12 * ( 1 - \nu^2 ) ) * ( t2 / Lv )^2 * KB$$

$$= 3.14^2 * 196921.88 / ( 12 * ( 1 - 0.3^2 ) ) * ( 17.00 / 2510.00 )^2 * 14.33$$

$$= 116.97 \text{ N./mm}^2$$

**Stresses at End plates**

Membrane Stress at End plate at A [SmeA]:

FileName : F.V.FRONT-rev.01

Rectves Analysis : FRONT

Item: 1 1:25p Jul 20,2024

$$= Pe * H * Lv / ( 2 * ( t2 * Lv + t5 * H ) )$$

$$= 1.00 * 106.00 * 2510.00 / ( 2 * ( 10.75 * 2510.00 + 17.00 * 106.00 ) )$$

$$= 0.46 \text{ N./mm}^2$$

Membrane Stress at End plate at B [SmeB]:

$$= Pe * h * Lv / ( 2 * ( t1 * Lv + t5 * h ) )$$

$$= 1.00 * 355.00 * 2510.00 / ( 2 * ( 17.00 * 2510.00 + 17.00 * 355.00 ) )$$

$$= 0.91 \text{ N./mm}^2$$

Buckling Stress at End plate at A [ScreA]:

$$= Pi^2 * E2 / ( 12 * ( 1 - v^2 ) * ( t5 / H )^2 * KA$$

$$= 3.14^2 * 196921.88 / ( 12 * ( 1 - 0.3^2 ) * ( 17.00 / 106.00 )^2 * 5.53$$

$$= 25316.12 \text{ N./mm}^2$$

ScreA( 25316.121 ) > 0.5 \* Sy ( 235.976 )

$$= Sy - ( Sy^2 / ( 4 * ScreA ) )$$

$$= 235.98 - ( 235.98^2 / ( 4 * 25316.12 ) )$$

$$= 235.43 \text{ N./mm}^2$$

Buckling Stress at End plate at B [ScreB]:

$$= Pi^2 * E2 / ( 12 * ( 1 - v^2 ) * ( t5 / Lv )^2 * KB$$

$$= 3.14^2 * 196921.88 / ( 12 * ( 1 - 0.3^2 ) * ( 17.00 / 355.00 )^2 * 14.33$$

$$= 5847.37 \text{ N./mm}^2$$

ScreB( 5847.365 ) > 0.5 \* Sy ( 235.976 )

$$= Sy - ( Sy^2 / ( 4 * ScreB ) )$$

$$= 235.98 - ( 235.98^2 / ( 4 * 5847.37 ) )$$

$$= 233.60 \text{ N./mm}^2$$

**SUMMARY OF STRESSES PER SECTION 13-14**

Plate(s)	SMA	SMB	SCRA	SCRB	EQN(1)	P/F
Short-sides	0.34	1.04	235.43	116.97	0.021	PASS
Long-sides	0.34	0.49	229.81	116.97	0.011	PASS
End Plates	0.46	0.91	235.43	233.60	0.012	PASS

**CROSS-SECTION STABILITY CALCULATIONS PER SECTION 13-14(c)**

Dist from Outside Surface of Long-side Plate to Vessel Centroid [Yc]:

$$= 70.00 \text{ mm.}$$

Dist from Geometric Center of End Plate to Vessel Centroid [Ybar]:

$$= 0.00 \text{ mm.}$$

Moment of Inertia of Cross Section about Axis Parallel to Long-side and Passing through Vessel Centroid [Ie]:

$$= 5371.71 \text{ cm}^4$$

Least Radius of Gyration of Cross Section [RG]:

$$= \text{Min}( 0.289 * \text{Sqrt}[ Ho^2 + H^2 ] , 0.289 * \text{Sqrt}[ ho^2 + h^2 ] )$$

$$= \text{Min}( 0.289 * \text{Sqrt}[ 140.00^2 + 106.00^2 ] , 0.289 * \text{Sqrt}[ 389.00^2 + 355.00^2 ] )$$

$$= \text{Min}( 50.75 , 152.20 )$$

$$= 50.75 \text{ mm.}$$

Bending Moment of Cross Section (Equation 19) [M]:

$$= Pe * Ho * ho * YBar$$

$$= 1.00 * 389.00 * 140.00 * 0.00$$

$$= 0.00 \text{ Kg-m.}$$

Axial Stress (Eqn 15) [Sa]:

$$= Pe * ho * Ho / ( 2 * ( t1 * Ho + t2 * ho ) )$$

$$= 1.00 * 389.00 * 140.00 / ( 2 * ( 17.00 * 389.00 + 17.00 * 140.00 ) )$$

$$= 0.30 \text{ N./mm}^2$$

Bending Stress (Eqn 18) [Sb]:

$$= ( M * c ) / Ie$$

$$= ( 0.00 * 70.00 ) / 3278.02$$

$$= 0.00 \text{ N./mm}^2$$

Axial Allowed Compressive Stress (Eqn 16A) [Fa]:

FileName : F.V.FRONT-rev.01

Rectves Analysis : FRONT

Item: 1 1:25p Jul 20,2024

$$= [ 1 - (( 2 * L1 * R1 / ( 2 * Cc^2)))] * Sy / (( 5 / 3 ) + ( 3 * ( 2 * L1 / R1 ) / ( 8 * Cc )) - (( 2 * L1 / R1 )^3 / ( 8 * Cc^3)))$$

$$= [ 1 - (( 2 * 2510.00 * 50.75 / ( 2 * 128.34^2)))] * 235.98 / (( 5 / 3 ) + ( 3 * ( 2 * 2510.00 / 50.75 ) / ( 8 * 128.34 )) - (( 2 * 2510.00 / 50.75 )^3 / ( 8 * 128.34^3)))$$

$$= 87.38 \text{ N./mm}^2$$

Euler Stress Divided by Factor of Safety (Eqn 20) [Fpe]:

$$= 12 * pi^2 * E / ( 23 * ( 2 * L1 / R1 )^2)$$

$$= 12 * 3.14^2 * 196921.88 / ( 23 * ( 2 * 2510.00 / 50.75 )^2)$$

$$= 103.63 \text{ N./mm}^2$$

Column Stability Check per Equation 14

$$= Sa / Fa + Sb / [( 1 - Sa / Fpe ) * S ]$$

$$= 0.30 / 87.38 + 0.00 / [( 1 - 0.30 / 103.63 ) * 137.90 ]$$

$$= 0.003$$

Check Passes [must be < 1.0]

**SUMMARY OF RESULTS (EXTERNAL PRESSURE):**

**MEMBRANE STRESS SUMMARY,**

High Stress (Highest % of Allowable)	1.04	N./mm <sup>2</sup>
High Stress Percentage	0.89	%
M.A.W.P. for Membrane Stresses	112.26	bars

**BENDING STRESS SUMMARY,**

High Stress (Highest % of Allowable)	70.75	N./mm <sup>2</sup>
High Stress Percentage	34.21	%
M.A.W.P. for Bending Stresses	2.92	bars

**TOTAL STRESS SUMMARY,**

High Stress (Highest % of Allowable)	71.23	N./mm <sup>2</sup>
High Stress Percentage	34.44	%
M.A.W.P. for Total Stresses	2.90	bars

**SUMMARY OF COLUMN STABILITY CHECKS:**

Plate Stability Checks	(Equation 1)	PASS
Cross Section Stability Check	(Equation 14)	PASS

PV Elite is a trademark of Intergraph CADWorx & Analysis Solutions, Inc. 2019

**Rectangular Vessel Results For Item 1 : A1**

**SUMMARY OF RESULTS (EXTERNAL PRESSURE):**

**MEMBRANE STRESS SUMMARY,**

High Stress (Highest % of Allowable)	1.04	N./mm <sup>2</sup>
High Stress Percentage	0.89	%
M.A.W.P. for Membrane Stresses	112.26	bars

**BENDING STRESS SUMMARY,**

High Stress (Highest % of Allowable)	70.75	N./mm <sup>2</sup>
High Stress Percentage	34.21	%
M.A.W.P. for Bending Stresses	2.92	bars

**TOTAL STRESS SUMMARY,**

High Stress (Highest % of Allowable)	71.23	N./mm <sup>2</sup>
High Stress Percentage	34.44	%
M.A.W.P. for Total Stresses	2.90	bars

**SUMMARY OF COLUMN STABILITY CHECKS:**

Plate Stability Checks	(Equation 1)	PASS
Cross Section Stability Check	(Equation 14)	PASS

**Input Echo, COMPONENT 1, Description: REAR**

Figure Number Analyzed		A1	
Design Internal Pressure	P	0.0100	bars
Design External Pressure	Pext	1.0000	bars
Design Temperature	Temp	120.0000	C
VESSEL MATERIAL DATA:			
Material Specification		SA-516 70	
Shell Allowable Stress at Design Temp	S	137.9000	N./mm^2
Shell Allowable Stress at Ambient	SA	137.9000	N./mm^2
Shell Yield Stress at Design Temperature	Sy	235.9761	N./mm^2
Length of Vessel	Lv	2510.0000	mm.
SHORT-SIDE VESSEL DATA:			
Short-side Length Dimension	H	100.0000	mm.
Minimum Thickness of Short-side Plates	t1	20.0000	mm.
Mid-side Joint Efficiency on Short-side	E	0.8500	
Corner Joint Efficiency on Short-side	EC	0.8500	
LONG-SIDE VESSEL DATA:			
Long-side Length Dimension	h	288.0000	mm.
Minimum Thickness of Long-side Plates	t2	20.0000	mm.
Mid-side Joint Efficiency on Long-side	E	0.8500	
ADDITIONAL VESSEL DATA:			
Minimum Thickness of End Plate	t5	20.0000	mm.
C-Factor for End Plate	Cf_Epl	0.2000	
Corrosion Allowance of Shell	CA	3.0000	mm.
Long-side Plate # 1,			
Pitch Distance	p	69.8500	mm.
# 1: Hole Diameter	d0	36.5000	mm.
Hole Depth	T0	1.7000	mm.
# 2: Hole Diameter	d1	28.6000	mm.
Hole Depth	T1	18.3000	mm.
Long-side Plate # 2,			
Pitch Distance	p	69.8500	mm.
Uniform Hole Diameter	d0	25.7000	mm.
Depth of Holes	T0	20.0000	mm.

**Internal Pressure Results, Rect. Vessel # 1, Desc: REAR**  
**ASME Code, Section VIII, Division 1, 2017 App. 13**

**Ligament Efficiency Calculations (Section 13-6, Equations (1)-(6)):**

**Short-side 1 Calculations**

Membrane Ligament Efficiency [Em]:  
 = 0.850

Bending Ligament Efficiency [Eb]:  
 = 0.850

Dist from Neutral axis of c/s to inside surface of the vesssel [Ci]:  
 = t1 - CA / 2  
 = 20.000 - 3.000 / 2  
 = 8.500 mm.

Dist from Neutral axis of c/s to extreme outside surface of the section [Co]:  
 = -( t1 - CA ) / 2  
 = -( 20.000 - 3.000 ) / 2  
 = -8.500 mm.

**Short-side 2 Calculations**

Membrane Ligament Efficiency [Em]:

$$= 0.850$$

Bending Ligament Efficiency [Eb]:

$$= 0.850$$

Dist from Neutral axis of c/s to inside surface of the vessel [Ci]:

$$\begin{aligned} &= t1 - CA / 2 \\ &= 20.000 - 3.000 / 2 \\ &= 8.500 \text{ mm.} \end{aligned}$$

Dist from Neutral axis of c/s to extreme outside surface of the section [Co]:

$$\begin{aligned} &= -( t1 - CA ) / 2 \\ &= -( 20.000 - 3.000 ) / 2 \\ &= -8.500 \text{ mm.} \end{aligned}$$

**Long-side 1 Calculations**

Effective Diameter [De]:

$$\begin{aligned} &= ( d0 * T0 + d1 * T1 + d2 * T2 ) / ( t1 - CA ) \\ &= ( 36.50 * 1.70 + 28.60 * 15.30 + 0.00 * 0.00 ) / \\ &\quad ( 20.00 - 3.00 ) \\ &= 29.390 \text{ mm.} \end{aligned}$$

Membrane Ligament Efficiency [Em]:

$$\begin{aligned} &= Pitch - De / Pitch \\ &= 69.850 - 29.390 / 69.850 \\ &= 0.579 \end{aligned}$$

Dist from Neutral axis of c/s to extreme fibers [Ci & Co]:

Calculation of Xbar:

$$\begin{aligned} &= ( ( b0 * T0 * ( T0/2 + T1 + T2 ) ) + ( b1 * T1 * \\ &\quad ( T1/2 + T2 ) ) + ( b2 * T2 * ( T2/2 ) ) ) / \\ &\quad ( b0 * T0 + b1 * T1 + b2 * T2 ) \\ &= ( ( 1.31 * 1.70 * ( 1.70 / 2 + 15.30 + 0.00 ) ) + ( 1.62 * 15.30 * \\ &\quad ( 15.30 / 2 + 0.00 ) ) + ( 2.75 * 0.00 * ( 0.00 / 2 ) ) ) / \\ &\quad ( 1.31 * 1.70 + 1.62 * 15.30 + 2.75 * 0.00 ) \\ &= 8.351 \text{ mm.} \end{aligned}$$

Dist from Neutral axis of c/s to inside surface of the vessel [Ci]:

$$\begin{aligned} Ci &= Xbar \\ &= 8.351 \text{ mm.} \end{aligned}$$

Dist from Neutral axis of c/s to extreme outside surface of the section [Co]:

$$\begin{aligned} &= -( t - CA - Xbar ) \\ &= -( 20.000 - 3.000 - 8.351 ) \\ &= -8.649 \text{ mm.} \end{aligned}$$

Moment of Inertia (Section 13-6, Equation (5)) [I]:

$$= 0.063 \text{ cm}^4$$

Effective Diameter [De]:

$$\begin{aligned} &= Pitch - ( ( 6 * I ) / ( ( t - CA)^2 * (-Co) ) ) \\ &= 69.85 - ( ( 6 * 0.06 ) / ( (20.00 - 3.00 )^2 * (8.65 ) ) ) \\ &= 31.244 \text{ mm.} \end{aligned}$$

Bending Ligament Efficiency [Eb]:

$$\begin{aligned} &= Pitch - De / Pitch \\ &= 69.850 - 31.244 / 69.850 \\ &= 0.553 \end{aligned}$$

**Long-side 2 Calculations**

Effective Diameter [De]: 25.700 mm.

Membrane Ligament Efficiency [Em]:

$$\begin{aligned} &= Pitch - De / Pitch \\ &= 69.850 - 25.700 / 69.850 \\ &= 0.632 \end{aligned}$$

Bending Ligament Efficiency [Eb]:

As diameter holes are uniform  $E_b = E_m$   
 = 0.632

Dist from Neutral axis of c/s to inside surface of the vessel [Ci]:

$$= t_1 - CA / 2$$

$$= 20.000 - 3.000 / 2$$

$$= 8.500 \text{ mm.}$$

Dist from Neutral axis of c/s to extreme outside surface of the section [Co]:

$$= -( t_1 - CA ) / 2$$

$$= -( 20.000 - 3.000 ) / 2$$

$$= -8.500 \text{ mm.}$$

**Ligament Efficiency Calculations (Section 13-6, Equations (1)-(6)):**

	Em	Eb	Ci	Co
Short-side 1	0.850	0.850	8.500	-8.500
2	0.850	0.850	8.500	-8.500
Long-side 1	0.579	0.553	8.351	-8.649
2	0.632	0.632	8.500	-8.500

**Moment of Inertia of a Strip of the Vessel Wall:**

Thickness  $t_1$ ,  $I_1 = 0.0409 \text{ cm}^{*4}$   
 Thickness  $t_2$ ,  $I_2 = 0.0409 \text{ cm}^{*4}$

**Rectangular Vessel Parameters:**

Alpha =  $H / h = 0.3605$   
 $K = (I_2/I_1) * Alpha = 0.3605$

**Membrane Stress Calculations per Section 13-7**

**Membrane Stresses at Short-side 1**

Membrane Stress at Short-side 1 [Sms]:

$$= P * H / ( 2 * t_1 )$$

$$= 0.0 * 294.00 / ( 2 * 17.000 )$$

$$= 0.01 \text{ N./mm}^2$$

**Membrane Stresses at Short-side 2**

Membrane Stress at Short-side 2 [Sms]:

$$= P * H / ( 2 * t_1 )$$

$$= 0.0 * 294.00 / ( 2 * 17.000 )$$

$$= 0.01 \text{ N./mm}^2$$

**Membrane Stresses at Long-side 1**

Membrane Stress at Long-side 1 at A [Sml]:

$$= p * h / ( 2 * t_2 )$$

$$= 0.0 * 106.00 / ( 2 * 17.000 )$$

$$= 0.00 \text{ N./mm}^2$$

If  $E_m(0.579) < E(0.850)$  and  $E_b(0.553) < E(0.850)$  then  $S_{ml} = S_{ml} / E_m$

$$= 0.00 / 0.58$$

$$= 0.01 \text{ N./mm}^2$$

**Membrane Stresses at Long-side 2**

Membrane Stress at Long-side 2 at A [Sml]:

$$= p * h / ( 2 * t_2 )$$

$$= 0.0 * 106.00 / ( 2 * 17.000 )$$

$$= 0.00 \text{ N./mm}^2$$

If  $E_m(0.632) < E(0.850)$  and  $E_b(0.632) < E(0.850)$  then  $S_{ml} = S_{ml} / E_m$

$$= 0.00 / 0.63$$

$$= 0.00 \text{ N./mm}^2$$

**MEMBRANE STRESSES: Membrane Stress Calculations per Section 13-7,**

**Equations (1) and (2). (N./mm<sup>2</sup>) :**

STRESS LOCATIONS	Actual	Allowable
Short-side 1	0.01	117.22
Short-side 2	0.01	117.22
Short-side Corner	0.01	117.22
Long-side 1 at A	0.01	137.90
Long-side 2 at A	0.00	137.90
Long-side Corner	0.00	117.22

**Bending Stress Calculations per Section 13-7**

**Bending Stresses at Short-side 1**

Bending Stresses at short side 1 at N inner [Sbs\_Ni]:

$$= ( P * c ) / ( 12 * I1 ) * ( ( -1.5 * H^2 ) + ( h^2 * ( ( 1 + alpha^2 * K ) / ( 1 + K ) ) ) )$$

$$= ( 0.0 * 8.50 ) / ( 12 * 0.04 ) * ( ( -1.5 * 106.00^2 ) + ( 294.00^2 * ( ( 1 + 0.36^2 * 0.361 ) / ( 1 + 0.361 ) ) ) )$$

$$= 0.09 \text{ N./mm}^2$$

Bending Stress at short side 1 at N outer [Sbs\_No]:

$$= ( P * c ) / ( 12 * I1 ) * ( ( -1.5 * H^2 ) + ( h^2 * ( ( 1 + alpha^2 * K ) / ( 1 + K ) ) ) )$$

$$= ( 0.0 * -8.50 ) / ( 12 * 0.04 ) * ( ( -1.5 * 106.00^2 ) + ( 294.00^2 * ( ( 1 + 0.36^2 * 0.361 ) / ( 1 + 0.361 ) ) ) )$$

$$= -0.09 \text{ N./mm}^2$$

Bending Stress at short side 1 at Q inner [Sbs\_Qi]:

$$= ( P * h^2 * c ) / ( 12 * I1 ) * ( ( 1 + alpha^2 * K ) / ( 1 + K ) )$$

$$= ( 0.0 * 294.00^2 * 8.500 ) / ( 12 * 0.04 ) * ( ( 1 + 0.36^2 * 0.361 ) / ( 1 + 0.361 ) )$$

$$= 0.12 \text{ N./mm}^2$$

Bending Stress at short side 1 at Q outer [Sbs\_Qo]:

$$= ( P * h^2 * c ) / ( 12 * I1 ) * ( ( 1 + alpha^2 * K ) / ( 1 + K ) )$$

$$= ( 0.0 * 294.00^2 * -8.500 ) / ( 12 * 0.04 ) * ( ( 1 + 0.36^2 * 0.361 ) / ( 1 + 0.361 ) )$$

$$= -0.12 \text{ N./mm}^2$$

**Bending Stresses at Short-side 2**

Bending Stresses at short side 2 at N inner [Sbs\_Ni]:

$$= ( P * c ) / ( 12 * I1 ) * ( ( -1.5 * H^2 ) + ( h^2 * ( ( 1 + alpha^2 * K ) / ( 1 + K ) ) ) )$$

$$= ( 0.0 * 8.50 ) / ( 12 * 0.04 ) * ( ( -1.5 * 106.00^2 ) + ( 294.00^2 * ( ( 1 + 0.36^2 * 0.361 ) / ( 1 + 0.361 ) ) ) )$$

$$= 0.09 \text{ N./mm}^2$$

Bending Stress at short side 2 at N outer [Sbs\_No]:

$$= ( P * c ) / ( 12 * I1 ) * ( ( -1.5 * H^2 ) + ( h^2 * ( ( 1 + alpha^2 * K ) / ( 1 + K ) ) ) )$$

$$= ( 0.0 * -8.50 ) / ( 12 * 0.04 ) * ( ( -1.5 * 106.00^2 ) + ( 294.00^2 * ( ( 1 + 0.36^2 * 0.361 ) / ( 1 + 0.361 ) ) ) )$$

$$= -0.09 \text{ N./mm}^2$$

Bending Stress at short side 2 at Q inner [Sbs\_Qi]:

$$= ( P * h^2 * c ) / ( 12 * I1 ) * ( ( 1 + alpha^2 * K ) / ( 1 + K ) )$$

$$= ( 0.0 * 294.00^2 * 8.500 ) / ( 12 * 0.04 ) * ( ( 1 + 0.36^2 * 0.361 ) / ( 1 + 0.361 ) )$$

$$= 0.12 \text{ N./mm}^2$$

Bending Stress at short side 2 at Q outer [Sbs\_Qo]:

$$= ( P * h^2 * c ) / ( 12 * I1 ) * ( ( 1 + alpha^2 * K ) / ( 1 + K ) )$$

$$= ( 0.0 * 294.00^2 * -8.500 ) / ( 12 * 0.04 ) * ( ( 1 + 0.36^2 * 0.361 ) / ( 1 + 0.361 ) )$$

$$= -0.12 \text{ N./mm}^2$$

**Bending Stress at Long-side 1**

Bending Stress at long side 1 at M inner [Sbl\_Mi]:

$$= ( P * h^2 * c ) / ( 12 * I2 ) * ( -1.5 + ( ( 1 + \alpha^2 * K ) / ( 1 + K ) ) )$$

$$= ( 0.0 * 294.00^2 * 8.351 ) / ( 12 * 0.04 ) * ( -1.5 + ( ( 1 + 0.36^2 * 0.361 ) / ( 1 + 0.361 ) ) )$$

$$= -0.11 \text{ N./mm}^2$$

If  $E_m(0.579) < E(0.850)$  and  $E_b(0.553) < E(0.850)$  then

$$S_{bl\_Mi} = S_{bl\_Mi} / E_m$$

$$= -0.11 / 0.58$$

$$= -0.19 \text{ N./mm}^2$$

Bending Stress at long side 1 at M outer [Sbl\_Mo]:

$$= ( P * h^2 * c ) / ( 12 * I2 ) * ( -1.5 + ( 1 + \alpha^2 * K ) / ( 1 + K ) )$$

$$= ( 0.0 * 294.00^2 * -8.649 ) / ( 12 * 0.04 ) * ( -1.5 + ( 1 + 0.36^2 * 0.361 ) / ( 1 + 0.361 ) )$$

$$= 0.11 \text{ N./mm}^2$$

If  $E_m(0.579) < E(0.850)$  and  $E_b(0.553) < E(0.850)$  then

$$S_{bl\_Mo} = S_{bl\_Mo} / E_m$$

$$= 0.11 / 0.58$$

$$= 0.20 \text{ N./mm}^2$$

Bending Stress at long side 1 at Q inner [Sbl\_Qi]:

$$= ( P * h^2 * c ) / ( 12 * I2 ) * ( ( 1 + \alpha^2 * K ) / ( 1 + K ) )$$

$$= ( 0.0 * 294.00^2 * 8.351 ) / ( 12 * 0.04 ) * ( ( 1 + 0.36^2 * 0.361 ) / ( 1 + 0.361 ) )$$

$$= 0.11 \text{ N./mm}^2$$

Bending Stress at long side 1 at Q outer [Sbl\_Qo]:

$$= ( P * h^2 * c ) / ( 12 * I2 ) * ( ( 1 + \alpha^2 * K ) / ( 1 + K ) )$$

$$= ( 0.0 * 294.00^2 * -8.649 ) / ( 12 * 0.04 ) * ( ( 1 + 0.36^2 * 0.361 ) / ( 1 + 0.361 ) )$$

$$= -0.12 \text{ N./mm}^2$$

**Bending Stress at Long-side 2**

Bending Stress at long side 2 at M inner [Sbl\_Mi]:

$$= ( P * h^2 * c ) / ( 12 * I2 ) * ( -1.5 + ( ( 1 + \alpha^2 * K ) / ( 1 + K ) ) )$$

$$= ( 0.0 * 294.00^2 * 8.500 ) / ( 12 * 0.04 ) * ( -1.5 + ( ( 1 + 0.36^2 * 0.361 ) / ( 1 + 0.361 ) ) )$$

$$= -0.11 \text{ N./mm}^2$$

If  $E_m(0.632) < E(0.850)$  and  $E_b(0.632) < E(0.850)$  then

$$S_{bl\_Mi} = S_{bl\_Mi} / E_m$$

$$= -0.11 / 0.63$$

$$= -0.17 \text{ N./mm}^2$$

Bending Stress at long side 2 at M outer [Sbl\_Mo]:

$$= ( P * h^2 * c ) / ( 12 * I2 ) * ( -1.5 + ( 1 + \alpha^2 * K ) / ( 1 + K ) )$$

$$= ( 0.0 * 294.00^2 * -8.500 ) / ( 12 * 0.04 ) * ( -1.5 + ( 1 + 0.36^2 * 0.361 ) / ( 1 + 0.361 ) )$$

$$= 0.11 \text{ N./mm}^2$$

If  $E_m(0.632) < E(0.850)$  and  $E_b(0.632) < E(0.850)$  then

$$S_{bl\_Mo} = S_{bl\_Mo} / E_m$$

$$= 0.11 / 0.63$$

$$= 0.17 \text{ N./mm}^2$$

Bending Stress at long side 2 at Q inner [Sbl\_Qi]:

$$= ( P * h^2 * c ) / ( 12 * I2 ) * ( ( 1 + \alpha^2 * K ) / ( 1 + K ) )$$

$$= ( 0.0 * 294.00^2 * 8.500 ) / ( 12 * 0.04 ) * ( ( 1 + 0.36^2 * 0.361 ) / ( 1 + 0.361 ) )$$

$$= 0.12 \text{ N./mm}^2$$

Bending Stress at long side 2 at Q outer [Sbl\_Qo]:

$$= ( P * h^2 * c ) / ( 12 * I2 ) * ( ( 1 + \alpha^2 * K ) / ( 1 + K ) )$$

$$= ( 0.0 * 294.00^2 * -8.500 ) / ( 12 * 0.04 ) * ( ( 1 + 0.36^2 * 0.361 ) / ( 1 + 0.361 ) )$$

$$\begin{aligned} & / ( 1 + 0.361 ) ) \\ & = -0.12 \text{ N./mm}^2 \end{aligned}$$

**BENDING STRESSES: Bending Stress Calculations per Section 13-7, Equations (3-6). (N./mm<sup>2</sup>) :**

STRESS LOCATIONS	Inner	Outer	Allowable
Short-side 1 at N	0.09	-0.09	175.82
at Q	0.12	-0.12	175.82
Short-side 2 at N	0.09	-0.09	175.82
at Q	0.12	-0.12	175.82
Long-side 1 at M	-0.19	0.20	206.85
at Q	0.11	-0.12	175.82
Long-side 2 at M	-0.17	0.17	206.85
at Q	0.12	-0.12	175.82

**Total Stress Calculations per Section 13-7**

**Total Stresses at Short-side 1**

Total Stress at short side 1 at N inner [STS\_Ni]:  
 = S<sub>ms</sub> + S<sub>bs\_Ni</sub>  
 = 0.01 + 0.09  
 = 0.09 N./mm<sup>2</sup>

Total Stress at short side 1 at N outer [STS\_No]:  
 = S<sub>ms</sub> + S<sub>bs\_No</sub>  
 = 0.01 + -0.09  
 = -0.08 N./mm<sup>2</sup>

Total Stress at short side 1 at Q inner [STS\_Qi]:  
 = S<sub>ms</sub> + S<sub>bs\_Qi</sub>  
 = 0.01 + 0.12  
 = 0.12 N./mm<sup>2</sup>

Total Stress at short side 1 at Q outer [STS\_Qo]:  
 = S<sub>ms</sub> + S<sub>b\_Qo</sub>  
 = 0.01 + -0.12  
 = -0.11 N./mm<sup>2</sup>

**Total Stresses at Short-side 2**

Total Stress at short side 2 at N inner [STS\_Ni]:  
 = S<sub>ms</sub> + S<sub>bs\_Ni</sub>  
 = 0.01 + 0.09  
 = 0.09 N./mm<sup>2</sup>

Total Stress at short side 2 at N outer [STS\_No]:  
 = S<sub>ms</sub> + S<sub>bs\_No</sub>  
 = 0.01 + -0.09  
 = -0.08 N./mm<sup>2</sup>

Total Stress at short side 2 at Q inner [STS\_Qi]:  
 = S<sub>ms</sub> + S<sub>bs\_Qi</sub>  
 = 0.01 + 0.12  
 = 0.12 N./mm<sup>2</sup>

Total Stress at short side 2 at Q outer [STS\_Qo]:  
 = S<sub>ms</sub> + S<sub>b\_Qo</sub>  
 = 0.01 + -0.12  
 = -0.11 N./mm<sup>2</sup>

**Total Stresses at Long-side 1**

Total Stress at long side 1 at M inner [STL\_Mi]:  
 = S<sub>m1</sub> + S<sub>b1\_Mi</sub>  
 = 0.01 + -0.19  
 = -0.19 N./mm<sup>2</sup>

Total Stress at long side 1 at M outer [STL\_Mo]:

= Sml + Sb\_Mo  
 = 0.01 + 0.20  
 = 0.21 N./mm<sup>2</sup>

Total Stress at long side 1 at Q inner [STL\_Qi]:  
 = Sml + Sb1\_Qi  
 = 0.01 + 0.11  
 = 0.12 N./mm<sup>2</sup>

Total Stress at long side 1 at Q outer [STL\_Qo]:  
 = Sml + Sb\_Qo  
 = 0.01 + -0.12  
 = -0.11 N./mm<sup>2</sup>

**Total Stresses at Long-side 2**

Total Stress at long side 2 at M inner [STL\_Mi]:  
 = Sml + Sb1\_Mi  
 = 0.00 + -0.17  
 = -0.17 N./mm<sup>2</sup>

Total Stress at long side 2 at M outer [STL\_Mo]:  
 = Sml + Sb\_Mo  
 = 0.00 + 0.17  
 = 0.18 N./mm<sup>2</sup>

Total Stress at long side 2 at Q inner [STL\_Qi]:  
 = Sml + Sb1\_Qi  
 = 0.00 + 0.12  
 = 0.12 N./mm<sup>2</sup>

Total Stress at long side 2 at Q outer [STL\_Qo]:  
 = Sml + Sb\_Qo  
 = 0.00 + -0.12  
 = -0.11 N./mm<sup>2</sup>

**TOTAL STRESSES: Total Stress Calculations per Section 13-7, Equations (7-10). (N./mm<sup>2</sup>) :**

STRESS LOCATIONS	Inner	Outer	Allowable
Short-side 1 at N	0.09	-0.08	175.82
at Q	0.12	-0.11	175.82
Short-side 2 at N	0.09	-0.08	175.82
at Q	0.12	-0.11	175.82
Long-side 1 at M	-0.19	0.21	206.85
at Q	0.12	-0.11	175.82
Long-side 2 at M	-0.17	0.18	206.85
at Q	0.12	-0.11	175.82

**END PLATE STRESSES (N./mm<sup>2</sup>) :**

	Actual	Allowable
End Plate	0.02	137.90

**SUMMARY OF RESULTS (INTERNAL PRESSURE):**

**MEMBRANE STRESS SUMMARY,**

High Stress (Highest % of Allowable)	0.01	N./mm <sup>2</sup>
High Stress Percentage	0.01	%
M.A.W.P. for Membrane Stresses	135.55	bars

**BENDING STRESS SUMMARY,**

High Stress (Highest % of Allowable)	0.20	N./mm <sup>2</sup>
High Stress Percentage	0.10	%
M.A.W.P. for Bending Stresses	10.28	bars

**TOTAL STRESS SUMMARY,**

High Stress (Highest % of Allowable)	0.21	N./mm <sup>2</sup>
High Stress Percentage	0.10	%
M.A.W.P. for Total Stresses	10.02	bars

**Internal Pressure Results, Rect. Vessel # 1, Desc: REAR**  
**ASME Code, Section VIII, Division 1, 2017 App. 13**

**Ligament Efficiency Calculations (Section 13-6, Equations (1)-(6)):**

**Short-side 1 Calculations**

Membrane Ligament Efficiency [Em]:  
 = 0.850

Bending Ligament Efficiency [Eb]:  
 = 0.850

Dist from Neutral axis of c/s to inside surface of the vessel [Ci]:  
 =  $t_1 - CA / 2$   
 =  $20.000 - 3.000 / 2$   
 = 8.500 mm.

Dist from Neutral axis of c/s to extreme outside surface of the section [Co]:  
 =  $-(t_1 - CA) / 2$   
 =  $-(20.000 - 3.000) / 2$   
 = -8.500 mm.

**Short-side 2 Calculations**

Membrane Ligament Efficiency [Em]:  
 = 0.850

Bending Ligament Efficiency [Eb]:  
 = 0.850

Dist from Neutral axis of c/s to inside surface of the vessel [Ci]:  
 =  $t_1 - CA / 2$   
 =  $20.000 - 3.000 / 2$   
 = 8.500 mm.

Dist from Neutral axis of c/s to extreme outside surface of the section [Co]:  
 =  $-(t_1 - CA) / 2$   
 =  $-(20.000 - 3.000) / 2$   
 = -8.500 mm.

**Long-side 1 Calculations**

Effective Diameter [De]:  
 =  $(d_0 * T_0 + d_1 * T_1 + d_2 * T_2) / (t_1 - CA)$   
 =  $(36.50 * 1.70 + 28.60 * 12.30 + 0.00 * 0.00) / (20.00 - 3.00)$   
 = 24.343 mm.

Membrane Ligament Efficiency [Em]:  
 =  $Pitch - De / Pitch$   
 =  $69.850 - 24.343 / 69.850$   
 = 0.651

Dist from Neutral axis of c/s to extreme fibers [Ci & Co]:

**Calculation of Xbar:**

$$= ((b_0 * T_0 * (T_0/2 + T_1 + T_2)) + (b_1 * T_1 * (T_1/2 + T_2)) + (b_2 * T_2 * (T_2/2))) / (b_0 * T_0 + b_1 * T_1 + b_2 * T_2)$$

$$= ((1.31 * 1.70 * (1.70/2 + 12.30 + 0.00)) + (1.62 * 12.30 * (12.30/2 + 0.00)) + (2.75 * 0.00 * (0.00/2))) / (1.31 * 1.70 + 1.62 * 12.30 + 2.75 * 0.00)$$

$$= 6.854 \text{ mm.}$$

Dist from Neutral axis of c/s to inside surface of the vessel [Ci]:  
 $Ci = Xbar$   
 = 6.854 mm.

FileName : F.V.REAR-rev.01

Rectves Analysis : REAR

Item: 1 1:29p Jul 20,2024

Dist from Neutral axis of c/s to extreme outside surface of the section [Co]:

$$= -(t - CA - Xbar)$$

$$= -(20.000 - 3.000 - 6.854)$$

$$= -10.146 \text{ mm.}$$

Moment of Inertia (Section 13-6, Equation (5)) [I]:

$$= 0.035 \text{ cm}^4$$

Effective Diameter [De]:

$$= Pitch - ((6 * I) / ((t - CA)^2 * (-Co)))$$

$$= 69.85 - ((6 * 0.04) / ((20.00 - 3.00)^2 * (10.15)))$$

$$= 51.620 \text{ mm.}$$

Bending Ligament Efficiency [Eb]:

$$= Pitch - De / Pitch$$

$$= 69.850 - 51.620 / 69.850$$

$$= 0.261$$

**Long-side 2 Calculations**

Effective Diameter [De]: 25.700 mm.

Membrane Ligament Efficiency [Em]:

$$= Pitch - De / Pitch$$

$$= 69.850 - 25.700 / 69.850$$

$$= 0.632$$

Bending Ligament Efficiency [Eb]:

As diameter holes are uniform  $E_b = E_m$

$$= 0.632$$

Dist from Neutral axis of c/s to inside surface of the vessel [Ci]:

$$= t1 - CA / 2$$

$$= 20.000 - 3.000 / 2$$

$$= 8.500 \text{ mm.}$$

Dist from Neutral axis of c/s to extreme outside surface of the section [Co]:

$$= -(t1 - CA) / 2$$

$$= -(20.000 - 3.000) / 2$$

$$= -8.500 \text{ mm.}$$

**Ligament Efficiency Calculations (Section 13-6, Equations (1)-(6)):**

	Em	Eb	Ci	Co
Short-side 1	0.850	0.850	8.500	-8.500
2	0.850	0.850	8.500	-8.500
Long-side 1	0.651	0.261	6.854	-10.146
2	0.632	0.632	8.500	-8.500

**Moment of Inertia of a Strip of the Vessel Wall:**

Thickness t1, I1 = 0.0409 cm<sup>4</sup>  
 Thickness t2, I2 = 0.0409 cm<sup>4</sup>

**Rectangular Vessel Parameters:**

Alpha = H / h = 0.3605  
 K = (I2/I1)\*Alpha = 0.3605

**Membrane Stress Calculations per Section 13-7**

**Membrane Stresses at Short-side 1**

Membrane Stress at Short-side 1 [Sms]:

$$= P * H / (2 * t1)$$

$$= 1.0 * 294.00 / (2 * 17.000)$$

$$= 0.86 \text{ N./mm}^2$$

**Membrane Stresses at Short-side 2**

Membrane Stress at Short-side 2 [Sms]:

FileName : F.V.REAR-rev.01 -----

Rectves Analysis : REAR Item: 1 1:29p Jul 20,2024

$$\begin{aligned}
 &= P * H / ( 2 * t1 ) \\
 &= 1.0 * 294.00 / ( 2 * 17.000 ) \\
 &= 0.86 \text{ N./mm}^2
 \end{aligned}$$

**Membrane Stresses at Long-side 1**

Membrane Stress at Long-side 1 at A [Sml]:

$$\begin{aligned}
 &= p * h / ( 2 * t2 ) \\
 &= 1.0 * 106.00 / ( 2 * 17.000 ) \\
 &= 0.31 \text{ N./mm}^2
 \end{aligned}$$

If  $E_m(0.651) < E(0.850)$  and  $E_b(0.261) < E(0.850)$  then  $Sml = Sml / Em$

$$\begin{aligned}
 &= 0.31 / 0.65 \\
 &= 0.48 \text{ N./mm}^2
 \end{aligned}$$

**Membrane Stresses at Long-side 2**

Membrane Stress at Long-side 2 at A [Sml]:

$$\begin{aligned}
 &= p * h / ( 2 * t2 ) \\
 &= 1.0 * 106.00 / ( 2 * 17.000 ) \\
 &= 0.31 \text{ N./mm}^2
 \end{aligned}$$

If  $E_m(0.632) < E(0.850)$  and  $E_b(0.632) < E(0.850)$  then  $Sml = Sml / Em$

$$\begin{aligned}
 &= 0.31 / 0.63 \\
 &= 0.49 \text{ N./mm}^2
 \end{aligned}$$

**MEMBRANE STRESSES: Membrane Stress Calculations per Section 13-7, Equations (1) and (2). (N./mm<sup>2</sup>) :**

STRESS LOCATIONS	Actual	Allowable
Short-side 1	0.86	117.22
Short-side 2	0.86	117.22
Short-side Corner	0.86	117.22
Long-side 1 at A	0.48	137.90
Long-side 2 at A	0.49	137.90
Long-side Corner	0.31	117.22

**Bending Stress Calculations per Section 13-7**

**Bending Stresses at Short-side 1**

Bending Stresses at short side 1 at N inner [Sbs\_Ni]:

$$\begin{aligned}
 &= ( P * c ) / ( 12 * I1 ) * ( ( -1.5 * H^2 ) + ( h^2 * ( ( 1 + \alpha^2 * K ) / ( 1 + K ) ) ) ) \\
 &= ( 1.0 * 8.50 ) / ( 12 * 0.04 ) * ( ( -1.5 * 106.00^2 ) + ( 294.00^2 * ( ( 1 + 0.36^2 * 0.361 ) / ( 1 + 0.361 ) ) ) ) \\
 &= 8.59 \text{ N./mm}^2
 \end{aligned}$$

Bending Stress at short side 1 at N outer [Sbs\_No]:

$$\begin{aligned}
 &= ( P * c ) / ( 12 * I1 ) * ( ( -1.5 * H^2 ) + ( h^2 * ( ( 1 + \alpha^2 * K ) / ( 1 + K ) ) ) ) \\
 &= ( 1.0 * -8.50 ) / ( 12 * 0.04 ) * ( ( -1.5 * 106.00^2 ) + ( 294.00^2 * ( ( 1 + 0.36^2 * 0.361 ) / ( 1 + 0.361 ) ) ) ) \\
 &= -8.59 \text{ N./mm}^2
 \end{aligned}$$

Bending Stress at short side 1 at Q inner [Sbs\_Qi]:

$$\begin{aligned}
 &= ( P * h^2 * c ) / ( 12 * I1 ) * ( ( 1 + \alpha^2 * K ) / ( 1 + K ) ) \\
 &= ( 1.0 * 294.00^2 * 8.500 ) / ( 12 * 0.04 ) * ( ( 1 + 0.36^2 * 0.361 ) / ( 1 + 0.361 ) ) \\
 &= 11.51 \text{ N./mm}^2
 \end{aligned}$$

Bending Stress at short side 1 at Q outer [Sbs\_Qo]:

$$\begin{aligned}
 &= ( P * h^2 * c ) / ( 12 * I1 ) * ( ( 1 + \alpha^2 * K ) / ( 1 + K ) ) \\
 &= ( 1.0 * 294.00^2 * -8.500 ) / ( 12 * 0.04 ) * ( ( 1 + 0.36^2 * 0.361 ) / ( 1 + 0.361 ) ) \\
 &= -11.51 \text{ N./mm}^2
 \end{aligned}$$

**Bending Stresses at Short-side 2**

Bending Stresses at short side 2 at N inner [Sbs\_Ni]:

$$\begin{aligned}
 &= ( P * c ) / ( 12 * I1 ) * ( ( -1.5 * H^2 ) +
 \end{aligned}$$

FileName : F.V.REAR-rev.01

Rectves Analysis : REAR

Item: 1 1:29p Jul 20,2024

$$\begin{aligned}
 & ( h^2 * ( ( 1 + \alpha^2 * K ) / ( 1 + K ) ) ) \\
 = & ( 1.0 * 8.50 ) / ( 12 * 0.04 ) * ( ( -1.5 * 106.00^2 ) + \\
 & ( 294.00^2 * ( ( 1 + 0.36^2 * 0.361 ) / ( 1 + 0.361 ) ) ) ) \\
 = & 8.59 \text{ N./mm}^2
 \end{aligned}$$

Bending Stress at short side 2 at N outer [Sbs\_No]:

$$\begin{aligned}
 = & ( P * c ) / ( 12 * I1 ) * ( ( -1.5 * H^2 ) + \\
 & ( h^2 * ( ( 1 + \alpha^2 * K ) / ( 1 + K ) ) ) ) \\
 = & ( 1.0 * -8.50 ) / ( 12 * 0.04 ) * ( ( -1.5 * 106.00^2 ) + \\
 & ( 294.00^2 * ( ( 1 + 0.36^2 * 0.361 ) / ( 1 + 0.361 ) ) ) ) \\
 = & -8.59 \text{ N./mm}^2
 \end{aligned}$$

Bending Stress at short side 2 at Q inner [Sbs\_Qi]:

$$\begin{aligned}
 = & ( P * h^2 * c ) / ( 12 * I1 ) * ( ( 1 + \alpha^2 * K ) / ( 1 + K ) ) \\
 = & ( 1.0 * 294.00^2 * 8.500 ) / ( 12 * 0.04 ) * ( ( 1 + 0.36^2 * 0.361 ) / \\
 & ( 1 + 0.361 ) ) \\
 = & 11.51 \text{ N./mm}^2
 \end{aligned}$$

Bending Stress at short side 2 at Q outer [Sbs\_Qo]:

$$\begin{aligned}
 = & ( P * h^2 * c ) / ( 12 * I1 ) * ( ( 1 + \alpha^2 * K ) / ( 1 + K ) ) \\
 = & ( 1.0 * 294.00^2 * -8.500 ) / ( 12 * 0.04 ) * ( ( 1 + 0.36^2 * 0.361 ) / \\
 & ( 1 + 0.361 ) ) \\
 = & -11.51 \text{ N./mm}^2
 \end{aligned}$$

**Bending Stress at Long-side 1**

Bending Stress at long side 1 at M inner [Sbl\_Mi]:

$$\begin{aligned}
 = & ( P * h^2 * c ) / ( 12 * I2 ) * ( -1.5 + ( ( 1 + \alpha^2 * K ) / \\
 & ( 1 + K ) ) ) \\
 = & ( 1.0 * 294.00^2 * 6.854 ) / ( 12 * 0.04 ) * ( -1.5 + ( ( 1 + 0.36^2 * \\
 & 0.361 ) / ( 1 + 0.361 ) ) ) \\
 = & -8.81 \text{ N./mm}^2
 \end{aligned}$$

If  $E_m(0.651) < E(0.850)$  and  $E_b(0.261) < E(0.850)$  then

$$\begin{aligned}
 Sbl\_Mi &= Sbl\_Mi / E_m \\
 &= -8.81 / 0.65 \\
 &= -33.75 \text{ N./mm}^2
 \end{aligned}$$

Bending Stress at long side 1 at M outer [Sbl\_Mo]:

$$\begin{aligned}
 = & ( P * h^2 * c ) / ( 12 * I2 ) * ( -1.5 + ( 1 + \alpha^2 * K ) / \\
 & ( 1 + K ) ) \\
 = & ( 1.0 * 294.00^2 * -10.146 ) / ( 12 * 0.04 ) * ( -1.5 + ( 1 + 0.36^2 * \\
 & 0.361 ) / ( 1 + 0.361 ) ) \\
 = & 13.04 \text{ N./mm}^2
 \end{aligned}$$

If  $E_m(0.651) < E(0.850)$  and  $E_b(0.261) < E(0.850)$  then

$$\begin{aligned}
 Sbl\_Mo &= Sbl\_Mo / E_m \\
 &= 13.04 / 0.65 \\
 &= 49.97 \text{ N./mm}^2
 \end{aligned}$$

Bending Stress at long side 1 at Q inner [Sbl\_Qi]:

$$\begin{aligned}
 = & ( P * h^2 * c ) / ( 12 * I2 ) * ( ( 1 + \alpha^2 * K ) / ( 1 + K ) ) \\
 = & ( 1.0 * 294.00^2 * 6.854 ) / ( 12 * 0.04 ) * ( ( 1 + 0.36^2 * 0.361 ) / \\
 & ( 1 + 0.361 ) ) \\
 = & 9.28 \text{ N./mm}^2
 \end{aligned}$$

Bending Stress at long side 1 at Q outer [Sbl\_Qo]:

$$\begin{aligned}
 = & ( P * h^2 * c ) / ( 12 * I2 ) * ( ( 1 + \alpha^2 * K ) / ( 1 + K ) ) \\
 = & ( 1.0 * 294.00^2 * -10.146 ) / ( 12 * 0.04 ) * ( ( 1 + 0.36^2 * 0.361 ) \\
 & / ( 1 + 0.361 ) ) \\
 = & -13.74 \text{ N./mm}^2
 \end{aligned}$$

**Bending Stress at Long-side 2**

Bending Stress at long side 2 at M inner [Sbl\_Mi]:

$$\begin{aligned}
 = & ( P * h^2 * c ) / ( 12 * I2 ) * ( -1.5 + ( ( 1 + \alpha^2 * K ) / \\
 & ( 1 + K ) ) ) \\
 = & ( 1.0 * 294.00^2 * 8.500 ) / ( 12 * 0.04 ) * ( -1.5 + ( ( 1 + 0.36^2 * \\
 & 0.361 ) / ( 1 + 0.361 ) ) ) \\
 = & -10.93 \text{ N./mm}^2
 \end{aligned}$$

If  $E_m(0.632) < E(0.850)$  and  $E_b(0.632) < E(0.850)$  then

$$\begin{aligned} S_{bl\_Mi} &= S_{bl\_Mi} / E_m \\ &= -10.93 / 0.63 \\ &= -17.29 \text{ N./mm}^2 \end{aligned}$$

Bending Stress at long side 2 at M outer [Sbl\_Mo]:

$$\begin{aligned} &= ( P * h^2 * c ) / ( 12 * I_2 ) * ( -1.5 + ( 1 + \alpha^2 * K ) / ( 1 + K ) ) \\ &= ( 1.0 * 294.00^2 * -8.500 ) / ( 12 * 0.04 ) * ( -1.5 + ( 1 + 0.36^2 * 0.361 ) / ( 1 + 0.361 ) ) \\ &= 10.93 \text{ N./mm}^2 \end{aligned}$$

If  $E_m(0.632) < E(0.850)$  and  $E_b(0.632) < E(0.850)$  then

$$\begin{aligned} S_{bl\_Mo} &= S_{bl\_Mo} / E_m \\ &= 10.93 / 0.63 \\ &= 17.29 \text{ N./mm}^2 \end{aligned}$$

Bending Stress at long side 2 at Q inner [Sbl\_Qi]:

$$\begin{aligned} &= ( P * h^2 * c ) / ( 12 * I_2 ) * ( ( 1 + \alpha^2 * K ) / ( 1 + K ) ) \\ &= ( 1.0 * 294.00^2 * 8.500 ) / ( 12 * 0.04 ) * ( ( 1 + 0.36^2 * 0.361 ) / ( 1 + 0.361 ) ) \\ &= 11.51 \text{ N./mm}^2 \end{aligned}$$

Bending Stress at long side 2 at Q outer [Sbl\_Qo]:

$$\begin{aligned} &= ( P * h^2 * c ) / ( 12 * I_2 ) * ( ( 1 + \alpha^2 * K ) / ( 1 + K ) ) \\ &= ( 1.0 * 294.00^2 * -8.500 ) / ( 12 * 0.04 ) * ( ( 1 + 0.36^2 * 0.361 ) / ( 1 + 0.361 ) ) \\ &= -11.51 \text{ N./mm}^2 \end{aligned}$$

**BENDING STRESSES: Bending Stress Calculations per Section 13-7, Equations (3-6). (N./mm<sup>2</sup>) :**

STRESS LOCATIONS	Inner	Outer	Allowable
Short-side 1 at N	8.59	-8.59	175.82
at Q	11.51	-11.51	175.82
Short-side 2 at N	8.59	-8.59	175.82
at Q	11.51	-11.51	175.82
Long-side 1 at M	-33.75	49.97	206.85
at Q	9.28	-13.74	175.82
Long-side 2 at M	-17.29	17.29	206.85
at Q	11.51	-11.51	175.82

**Total Stress Calculations per Section 13-7**

**Total Stresses at Short-side 1**

Total Stress at short side 1 at N inner [STS\_Ni]:

$$\begin{aligned} &= S_{ms} + S_{bs\_Ni} \\ &= 0.86 + 8.59 \\ &= 9.46 \text{ N./mm}^2 \end{aligned}$$

Total Stress at short side 1 at N outer [STS\_No]:

$$\begin{aligned} &= S_{ms} + S_{bs\_No} \\ &= 0.86 + -8.59 \\ &= -7.73 \text{ N./mm}^2 \end{aligned}$$

Total Stress at short side 1 at Q inner [STS\_Qi]:

$$\begin{aligned} &= S_{ms} + S_{bs\_Qi} \\ &= 0.86 + 11.51 \\ &= 12.37 \text{ N./mm}^2 \end{aligned}$$

Total Stress at short side 1 at Q outer [STS\_Qo]:

$$\begin{aligned} &= S_{ms} + S_{bs\_Qo} \\ &= 0.86 + -11.51 \\ &= -10.64 \text{ N./mm}^2 \end{aligned}$$

**Total Stresses at Short-side 2**

Total Stress at short side 2 at N inner [STS\_Ni]:



PV Elite 2019 SP1 Licensee: SL Client

FileName : F.V.REAR-rev.01

Rectves Analysis : REAR

Item: 1 1:29p Jul 20,2024

	at Q		12.37	-10.64	175.82
Long-side	1 at M		-33.28	50.45	206.85
	at Q		9.76	-13.26	175.82
Long-side	2 at M		-16.79	17.78	206.85
	at Q		12.00	-11.01	175.82

**END PLATE STRESSES (N./mm<sup>2</sup>) :**

End Plate	Actual	Allowable
	1.94	137.90

**PLATE STABILITY CALCULATIONS PER SECTION 13-14(b) (N./mm<sup>2</sup>) :**

Plate Buckling Coefficients (Fig. 13-14(a)):

KA	=	5.65
KB	=	13.15

**Stress Calculations per Section 13-15****Stresses at Short side plates**

Membrane Stress at Short-side at A [SmsA]:

$$= Pe * h * H / ( 2 * ( t1 * H + t2 * h ) )$$

$$= 1.00 * 294.00 * 106.00 / ( 2 * ( 17.00 * 106.00 + 10.75 * 294.00 ) )$$

$$= 0.31 \text{ N./mm}^2$$

Membrane Stress at Short-side at B [SmsB]:

$$= Pe * h / ( 2 * t1 )$$

$$= 1.00 * 294.00 / ( 2 * 17.00 )$$

$$= 0.86 \text{ N./mm}^2$$

Buckling Stress at Short-side at A [ScrsA]:

$$= ( Pi^2 * E2 / ( 12 * ( 1 - \nu^2 ) ) ) * ( t1 / H )^2 * KA$$

$$= ( 3.14^2 * 196921.88 / ( 12 * ( 1 - 0.3^2 ) ) ) * ( 17.00 / 106.00 )^2 * 5.65$$

$$= 25843.00 \text{ N./mm}^2$$

Buckling Stress at Short-side at B [ScrsB]:

$$= Pi^2 * E2 / ( 12 * ( 1 - \nu^2 ) ) * ( t1 / Lv )^2 * KB$$

$$= 3.14^2 * 196921.88 / ( 12 * ( 1 - 0.3^2 ) ) * ( 17.00 / 2510.00 )^2 * 13.15$$

$$= 107.36 \text{ N./mm}^2$$

**Stresses at Long side plates**

Membrane Stress at Long-side at A [SmlA]:

$$= Pe * h * H / ( 2 * ( t1 * H + t2 * H ) )$$

$$= 1.00 * 294.00 * 106.00 / ( 2 * ( 17.00 * 106.00 + 10.75 * 106.00 ) )$$

$$= 0.31 \text{ N./mm}^2$$

Membrane Stress at Long-side at B [SmIB]:

$$= Pe * h / ( 2 * t2 )$$

$$= 1.00 * 294.00 / ( 2 * 10.75 )$$

$$= 0.49 \text{ N./mm}^2$$

Buckling Stress at Long-side at A [ScrlA]:

$$= Pi^2 * E2 / ( 12 * ( 1 - \nu^2 ) ) * ( t2 / H )^2 * KA$$

$$= 3.14^2 * 196921.88 / ( 12 * ( 1 - 0.3^2 ) ) * ( 10.75 / 106.00 )^2 * 5.65$$

$$= 3359.39 \text{ N./mm}^2$$

**ScrlA( 3359.386 ) > 0.5 \* Sy ( 235.976 )**

$$= Sy - ( Sy^2 / ( 4 * ScrlA ) )$$

$$= 235.98 - ( 235.98^2 / ( 4 * 3359.39 ) )$$

$$= 231.83 \text{ N./mm}^2$$

Buckling Stress at Long-side at B [ScrlB]:

$$= Pi^2 * E2 / ( 12 * ( 1 - \nu^2 ) ) * ( t2 / Lv )^2 * KB$$

$$= 3.14^2 * 196921.88 / ( 12 * ( 1 - 0.3^2 ) ) * ( 17.00 / 2510.00 )^2 * 13.15$$

$$= 107.36 \text{ N./mm}^2$$

**Stresses at End plates**

Membrane Stress at End plate at A [SmeA]:

FileName : F.V.REAR-rev.01 -----

Rectves Analysis : REAR Item: 1 1:29p Jul 20,2024

$$= Pe * H * Lv / ( 2 * ( t2 * Lv + t5 * H ) )$$

$$= 1.00 * 106.00 * 2510.00 / ( 2 * ( 10.75 * 2510.00 + 17.00 * 106.00 ) )$$

$$= 0.46 \text{ N./mm}^2$$

Membrane Stress at End plate at B [SmeB]:

$$= Pe * h * Lv / ( 2 * ( t1 * Lv + t5 * h ) )$$

$$= 1.00 * 294.00 * 2510.00 / ( 2 * ( 17.00 * 2510.00 + 17.00 * 294.00 ) )$$

$$= 0.77 \text{ N./mm}^2$$

Buckling Stress at End plate at A [ScreA]:

$$= Pi^2 * E2 / ( 12 * ( 1 - \nu^2 ) * ( t5 / H )^2 * KA$$

$$= 3.14^2 * 196921.88 / ( 12 * ( 1 - 0.3^2 ) * ( 17.00 / 106.00 )^2 * 5.65$$

$$= 25843.00 \text{ N./mm}^2$$

ScreA( 25843.000 ) > 0.5 \* Sy ( 235.976 )

$$= Sy - ( Sy^2 / ( 4 * ScreA ) )$$

$$= 235.98 - ( 235.98^2 / ( 4 * 25843.00 ) )$$

$$= 235.44 \text{ N./mm}^2$$

Buckling Stress at End plate at B [ScreB]:

$$= Pi^2 * E2 / ( 12 * ( 1 - \nu^2 ) * ( t5 / Lv )^2 * KB$$

$$= 3.14^2 * 196921.88 / ( 12 * ( 1 - 0.3^2 ) * ( 17.00 / 294.00 )^2 * 13.15$$

$$= 7825.08 \text{ N./mm}^2$$

ScreB( 7825.080 ) > 0.5 \* Sy ( 235.976 )

$$= Sy - ( Sy^2 / ( 4 * ScreB ) )$$

$$= 235.98 - ( 235.98^2 / ( 4 * 7825.08 ) )$$

$$= 234.20 \text{ N./mm}^2$$

**SUMMARY OF STRESSES PER SECTION 13-14**

Plate(s)	SMA	SMB	SCRA	SCRB	EQN(1)	P/F
Short-sides	0.31	0.86	235.44	107.36	0.019	PASS
Long-sides	0.31	0.49	231.83	107.36	0.012	PASS
End Plates	0.46	0.77	235.44	234.20	0.011	PASS

**CROSS-SECTION STABILITY CALCULATIONS PER SECTION 13-14(c)**

Dist from Outside Surface of Long-side Plate to Vessel Centroid [Yc]:

$$= 70.00 \text{ mm.}$$

Dist from Geometric Center of End Plate to Vessel Centroid [Ybar]:

$$= 0.00 \text{ mm.}$$

Moment of Inertia of Cross Section about Axis Parallel to Long-side and Passing through Vessel Centroid [Ie]:

$$= 4582.27 \text{ cm}^4$$

Least Radius of Gyration of Cross Section [RG]:

$$= \text{Min}( 0.289 * \text{Sqrt}[ Ho^2 + H^2 ] , 0.289 * \text{Sqrt}[ ho^2 + h^2 ] )$$

$$= \text{Min}( 0.289 * \text{Sqrt}[ 140.00^2 + 106.00^2 ] , 0.289 * \text{Sqrt}[ 328.00^2 + 294.00^2 ] )$$

$$= \text{Min}( 50.75 , 127.30 )$$

$$= 50.75 \text{ mm.}$$

Bending Moment of Cross Section (Equation 19) [M]:

$$= Pe * Ho * ho * YBar$$

$$= 1.00 * 328.00 * 140.00 * 0.00$$

$$= 0.00 \text{ Kg-m.}$$

Axial Stress (Eqn 15) [Sa]:

$$= Pe * ho * Ho / ( 2 * ( t1 * Ho + t2 * ho ) )$$

$$= 1.00 * 328.00 * 140.00 / ( 2 * ( 17.00 * 328.00 + 17.00 * 140.00 ) )$$

$$= 0.29 \text{ N./mm}^2$$

Bending Stress (Eqn 18) [Sb]:

$$= ( M * c ) / Ie$$

$$= ( 0.00 * 70.00 ) / 2796.28$$

$$= 0.00 \text{ N./mm}^2$$

Axial Allowed Compressive Stress (Eqn 16A) [Fa]:

FileName : F.V.REAR-rev.01

Rectves Analysis : REAR

Item: 1 1:29p Jul 20,2024

$$= [ 1 - (( 2 * L1 * R1 / ( 2 * Cc^2)))] * Sy / (( 5 / 3 ) + ( 3 * ( 2 * L1 / R1 ) / ( 8 * Cc ) ) - (( 2 * L1 / R1 )^3 / ( 8 * Cc^3)))$$

$$= [ 1 - (( 2 * 2510.00 * 50.75 / ( 2 * 128.34^2)))] * 235.98 / (( 5 / 3 ) + ( 3 * ( 2 * 2510.00 / 50.75 ) / ( 8 * 128.34 ) ) - (( 2 * 2510.00 / 50.75 )^3 / ( 8 * 128.34^3)))$$

$$= 87.38 \text{ N./mm}^2$$

Euler Stress Divided by Factor of Safety (Eqn 20) [Fpe]:

$$= 12 * \pi^2 * E / ( 23 * ( 2 * L1 / R1 )^2)$$

$$= 12 * 3.14^2 * 196921.88 / ( 23 * ( 2 * 2510.00 / 50.75 )^2)$$

$$= 103.63 \text{ N./mm}^2$$

Column Stability Check per Equation 14

$$= Sa / Fa + Sb / [( 1 - Sa / Fpe ) * S ]$$

$$= 0.29 / 87.38 + 0.00 / [( 1 - 0.29 / 103.63 ) * 137.90 ]$$

$$= 0.003$$

Check Passes [must be < 1.0]

**SUMMARY OF RESULTS (EXTERNAL PRESSURE):**

**MEMBRANE STRESS SUMMARY,**

High Stress (Highest % of Allowable)	0.86	N./mm <sup>2</sup>
High Stress Percentage	0.74	%
M.A.W.P. for Membrane Stresses	135.55	bars

**BENDING STRESS SUMMARY,**

High Stress (Highest % of Allowable)	49.97	N./mm <sup>2</sup>
High Stress Percentage	24.16	%
M.A.W.P. for Bending Stresses	4.14	bars

**TOTAL STRESS SUMMARY,**

High Stress (Highest % of Allowable)	50.45	N./mm <sup>2</sup>
High Stress Percentage	24.39	%
M.A.W.P. for Total Stresses	4.10	bars

**SUMMARY OF COLUMN STABILITY CHECKS:**

Plate Stability Checks	(Equation 1)	PASS
Cross Section Stability Check	(Equation 14)	PASS

PV Elite is a trademark of Intergraph CADWorx & Analysis Solutions, Inc. 2019

**Rectangular Vessel Results For Item 1 : A1**

**SUMMARY OF RESULTS (EXTERNAL PRESSURE):**

**MEMBRANE STRESS SUMMARY,**

High Stress (Highest % of Allowable)	0.86	N./mm <sup>2</sup>
High Stress Percentage	0.74	%
M.A.W.P. for Membrane Stresses	135.55	bars

**BENDING STRESS SUMMARY,**





High Stress (Highest % of Allowable)	49.97	N./mm <sup>2</sup>
High Stress Percentage	24.16	%
M.A.W.P. for Bending Stresses	4.14	bars

**TOTAL STRESS SUMMARY,**





High Stress (Highest % of Allowable)	50.45	N./mm <sup>2</sup>
High Stress Percentage	24.39	%
M.A.W.P. for Total Stresses	4.10	bars

**SUMMARY OF COLUMN STABILITY CHECKS:**

Plate Stability Checks	(Equation 1)	PASS
Cross Section Stability Check	(Equation 14)	PASS

 	<p>Toase-che Park Sanati Gohar Ofogh Petrochemical Co.</p> <p><b>CONCEPTUAL, BASIC and DETAIL DESIGN ENGINEERING OF STYRENE PARK OFFSITE</b></p>	 	
	<p>Document Title: Mechanical Calculation</p>		
	<p>Document No.: EI027-DMF-VD-ME-CAL-006</p>	<p>Rev. R1</p>	<p>Page 4 of 56</p>

## 4. Tube Buckling Calculation

 	<p>Toase-che Park Sanati Gohar Ofogh Petrochemical Co.</p> <p><b>CONCEPTUAL, BASIC and DETAIL DESIGN ENGINEERING OF STYRENE PARK OFFSITE</b></p>	 
	Document Title: Mechanical Calculation	
	Document No.: EI027-DMF-VD-ME-CAL-006	Rev. R1

## 7.1 Notations

$W_h =$  *Wight of Header*

$W_f =$  *Weight of Fluid in Header*

$A =$  *Length of Header*

$B =$  *Width of Header*

$C =$  *Height of Header*

$N =$  *Number of Tubes in Bundle*

$d_o =$  *Outside Diameter of Tube*

$t =$  *Wall Thickness of Tube*

$L =$  *Length of Tube*

$L_e =$  *Effective Length of Tube (for Buckling)*

$I =$  *Moment of Inertia of Tube*

$E =$  *Module of Elasticity for Tube Material*

$F_{ax} =$  *Total Axial Load on One Tube*

$F_n =$  *Total Normal Load Exerted on Header*

$F_f =$  *Friction Load due to  $F_n$*

$F_{cr} =$  *Buckling Critical Load*



$\mu =$  *Friction Coefficient*

## 7.2 Introduction

The tube buckling calculation is done by using Euler's column formula.

$$F_{cr} = \frac{\pi^2 EI}{L_e^2}$$

The end condition is shown in Figure 5.1 below:

	<p>Toase-che Park Sanati Gohar Ofogh Petrochemical Co. <b>CONCEPTUAL, BASIC and DETAIL DESIGN ENGINEERING OF STYRENE PARK OFFSITE</b></p>	 
	<p>Document Title: Mechanical Calculation</p>	
	<p>Document No.: EI027-DMF-VD-ME-CAL-006</p>	<p>Rev. R1      Page 6 of 56</p>

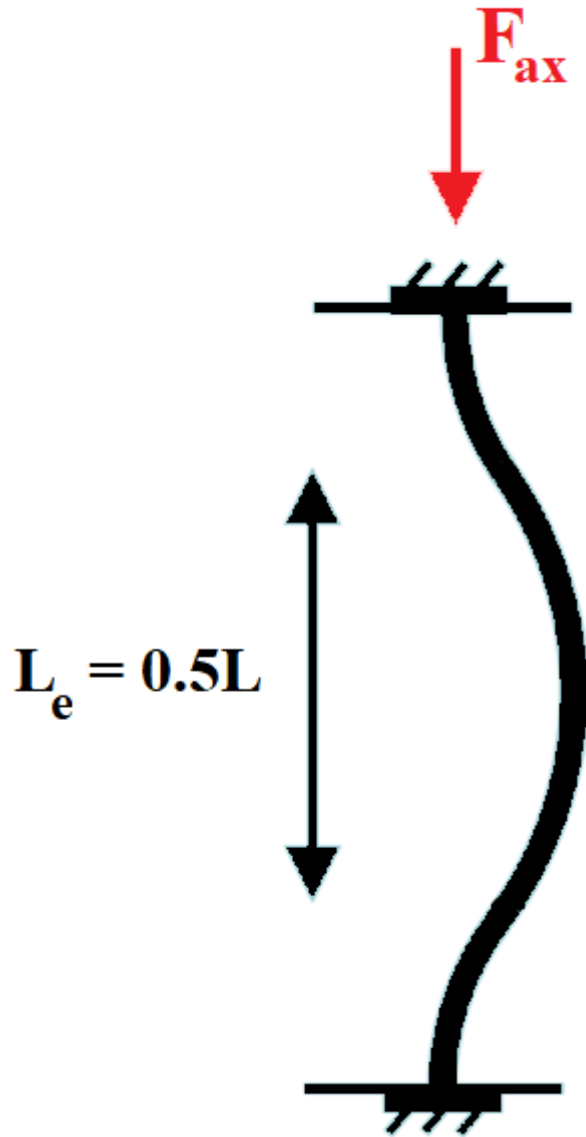

Figure 5.1 End Condition for Tube Under Axial Loading

Nozzle loads are two times the values in Table 4 of API 661.

For loads exerted on the header of this item see figure 5.2 below:

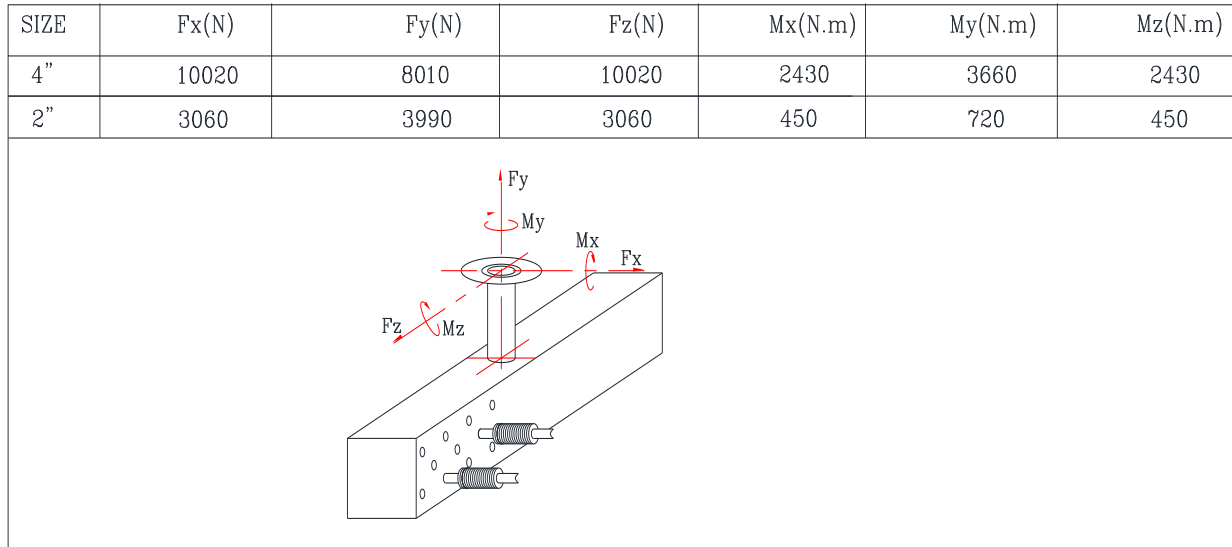





Figure 5.2 Nozzle Loads

### 7.3 Calculation

$W_h = 446 \text{ kg}$	$N = 140$
$W_f = 97 \text{ kg}$	$d_o = 25.4 \text{ mm}$
$A = 2510 \text{ mm}$	$t = 1.651 \text{ mm}$
$B = 140 \text{ mm}$	$L = 6096 \text{ mm}$
$C = 389 \text{ mm}$	$L_e = 0.5 \times L = 3048 \text{ mm}$
$\mu = 0.2 \text{ (Steel on Teflon)}$	$I = \frac{\pi[d_o^4 - (d_o - 2t)^4]}{64} = 8717.8 \text{ mm}^4$
	$E = 195 \text{ GPa (at } 100^\circ\text{C)}$

Because the sliding header (rear header) has no process nozzles, no nozzle load acts against the longitudinal expansion of tubes. Therefore, only weight loads are to be considered.

$$F_n = (W_h + W_f)g = (446 + 97) \times 9.81 = 5327 \text{ N}$$

 	<p>Toase-che Park Sanati Gohar Ofogh Petrochemical Co.</p> <p><b>CONCEPTUAL, BASIC and DETAIL DESIGN ENGINEERING OF STYRENE PARK OFFSITE</b></p>	 
	Document Title: Mechanical Calculation	
	Document No.: EI027-DMF-VD-ME-CAL-006	Rev. R1      Page 8 of 56

$$F_f = \mu \times F_n = 0.2 \times 5327 = 1065 \text{ N}$$

$$F_{ax} = \frac{F_f}{N} = \frac{1065}{140} = 7.61 \text{ N}$$

$$F_{cr} = \frac{\pi^2 EI}{L_e^2} = \frac{\pi^2 \times 195 \times 10^9 \times 8.7178 \times 10^{-9}}{(3048 \times 10^{-3})^2} = 1804 \text{ N}$$

$$F_{ax} < F_{cr} \quad \rightarrow \quad \text{No Buckling!}$$

5.calculate Tube to Tube sheet joint as per UW-20.

REFE TO ASME VIII DIV1,UW-20 SKETCH "C"

$$a_r = 2\sqrt{(0.75do)^2 + 1.07t(do - t)} - 0.75do$$

$$a_r = 2.14 \text{ mm}$$

$$ac = af + ag$$

$$ac = 3 \text{ mm}$$

$$t = 1.65 \text{ mm}$$

$$ac > a_r \text{ or } t$$

$$3 > 2.14 \text{ or } 1.65$$

ok

6. pv file for thk calc for tube

**Input Echo, Component 1, Description: TUBE**

Design Internal Pressure	P	22.00	bars
Temperature for Internal Pressure		120.00	C
User Entered Minimum Design Metal Temperature		-45.00	C
Design External Pressure	PEXT	1.00	bars
Temperature for External Pressure		120.00	C
External Pressure Chart Name		CS-2	
Include Hydrostatic Head Components		NO	
Material Specification (Not Normalized)		SA-334 6	
Material UNS Number		K03006	
Material Form used	Smls. & wld. tube		
Allowable Stress At Temperature	S	117.905	N./mm^2
Allowable Stress At Ambient	SA	117.905	N./mm^2
Yield Stress At Temperature	Sy	217.360	N./mm^2
Curve Name for Chart UCS 66			
Joint efficiency for Shell Joint	E	1.00	
Design Length of Section	L	6096.000	mm.
Length of Cylinder for Volume Calcs.	CYLLLEN	6096.000	mm.
Outside Diameter of Cylindrical Shell	D	25.400	mm.
Minimum Thickness of Pipe or Plate	T	1.6500	mm.
Shell/Head Int. Corrosion Allowance	CA	0.0000	mm.
Skip UG-16(b) Min. thickness calculation		YES	
Type of Element:		Cylindrical Shell	

**REV.03**

**Internal pressure results, Shell Number 1, Desc.: TUBE**

ASME Code, Section VIII, Division 1, 2017

**Thickness Due to Internal Pressure (Tr):**

$$= (P * (D/2 - CAE)) / (S * E + 0.4 * P) \text{ per Appendix 1-1 (a) (1)}$$

$$= (22.00 * (25.4000/2 - 0.000)) / (117.90 * 1.00 + 0.4 * 22.00)$$

$$= 0.2352 + 0.0000 = 0.2352 \text{ mm.}$$

**Max. All. Working Pressure at Given Thickness (MAWP):**

$$= (S * E * (T - CA - CAE)) / ((D/2 - CAE) - 0.4 * (T - CA - CAE)) \text{ per Appendix 1-1 (a) (1)}$$

$$= (117.90 * 1.00 * (1.6500)) / (25.4000/2 - 0.000 - 0.4 * 1.6500)$$

$$= 161.57 \text{ bars}$$

**Maximum Allowable Pressure, New and Cold (MAPNC):**

$$= (SA * E * T) / (D/2 - 0.4 * T) \text{ per Appendix 1-1 (a) (1)}$$

$$= (117.90 * 1.00 * 1.6500) / (25.4000/2 - 0.4 * 1.6500)$$

$$= 161.57 \text{ bars}$$

**Actual stress at given pressure and thickness (Sact):**

$$= (P * ((D/2 - CAE) - 0.4 * (T - CA - CAE))) / (E * (T - CA - CAE))$$

$$= (22.00 * ((25.4000/2 - 0.000) - 0.4 * (1.6500))) / (1.00 * (1.6500))$$

$$= 16.05 \text{ N./mm}^2$$

**SUMMARY OF INTERNAL PRESSURE RESULTS:**

Required Thickness plus Corrosion Allowance, Trca		0.2352	mm.
Actual Thickness as Given in Input		1.6500	mm.
Maximum Allowable Working Pressure	MAWP	161.571	bars
Maximum Allowable Pressure, NC	MAPNC	161.571	bars
Design Pressure as Given in Input	P	22.000	bars

**Hydrostatic Test Pressures ( Measured at High Point ):**

Hydrotest per UG-99(b); 1.3 * MAWP * Sa/S		210.04	bars
Hydrotest per UG-99(c); 1.3 * MAPNC		210.04	bars
Pneumatic per UG-100 ; 1.1 * MAWP * Sa/S		177.73	bars

% Elongation per Table UG-79-1 ( 50 \* tnom/Rf \* (1-Rf/Ro) ) 6.947 %

Note: Please Check Requirements of UCS-79 as Elongation is > 5%.

FileName : TUBE C.-REV.01

Shell Analysis : TUBE

Item: 1 4:25p Jul 28,2024

**Minimum Design Metal Temperature :**

Impact Test Temperature provided per Specification -46 C  
 Min. Metal Temp. w/o impact per UG-20(f) -29 C

**External Pressure Results, Shell Number 1, Desc.: TUBE**

**ASME Code, Section VIII, Division 1, 2017**

External Pressure Chart CS-2 at 120.00 C  
 Elastic Modulus for Material 199943392.00 KPa.

**Results for Max. Allowable External Pressure (Emawp):**

Corroded Thickness of Shell TCA 1.6500 mm.  
 Outside Diameter of Shell ODCA 25.400 mm.  
 Design Length of Cylinder or Cone SLEN 6096.000 mm.  
 Diameter / Thickness Ratio (D/T) 15.3939  
 Length / Diameter Ratio LD 50.0000  
 Geometry Factor, A f(DT,LD) A 0.0046419  
 Materials Factor, B, f(A, Chart) B 118.4957 N./mm<sup>2</sup>  
 Maximum Allowable Working Pressure 102.63 bars  
 EMAWP = (4\*B)/(3\*(D/T)) = ( 4 \*118.4957 )/( 3 \*15.3939 ) = 102.6281

**Results for Req'd Thickness for Ext. Pressure (Tca):**

Corroded Thickness of Shell TCA 0.2236 mm.  
 Outside Diameter of Shell ODCA 25.400 mm.  
 Design Length of Cylinder or Cone SLEN 6096.000 mm.  
 Diameter / Thickness Ratio (D/T) 113.6053  
 Length / Diameter Ratio LD 50.0000  
 Geometry Factor, A f(DT,LD) A 0.0000852  
 Materials Factor, B, f(A, Chart) B 8.5211 N./mm<sup>2</sup>  
 Maximum Allowable Working Pressure 1.00 bars  
 EMAWP = (4\*B)/(3\*(D/T)) = ( 4 \*8.5211 )/( 3 \*113.6053 ) = 1.0000

**Results for Maximum Length Calculation: No Conversion**

Corroded Thickness of Shell TCA 1.6500 mm.  
 Outside Diameter of Shell ODCA 25.400 mm.  
 Design Length of Cylinder or Cone SLEN 0.580E+34 mm.  
 Diameter / Thickness Ratio (D/T) 15.3939  
 Length / Diameter Ratio LD 50.0000  
 Geometry Factor, A f(DT,LD) A 0.0046419  
 Materials Factor, B, f(A, Chart) B 118.4957 N./mm<sup>2</sup>  
 Maximum Allowable Working Pressure 102.63 bars  
 EMAWP = (4\*B)/(3\*(D/T)) = ( 4 \*118.4957 )/( 3 \*15.3939 ) = 102.6281

**Summary of External Pressure Results:**

Allowable Pressure at Corroded thickness 102.63 bars  
 Required Pressure as entered by User 1.00 bars  
 Required Thickness including Corrosion all. 0.2236 mm.  
 Actual Thickness as entered by User 1.6500 mm.  
 Maximum Length for Thickness and Pressure 0.5804E+34 mm.  
 Actual Length as entered by User 6096.00 mm.

**Weight and Volume Results, No C.A. :**

Volume of Shell Component VOLMET 750485.6 mm.<sup>3</sup>  
 Weight of Shell Component WMET 5.8 Kgf  
 Inside Volume of Component VOLID 2338403.2 mm.<sup>3</sup>  
 Weight of Water in Component WWAT 2.3 Kgf

FileName : TUBE C.-REV.01

Vessel Results Summary

Item: 1 4:25p Jul 28,2024

**Summary for shell/head, Div 1:**

Description	MAPNC bars	MAWP bars	Min. T mm.	Tr-int mm.	Tr-ext mm.	EMAWP bars
TUBE	161.571	161.571	1.650	0.235	0.224	102.628
Minimum MAWP	161.571	161.571				102.628

Note: Req'd. thk. reported above includes Corrosion Allowance.





Total Shell/Head weight is (New-Cold)	5.8 Kgf
Total Shell/Head weight is (Corroded)	5.8 Kgf
Total Shell/Head weight, filled with Water (New)	8.2 Kgf
Total Shell/Head volume is (New-Cold)	2338403.0 mm.**3
Total Shell/Head volume is (Corroded)	2338403.0 mm.**3

**Least MAWP and Overall Weight Results :**

The Least MAWP (N C) for TUBE was 161.57 bars 0.  
 The Least MAWP (Cor) for TUBE was 161.57 bars 0.

The total sum of the Weights ( N C ) was 5.82 Kgf 0.  
 The total sum of the Weights ( Cor ) was 5.82 Kgf 0.

**PV Elite is a trademark of Intergraph CADWorx & Analysis Solutions, Inc. 2019**

 	<p style="text-align: center;">Toase-eh Park Sanati Gohar Ofogh Petrochemical Co.</p> <p style="text-align: center;"><b>CONCEPTUAL, BASIC and DETAIL DESIGN ENGINEERING OF STYRENE PARK OFFSITE</b></p>	  
	Document Title: Mechanical Calculation	
	Document No.: EI027-DMF-VD-ME-CAL-006	Rev. R1

## 7. MAWP Summary

Table 7.1 provides a summary of the Maximum Allowable Working Pressure (MAWP) for the components of the air-cooled heat exchanger.

Table 2.1

No.	COMPONENT	MAWP (bar)	REMARKS
1	Header (Front)	30.5	See Page 27
2	Header (Rear)	29	See Page 36
3	Tube	161	See Page 12
4	Nozzle 4" (Inlet)	194	See Page 13
5	Nozzle 2" (Outlet)	491.1	See Page 14
6	ANSI Flange, Class #300	45	ASME B16.5 Table 2-1.1

From table 7.1 above:

**MAWP of the Vessel = 29 bar**

### 7.1 Calculation of Hydrostatic Test Pressure:

Based on MAWP from table 2.1 and ASME Sec. VIII Division 1, UG-99 (b):

$$P_{Hydro-test} = 1.3 \times (MAWP) \times \frac{S_{allow @ T_{test}}}{S_{allow @ T_{design}}}$$

$$P_{Hydro-test} = 1.3 \times 29 \times 1 = 37.7 \text{ bar}$$

## 8. MDMT Summary

REV.03

Table 8.1 provides a summary of the calculated Minimum Design Metal Temperature (MDMT) for the components of the air-cooled heat exchanger.

Table 8.1

COMPONENT	MAT.	GOVERNING THK. (mm)	MDT (°C)	UCS-66 CURVE	BASIC MDMT (°C)
Tube Sheet, Top & Bottom & End Plate	SA-516 Gr. 70 N	20	-45	D	-39
Tube	SA-334 Gr.6	1.65	-45	[NOTE 1]	-45
Nozzle, Pipe	SA-333 Gr. 6	13.5	-45	[NOTE 1]	-45
Nozzle, flange (ASME B16.5)	SA-350LF2 CL.1N	13.5	-45	[NOTE 1]	-45
Nozzle, Flange (ASME B16.5)	SA-350LF2 CL.1N	16.6	-45	[NOTE 1]	-45
STUD BOLT & NUT	SA-320 Gr.L7 / SA 194 Gr.7		-45	[NOTE 1]	-45

Notes:

- 1) IMPACT TESTED MATERIAL

According to table 8.1 above, the warmest calculated MDMT of the air-cooled heat exchanger components is:

**MDMT = -39 °C**

Since the calculated MDMT for the air cooler is warmer than Minimum Design Temperature (MDT), the plate material (SA-516-Gr.70) SHALL BE IMPACT TESTED AT -45 °C.

SA-516-Gr.70 N