



Toase-eh Park Sanati Gohar Ofogh
Petrochemical Co.
**CONCEPTUAL, BASIC and DETAIL DESIGN
ENGINEERING OF STYRENE PARK OFFSITE**



dttdamafin
thermal technology

Document Title: Mechanical Calculation

Document No.: EI027-DMF-VD-ME-CAL-006

Rev. R0

Page 1 of 56

STYRENE PARK OFFSITE

**Document Title:
Mechanical Calculation**

Rev.	Issued Date	DESCRIPTION	PREPARED	CHECKED	APPROVED
R0	02-06-2024	IFA	S.SOLGI	J.BEIGLOU	A.GHOLIZADEH



Toase-eh Park Sanati Gohar Ofogh
Petrochemical Co.
**CONCEPTUAL, BASIC and DETAIL DESIGN
ENGINEERING OF STYRENE PARK OFFSITE**



Document Title: Mechanical Calculation

Document No.: EI027-DMF-VD-ME-CAL-006

Rev. R0

Page 2 of 56

REVISION RECORD SHEET

Page Page	Revisions							Page	Revisions						
	R0	R1	R2	R3	R4	R5	R6		R0	R1	R2	R3	R4	R5	R6
1	X							41	X						
2	X							42	X						
3	X							43	X						
4	X							44	X						
5	X							45	X						
6	X							46	X						
7	X							47	X						
8	X							48	X						
9	X							49	X						
10	X							50	X						
11	X							51	X						
12	X							52	X						
13	X							53	X						
14	X							54	X						
15	X							55	X						
16	X							56	X						
17	X							57							
18	X							58							
19	X							59							
20	X							60							
21	X							61							
22	X							62							
23	X							63							
24	X							64							
25	X							65							
26	X							66							
27	X							67							
28	X							68							
29	X							69							
30	X							70							
31	X							71							
32	X							72							
33	X							73							
34	X							74							
35	X							75							
36	X							76							
37	X							77							
38	X							78							
39	X							79							
40	X							80							

Page 3 of 89	Mechanical Calculation	Rev.	Class
Document Number		D00	1
Client Number			

TABLE OF CONTENTS

Section	Contents	Page No.
1	Mechanical Calculation for Design Case	4
2	Calculation by PV Elite / CodeCalc	19
3	Nozzle N1 FE Analysis by NozzlePro (FE661)	28
4	Nozzle N2 FE Analysis by NozzlePro (FE661)	42

	JOB N°: 1158	Rev 00	Date 01.JUN.202S	Issued by S.SOLGI	Approved by A.GHOLIZADEH
	ITEM : A				

VESSEL UNDER INTERNAL PRESSURE

PAGE 2

PLUG HEADER (Fig. 13-2(a) Sketch (8)) **FRONT HEADER(DESIGN)**

Code ASME VIII Div. 1 Ed. 2017

Appendix 13 : 13-9 (c)

DESIGN CONDITIONS

Internal design pressure	P = 2.200 Mpa
Design temperature	θ = 120.0 °C
Corrosion allowance	c = 3.00 mm
Header Material	SA-516-GR70N
Maximum allowable stress value at design temperature	S = 138.0 Mpa
Maximum allowable stress (Membrane + bending)	1.5 S = 207.0 Mpa
Actual inside total height of end plate header	h _{αt} = 349.00 mm
Actual inside height of the greatest compartment	h _o = 140.00 mm
Actual inside width of header	H _o = 100.00 mm
Thickness of top and bottom plates	t ₀₁ = 20.00 mm
Thickness of plug and tubesheet	t ₀₂ = 20.00 mm
Thickness of partition or stiffener	t ₀₃ = 12.000 mm
Thickness of end plates	t ₀₅ = 20.000 mm
Plug hole diameter	d _e = 25.700 mm
Horizontal pitch of tubes	P _h = 69.850 mm
Ligament efficiency E _i = (p _h - d _e) / p _h	E _i = 0.632
Weld joint efficiency	E _w = 0.850
Ligament efficiency of stiffener	E _s = 0.600

CORRODED DIMENSIONS

$$\begin{aligned}
 H &= H_o + 2 \cdot c = 106.00 \text{ mm} & c_1 &= \frac{t_1}{2} = 8.50 \text{ mm} \\
 h &= h_o + 2 \cdot c = 146.00 \text{ mm} \\
 h_t &= h_{\alpha t} + 2 \cdot c = 355.00 \text{ mm} & c_2 &= \frac{t_2}{2} = 8.50 \text{ mm} \\
 t_1 &= t_{01} - c = 17.00 \text{ mm} & t_3 &= t_{03} - 2 \cdot c = 6.00 \text{ mm} \\
 t_2 &= t_{02} - c = 17.00 \text{ mm} & t_5 &= t_{05} - c = 17.00 \text{ mm}
 \end{aligned}$$

MOMENT OF INERTIA OF STRIP OF THICKNESS

$$\begin{aligned}
 I_1 &= \frac{t_1^3}{12} = 409.4 \text{ mm}^4 \\
 I_2 &= \frac{t_2^3}{12} = 409.4 \text{ mm}^4
 \end{aligned}$$

VESSEL PARAMETER

$$\begin{aligned}
 \alpha &= \frac{H}{h} = 0.7260 \\
 K &= \frac{I_2}{I_1} \alpha = 0.7260
 \end{aligned}$$

 <p>Damafin Thermal Technology Co.</p>	<p>JOB N°: 1158</p> <p>ITEM : A</p>	<p>Rev 00</p>	<p>Date 01.JUN.2025</p>	<p>Issued by S.SOLGI</p>	<p>Approved by A.GHOLIZADEH</p>
---	---	-------------------	-----------------------------	------------------------------	-------------------------------------

VESSEL UNDER INTERNAL PRESSURE

PAGE 3

STRESS CALCULATION

Top and bottom plates

Membrane stress

$$(13) S_m = \frac{P \cdot h}{2 \cdot t_1 \cdot E_w} \left[3 - \left[\frac{6 + K(11 - \alpha^2)}{3 + 5 \cdot K} \right] \right] \quad S_m = 10.5 \text{ Mpa}$$

$$S_m < S \quad \text{Design OK}$$

Bending stress

$$(16) (S_b)_N = \frac{P \cdot c_1}{24 \cdot I_1} \left[-3 \cdot H^2 + 2 \cdot h^2 \frac{(3 + 5 \cdot \alpha^2 \cdot K)}{3 + 5 \cdot K} \right] \quad (S_b)_N = 4.0 \text{ Mpa}$$

$$(17) (S_b)_Q = \frac{P \cdot h^2 \cdot c_1}{12 \cdot I_1 \cdot E_w} \left[\frac{(3 + 5 \cdot \alpha^2 \cdot K)}{3 + 5 \cdot K} \right] \quad (S_b)_Q = 70.7 \text{ Mpa}$$

Total stress

$$(20) (S_T)_N = \text{Eq. (13)} + \text{Eq. (16)} \quad (S_T)_N = 14.6 \text{ Mpa}$$

$$(S_T)_N < 1.5 S \quad \text{Design OK}$$

$$(21) (S_T)_Q = \text{Eq. (13)} + \text{Eq. (17)} \quad (S_T)_Q = 81.3 \text{ Mpa}$$

$$(S_T)_Q < 1.5 S \quad \text{Design OK}$$

 <p>Damafin Thermal Technology Co.</p>	<p>JOB N°: 1158</p> <p>ITEM : A</p>	<p>Rev 00</p>	<p>Date 01.JUN.2025</p>	<p>Issued by S.SOLGI</p>	<p>Approved by A.GHOLIZADEH</p>
---	---	-------------------	-----------------------------	------------------------------	-------------------------------------

VESSEL UNDER INTERNAL PRESSURE

PAGE 4

STRESS CALCULATION

Plug and tubesheet

Membrane stress

$$(14) S_m = \frac{P \cdot H}{2 \cdot t_2 \cdot E_1}$$

$$S_m = 10.9 \text{ Mpa}$$

$$S_m < S \text{ Design OK}$$

Bending stress

$$(18) (S_b)_M = \frac{P \cdot h^2 \cdot c_2}{12 \cdot I_2} \left[\frac{(3 + K(6 - \alpha^2))}{3 + 5 \cdot K} \right]$$

$$(S_b)_M = 85.3 \text{ Mpa}$$

$$(19) (S_b)_Q = \frac{P \cdot h^2 \cdot c_2}{12 \cdot I_2} \left[\frac{(3 + 5 \cdot \alpha^2 \cdot K)}{3 + 5 \cdot K} \right]$$

$$(S_b)_Q = 60.1 \text{ Mpa}$$

Total stress

$$(22) (S_T)_M = \text{Eq. (14)} + \text{Eq. (18)}$$

$$(S_T)_M = 96.2 \text{ Mpa}$$

$$(S_T)_M < 1.5 S \text{ Design OK}$$

$$(23) (S_T)_Q = \text{Eq. (14)} + \text{Eq. (19)}$$

$$(S_T)_Q = 71.0 \text{ Mpa}$$

$$(S_T)_Q < 1.5 S \text{ Design OK}$$

 <p>Damafin Thermal Technology Co.</p>	<p>JOB N°: 1158</p> <p>ITEM : A</p>	<p>Rev 00</p>	<p>Date 01.JUN.2025</p>	<p>Issued by S.SOLGI</p>	<p>Approved by A.GHOLIZADEH</p>
---	---	-------------------	-----------------------------	------------------------------	-------------------------------------

VESSEL UNDER INTERNAL PRESSURE

PAGE 5

STRESS CALCULATION

Partition plate or stiffener

Membrane stress

$$E = \min (0.6 , E_s) = 0.6000$$

$$(15) S_m = \frac{P \cdot h}{2 \cdot t_3 \cdot E} \left[\frac{6 + K (11 - \alpha^2)}{3 + 5 \cdot K} \right] \quad S_m = 91.5 \text{ Mpa}$$

$$S_m < S \quad \text{Design OK}$$

End Plate UG-34 (c) (3)

For operating conditions

$$d = \min (h_t , H) \quad d = 106.00 \text{ mm}$$

$$D = \max (h_t , H) \quad D = 355.00 \text{ mm}$$

$$C = 0.20$$

$$Z = 3.4 \cdot \frac{2.4 \cdot d}{D} = 2.683$$

$$Z = \min (Z , 2.5) = 2.500$$

$$t_{0.5} = d \sqrt{\frac{Z \cdot C \cdot P}{S \cdot E_w}} + c = 13.28 \text{ mm}$$

$$\text{Used thickness : } t_{0.5} = 13.28 \text{ mm}$$

	JOB N°: 1158	Rev 00	Date 01.JUN.202S.SOLGI	Issued by S.SOLGI	Approved by A.GHOLIZADEH
	ITEM : A				

VESSEL UNDER INTERNAL PRESSURE

PAGE 6

PLUG HEADER (Fig. 13-2(a) Sketch (7)) **REAR HEADER (DESIGN)**

Code ASME VIII Div. 1 Ed. 2017

Appendix 13 : 13-9 (b)

DESIGN CONDITIONS

Internal design pressure	P = 2.200 Mpa
Design temperature	θ = 120.0 °C
Corrosion allowance	c = 3.00 mm
Header Material	SA-516-GR70N
Maximum allowable stress value at design temperature	S = 138.0 Mpa
Maximum allowable stress (Membrane + bending)	1.5 S = 207.0 Mpa
Actual inside total height of end plate header	h _{αt} = 288.00 mm
Actual inside height of the greatest compartment	h _o = 138.00 mm
Actual inside width of header	H _o = 100.00 mm
Thickness of top and bottom plates	t ₀₁ = 20.00 mm
Thickness of plug and tubesheet	t ₀₂ = 20.00 mm
Thickness of partition or stiffener	t ₀₃ = 12.000 mm
Thickness of end plates	t ₀₅ = 20.000 mm
Plug hole diameter	d _e = 25.700 mm
Horizontal pitch of tubes	P _h = 69.850 mm
Ligament efficiency E _i = (p _h - d _e) / p _h	E _i = 0.632
Weld joint efficiency	E _w = 0.850
Ligament efficiency of stiffener	E _s = 0.600

CORRODED DIMENSIONS

$$\begin{aligned}
 H &= H_o + 2 \cdot c = 106.00 \text{ mm} & c_1 &= \frac{t_1}{2} = 8.50 \text{ mm} \\
 h &= h_o + 2 \cdot c = 144.00 \text{ mm} \\
 h_t &= h_{\alpha t} + 2 \cdot c = 294.00 \text{ mm} & c_2 &= \frac{t_2}{2} = 8.50 \text{ mm} \\
 t_1 &= t_{01} - c = 17.00 \text{ mm} & t_3 &= t_{03} - 2 \cdot c = 6.00 \text{ mm} \\
 t_2 &= t_{02} - c = 17.00 \text{ mm} & t_5 &= t_{05} - c = 17.00 \text{ mm}
 \end{aligned}$$

MOMENT OF INERTIA OF STRIP OF THICKNESS

$$\begin{aligned}
 I_1 &= \frac{t_1^3}{12} = 409.4 \text{ mm}^4 \\
 I_2 &= \frac{t_2^3}{12} = 409.4 \text{ mm}^4
 \end{aligned}$$

VESSEL PARAMETER

$$\begin{aligned}
 \alpha &= \frac{H}{h} = 0.7361 \\
 K &= \frac{I_2}{I_1} \alpha = 0.7361
 \end{aligned}$$

 <p>Damafin Thermal Technology Co.</p>	<p>JOB N°: 1158</p> <p>ITEM : A</p>	<p>Rev 00</p>	<p>Date 01.JUN.2025</p>	<p>Issued by S.SOLGI</p>	<p>Approved by A.GHOLIZADEH</p>
---	---	-------------------	-----------------------------	------------------------------	-------------------------------------

VESSEL UNDER INTERNAL PRESSURE

PAGE 7

STRESS CALCULATION

Top and bottom plates

Membrane stress

$$(1) S_m = \frac{P \cdot h}{4 \cdot t_1 \cdot E_w} \left[4 - \left[\frac{2 + K(5 - \alpha^2)}{1 + 2 \cdot K} \right] \right] \quad S_m = 10.2 \text{ Mpa}$$

$$S_m < S \quad \text{Design OK}$$

Bending stress

$$(4) (S_b)_N = \frac{P \cdot c_1}{24 \cdot I_1} \left[-3 \cdot H^2 + 2 \cdot h^2 \frac{(1 + 2 \cdot \alpha^2 \cdot K)}{1 + 2 \cdot K} \right] \quad (S_b)_N = 6.8 \text{ Mpa}$$

$$(5) (S_b)_Q = \frac{P \cdot h^2 \cdot c_1}{12 \cdot I_1 \cdot E_w} \left[\frac{(1 + 2 \cdot \alpha^2 \cdot K)}{1 + 2 \cdot K} \right] \quad (S_b)_Q = 67.5 \text{ Mpa}$$

Total stress

$$(8) (S_T)_N = \text{Eq. (1)} + \text{Eq. (4)} \quad (S_T)_N = 17.0 \text{ Mpa}$$

$$(S_T)_N < 1.5 S \quad \text{Design OK}$$

$$(8) (S_T)_Q = \text{Eq. (1)} + \text{Eq. (5)} \quad (S_T)_Q = 77.7 \text{ Mpa}$$

$$(S_T)_Q < 1.5 S \quad \text{Design OK}$$

 <p>Damafin Thermal Technology Co.</p>	<p>JOB N°: 1158</p> <p>ITEM : A</p>	<p>Rev 00</p>	<p>Date 01.JUN.2025</p>	<p>Issued by S.SOLGI</p>	<p>Approved by A.GHOLIZADEH</p>
---	---	-------------------	-----------------------------	------------------------------	-------------------------------------

VESSEL UNDER INTERNAL PRESSURE

PAGE 8

STRESS CALCULATION

Plug and tubesheet

Membrane stress

$$(2) S_m = \frac{P \cdot H}{2 \cdot t_2 \cdot E_t}$$

$$S_m = 10.9 \text{ Mpa}$$

$$S_m < S \quad \text{Design OK}$$

Bending stress

$$(6) (S_b)_M = \frac{P \cdot h^2 \cdot c_2}{12 \cdot I_2} \left[\frac{(1 + K(3 - \alpha^2))}{1 + 2 \cdot K} \right]$$

$$(S_b)_M = 89.7 \text{ Mpa}$$

$$(7) (S_b)_Q = \frac{P \cdot h^2 \cdot c_2}{12 \cdot I_2} \left[\frac{(1 + 2 \cdot \alpha^2 \cdot K)}{1 + 2 \cdot K} \right]$$

$$(S_b)_Q = 57.4 \text{ Mpa}$$

Total stress

$$(10) (S_T)_M = \text{Eq. (2)} + \text{Eq. (6)}$$

$$(S_T)_M = 100.5 \text{ Mpa}$$

$$(S_T)_M < 1.5 S \quad \text{Design OK}$$

$$(11) (S_T)_Q = \text{Eq. (2)} + \text{Eq. (7)}$$

$$(S_T)_Q = 68.2 \text{ Mpa}$$

$$(S_T)_Q < 1.5 S \quad \text{Design OK}$$

	JOB N°: 1158	Rev 00	Date 01.JUN.2025	Issued by S.SOLGI	Approved by A.GHOLIZADEH
	ITEM : A				

VESSEL UNDER INTERNAL PRESSURE

STRESS CALCULATION

Partition plate or stiffener

Membrane stress

$$E = \min (0.6 , E_s) = 0.6000$$

$$(3) S_m = \frac{P \cdot h}{2 \cdot t_3 \cdot E} \left[\frac{2 + K (5 - \alpha^2)}{1 + 2 \cdot K} \right] \quad S_m = 94.0 \text{ Mpa}$$

$$S_m < S \quad \text{Design OK}$$

End Plate UG-34 (c) (3)

For operating conditions

$$d = \min (h_t , H) \quad d = 106.00 \text{ mm}$$

$$D = \max (h_t , H) \quad D = 294.00 \text{ mm}$$

$$C = 0.20$$

$$Z = 3.4 \cdot \frac{2.4 \cdot d}{D} = 2.535 \quad Z = \min (Z , 2.5) = 2.500$$

$$t_{0.5} = d \sqrt{\frac{Z \cdot C \cdot P}{S \cdot E_w}} + c = 13.28 \text{ mm}$$

$$\text{Used thickness : } t_{0.5} = 13.28 \text{ mm}$$

 <p>Damafin Thermal Technology Co.</p>	<p>JOB N°: 1158</p> <p>ITEM : A</p>	<p>Rev 00</p>	<p>Date 01.JUN.202S</p>	<p>Issued by S.SOLGI</p>	<p>Approved by A.GHOLIZADEH</p>
---	---	-------------------	-----------------------------	------------------------------	-------------------------------------

VESSEL UNDER INTERNAL PRESSURE

PAGE 10

TUBE 1"

Code ASME VIII Div. 1 Ed. 2017

Appendix 1 : 1-1

DESIGN CONDITIONS

Internal design pressure	P = 2.200 Mpa
Design temperature	θ = 120.0 °C
Material SA-334-6	
Maximum allowable stress value	S = 118.0 Mpa
Outside diameter	d _o = 25.40 mm
Corrosion allowance	c = 0.00 mm
Joint efficiency	E = 1.000

MINIMUM REQUIRED THICKNESS $P < 0.385 \cdot S$

$$t = \frac{P \cdot d_o}{2 (S \cdot E + 0.4 \cdot P)} + c = 0.24 \text{ mm}$$

Used thickness: $t = 1.65 \text{ mm}$

MAXIMUM ALLOWABLE WORKING PRESSURE

$$P_a = \frac{2 \cdot S \cdot E (t - c)}{(d_o - 0.8 (t - c))} = 16.171 \text{ Mpa}$$

SERVICE STRESS

$$S_m = \frac{P \cdot (d_o - 0.8 (t - c))}{2 \cdot E (t - c)} = 16.1 \text{ Mpa}$$

	JOB N°: 1158	Rev 00	Date 01.JUN.202S	Issued by S.SOLGI	Approved by A.GHOLIZADEH
	ITEM : A				

VESSEL UNDER INTERNAL PRESSURE

NOZZLE INLET 4" ,WN ,SCH 160,#300

Code ASME VIII Div. 1 Ed. 2017

Appendix 1 : 1-1

DESIGN CONDITIONS

Internal design pressure	P = 2.200 Mpa
Design temperature	θ = 120.0 °C
Material SA 333 GR 6	
Maximum allowable stress value	S = 118.0 Mpa
Outside diameter	d ₀ = 114.00 mm
Corrosion allowance	c = 3.00 mm
Mill undertolerance	c ₁ = 1.70 mm
Joint efficiency	E = 1.000

MINIMUM REQUIRED THICKNESS $P < 0.385 \cdot S$

$$t = \frac{P \cdot d_0}{2(S \cdot E + 0.4 \cdot P)} + c + c_1 = 5.75 \text{ mm}$$

Used thickness: $t_n = 13.50 \text{ mm}$

$$R = \frac{d_0}{2} - t_n + c + c_1 = 48.20 \text{ mm} \quad t_n - c - c_1 < \frac{R}{2} \quad \text{design OK}$$

MAXIMUM ALLOWABLE WORKING PRESSURE

$$P_a = \frac{2 \cdot S \cdot E (t_n - c - c_1)}{(d_0 - 0.8(t_n - c - c_1))} = 19.42 \text{ Mpa}$$

SERVICE STRESS

$$S_m = \frac{P \cdot (d_0 - 0.8(t_n - c - c_1))}{2 \cdot E (t_n - c - c_1)} = 13.37 \text{ Mpa}$$

	JOB N°: 1158	Rev 00	Date 01.JUN.202S	Issued by S.SOLGI	Approved by A.GHOLIZADEH
	ITEM : A				

VESSEL UNDER INTERNAL PRESSURE

PAGE 12

FORGED NOZZLE OUTLET 2",LWN,SCH160,#300

Code ASME VIII Div. 1 Ed. 2017

UG-37 (c)

DESIGN CONDITIONS

Internal design pressure	P = 2.200 Mpa
Design temperature	θ = 120.0 °C
Material	SA-350 LF2 CLASS 1
Maximum allowable stress value	S = 138.0 Mpa
Actual inside diameter	d _i = 50.80 mm
Corrosion allowance	c = 3.00 mm
Machining undertolerance	c ₁ = 0.00 mm
Ligament efficiency	E = 1.000

MINIMUM REQUIRED THICKNESS

$$P < 0.385 \cdot S$$

$$R = \frac{d_i}{2} + c + c_1 = 28.40 \text{ mm}$$

$$t = \frac{P \cdot R}{(S \cdot E - 0.6 \cdot P)} + c + c_1 = 3.46 \text{ mm}$$

Used thickness: t_n = 15.85 mm

$$t_n - c - c_1 < \frac{R}{2} \quad \text{design OK}$$

MAXIMUM ALLOWABLE WORKING PRESSURE

$$P_a = \frac{S \cdot E (t_n - c - c_1)}{(R + 0.6 (t_n - c - c_1))} = 49.11 \text{ Mpa}$$

SERVICE STRESS

$$S_m = \frac{P \cdot (R + 0.6 (t_n - c - c_1))}{E (t_n - c - c_1)} = 6.18 \text{ Mpa}$$

VESSEL UNDER INTERNAL PRESSURE

EXTERNAL LOADS ON NOZZLE

Code ASME VIII Div. 1 Ed. 2017

INLET 4" ,WN ,SCH 160,#300

U-2(g)

DESIGN CONDITIONS

Internal design pressure	$P = 2.200 \text{ Mpa}$
Design temperature	$\theta = 120.0 \text{ }^\circ\text{C}$
Nozzle Material SA 333 GR 6	
Maximum allowable stress value	$S_n = 118.0 \text{ Mpa}$
Nozzle outside diameter	$d_o = 114.00 \text{ mm}$
Nozzle thickness	$t_{on} = 13.50 \text{ mm}$
Nozzle mill undertolerance	$C_{n1} = 1.70 \text{ mm}$
Nozzle forging undertolerance	$C_{n2} = 0.00 \text{ mm}$
Corrosion allowance	$c = 3.00 \text{ mm}$
Inside radius of obround cross section	$R_i = 43.50 \text{ mm}$
Length of the side plate of obround cross section	$L = 87.00 \text{ mm}$
Distance from loads application to circular cross section	$a = 7.60 \text{ mm}$
Distance from loads application to obround cross section	$b = 200.00 \text{ mm}$

APPLIED LOADS

Force in X direction	$F_x = 10020 \text{ N}$
Force in Y direction	$F_y = 8010 \text{ N}$
Force in Z direction	$F_z = 10020 \text{ N}$
Moment in X direction	$M_x = 2430 \text{ m.N}$
Moment in Y direction	$M_y = 3660 \text{ m.N}$
Moment in Z direction	$M_z = 2430 \text{ m.N}$

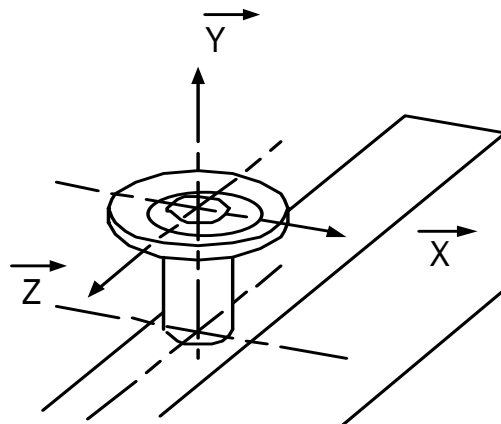

 <p>Damafin Thermal Technology Co.</p>	<p>JOB N°: 1158</p> <p>ITEM : A</p>	<p>Rev 00</p>	<p>Date 01.JUN.202S</p>	<p>Issued by S.SOLGI</p>	<p>Approved by A.GHOLIZADEH</p>
---	---	-------------------	-----------------------------	------------------------------	-------------------------------------

VESSEL UNDER INTERNAL PRESSURE

PAGE 14

CORRODED SIZES FOR CIRCULAR CROSS SECTION

$$t_{n1} = t_{on} - C - C_{n1} = 8.80 \text{ mm} \quad R_{o1} = d_o / 2 = 57.00 \text{ mm}$$

$$R_{i1} = R_{o1} - t_{n1} = 48.20 \text{ mm} \quad R_{m1} = R_{o1} - t_{n1} / 2 = 52.60 \text{ mm}$$

$$\text{Cross section area} \quad S_1 = 2908.36 \text{ mm}^2$$

$$\text{Mean cross section area} \quad A_1 = 8692.03 \text{ mm}^2$$

$$\text{Moment of inertia} \quad I_{x1} = 4051521 \text{ mm}^4$$

$$\text{Moment of inertia} \quad I_{z1} = 4051521 \text{ mm}^4$$

CORRODED SIZES FOR OBOURD CROSS SECTION

$$t_{n2} = t_{on} - C - C_{n1} - C_{n2} = 8.80 \text{ mm} \quad R_{i2} = R_i + c = 46.50 \text{ mm}$$

$$R_{o2} = R_{i2} + t_{n2} = 55.30 \text{ mm} \quad R_{m2} = R_{i2} + t_{n2} / 2 = 50.90 \text{ mm}$$

$$\text{Cross section area} \quad S_2 = 4345.56 \text{ mm}^2$$

$$\text{Mean cross section area} \quad A_2 = 16995.87 \text{ mm}^2$$

$$\text{Moment of inertia} \quad I_{x2} = 17918129 \text{ mm}^4$$

$$\text{Moment of inertia} \quad I_{z2} = 7649914 \text{ mm}^4$$

CALCULATED STRESSES IN CIRCULAR CROSS SECTION

$$\text{Maximum principal stresses} \quad \sigma_1 = 29.6 \text{ Mpa} \quad \sigma_2 = 0.0 \text{ Mpa} \quad \sigma_3 = -55.5 \text{ Mpa}$$

Stress intensity

$$S_{12} = |\sigma_1 - \sigma_2| = 29.6 \text{ Mpa} \quad S_{23} = |\sigma_2 - \sigma_3| = 55.5 \text{ Mpa} \quad S_{31} = |\sigma_3 - \sigma_1| = 85.1 \text{ Mpa}$$

$$\text{Maximum stress intensity} \quad S = \max (S_{12} , S_{23} , S_{31}) \quad S = 85.1 \text{ Mpa}$$

$$S < 1.5 \cdot S_n \quad \text{Design OK}$$

CALCULATED STRESSES IN OBOURD CROSS SECTION

$$\text{Maximum principal stresses} \quad \sigma_1 = 30.1 \text{ Mpa} \quad \sigma_2 = 0.0 \text{ Mpa} \quad \sigma_3 = -23.4 \text{ Mpa}$$

Stress intensity

$$S_{12} = |\sigma_1 - \sigma_2| = 30.1 \text{ Mpa} \quad S_{23} = |\sigma_2 - \sigma_3| = 23.4 \text{ Mpa} \quad S_{31} = |\sigma_3 - \sigma_1| = 53.6 \text{ Mpa}$$

$$\text{Maximum stress intensity} \quad S = \max (S_{12} , S_{23} , S_{31}) \quad S = 53.6 \text{ Mpa}$$

$$S < 1.5 \cdot S_n \quad \text{Design OK}$$

VESSEL UNDER INTERNAL PRESSURE

EXTERNAL LOADS ON NOZZLE

Code ASME VIII Div. 1 Ed. 2017

OUTLET 2",LWN,SCH160,#300

U-2(g)

DESIGN CONDITIONS

Internal design pressure	$P = 2.200 \text{ Mpa}$
Design temperature	$\theta = 120.0 \text{ }^\circ\text{C}$
Nozzle Material SA 350 LF2 CLASS1	
Maximum allowable stress value	$S_n = 138.0 \text{ Mpa}$
Nozzle outside diameter	$d_o = 82.50 \text{ mm}$
Nozzle thickness	$t_{on} = 15.85 \text{ mm}$
Nozzle mill undertolerance	$C_{n1} = 0.00 \text{ mm}$
Nozzle forging undertolerance	$C_{n2} = 0.00 \text{ mm}$
Corrosion allowance	$c = 3.00 \text{ mm}$
Inside radius of obround cross section	$R_i = 25.40 \text{ mm}$
Length of the side plate of obround cross section	$L = 50.80 \text{ mm}$
Distance from loads application to circular cross section	$a = 19.10 \text{ mm}$
Distance from loads application to obround cross section	$b = 200.00 \text{ mm}$

APPLIED LOADS

Force in X direction	$F_x = 3060 \text{ N}$
Force in Y direction	$F_y = 3990 \text{ N}$
Force in Z direction	$F_z = 3060 \text{ N}$
Moment in X direction	$M_x = 450 \text{ m.N}$
Moment in Y direction	$M_y = 720 \text{ m.N}$
Moment in Z direction	$M_z = 450 \text{ m.N}$

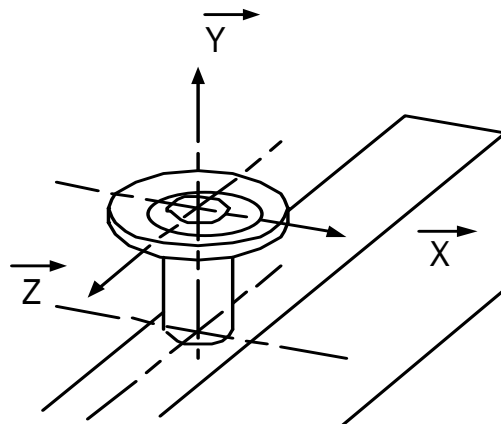

 <p>Damafin Thermal Technology Co.</p>	<p>JOB N°: 1158</p> <p>ITEM : A</p>	<p>Rev 00</p>	<p>Date 01.JUN.202S</p>	<p>Issued by S.SOLGI</p>	<p>Approved by A.GHOLIZADEH</p>
---	---	-------------------	-----------------------------	------------------------------	-------------------------------------

VESSEL UNDER INTERNAL PRESSURE

PAGE 16

CORRODED SIZES FOR CIRCULAR CROSS SECTION

$$t_{n1} = t_{on} - C - C_{n1} = 12.85 \text{ mm} \quad R_{o1} = d_o / 2 = 41.25 \text{ mm}$$

$$R_{i1} = R_{o1} - t_{n1} = 28.40 \text{ mm} \quad R_{m1} = R_{o1} - t_{n1} / 2 = 34.83 \text{ mm}$$

$$\text{Cross section area} \quad S_1 = 2811.73 \text{ mm}^2$$

$$\text{Mean cross section area} \quad A_1 = 3810.06 \text{ mm}^2$$

$$\text{Moment of inertia} \quad I_{x1} = 1763043 \text{ mm}^4$$

$$\text{Moment of inertia} \quad I_{z1} = 1763043 \text{ mm}^4$$

CORRODED SIZES FOR OBOURD CROSS SECTION

$$t_{n2} = t_{on} - C - C_{n1} - C_{n2} = 12.85 \text{ mm} \quad R_{i2} = R_i + c = 28.40 \text{ mm}$$

$$R_{o2} = R_{i2} + t_{n2} = 41.25 \text{ mm} \quad R_{m2} = R_{i2} + t_{n2} / 2 = 34.83 \text{ mm}$$

$$\text{Cross section area} \quad S_2 = 4117.29 \text{ mm}^2$$

$$\text{Mean cross section area} \quad A_2 = 7348.28 \text{ mm}^2$$

$$\text{Moment of inertia} \quad I_{x2} = 7060471 \text{ mm}^4$$

$$\text{Moment of inertia} \quad I_{z2} = 3364366 \text{ mm}^4$$

CALCULATED STRESSES IN CIRCULAR CROSS SECTION

$$\text{Maximum principal stresses} \quad \sigma_1 = 10.9 \text{ Mpa} \quad \sigma_2 = 0.0 \text{ Mpa} \quad \sigma_3 = -15.6 \text{ Mpa}$$

$$\text{Stress intensity}$$

$$S_{12} = |\sigma_1 - \sigma_2| = 10.9 \text{ Mpa} \quad S_{23} = |\sigma_2 - \sigma_3| = 15.6 \text{ Mpa} \quad S_{31} = |\sigma_3 - \sigma_1| = 26.5 \text{ Mpa}$$

$$\text{Maximum stress intensity} \quad S = \max (S_{12} , S_{23} , S_{31}) \quad S = 26.5 \text{ Mpa}$$

$$S < 1.5 \cdot S_n \quad \text{Design OK}$$

CALCULATED STRESSES IN OBOURD CROSS SECTION

$$\text{Maximum principal stresses} \quad \sigma_1 = 11.1 \text{ Mpa} \quad \sigma_2 = 0.0 \text{ Mpa} \quad \sigma_3 = -8.1 \text{ Mpa}$$

$$\text{Stress intensity}$$

$$S_{12} = |\sigma_1 - \sigma_2| = 11.1 \text{ Mpa} \quad S_{23} = |\sigma_2 - \sigma_3| = 8.1 \text{ Mpa} \quad S_{31} = |\sigma_3 - \sigma_1| = 19.2 \text{ Mpa}$$

$$\text{Maximum stress intensity} \quad S = \max (S_{12} , S_{23} , S_{31}) \quad S = 19.2 \text{ Mpa}$$

$$S < 1.5 \cdot S_n \quad \text{Design OK}$$

FileName : 1158

Rectves Analysis : FRONT

Item: 1 9:05a Jun 1,2024

Input Echo, COMPONENT 1, Description: FRONT

Figure Number Analyzed A8

Design Internal Pressure P 22.0000 bars
 Design Temperature Temp 120.0000 C

VESSEL MATERIAL DATA:
 Material Specification SA-516 70
 Shell Allowable Stress at Design Temp S 137.9000 N./mm^2
 Shell Allowable Stress at Ambient SA 137.9000 N./mm^2
 Shell Yield Stress at Design Temperature Sy 235.9761 N./mm^2

SHORT-SIDE VESSEL DATA:
 Short-side Length Dimension H 100.0000 mm.
 Minimum Thickness of Short-side Plates t1 20.0000 mm.
 Mid-side Joint Efficiency on Short-side E 0.8500
 Corner Joint Efficiency on Short-side EC 0.8500

LONG-SIDE VESSEL DATA:
 Long-side Length Dimension h 140.0000 mm.
 Minimum Thickness of Long-side Plates t2 20.0000 mm.
 Mid-side Joint Efficiency on Long-side E 0.8500

ADDITIONAL VESSEL DATA:
 Minimum Thickness of End Plate t5 20.0000 mm.
 C-Factor for End Plate Cf_Epl 0.2000
 Corrosion Allowance of Shell CA 3.0000 mm.

Long-side Plate # 1,
 Pitch Distance p 69.8500 mm.
 # 1: Hole Diameter d0 35.5000 mm.
 Hole Depth T0 1.7000 mm.
 # 2: Hole Diameter d1 25.7000 mm.
 Hole Depth T1 18.3000 mm.

Long-side Plate # 2,
 Pitch Distance p 69.8500 mm.
 Uniform Hole Diameter d0 25.7000 mm.
 Depth of Holes T0 20.0000 mm.

STAY PLATE MATERIAL DATA:
 Stay Material Specification SA-516 70
 Stay Allowable Stress at Design Temp Sr 137.9000 N./mm^2
 Stay Allowable Stress at Ambient SA 137.9000 N./mm^2
 Stay Yield Stress at Design Temp Sy 262.0100 N./mm^2

STAY PLATE DATA:
 Minimum Thickness of Stay t3 12.0000 mm.
 Minimum Thickness of Stay t4 12.0000 mm.
 The Stay(s) Are Not Welded to the End Plate
 Corrosion Allowance of Stay CAS 3.0000 mm.

Rectangular Vessel Results, Item number 1, Desc: FRONT
ASME Code, Section VIII, Division 1, 2017 App. 13

Ligament Efficiency Calculations (Section 13-6, Equations (1)-(6)):

Short-side 1 Calculations

Membrane Ligament Efficiency [Em]:
 = 0.850

Bending Ligament Efficiency [Eb]:
 = 0.850

Dist from Neutral axis of c/s to inside surface of the vessel [Ci]:
 = t1 - CA / 2
 = 20.000 - 3.000 / 2
 = 8.500 mm.

FileName : 1158

Rectves Analysis : FRONT

Item: 1 9:05a Jun 1,2024

Dist from Neutral axis of c/s to extreme outside surface of the section [Co]:

$$\begin{aligned}
 &= -(t_1 - CA) / 2 \\
 &= -(20.000 - 3.000) / 2 \\
 &= -8.500 \text{ mm.}
 \end{aligned}$$

Short-side 2 Calculations

Membrane Ligament Efficiency [Em]:

$$= 0.850$$

Bending Ligament Efficiency [Eb]:

$$= 0.850$$

Dist from Neutral axis of c/s to inside surface of the vessel [Ci]:

$$\begin{aligned}
 &= t_1 - CA / 2 \\
 &= 20.000 - 3.000 / 2 \\
 &= 8.500 \text{ mm.}
 \end{aligned}$$

Dist from Neutral axis of c/s to extreme outside surface of the section [Co]:

$$\begin{aligned}
 &= -(t_1 - CA) / 2 \\
 &= -(20.000 - 3.000) / 2 \\
 &= -8.500 \text{ mm.}
 \end{aligned}$$

Long-side 1 Calculations

Effective Diameter [De]:

$$\begin{aligned}
 &= (d_0 * T_0 + d_1 * T_1 + d_2 * T_2) / (t_1 - CA) \\
 &= (35.50 * 1.70 + 25.70 * 15.30 + 0.00 * 0.00) / \\
 &\quad (20.00 - 3.00) \\
 &= 26.680 \text{ mm.}
 \end{aligned}$$

Membrane Ligament Efficiency [Em]:

$$\begin{aligned}
 &= \text{Pitch} - De / \text{Pitch} \\
 &= 69.850 - 26.680 / 69.850 \\
 &= 0.618
 \end{aligned}$$

Dist from Neutral axis of c/s to extreme fibers [Ci & Co]:

Calculation of Xbar:

$$\begin{aligned}
 &= ((b_0 * T_0 * (T_0/2 + T_1 + T_2)) + (b_1 * T_1 * \\
 &\quad (T_1/2 + T_2)) + (b_2 * T_2 * (T_2/2))) / \\
 &\quad (b_0 * T_0 + b_1 * T_1 + b_2 * T_2) \\
 &= ((1.35 * 1.70 * (1.70/2 + 15.30 + 0.00)) + (1.74 * 15.30 * \\
 &\quad (15.30/2 + 0.00)) + (2.75 * 0.00 * (0.00/2))) / \\
 &\quad (1.35 * 1.70 + 1.74 * 15.30 + 2.75 * 0.00) \\
 &= 8.326 \text{ mm.}
 \end{aligned}$$

Dist from Neutral axis of c/s to inside surface of the vessel [Ci]:

Ci = Xbar

$$= 8.326 \text{ mm.}$$

Dist from Neutral axis of c/s to extreme outside surface of the section [Co]:

$$\begin{aligned}
 &= -(t - CA - Xbar) \\
 &= -(20.000 - 3.000 - 8.326) \\
 &= -8.674 \text{ mm.}
 \end{aligned}$$

Moment of Inertia (Section 13-6, Equation (5)) [I]:

$$= 0.067 \text{ cm}^4$$

Effective Diameter [De]:

$$\begin{aligned}
 &= \text{Pitch} - ((6 * I) / ((t - CA)^2 * (-Co))) \\
 &= 69.85 - ((6 * 0.07) / ((20.00 - 3.00)^2 * (8.67))) \\
 &= 28.980 \text{ mm.}
 \end{aligned}$$

Bending Ligament Efficiency [Eb]:

$$\begin{aligned}
 &= \text{Pitch} - De / \text{Pitch} \\
 &= 69.850 - 28.980 / 69.850 \\
 &= 0.585
 \end{aligned}$$

FileName : 1158 -----

Rectves Analysis : FRONT

Item: 1 9:05a Jun 1,2024

Long-side 2 Calculations

Effective Diameter [De]: 25.700 mm.

Membrane Ligament Efficiency [Em]:

$$= \text{Pitch} - \text{De} / \text{Pitch}$$

$$= 69.850 - 25.700 / 69.850$$

$$= 0.632$$

Bending Ligament Efficiency [Eb]:

As diameter holes are uniform $E_b = E_m$

$$= 0.632$$

Dist from Neutral axis of c/s to inside surface of the vesssel [Ci]:

$$= t1 - \text{CA} / 2$$

$$= 20.000 - 3.000 / 2$$

$$= 8.500 \text{ mm.}$$

Dist from Neutral axis of c/s to extreme outside surface of the section [Co]:

$$= - (t1 - \text{CA}) / 2$$

$$= - (20.000 - 3.000) / 2$$

$$= -8.500 \text{ mm.}$$

Ligament Efficiency Calculations (Section 13-6, Equations (1)-(6)):

	Em	Eb	Ci	Co
Short-side 1	0.850	0.850	8.500	-8.500
2	0.850	0.850	8.500	-8.500
Long-side 1	0.618	0.585	8.326	-8.674
2	0.632	0.632	8.500	-8.500

Moment of Inertia of a Strip of the Vessel Wall:

Thickness t1, I1 = 0.0409 cm**4

Thickness t2, I2 = 0.0409 cm**4

Rectangular Vessel Parameters:

$$\text{Alpha} = \text{H} / \text{h} = 0.7260$$

$$\text{K} = (\text{I2}/\text{I1}) * \text{Alpha} = 0.7260$$

Membrane Stress Calculations per Section 13-9

Membrane Stresses at Short-side 1

Membrane Stress at Short-side 1 [Sms]:

$$= P * h / (2 * t1) * \{ 3 - [(6 + K * (11 - \text{alpha}^2) / (3 + 5 * K))] \}$$

$$= 22.00 * 146.00 / (2 * 17.00) * \{ 3 - [(6 + 0.73 * (11 - 0.73^2) / (3 + 5 * 0.73))] \}$$

$$= 8.96 \text{ N./mm}^2$$

Membrane Stresses at Short-side 2

Membrane Stress at Short-side 2 [Sms]:

$$= P * h / (2 * t1) * \{ 3 - [(6 + K * (11 - \text{alpha}^2) / (3 + 5 * K))] \}$$

$$= 22.00 * 146.00 / (2 * 17.00) * \{ 3 - [(6 + 0.73 * (11 - 0.73^2) / (3 + 5 * 0.73))] \}$$

$$= 8.96 \text{ N./mm}^2$$

Membrane Stresses at Long-side 1

Membrane Stress at Long-side 1 at A [Sml]:

$$= P * H / 2 * t2$$

$$= 22.00 * 106.00 / 2 * 17.00$$

$$= 6.86 \text{ N./mm}^2$$

If $E_m(0.618) < E(0.850)$ and $E_b(0.585) < E(0.850)$ then

$$\text{Sml} = \text{Sml} / E_m$$

$$= 6.86 / 0.62$$

FileName : 1158 -----

Rectves Analysis : FRONT

Item: 1 9:05a Jun 1,2024

$$= 11.10 \text{ N./mm}^2$$

Membrane Stresses at Long-side 2

Membrane Stress at Long-side 2 at A [Sml]:

$$= P * H / 2 * t^2$$

$$= 22.00 * 106.00 / 2 * 17.00$$

$$= 6.86 \text{ N./mm}^2$$

If $E_m(0.632) < E(0.850)$ and $E_b(0.632) < E(0.850)$ then

$$S_{ml} = S_{ml} / E_m$$

$$= 6.86 / 0.63$$

$$= 10.85 \text{ N./mm}^2$$

Membrane Stresses at Stay Plate

Membrane Stress at Stay Plate [t3]:

$$= P * h / (2 * t^3) * [(6 + K * (11 - \alpha^2) / (3 + 5 * K))]$$

$$= 22.00 * 146.00 / (2 * 6.00) * [(6 + 0.73 * (11 - 0.73^2) / (3 + 5 * 0.73))]$$

$$= 54.92 \text{ N./mm}^2$$

Membrane Stress at Stay Plate [t4]:

$$= P * h / (2 * t^4) * [(6 + K * (11 - \alpha^2) / (3 + 5 * K))]$$

$$= 22.00 * 146.00 / (2 * 6.00) * [(6 + 0.73 * (11 - 0.73^2) / (3 + 5 * 0.73))]$$

$$= 54.92 \text{ N./mm}^2$$

MEMBRANE STRESSES: Membrane Stress Calculations per Section 13-9, Equations (13-15). (N./mm²) :

STRESS LOCATIONS	Actual	Allowable
Short-side 1	8.96	117.22
Short-side 2	8.96	117.22
Short-side Corner	8.96	117.22
Long-side 1 at A	11.10	137.90
Long-side 2 at A	10.85	137.90
Long-side Corner	6.86	117.22
Stay Plate (t3)	54.92	137.90
Stay Plate (t4)	54.92	137.90

Bending Stress Calculations per Section 13-9

Bending Stresses at Short-side 1

Bending Stress at Short-side 1 at N Inner[SbsNi]:

$$= P * c / (24 * I_1) * [-3 * H^2 + 2 * h^2 * ((3 + 5 * \alpha^2 * K) / (3 + 5 * K))]$$

$$= 22.00 * 8.50 / (24 * 0.04) * [-3 * 106.00^2 + 2 * 146.00^2 * ((3 + 5 * 0.73^2 * 0.73) / (3 + 5 * 0.73))]$$

$$= -4.02 \text{ N./mm}^2$$

Bending Stress at Short-side 1 at N Outer[SbsNo]:

$$= P * c / (24 * I_1) * [-3 * H^2 + 2 * h^2 * ((3 + 5 * \alpha^2 * K) / (3 + 5 * K))]$$

$$= 22.00 * -8.50 / (24 * 0.04) * [-3 * 106.00^2 + 2 * 146.00^2 * ((3 + 5 * 0.73^2 * 0.73) / (3 + 5 * 0.73))]$$

$$= 4.02 \text{ N./mm}^2$$

Bending Stress at Short-side 1 at Q Inner[SbsQi]:

$$= P * h^2 * c / (12 * I_1) * ((3 + 5 * \alpha^2 * K) / (3 + 5 * K))$$

$$= 22.00 * 146.00^2 * 8.50 / (12 * 0.04) * ((3 + 5 * 0.73^2 * 0.73) / (3 + 5 * 0.73))$$

$$= 60.13 \text{ N./mm}^2$$

Bending Stress at Short-side 1 at Q Outer[SbsQo]:

$$= P * h^2 * c / (12 * I_1) * ((3 + 5 * \alpha^2 * K) / (3 + 5 * K))$$

FileName : 1158

Rectves Analysis : FRONT

Item: 1 9:05a Jun 1,2024

$$= 22.00 * 146.00^2 * -8.50 / (12 * 0.04) * ((3 + 5 * 0.73^2 * 0.73) / (3 + 5 * 0.73))$$

$$= -60.13 \text{ N./mm}^2$$

Bending Stresses at Short-side 2

Bending Stress at Short-side 2 at N Inner[SbsNi]:

$$= P * c / (24 * I1) * [-3 * H^2 + 2 * h^2 * ((3 + 5 * Alpha^2 * K) / (3 + 5 * K))]$$

$$= 22.00 * 8.50 / (24 * 0.04) * [-3 * 106.00^2 + 2 * 146.00^2 * ((3 + 5 * 0.73^2 * 0.73) / (3 + 5 * 0.73))]$$

$$= -4.02 \text{ N./mm}^2$$

Bending Stress at Short-side 2 at N Outer[SbsNo]:

$$= P * c / (24 * I1) * [-3 * H^2 + 2 * h^2 * ((3 + 5 * Alpha^2 * K) / (3 + 5 * K))]$$

$$= 22.00 * -8.50 / (24 * 0.04) * [-3 * 106.00^2 + 2 * 146.00^2 * ((3 + 5 * 0.73^2 * 0.73) / (3 + 5 * 0.73))]$$

$$= 4.02 \text{ N./mm}^2$$

Bending Stress at Short-side 2 at Q Inner[SbsQi]:

$$= P * h^2 * c / (12 * I1) * ((3 + 5 * Alpha^2 * K) / (3 + 5 * K))$$

$$= 22.00 * 146.00^2 * 8.50 / (12 * 0.04) * ((3 + 5 * 0.73^2 * 0.73) / (3 + 5 * 0.73))$$

$$= 60.13 \text{ N./mm}^2$$

Bending Stress at Short-side 2 at Q Outer[SbsQo]:

$$= P * h^2 * c / (12 * I1) * ((3 + 5 * Alpha^2 * K) / (3 + 5 * K))$$

$$= 22.00 * 146.00^2 * -8.50 / (12 * 0.04) * ((3 + 5 * 0.73^2 * 0.73) / (3 + 5 * 0.73))$$

$$= -60.13 \text{ N./mm}^2$$

Bending Stresses at Long-side 1

Bending Stress at Long-side 1 at M Inner[SblMi]:

$$= P * h^2 * c / (12 * I2) * [(3 + K * (6 - Alpha^2)) / (3 + 5 * K)]$$

$$= 22.00 * 146.00^2 * 8.33 / (12 * 0.04) * [(3 + 0.73 * (6 - 0.73^2)) / (3 + 5 * 0.73)]$$

$$= 83.60 \text{ N./mm}^2$$

If $E_m(0.618) < E(0.850)$ and $E_b(0.585) < E(0.850)$ then

$$SblMi = SblMi / Eb$$

$$= 83.60 / 0.59$$

$$= 142.87 \text{ N./mm}^2$$

Bending Stress at Long-side 1 at M Outer[SblMo]:

$$= P * h^2 * c / (12 * I2) * [(3 + K * (6 - Alpha^2)) / (3 + 5 * K)]$$

$$= 22.00 * 146.00^2 * -8.67 / (12 * 0.04) * [(3 + 0.73 * (6 - 0.73^2)) / (3 + 5 * 0.73)]$$

$$= -87.08 \text{ N./mm}^2$$

If $E_m(0.618) < E(0.850)$ and $E_b(0.585) < E(0.850)$ then

$$SblMo = SblMo / Eb$$

$$= -87.08 / 0.59$$

$$= -148.83 \text{ N./mm}^2$$

Bending Stress at Long-side 1 at Q Inner[SblQi]:

$$= P * h^2 * c / (12 * I2) * [(3 + 5 * Alpha^2 * K) / (3 + 5 * K)]$$

$$= 22.00 * 146.00^2 * 8.33 / (12 * 0.04) * [(3 + 5 * 0.73^2 * 0.73) / (3 + 5 * 0.73)]$$

$$= 58.90 \text{ N./mm}^2$$

Bending Stress at Long-side 1 at Q Outer[SblQo]:

$$= P * h^2 * c / (12 * I2) * [(3 + 5 * Alpha^2 * K) / (3 + 5 * K)]$$

FileName : 1158

Rectves Analysis : FRONT

Item: 1 9:05a Jun 1,2024

$$= 22.00 * 146.00^2 * -8.67 / (12 * 0.04) * [(3 + 5 * 0.73^2 * 0.73) / (3 + 5 * 0.73)]$$

$$= -61.36 \text{ N./mm}^2$$

Bending Stresses at Long-side 2

Bending Stress at Long-side 2 at M Inner[SblMi]:

$$= P * h^2 * c / (12 * I2) * [(3 + K * (6 - Alpha^2)) / (3 + 5 * K)]$$

$$= 22.00 * 146.00^2 * 8.50 / (12 * 0.04) * [(3 + 0.73 * (6 - 0.73^2)) / (3 + 5 * 0.73)]$$

$$= 85.34 \text{ N./mm}^2$$

If $E_m(0.632) < E(0.850)$ and $E_b(0.632) < E(0.850)$ then

$$SblMi = SblMi / Eb$$

$$= 85.34 / 0.63$$

$$= 135.02 \text{ N./mm}^2$$

Bending Stress at Long-side 2 at M Outer[SblMo]:

$$= P * h^2 * c / (12 * I2) * [(3 + K * (6 - Alpha^2)) / (3 + 5 * K)]$$

$$= 22.00 * 146.00^2 * -8.50 / (12 * 0.04) * [(3 + 0.73 * (6 - 0.73^2)) / (3 + 5 * 0.73)]$$

$$= -85.34 \text{ N./mm}^2$$

If $E_m(0.632) < E(0.850)$ and $E_b(0.632) < E(0.850)$ then

$$SblMo = SblMo / Eb$$

$$= -85.34 / 0.63$$

$$= -135.02 \text{ N./mm}^2$$

Bending Stress at Long-side 2 at Q Inner[SblQi]:

$$= P * h^2 * c / (12 * I2) * [(3 + 5 * Alpha^2 * K) / (3 + 5 * K)]$$

$$= 22.00 * 146.00^2 * 8.50 / (12 * 0.04) * [(3 + 5 * 0.73^2 * 0.73) / (3 + 5 * 0.73)]$$

$$= 60.13 \text{ N./mm}^2$$

Bending Stress at Long-side 2 at Q Outer[SblQo]:

$$= P * h^2 * c / (12 * I2) * [(3 + 5 * Alpha^2 * K) / (3 + 5 * K)]$$

$$= 22.00 * 146.00^2 * -8.50 / (12 * 0.04) * [(3 + 5 * 0.73^2 * 0.73) / (3 + 5 * 0.73)]$$

$$= -60.13 \text{ N./mm}^2$$

BENDING STRESSES: Bending Stress Calculations per Section 13-9, Equations (16-19). (N./mm²) :

STRESS LOCATIONS	Inner	Outer	Allowable
Short-side 1 at N	-4.02	4.02	175.82
at Q	60.13	-60.13	175.82
Short-side 2 at N	-4.02	4.02	175.82
at Q	60.13	-60.13	175.82
Long-side 1 at M	142.87	-148.83	206.85
at Q	58.90	-61.36	175.82
Long-side 2 at M	135.02	-135.02	206.85
at Q	60.13	-60.13	175.82

Total Stress Calculations per Section 13-9

Total Stresses at Short-side 1

Total Stress at short side 1 at N inner [STS_Ni]:

$$= Sms + SbsNi$$

$$= 8.96 + -4.02$$

$$= 4.93 \text{ N./mm}^2$$

Total Stress at short side 1 at N outer [STS_No]:

$$= Sms + SbsNo$$

$$= 8.96 + 4.02$$

$$= 12.98 \text{ N./mm}^2$$

FileName : 1158

Rectves Analysis : FRONT

Item: 1 9:05a Jun 1,2024

Total Stress at short side 1 at Q inner [STS_Qi]:

$$\begin{aligned} &= S_{ms} + S_{bsQi} \\ &= 8.96 + 60.13 \\ &= 69.09 \text{ N./mm}^2 \end{aligned}$$

Total Stress at short side 1 at Q outer [STS_Qo]:

$$\begin{aligned} &= S_{ms} + S_{bsQo} \\ &= 8.96 + -60.13 \\ &= -51.17 \text{ N./mm}^2 \end{aligned}$$

Total Stresses at Short-side 2

Total Stress at short side 2 at N inner [STS_Ni]:

$$\begin{aligned} &= S_{ms} + S_{bsNi} \\ &= 8.96 + -4.02 \\ &= 4.93 \text{ N./mm}^2 \end{aligned}$$

Total Stress at short side 2 at N outer [STS_No]:

$$\begin{aligned} &= S_{ms} + S_{bsNo} \\ &= 8.96 + 4.02 \\ &= 12.98 \text{ N./mm}^2 \end{aligned}$$

Total Stress at short side 2 at Q inner [STS_Qi]:

$$\begin{aligned} &= S_{ms} + S_{bsQi} \\ &= 8.96 + 60.13 \\ &= 69.09 \text{ N./mm}^2 \end{aligned}$$

Total Stress at short side 2 at Q outer [STS_Qo]:

$$\begin{aligned} &= S_{ms} + S_{bsQo} \\ &= 8.96 + -60.13 \\ &= -51.17 \text{ N./mm}^2 \end{aligned}$$

Total Stresses at Long-side 1

Total Stress at long side 1 at M inner [STL_Mi]:

$$\begin{aligned} &= S_{m1} + S_{b1Mi} \\ &= 11.10 + 142.87 \\ &= 153.97 \text{ N./mm}^2 \end{aligned}$$

Total Stress at long side 1 at M outer [STL_Mo]:

$$\begin{aligned} &= S_{m1} + S_{b1Mo} \\ &= 11.10 + -148.83 \\ &= -137.73 \text{ N./mm}^2 \end{aligned}$$

Total Stress at long side 1 at Q inner [STL_Qi]:

$$\begin{aligned} &= S_{m1} + S_{b1Qi} \\ &= 6.86 + 58.90 \\ &= 65.76 \text{ N./mm}^2 \end{aligned}$$

Total Stress at long side 1 at Q outer [STL_Qo]:

$$\begin{aligned} &= S_{m1} + S_{b1Qo} \\ &= 6.86 + -61.36 \\ &= -54.50 \text{ N./mm}^2 \end{aligned}$$

Total Stresses at Long-side 2

Total Stress at long side 2 at M inner [STL_Mi]:

$$\begin{aligned} &= S_{m1} + S_{b1Mi} \\ &= 10.85 + 135.02 \\ &= 145.87 \text{ N./mm}^2 \end{aligned}$$

Total Stress at long side 2 at M outer [STL_Mo]:

$$\begin{aligned} &= S_{m1} + S_{b1Mo} \\ &= 10.85 + -135.02 \\ &= -124.16 \text{ N./mm}^2 \end{aligned}$$

Total Stress at long side 2 at Q inner [STL_Qi]:

$$\begin{aligned} &= S_{m1} + S_{b1Qi} \\ &= 6.86 + 60.13 \end{aligned}$$

FileName : 1158

Rectves Analysis : FRONT

Item: 1 9:05a Jun 1,2024

= 66.99 N./mm²

Total Stress at long side 2 at Q outer [STL_Qo]:

= SmlB + SblQo
 = 6.86 + -60.13
 = -53.27 N./mm²

TOTAL STRESSES: Total Stress Calculations per Section 13-9, Equations (20-24). (N./mm²) :

STRESS LOCATIONS	Inner	Outer	Allowable
Short-side 1 at N	4.93	12.98	175.82
at Q	69.09	-51.17	175.82
Short-side 2 at N	4.93	12.98	175.82
at Q	69.09	-51.17	175.82
Long-side 1 at M	153.97	-137.73	206.85
at Q	65.76	-54.50	175.82
Long-side 2 at M	145.87	-124.16	206.85
at Q	66.99	-53.27	175.82

END PLATE STRESSES (N./mm²) :

	Actual	Allowable
End Plate	42.77	137.90

SUMMARY OF RESULTS:

MEMBRANE STRESS SUMMARY,

High Stress (Highest % of Allowable)	54.92	N./mm ²
High Stress Percentage	39.83	%
M.A.W.P. for Membrane Stresses	55.24	bars

BENDING STRESS SUMMARY,

High Stress (Highest % of Allowable)	-148.83	N./mm ²
High Stress Percentage	71.95	%
M.A.W.P. for Bending Stresses	30.58	bars

TOTAL STRESS SUMMARY,

High Stress (Highest % of Allowable)	153.97	N./mm ²
High Stress Percentage	74.44	%
M.A.W.P. for Total Stresses	29.56	bars

Rectangular Vessel Results For Item 1 : A8

SUMMARY OF RESULTS:

MEMBRANE STRESS SUMMARY,

High Stress (Highest % of Allowable)	54.92	N./mm ²
High Stress Percentage	39.83	%
M.A.W.P. for Membrane Stresses	55.24	bars

BENDING STRESS SUMMARY,

High Stress (Highest % of Allowable)	-148.83	N./mm ²
High Stress Percentage	71.95	%
M.A.W.P. for Bending Stresses	30.58	bars

TOTAL STRESS SUMMARY,

High Stress (Highest % of Allowable)	153.97	N./mm ²
High Stress Percentage	74.44	%
M.A.W.P. for Total Stresses	29.56	bars

Tabular Results

Results were generated with the finite element program FE/Pipe®. Stress results are post-processed in accordance with the rules specified in ASME Section III and ASME Section VIII, Division 2.

Analysis Time Stamp: Sat Jun 01 10:34:40 2024.

- [Model Notes, Tube Results and API Check](#)
- [Load Case Report](#)
- [Solution Data](#)
- [ASME Code Stress Output Plots](#)
- [Stress Results - Notes](#)
- [ASME Overstressed Areas](#)
- [Highest Primary Stress Ratios](#)
- [Highest Secondary Stress Ratios](#)
- [Highest Fatigue Stress Ratios](#)
- [Graphical Results](#)

Model Notes, Tube Results and API Check
Model Notes, Tube Results and API Check

661PRO 2.0 - API 661 - Air-Cooled Heat Exchanger Nozzle Model

Input Echo:

Notes:

- The centerline of the header box is along the -Z axis.
- Only 1 Nozzle will be modeled at a time. The Nozzle Number Modeled can be seen below.

Nozzle Number Modeled : 1
Top or Bottom Nozzle : Top

Analysis Type : API 661 Evaluation

Nozzle Type : Straight
Flange Type : Weldneck

Header Box Dimensions:
Centerline on :Centerline on LEFT Side
Height : 389.000 mm.
Width : 140.000 mm.
Length : 2510.000 mm.

Outboard Thickness : 17.000 mm.
Tubesheet Side Thickness : 17.000 mm.
Top Plate Thickness : 17.000 mm.
Free End Plate Thickness : 17.000 mm.

Header Box Pressure : 2.200 MPa

Header Box Fixed at Centerline

Partition Plates:
Number of Partition Plates : 2

Partition Plate #1
Plate Elevation from Bottom : 149.000 mm.
Plate Thickness : 6.000 mm.

Partition Plate #2
Plate Elevation from Bottom : 301.000 mm.
Plate Thickness : 6.000 mm.

Nozzle Dimensions:
Distance to CenterLine : 1255.000 mm.
Nozzle Outside Diameter : 114.000 mm.
Nozzle Thickness : 8.800 mm.

Projection to Face of Flange : 200.000 mm.
 Flange Thickness Used : 21.706 mm.
 Flange ID : 136.069 mm.
 Flange Hub Length Used : 32.559 mm.

Weld Size and SCF : 0.000, 1.350

Engineering Details:

Operating Cycles : 7000
 Occasional Cycles : 0
 Ambient Temperature : 21.100 deg.
 Computation Type : Gauss Average

Material Properties

Nozzle:

Cold Allowable Stress : 117.900 MPa
 Hot Allowable Stress : 117.900 MPa
 Elastic Modulus : 0.203E+06 MPa
 Poissons Ratio : 0.300
 Material ID :1-Low Carbon Steels
 Density : 0.768E-04 N /cu. mm.

Header Box:

Cold Allowable Stress : 137.900 MPa
 Hot Allowable Stress : 137.900 MPa
 Elastic Modulus : 0.203E+06 MPa
 Poissons Ratio : 0.300
 Material ID :2-Low Alloy Steels
 Density : 0.768E-04 N /cu. mm.

Tubesheet was not modeled

API Loads Applied:

API Multiplier : 3.000

Forces [N]	Moments [mm.- N]					
	FX	FY	FZ	MX	MY	MZ
Weight	10020	8010	10020	2430000	3660000	2430000
Operating	10020	8010	10020	2430000	3660000	2430000

No Tube Results

[Table of Contents](#)

Load Case Report
 FE/Pipe Version 7.0 Jobname: setup2 \$P
 Released Jul 2014 10:31am JUN 1,2024

Load Case Report \$X

Inner and outer element temperatures are the same throughout the model. No thermal ratcheting calculations will be performed.

THE 2 LOAD CASES ANALYZED ARE:

1 SUSTAINED (Pr Only)

Sustained case run to satisfy local primary membrane and bending stress limits.

/----- Loads in Case 1
 Pressure Case 1

2 OPERATING (Fatigue Calc Performed)

Case run to compute the operating stresses used in

secondary, peak and range calculations as needed.

/----- Loads in Case 2
 Pressure Case 1
 Loads from (Operating)

[Table of Contents](#)

Solution Data
 FE/Pipe Version 7.0 Jobname: setup2 \$P
 Released Jul 2014 10:32am JUN 1,2024

Solution Data

Maximum Solution Row Size = 1728
 Number of Nodes = 12063
 Number of Elements = 4107
 Number of Solution Cases = 2

Summation of Loads per Case

Case #	FX	FY	FZ
1	0.	-44871.	-100663.
2	10020.	-20804.	-90643.

[Table of Contents](#)

ASME Code Stress Output Plots
 FE/Pipe Version 7.0 Jobname: setup2 \$P
 Released Jul 2014 10:34am JUN 1,2024

ASME Code Stress Output Plots \$X

- 1) $P_l < 1.5(k)Sm_h$ (SUS,Membrane) Case 1
- 2) $Q_b < 3(Sm_h)$ (SUS,Bending) Case 1
- 3) $S_1+S_2+S_3 < 4S$ (SUS, $S_1+S_2+S_3$) Case 1
- 4) $P_l+P_b+Q < 3(Sm_{avg})$ (OPE,Inside) Case 2
- 5) $P_l+P_b+Q < 3(Sm_{avg})$ (OPE,Outside) Case 2
- 6) $P_l+P_b+Q+F < S_a$ (EXP,Inside) Case 2
- 7) $P_l+P_b+Q+F < S_a$ (EXP,Outside) Case 2
- 8) Membrane < User (OPE,Membrane) Case 2
- 9) Bending < User (OPE,Bending) Case 2

[Table of Contents](#)

Stress Results - Notes
 FE/Pipe Version 7.0 Jobname: setup2 \$P
 Released Jul 2014 10:34am JUN 1,2024

Stress Results - Notes

- Results in this analysis were generated using the finite element solution method.

- Using pre 07 ASME Section VIII Division 2
- Assume free end displacements of attached pipe are secondary loads within limits of nozzle reinforcement.
- Use Stress Intensity (TRESKA).
- S1+S2+S3 evaluation omitted from operating stress. Include S1+S2+S3 evaluation in primary case evaluation. Assume bending stress not local primary for S1+S2+S3.
- Use local tensor values for averaged and not averaged stresses.
 - PRIMARY STRESSES are similar to the B31 code "sustained" stresses. Primary stresses contain the effects due to weight, pressure and other sustained loads. The primary limit for this stress is based on collapse of the local cross section or excessive local strain.
 - SECONDARY (PL+PB+Q) STRESS has no direct equal in a B31 code. This stress requirement is intended to insure that significant inelastic behavior only occurs for the first few loading cycles, and only over a fairly small region of the model. "Small" is on the order of the square root of Rt, where (R) is the radius of the header and (t) is the thickness of the header. Secondary stresses do not include the effect of peak stress concentration factors such as occur at fillets, welds or notches.
 - PEAK STRESSES are equivalent to the B31 code "expansion" stresses. In the peak stress report, the user will find the equivalent B31 allowable computed from: $f[1.25(Sc+Sh)]$.
 - The LOCAL STRESS calculations performed herein are in accordance with ASME VIII Div 2, Part 5, elastic calculations, and ASME Section III Subsection NB. These methods have been used extensively in the nuclear piping industry, and have been shown to be in consistent agreement with the B31 piping codes when the simplifying assumptions made in the B31 codes are employed.
 - The B31 Code Stress Calculations performed herein are in accordance with the method outlined in NUREG/CR-3243 and (ORNL/Sub/82-22252/1). This paper shows the relationship between the fatigue evaluation methods used in the B31 codes and the class 1,2 and 3 nuclear piping codes.
 - When the number of design cycles is less than 7000, (which is the default), the B31 user is cautioned against using a smaller number of design cycles to satisfy the intersection allowables unless he is sure that the material can easily undergo significant peak plastic deformation without crack propagation.
 - Thru-the-wall temperature effects may be important when the temperature difference is high. The stress resulting from the difference is independant of the thickness. Users should estimate and enter this difference if available.
 - Membrane stresses are the stresses averaged thru the wall of the component. Secondary and Peak stresses are those that are maximums at the outer fiber of the local cross section due primarily to plate or shell type bending at the nozzle or discontinuity.

[Table of Contents](#)

ASME Overstressed Areas
 FE/Pipe Version 7.0 Jobname: setup2 \$P
 Released Jul 2014 10:34am JUN 1,2024

ASME Overstressed Areas \$X

*** NO OVERSTRESSED NODES IN THIS MODEL ***

[Table of Contents](#)

Highest Primary Stress Ratios

FE/Pipe Version 7.0
Released Jul 2014

Jobname: setup2
10:34am JUN 1,2024

\$P

Highest Primary Stress Ratios

\$X

Circ Plate for Plate # 1

Qb	3 (Smh)	Primary Bending Load Case 1
57	414	Sect VIII Ref: 4-112(h) (2), Table 4-120.1,
MPa	MPa	Fig.4-130.1, 4-133
		Plot Reference:
13%		2) Qb < 3(Smh) (SUS,Bending) Case 1

Long Plate for Plate # 1

Qb	3 (Smh)	Primary Bending Load Case 1
41	414	Sect VIII Ref: 4-112(h) (2), Table 4-120.1,
MPa	MPa	Fig.4-130.1, 4-133
		Plot Reference:
9%		2) Qb < 3(Smh) (SUS,Bending) Case 1

Circ Plate for Plate # 2

Qb	3 (Smh)	Primary Bending Load Case 1
57	414	Sect VIII Ref: 4-112(h) (2), Table 4-120.1,
MPa	MPa	Fig.4-130.1, 4-133
		Plot Reference:
13%		2) Qb < 3(Smh) (SUS,Bending) Case 1

Circ Plate for Plate # 3

Pl	1.5(k) Smh	Primary Membrane Load Case 1
24	177	Sect VIII Ref: AD-140, 4-112(i), 4-133,
MPa	MPa	Fig. 4-130.1, Table 4-120.1
		Plot Reference:
13%		1) Pl < 1.5(k) Smh (SUS,Membrane) Case 1

Circ Plate for Plate # 4

Pl	1.5(k) Smh	Primary Membrane Load Case 1
15	177	Sect VIII Ref: AD-140, 4-112(i), 4-133,
MPa	MPa	Fig. 4-130.1, Table 4-120.1
		Plot Reference:
8%		1) Pl < 1.5(k) Smh (SUS,Membrane) Case 1

Long Plate for Plate # 4

Pl	1.5(k) Smh	Primary Membrane Load Case 1
4	177	Sect VIII Ref: AD-140, 4-112(i), 4-133,
MPa	MPa	Fig. 4-130.1, Table 4-120.1
		Plot Reference:
2%		1) Pl < 1.5(k) Smh (SUS,Membrane) Case 1

[Table of Contents](#)

Highest Secondary Stress Ratios

FE/Pipe Version 7.0
Released Jul 2014

Jobname: setup2
10:34am JUN 1,2024

\$P

Highest Secondary Stress Ratios

\$X

Circ Plate for Plate # 1

Pl+Pb+Q	3 (Smavg)	Primary+Secondary (Outer) Load Case 2
---------	-----------	---------------------------------------

93 MPa	414 MPa	Sect VIII Ref: 4-120(b) (4), 4-134, 4-136.6, Fig. 4-130.1 (Note 1) Plot Reference: 5) Pl+Pb+Q < 3 (Smavg) (OPE, Outside) Case 2
22%		
Long Plate for Plate # 1		
Pl+Pb+Q 154 MPa	3 (Smavg) 414 MPa	Primary+Secondary (Outer) Load Case 2 Sect VIII Ref: 4-120(b) (4), 4-134, 4-136.6, Fig. 4-130.1 (Note 1) Plot Reference: 5) Pl+Pb+Q < 3 (Smavg) (OPE, Outside) Case 2
37%		
Circ Plate for Plate # 2		
Pl+Pb+Q 103 MPa	3 (Smavg) 414 MPa	Primary+Secondary (Outer) Load Case 2 Sect VIII Ref: 4-120(b) (4), 4-134, 4-136.6, Fig. 4-130.1 (Note 1) Plot Reference: 5) Pl+Pb+Q < 3 (Smavg) (OPE, Outside) Case 2
24%		
Circ Plate for Plate # 3		
Pl+Pb+Q 252 MPa	3 (Smavg) 354 MPa	Primary+Secondary (Inner) Load Case 2 Sect VIII Ref: 4-120(b) (4), 4-134, 4-136.6, Fig. 4-130.1 (Note 1) Plot Reference: 4) Pl+Pb+Q < 3 (Smavg) (OPE, Inside) Case 2
71%		
Circ Plate for Plate # 4		
Pl+Pb+Q 163 MPa	3 (Smavg) 354 MPa	Primary+Secondary (Inner) Load Case 2 Sect VIII Ref: 4-120(b) (4), 4-134, 4-136.6, Fig. 4-130.1 (Note 1) Plot Reference: 4) Pl+Pb+Q < 3 (Smavg) (OPE, Inside) Case 2
46%		
Long Plate for Plate # 4		
Pl+Pb+Q 40 MPa	3 (Smavg) 354 MPa	Primary+Secondary (Outer) Load Case 2 Sect VIII Ref: 4-120(b) (4), 4-134, 4-136.6, Fig. 4-130.1 (Note 1) Plot Reference: 5) Pl+Pb+Q < 3 (Smavg) (OPE, Outside) Case 2
11%		

[Table of Contents](#)

Highest Fatigue Stress Ratios

FE/Pipe Version 7.0
Released Jul 2014

Jobname: setup2
10:34am JUN 1, 2024

\$P

Highest Fatigue Stress Ratios

\$X

Circ Plate for Plate # 1

Pl+Pb+Q+F 46 MPa	Sa 290 MPa	Primary+Secondary+Peak (Outer) Load Case 2 Stress Concentration Factor = 1.000 Strain Concentration Factor = 1.000 Cycles Allowed for this Stress = 1.0000E11 "B31" Fatigue Stress Allowable = 344.8 Markl Fatigue Stress Allowable = 287.5 WRC 474 Mean Cycles to Failure = 5,667,978. WRC 474 99% Probability Cycles = 1,316,723. WRC 474 95% Probability Cycles = 1,828,104. BS5500 Allowed Cycles (Curve F) = 866,038. Membrane-to-Bending Ratio = 0.428 Bending-to-PL+PB+Q Ratio = 0.700 Sect VIII Ref: 4-112(1) (2), Fig. 4-130.1, 4-135 Plot Reference: 7) Pl+Pb+Q+F < Sa (EXP, Outside) Case 2
16%		

Long Plate for Plate # 1

WRC 474 95% Probability Cycles = 12,833,602.
 BS5500 Allowed Cycles(Curve F) = 6,339,758.
 Membrane-to-Bending Ratio = 0.515
 Bending-to-PL+PB+Q Ratio = 0.660
 Sect VIII Ref: 4-112(1)(2), Fig.4-130.1,4-135
 Plot Reference:
 7) Pl+Pb+Q+F < Sa (EXP,Outside) Case 2

Circ Plate for Plate # 5

Pl+Pb+Q+F	Sa	Primary+Secondary+Peak (Inner) Load Case 2
35	290	Stress Concentration Factor = 1.000
MPa	MPa	Strain Concentration Factor = 1.000
		Cycles Allowed for this Stress = 1.0000E11
12%		"B31" Fatigue Stress Allowable = 0.0
		MarkI Fatigue Stress Allowable = 287.5
		WRC 474 Mean Cycles to Failure = 24,762,802.
		WRC 474 99% Probability Cycles = 5,752,618.
		WRC 474 95% Probability Cycles = 7,986,786.
		BS5500 Allowed Cycles(Curve F) = 1,950,751.
		Membrane-to-Bending Ratio = 2.775
		Bending-to-PL+PB+Q Ratio = 0.265
		Sect VIII Ref: 4-112(1)(2), Fig.4-130.1,4-135
		Plot Reference:
		6) Pl+Pb+Q+F < Sa (EXP,Inside) Case 2

[Table of Contents](#)

Finite Element Model

- [Finite Element Model](#)
- [1\) \$PI < 1.5\(k\)Smh\$ \(SUS Membrane\) Case 1](#)
- [2\) \$Qb < 3\(Smh\)\$ \(SUS Bending\) Case 1](#)
- [3\) \$S1+S2+S3 < 4S\$ \(SUS \$S1+S2+S3\$ \) Case 1](#)
- [4\) \$PI+Pb+Q < 3\(Smavg\)\$ \(OPE Inside\) Case 2](#)
- [5\) \$PI+Pb+Q < 3\(Smavg\)\$ \(OPE Outside\) Case 2](#)
- [6\) \$PI+Pb+Q+F < Sa\$ \(EXP Inside\) Case 2](#)
- [7\) \$PI+Pb+Q+F < Sa\$ \(EXP Outside\) Case 2](#)
- [8\) Membrane < User \(OPE Membrane\) Case 2](#)
- [9\) Bending < User \(OPE Bending\) Case 2](#)

Finite Element Model

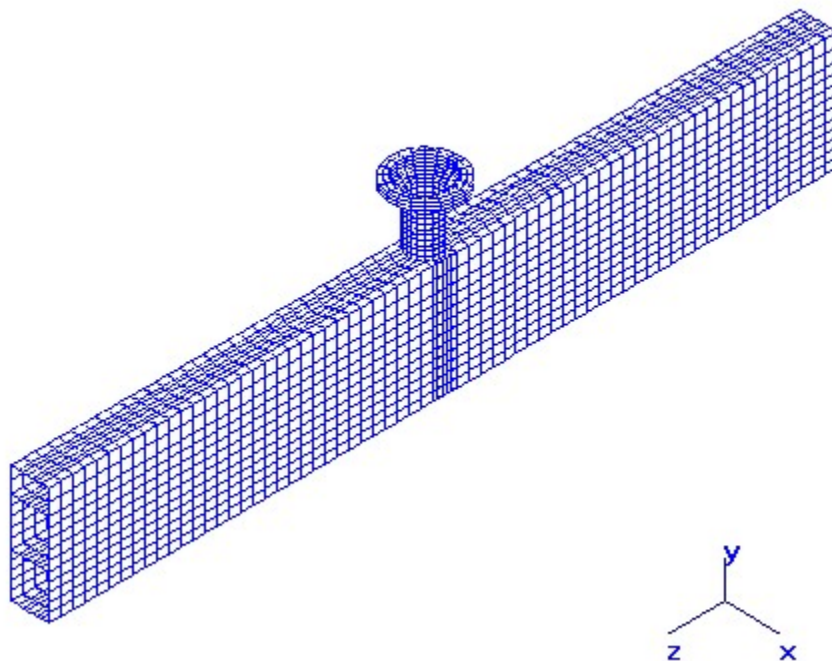

3d

1) P1 < 1.5(k)Smh (SUS_Membrane)_Case 1

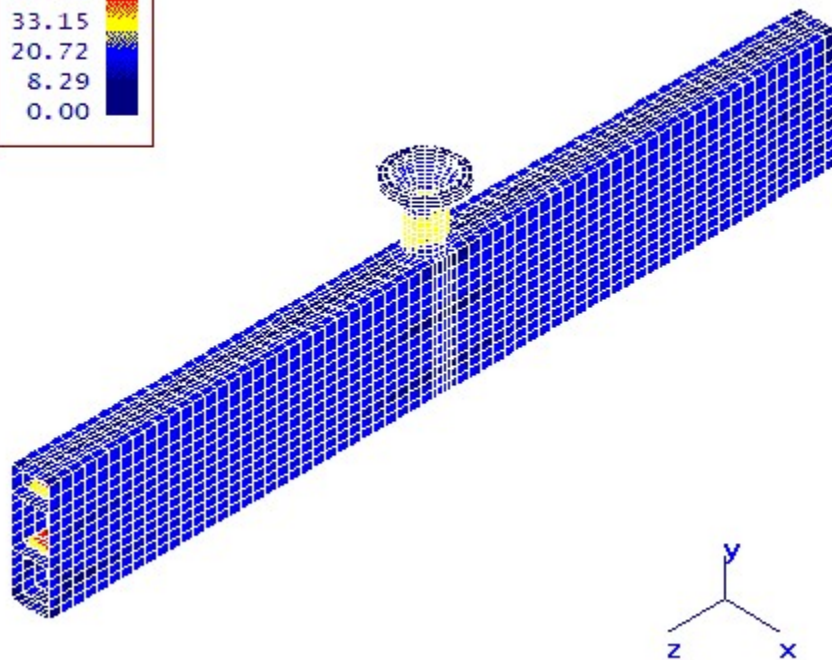
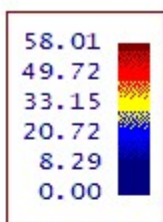

3d

3d(Deformed)

2) $Q_b < 3(Smh)$ (SUS Bending) Case 1

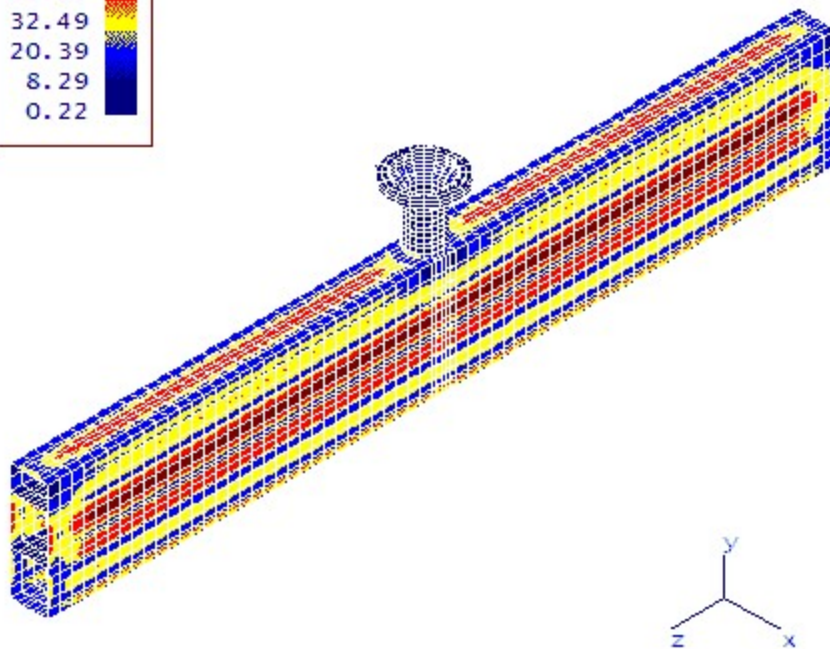
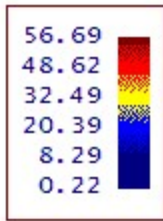

3d 3d(Deformed)

3) $S1+S2+S3 < 4S$ (SUS $S1+S2+S3$) Case 1

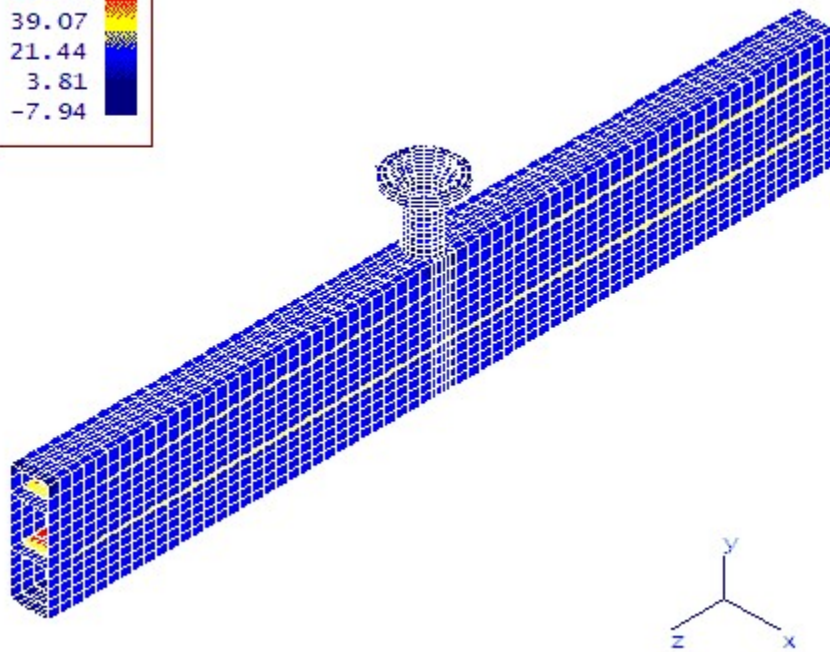
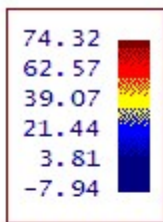

3d 3d(Deformed)

4) $P1+Pb+Q < 3(Smavg)$ (OPE Inside) Case 2

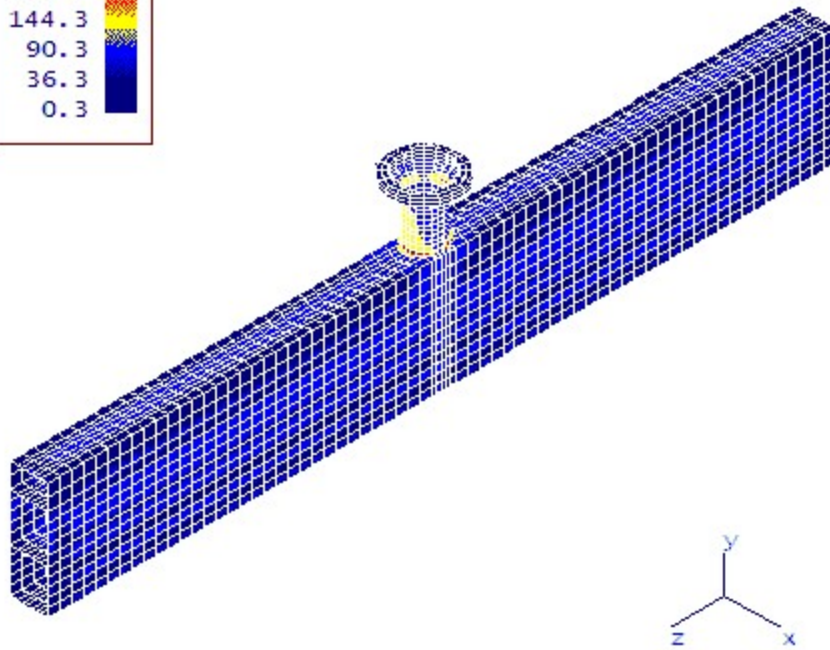
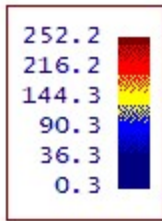

3d

3d(Deformed)

5) $P1+Pb+Q < 3(Smavg)$ (OPE Outside) Case 2

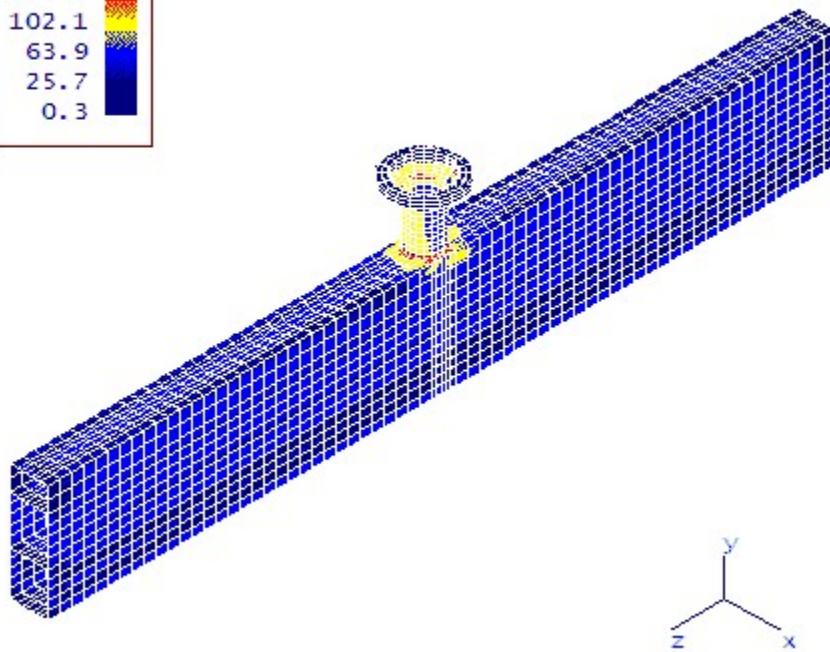
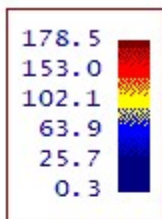

3d

3d(Deformed)

6) $P1+Pb+Q+F < Sa$ (EXP Inside) Case 2

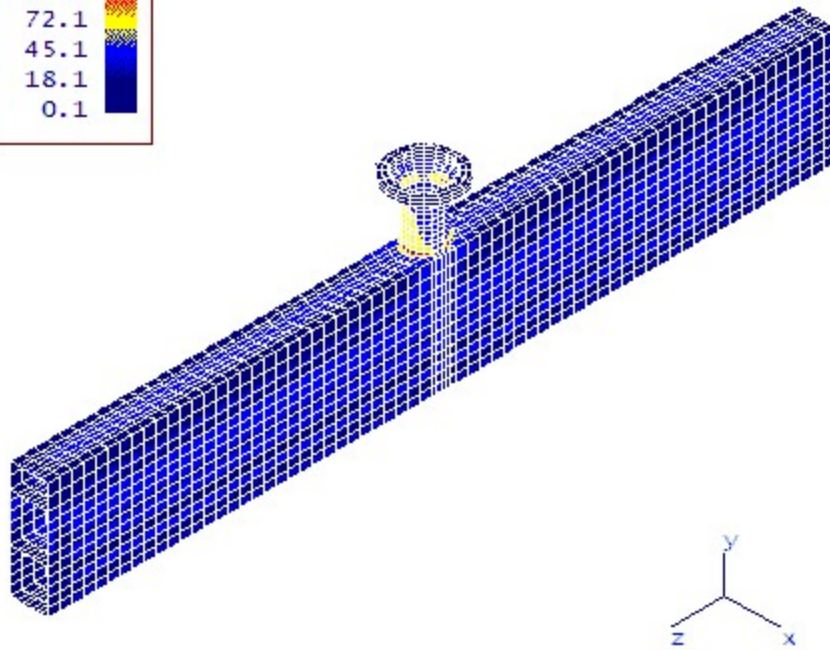
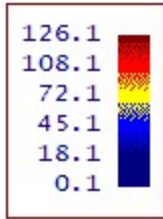

3d 3d(Deformed)

7) $P1+Pb+Q+F < Sa$ (EXP Outside) Case 2

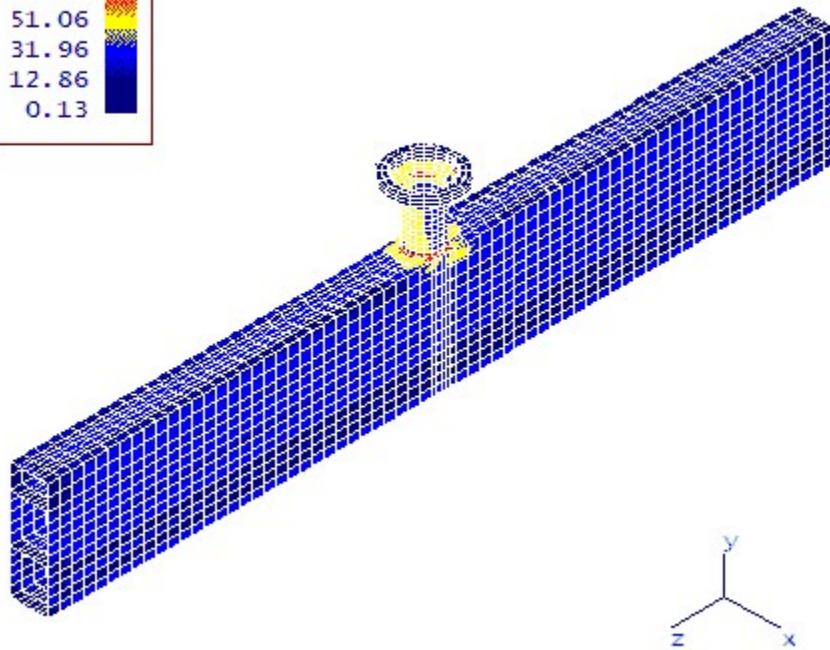
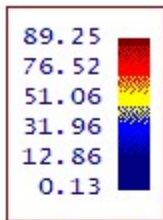

3d 3d(Deformed)

8) Membrane < User (OPE Membrane) Case 2

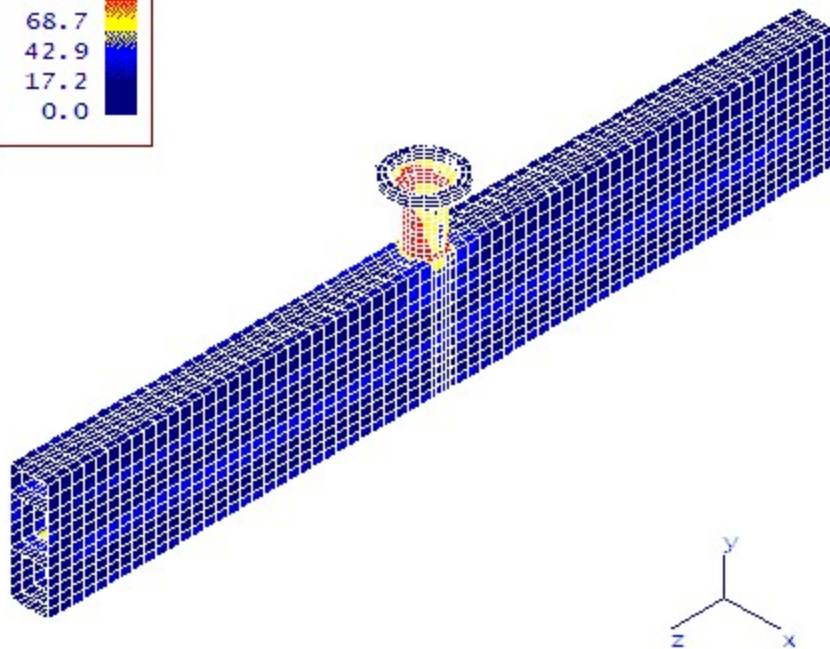
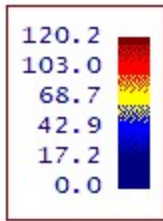

3d 3d(Deformed)

9) Bending < User (OPE Bending) Case 2

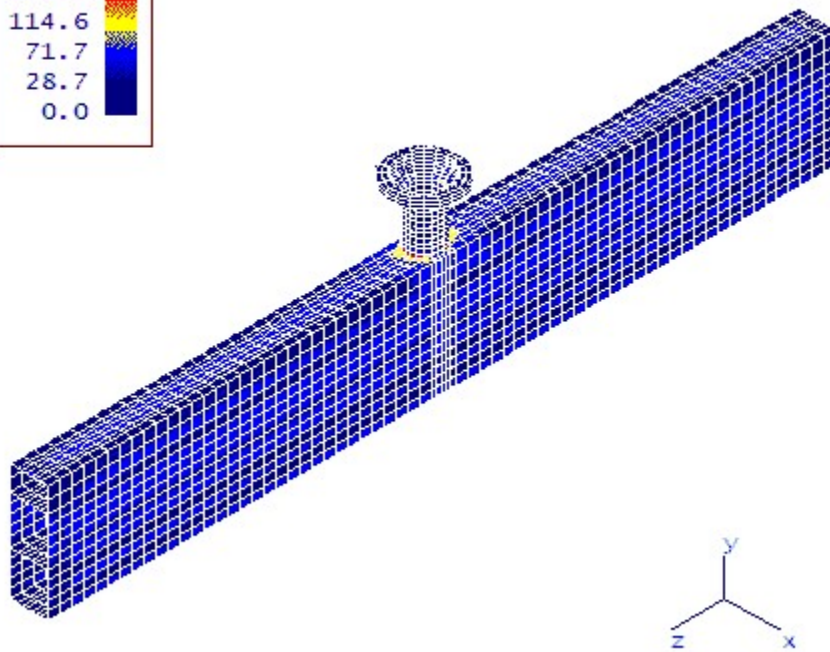
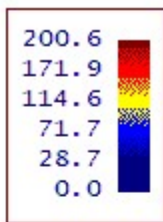

3d 3d(Deformed)

Tabular Results

Results were generated with the finite element program FE/Pipe®. Stress results are post-processed in accordance with the rules specified in ASME Section III and ASME Section VIII, Division 2.

Analysis Time Stamp: Sat Jun 01 10:40:50 2024.

- [Model Notes, Tube Results and API Check](#)
- [Load Case Report](#)
- [Solution Data](#)
- [ASME Code Stress Output Plots](#)
- [Stress Results - Notes](#)
- [ASME Overstressed Areas](#)
- [Highest Primary Stress Ratios](#)
- [Highest Secondary Stress Ratios](#)
- [Highest Fatigue Stress Ratios](#)
- [Graphical Results](#)

Model Notes, Tube Results and API Check
Model Notes, Tube Results and API Check

661PRO 2.0 - API 661 - Air-Cooled Heat Exchanger Nozzle Model

Input Echo:

Notes:

- The centerline of the header box is along the -Z axis.
- Only 1 Nozzle will be modeled at a time. The Nozzle Number Modeled can be seen below.
- User Defined Loads API 661 Check is shown below.
- Sum of ALL Nozzle Loads must not exceed 3*API Allowable Loads shown in Table 4 according to API 661 2002 paragraph 7.1.10.3.
- Results are given as: Actual Load, Allowable Load, percentage of allowable for API Check in lbs. and ft-lbs. for English Units and N. and N-m for SI Units.

```

Nozzle Number Modeled      : 1
Top or Bottom Nozzle      : Bottom

Analysis Type              : User Defined Loads

Nozzle Type                : Straight
Flange Type                : Weldneck
  
```

```

Header Box Dimensions:
Centerline on              :Centerline on LEFT Side
Height                     :      389.000 mm.
Width                      :      140.000 mm.
Length                     :      2510.000 mm.
  
```

```

Outboard Thickness        :      17.000 mm.
Tubesheet Side Thickness :      17.000 mm.
Top Plate Thickness       :      17.000 mm.
Free End Plate Thickness  :      17.000 mm.
  
```

```

Header Box Pressure       :      2.200 MPa
  
```

Header Box Fixed at Centerline

```

Partition Plates:
Number of Partition Plates :      2
  
```

```

Partition Plate #1
Plate Elevation from Bottom :      88.000 mm.
Plate Thickness             :      6.000 mm.
  
```

```

Partition Plate #2
Plate Elevation from Bottom :      240.000 mm.
  
```

Plate Thickness : 6.000 mm.

Nozzle Dimensions:

Distance to CenterLine : 1255.000 mm.
 Nozzle Outside Diameter : 82.500 mm.
 Nozzle Thickness : 12.850 mm.
 Projection to Face of Flange : 200.000 mm.
 Flange Thickness Used : 17.960 mm.
 Flange ID : 100.950 mm.
 Flange Hub Length Used : 26.939 mm.

Weld Size and SCF : 0.000, 1.350

Engineering Details:

Operating Cycles : 7000
 Occasional Cycles : 0
 Ambient Temperature : 21.100 deg.
 Computation Type : Gauss Average

Material Properties

Nozzle:

Cold Allowable Stress : 137.900 MPa
 Hot Allowable Stress : 137.900 MPa
 Elastic Modulus : 0.203E+06 MPa
 Poissons Ratio : 0.300
 Material ID : 2-Low Alloy Steels
 Density : 0.768E-04 N /cu. mm.

Header Box:

Cold Allowable Stress : 137.900 MPa
 Hot Allowable Stress : 137.900 MPa
 Elastic Modulus : 0.203E+06 MPa
 Poissons Ratio : 0.300
 Material ID : 2-Low Alloy Steels
 Density : 0.768E-04 N /cu. mm.

Tubesheet was not modeled

User Defined Loads:

	Forces [N]			Moments [mm.- N]		
	FX	FY	FZ	MX	MY	MZ
Weight	3060	3990	3060	450000	720000	450000
Operating	3060	3990	3060	450000	720000	450000
Occasional	0	0	0	0	0	0

No Tube Results

API Check for User Defined Loads

See Notes Above.

Total Nozzle Loads per DOF in [N]

FX	:	3060,	6000,	51 %
FY	:	3990,	5070,	79 %
FZ	:	3060,	6000,	51 %
MX	:	450,	1230,	37 %
MY	:	720,	1830,	39 %
MZ	:	450,	1230,	37 %

[Table of Contents](#)

Load Case Report
 FE/Pipe Version 7.0
 Released Jul 2014

Jobname: setup2
 10:37am JUN 1,2024

\$P

Load Case Report

\$X

Inner and outer element temperatures are the same throughout the model. No thermal ratcheting

calculations will be performed.

THE 4 LOAD CASES ANALYZED ARE:

1 WEIGHT ONLY (Wgt Only)

Weight ONLY case run to get the stress range between the installed and the operating states.

/----- Loads in Case 1
Loads due to Weight

2 SUSTAINED (Wgt+Pr)

Sustained case run to satisfy local primary membrane and bending stress limits.

/----- Loads in Case 2
Loads due to Weight
Pressure Case 1

3 OPERATING

Case run to compute the operating stresses used in secondary, peak and range calculations as needed.

/----- Loads in Case 3
Pressure Case 1
Loads from (Operating)

4 RANGE (Fatigue Calc Performed)

Case run to get the RANGE of stresses.

/----- Combinations in Range Case 4
Plus Stress Results from CASE 3
Minus Stress Results from CASE 1

[Table of Contents](#)

Solution Data

FE/Pipe Version 7.0 Jobname: setup2 \$P
Released Jul 2014 10:38am JUN 1,2024

Solution Data

Maximum Solution Row Size = 1740
Number of Nodes = 12063
Number of Elements = 4107
Number of Solution Cases = 3

Summation of Loads per Case

Case #	FX	FY	FZ
1	3060.	5575.	3060.
2	3060.	32418.	-97603.
3	3060.	32418.	-97603.

[Table of Contents](#)

ASME Code Stress Output Plots

FE/Pipe Version 7.0 Jobname: setup2 \$P
Released Jul 2014 10:40am JUN 1,2024

ASME Code Stress Output Plots \$X

1) P1 < 1.5(k)Smh (SUS,Membrane) Case 2

2) Qb < 3(Smh) (SUS,Bending) Case 2

- 3) $S1+S2+S3 < 4S$ (SUS,S1+S2+S3) Case 2
- 4) $Pl+Pb+Q < 3(Smavg)$ (OPE,Inside) Case 3
- 5) $Pl+Pb+Q < 3(Smavg)$ (OPE,Outside) Case 3
- 6) Membrane $< User$ (OPE,Membrane) Case 3
- 7) Bending $< User$ (OPE,Bending) Case 3
- 8) $Pl+Pb+Q < 3(Smavg)$ (EXP,Inside) Case 4
- 9) $Pl+Pb+Q < 3(Smavg)$ (EXP,Outside) Case 4
- 10) $Pl+Pb+Q+F < Sa$ (EXP,Inside) Case 4
- 11) $Pl+Pb+Q+F < Sa$ (EXP,Outside) Case 4

[Table of Contents](#)

Stress Results - Notes

FE/Pipe Version 7.0 Jobname: setup2 \$P
Released Jul 2014 10:40am JUN 1,2024

Stress Results - Notes

- Results in this analysis were generated using the finite element solution method.
- Using pre 07 ASME Section VIII Division 2
- Assume free end displacements of attached pipe are secondary loads within limits of nozzle reinforcement.
- Use Stress Intensity (TRESCA).
- $S1+S2+S3$ evaluation omitted from operating stress. Include $S1+S2+S3$ evaluation in primary case evaluation. Assume bending stress not local primary for $S1+S2+S3$.
- Use local tensor values for averaged and not averaged stresses.
 - PRIMARY STRESSES are similar to the B31 code "sustained" stresses. Primary stresses contain the effects due to weight, pressure and other sustained loads. The primary limit for this stress is based on collapse of the local cross section or excessive local strain.
 - SECONDARY (PL+PB+Q) STRESS has no direct equal in a B31 code. This stress requirement is intended to insure that significant inelastic behavior only occurs for the first few loading cycles, and only over a fairly small region of the model. "Small" is on the order of the square root of Rt , where (R) is the radius of the header and (t) is the thickness of the header. Secondary stresses do not include the effect of peak stress concentration factors such as occur at fillets, welds or notches.
 - PEAK STRESSES are equivalent to the B31 code "expansion" stresses. In the peak stress report, the user will find the equivalent B31 allowable computed from: $f[1.25(Sc+Sh)]$.
 - The LOCAL STRESS calculations performed herein are in accordance with ASME VIII Div 2, Part 5, elastic calculations, and ASME Section III Subsection NB. These methods have been used extensively in the nuclear piping industry, and have been shown to be in consistent agreement with the B31 piping codes when the simplifying assumptions made in the B31 codes are employed.
 - The B31 Code Stress Calculations performed herein are in accordance with the method outlined in NUREG/CR-3243 and (ORNL/Sub/82-22252/1). This paper shows the relationship between the fatigue evaluation methods used in the B31 codes and the class 1,2 and 3 nuclear piping codes.

Circ Plate for Plate # 4

Pl	1.5(k)Smh	Primary Membrane Load Case 2
26	207	Sect VIII Ref: AD-140, 4-112(i), 4-133,
MPa	MPa	Fig. 4-130.1, Table 4-120.1
		Plot Reference:
12%		1) Pl < 1.5(k)Smh (SUS,Membrane) Case 2

Long Plate for Plate # 4

Pl	1.5(k)Smh	Primary Membrane Load Case 2
6	207	Sect VIII Ref: AD-140, 4-112(i), 4-133,
MPa	MPa	Fig. 4-130.1, Table 4-120.1
		Plot Reference:
2%		1) Pl < 1.5(k)Smh (SUS,Membrane) Case 2

[Table of Contents](#)

Highest Secondary Stress Ratios

FE/Pipe Version 7.0 Jobname: setup2 \$P
Released Jul 2014 10:40am JUN 1,2024

Highest Secondary Stress Ratios

\$X

Circ Plate for Plate # 1

Pl+Pb+Q	3(Smavg)	Primary+Secondary (Inner) Load Case 3
67	414	Sect VIII Ref: 4-120(b)(4), 4-134, 4-136.6,
MPa	MPa	Fig. 4-130.1(Note 1)
		Plot Reference:
16%		4) Pl+Pb+Q < 3(Smavg) (OPE,Inside) Case 3

Long Plate for Plate # 1

Pl+Pb+Q	3(Smavg)	Primary+Secondary (Outer) Load Case 3
82	414	Sect VIII Ref: 4-120(b)(4), 4-134, 4-136.6,
MPa	MPa	Fig. 4-130.1(Note 1)
		Plot Reference:
19%		5) Pl+Pb+Q < 3(Smavg) (OPE,Outside) Case 3

Circ Plate for Plate # 2

Pl+Pb+Q	3(Smavg)	Primary+Secondary (Inner) Load Case 3
65	414	Sect VIII Ref: 4-120(b)(4), 4-134, 4-136.6,
MPa	MPa	Fig. 4-130.1(Note 1)
		Plot Reference:
15%		4) Pl+Pb+Q < 3(Smavg) (OPE,Inside) Case 3

Circ Plate for Plate # 3

Pl+Pb+Q	3(Smavg)	Primary+Secondary (Inner) Load Case 3
159	414	Sect VIII Ref: 4-120(b)(4), 4-134, 4-136.6,
MPa	MPa	Fig. 4-130.1(Note 1)
		Plot Reference:
38%		4) Pl+Pb+Q < 3(Smavg) (OPE,Inside) Case 3

Circ Plate for Plate # 4

Pl+Pb+Q	3(Smavg)	Primary+Secondary (Inner) Load Case 3
56	414	Sect VIII Ref: 4-120(b)(4), 4-134, 4-136.6,
MPa	MPa	Fig. 4-130.1(Note 1)
		Plot Reference:
13%		4) Pl+Pb+Q < 3(Smavg) (OPE,Inside) Case 3

Long Plate for Plate # 4

Pl+Pb+Q	3(Smavg)	Primary+Secondary (Outer) Load Case 3
10	414	Sect VIII Ref: 4-120(b)(4), 4-134, 4-136.6,
MPa	MPa	Fig. 4-130.1(Note 1)
		Plot Reference:

2%

5) Pl+Pb+Q < 3(Smavg) (OPE,Outside) Case 3

[Table of Contents](#)

Highest Fatigue Stress Ratios

FE/Pipe Version 7.0

Jobname: setup2

\$P

Released Jul 2014

10:40am JUN 1,2024

Highest Fatigue Stress Ratios

\$X

Circ Plate for Plate # 1

Pl+Pb+Q+F	Sa	Primary+Secondary+Peak (Inner) Load Case 4
32	290	Stress Concentration Factor = 1.000
MPa	MPa	Strain Concentration Factor = 1.000
		Cycles Allowed for this Stress = 1.0000E11
11%		"B31" Fatigue Stress Allowable = 344.8
		Mark1 Fatigue Stress Allowable = 287.5
		WRC 474 Mean Cycles to Failure = 17,652,156.
		WRC 474 99% Probability Cycles = 4,100,752.
		WRC 474 95% Probability Cycles = 5,693,378.
		BS5500 Allowed Cycles(Curve F) = 2,541,689.
		Membrane-to-Bending Ratio = 0.330
		Bending-to-PL+PB+Q Ratio = 0.752
		Sect VIII Ref: 4-112(1)(2),Fig.4-130.1,4-135
		Plot Reference:
		10) Pl+Pb+Q+F < Sa (EXP,Inside) Case 4

Long Plate for Plate # 1

Pl+Pb+Q+F	Sa	Primary+Secondary+Peak (Outer) Load Case 4
20	290	Stress Concentration Factor = 1.000
MPa	MPa	Strain Concentration Factor = 1.000
		Cycles Allowed for this Stress = 1.0000E11
6%		"B31" Fatigue Stress Allowable = 344.8
		Mark1 Fatigue Stress Allowable = 287.5
		WRC 474 Mean Cycles to Failure = 76,564,944.
		WRC 474 99% Probability Cycles = 17,786,732.
		WRC 474 95% Probability Cycles = 24,694,636.
		BS5500 Allowed Cycles(Curve F) = 11,041,011.
		Membrane-to-Bending Ratio = 0.423
		Bending-to-PL+PB+Q Ratio = 0.703
		Sect VIII Ref: 4-112(1)(2),Fig.4-130.1,4-135
		Plot Reference:
		11) Pl+Pb+Q+F < Sa (EXP,Outside) Case 4

Circ Plate for Plate # 2

Pl+Pb+Q+F	Sa	Primary+Secondary+Peak (Inner) Load Case 4
32	290	Stress Concentration Factor = 1.000
MPa	MPa	Strain Concentration Factor = 1.000
		Cycles Allowed for this Stress = 1.0000E11
11%		"B31" Fatigue Stress Allowable = 344.8
		Mark1 Fatigue Stress Allowable = 287.5
		WRC 474 Mean Cycles to Failure = 17,649,554.
		WRC 474 99% Probability Cycles = 4,100,147.
		WRC 474 95% Probability Cycles = 5,692,538.
		BS5500 Allowed Cycles(Curve F) = 2,542,080.
		Membrane-to-Bending Ratio = 0.330
		Bending-to-PL+PB+Q Ratio = 0.752
		Sect VIII Ref: 4-112(1)(2),Fig.4-130.1,4-135
		Plot Reference:
		10) Pl+Pb+Q+F < Sa (EXP,Inside) Case 4

Circ Plate for Plate # 3

Pl+Pb+Q+F	Sa	Primary+Secondary+Peak (Inner) Load Case 4
21	290	Stress Concentration Factor = 1.000
MPa	MPa	Strain Concentration Factor = 1.000
		Cycles Allowed for this Stress = 1.0000E11
7%		"B31" Fatigue Stress Allowable = 344.8
		Mark1 Fatigue Stress Allowable = 287.5
		WRC 474 Mean Cycles to Failure = 83,741,728.
		WRC 474 99% Probability Cycles = 19,453,966.
		WRC 474 95% Probability Cycles = 27,009,382.

BS5500 Allowed Cycles(Curve F) = 9,217,872.
 Membrane-to-Bending Ratio = 0.316
 Bending-to-PL+PB+Q Ratio = 0.760
 Sect VIII Ref: 4-112(1) (2), Fig.4-130.1,4-135
 Plot Reference:
 10) Pl+Pb+Q+F < Sa (EXP,Inside) Case 4

Circ Plate for Plate # 4

Pl+Pb+Q+F	Sa	Primary+Secondary+Peak (Inner) Load Case 4
7	290	Stress Concentration Factor = 1.000
MPa	MPa	Strain Concentration Factor = 1.000
		Cycles Allowed for this Stress = 1.0000E11
2%		"B31" Fatigue Stress Allowable = 344.8
		Mark1 Fatigue Stress Allowable = 287.5
		WRC 474 Mean Cycles to Failure = 2.9154E9
		WRC 474 99% Probability Cycles = 6.7728E8
		WRC 474 95% Probability Cycles = 9.4031E8
		BS5500 Allowed Cycles(Curve F) = 3.0971E9
		Membrane-to-Bending Ratio = 1.660
		Bending-to-PL+PB+Q Ratio = 0.376
		Sect VIII Ref: 4-112(1) (2), Fig.4-130.1,4-135
		Plot Reference:
		10) Pl+Pb+Q+F < Sa (EXP,Inside) Case 4

Long Plate for Plate # 4

Pl+Pb+Q+F	Sa	Primary+Secondary+Peak (Inner) Load Case 4
2	290	Stress Concentration Factor = 1.000
MPa	MPa	Strain Concentration Factor = 1.000
		Cycles Allowed for this Stress = 1.0000E11
0%		"B31" Fatigue Stress Allowable = 344.8
		Mark1 Fatigue Stress Allowable = 287.5
		WRC 474 Mean Cycles to Failure = 7.6867E10
		WRC 474 99% Probability Cycles = 1.7857E10
		WRC 474 95% Probability Cycles = 2.4792E10
		BS5500 Allowed Cycles(Curve F) = 9.3069E11
		Membrane-to-Bending Ratio = 2.391
		Bending-to-PL+PB+Q Ratio = 0.295
		Sect VIII Ref: 4-112(1) (2), Fig.4-130.1,4-135
		Plot Reference:
		10) Pl+Pb+Q+F < Sa (EXP,Inside) Case 4

Circ Plate for Plate # 5

Pl+Pb+Q+F	Sa	Primary+Secondary+Peak (Inner) Load Case 4
32	290	Stress Concentration Factor = 1.000
MPa	MPa	Strain Concentration Factor = 1.000
		Cycles Allowed for this Stress = 1.0000E11
11%		"B31" Fatigue Stress Allowable = 0.0
		Mark1 Fatigue Stress Allowable = 287.5
		WRC 474 Mean Cycles to Failure = 36,376,952.
		WRC 474 99% Probability Cycles = 8,450,688.
		WRC 474 95% Probability Cycles = 11,732,729.
		BS5500 Allowed Cycles(Curve F) = 2,542,065.
		Membrane-to-Bending Ratio = 0.330
		Bending-to-PL+PB+Q Ratio = 0.752
		Sect VIII Ref: 4-112(1) (2), Fig.4-130.1,4-135
		Plot Reference:
		10) Pl+Pb+Q+F < Sa (EXP,Inside) Case 4

[Table of Contents](#)

Finite Element Model

- [Finite Element Model](#)
- [1\) \$PI < 1.5\(k\)Smh\$ \(SUS Membrane\) Case 2](#)
- [2\) \$Qb < 3\(Smh\)\$ \(SUS Bending\) Case 2](#)
- [3\) \$S1+S2+S3 < 4S\$ \(SUS \$S1+S2+S3\$ \) Case 2](#)
- [4\) \$PI+Pb+Q < 3\(Smavg\)\$ \(OPE Inside\) Case 3](#)
- [5\) \$PI+Pb+Q < 3\(Smavg\)\$ \(OPE Outside\) Case 3](#)
- [6\) Membrane < User \(OPE Membrane\) Case 3](#)
- [7\) Bending < User \(OPE Bending\) Case 3](#)
- [8\) \$PI+Pb+Q < 3\(Smavg\)\$ \(EXP Inside\) Case 4](#)
- [9\) \$PI+Pb+Q < 3\(Smavg\)\$ \(EXP Outside\) Case 4](#)
- [10\) \$PI+Pb+Q+F < Sa\$ \(EXP Inside\) Case 4](#)
- [11\) \$PI+Pb+Q+F < Sa\$ \(EXP Outside\) Case 4](#)

Finite Element Model

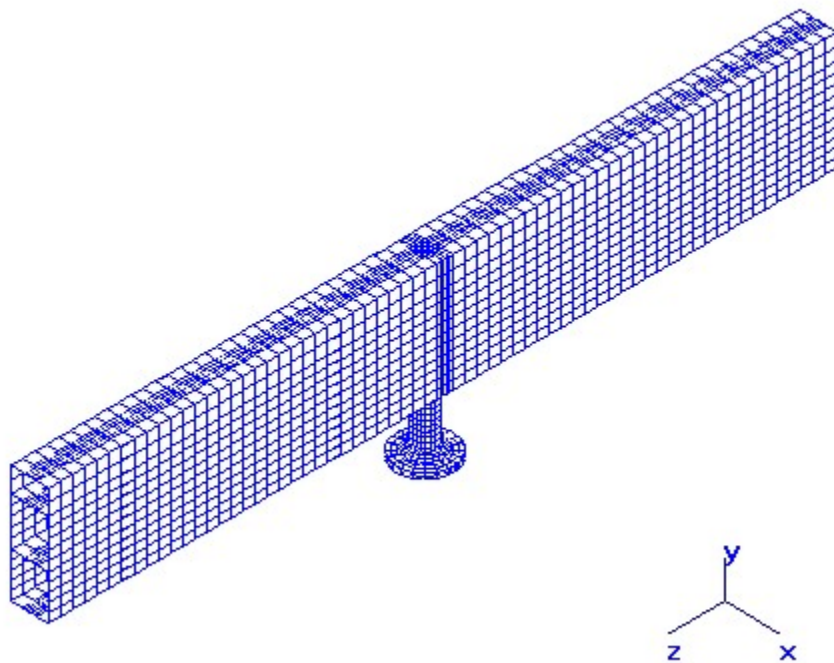

3d

1) P1 < 1.5(k)Smh (SUS Membrane)_Case 2

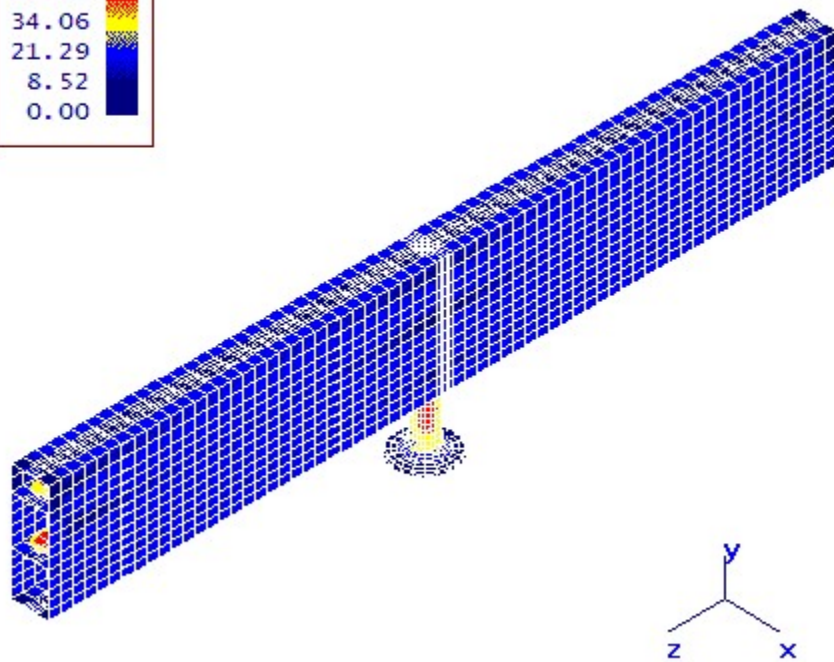
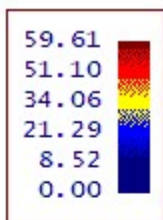

3d

3d(Deformed)

2) $Q_b < 3(Smh)$ (SUS Bending) Case 2

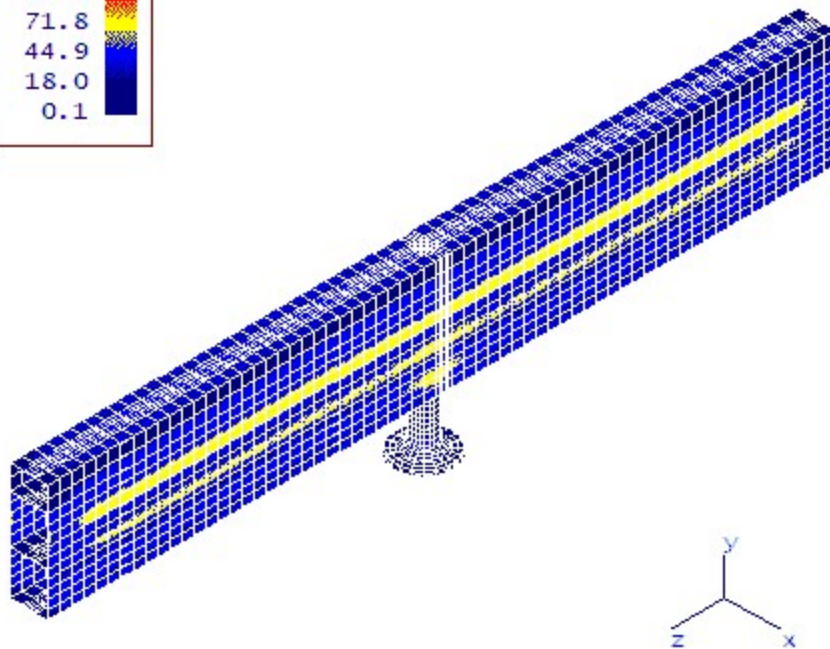
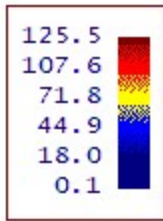

3d 3d(Deformed)

3) $S1+S2+S3 < 4S$ (SUS $S1+S2+S3$) Case 2

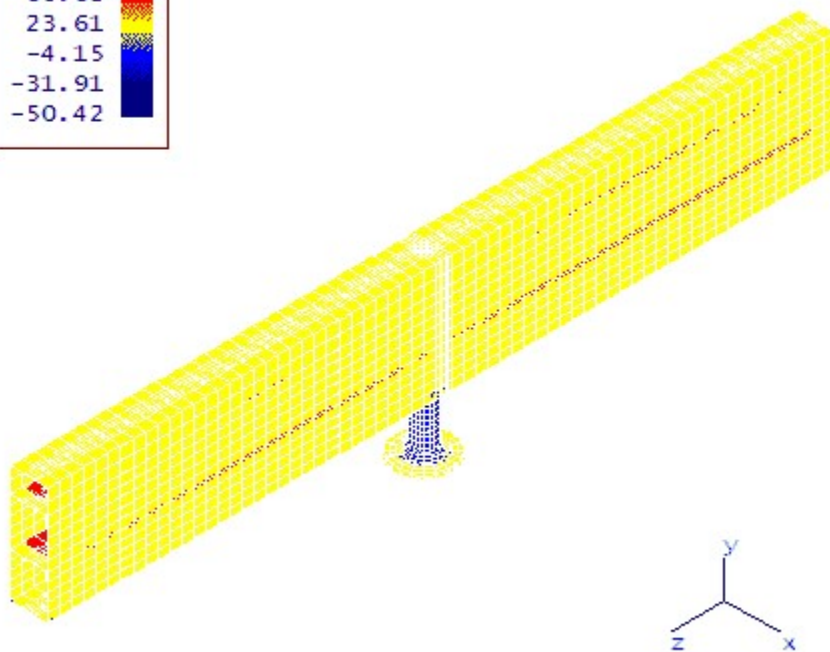
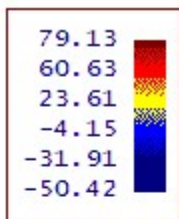

3d 3d(Deformed)

4) $P1+Pb+Q < 3(Smavg)$ (OPE Inside) Case 3

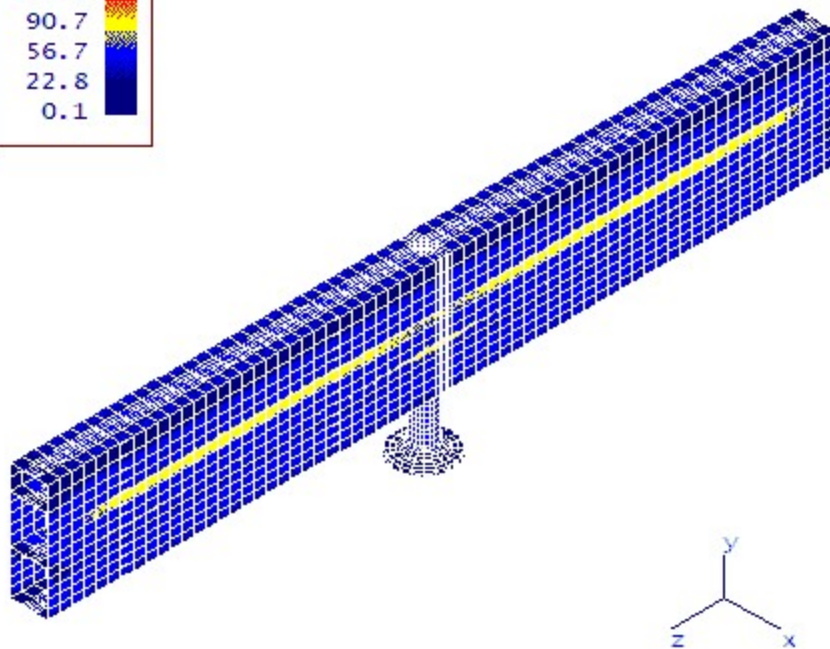
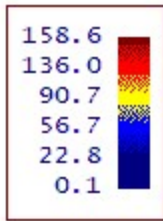

3d 3d(Deformed)

5) $P1+Pb+Q < 3(Smavg)$ (OPE Outside) Case 3

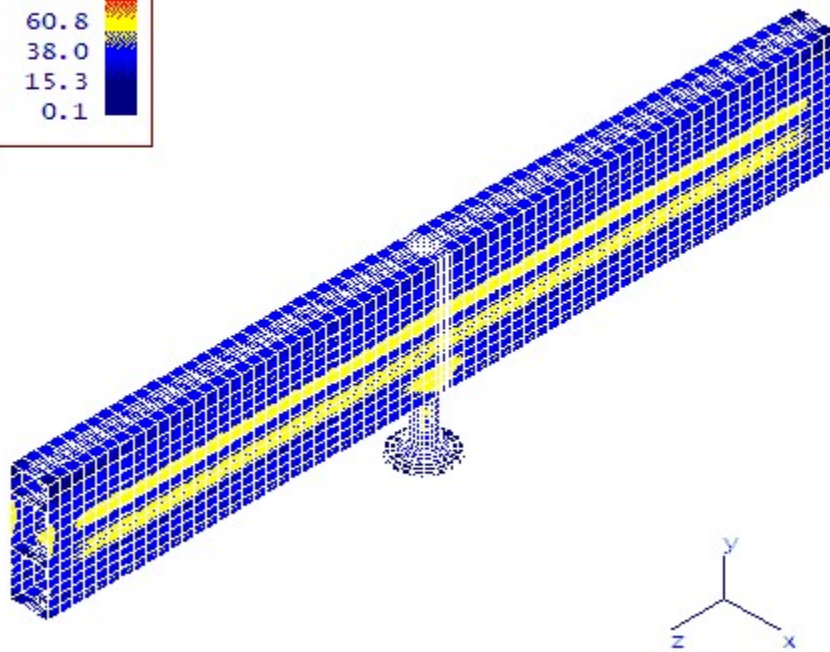
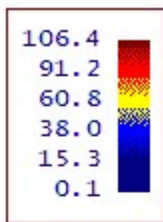

3d 3d(Deformed)

6) Membrane < User (OPE Membrane) Case 3

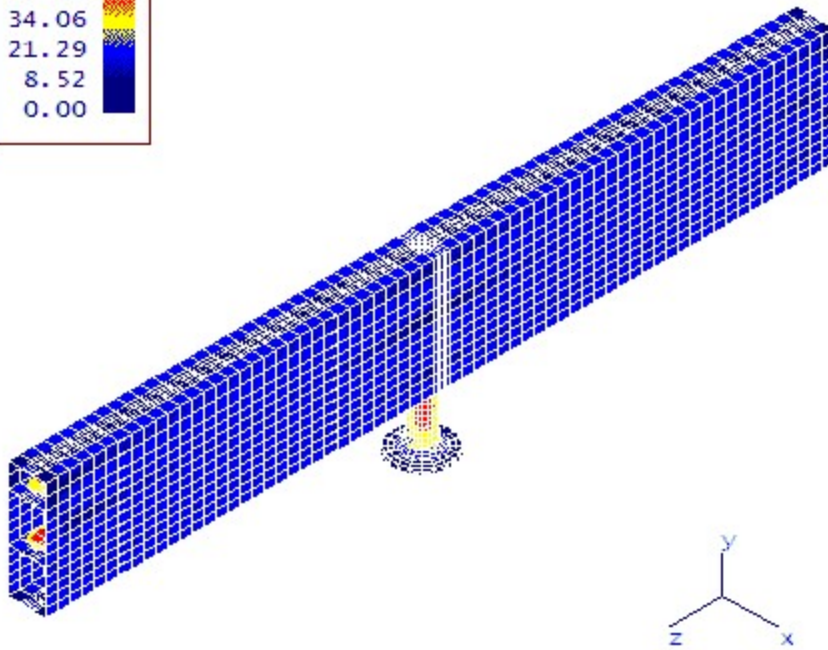
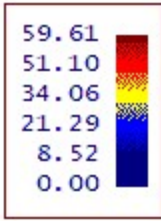

3d 3d(Deformed)

7) Bending < User (OPE Bending) Case 3

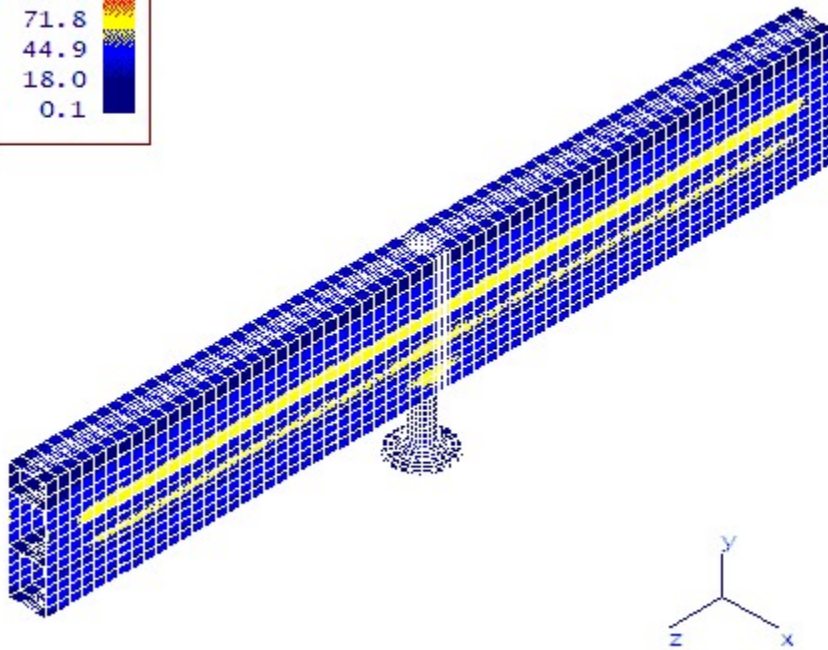
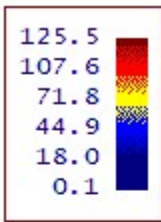

3d 3d(Deformed)

8) $P1+Pb+Q < 3(Smavg)$ (EXP Inside) Case 4

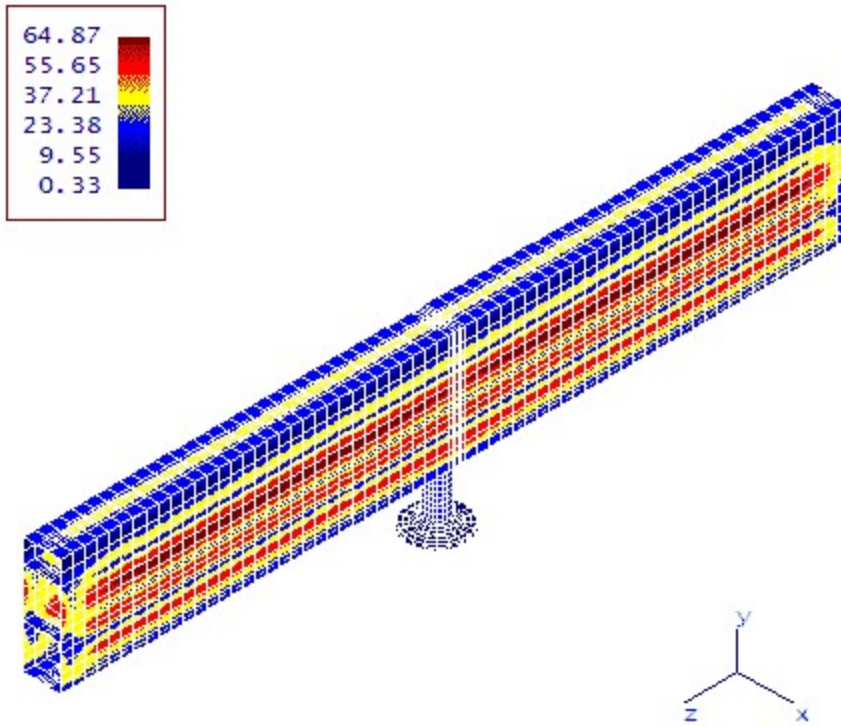

3d

9) $P1+Pb+Q < 3(Smavg)$ (EXP Outside) Case 4

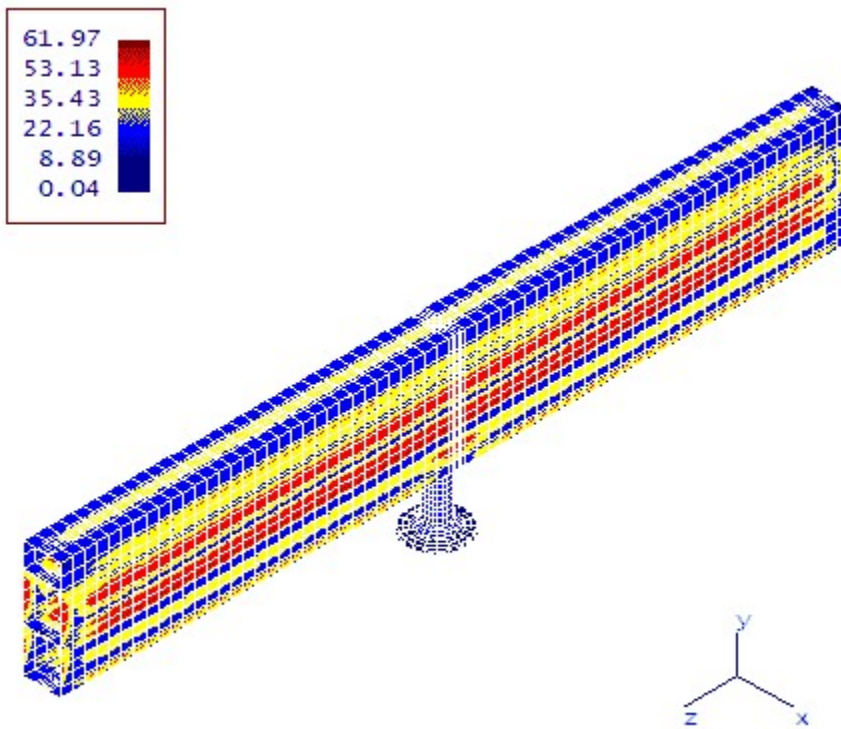

3d

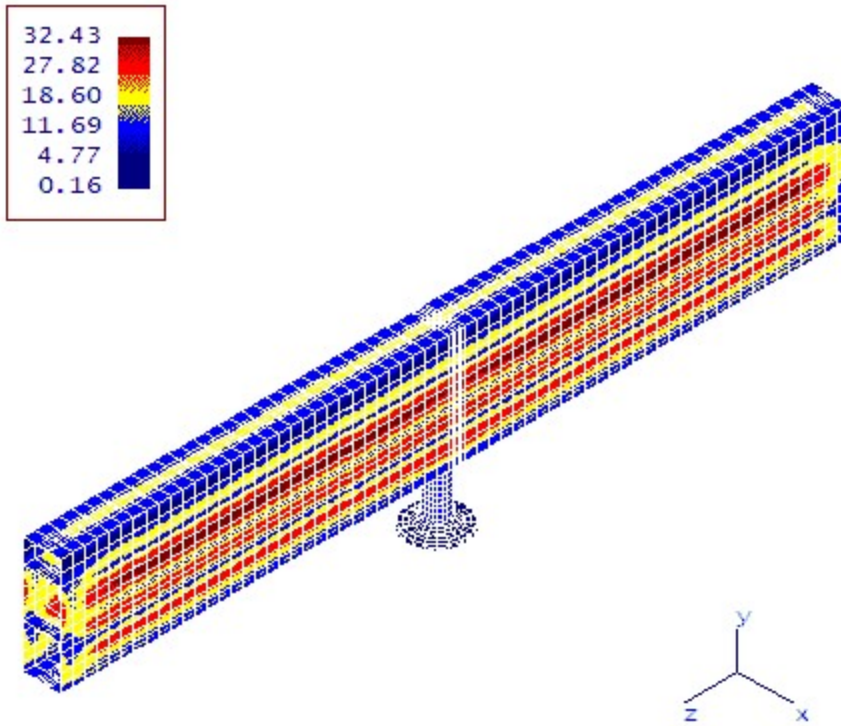
10) $P1+Pb+Q+F < Sa$ (EXP Inside) Case 4

3d

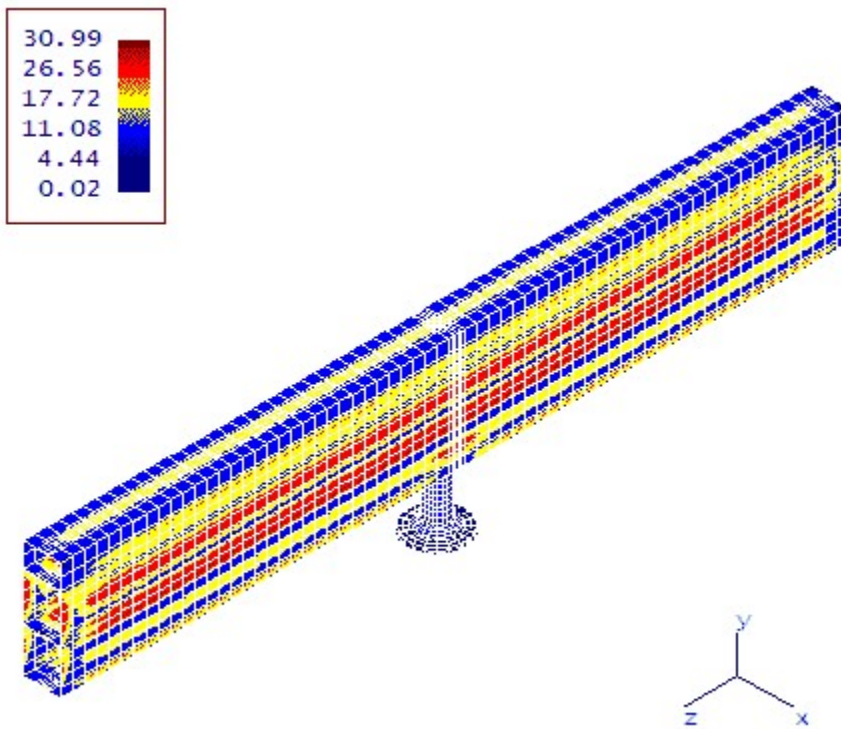
11) $P1+Pb+Q+F < Sa$ (EXP Outside) Case 4

3d