

REAR HEADER (SLIDING HEADER)

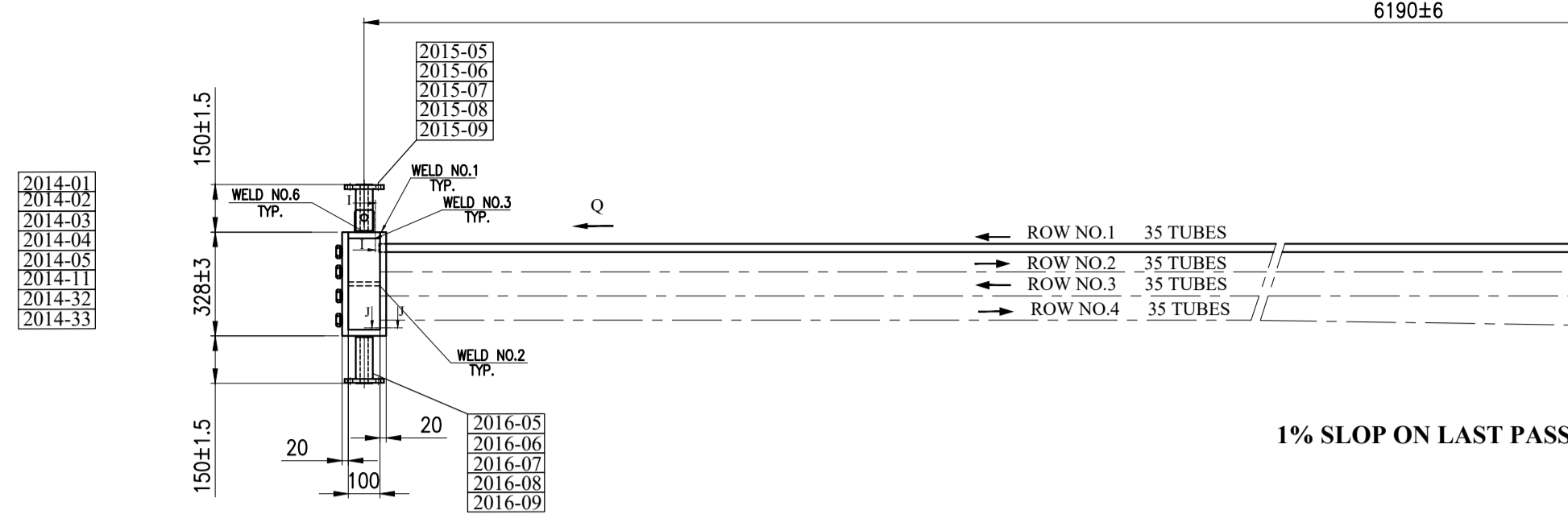

FRONT HEADER (FIXED HEADER)

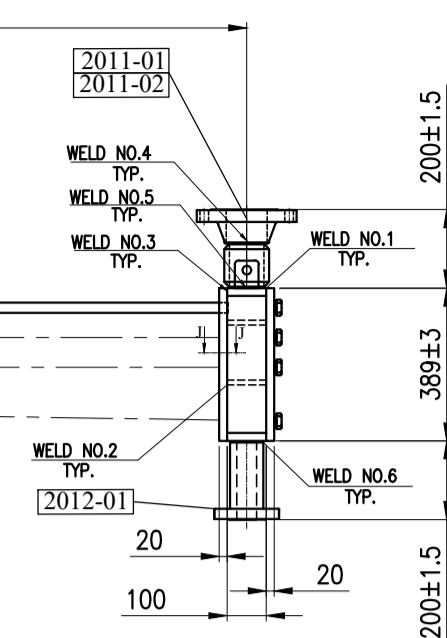

- NOTES :
- 1- ALL DIMENSIONS ARE IN MILLIMETERS.
 - 2- ALL NOZZLE FACINGS SHALL BE PROTECTED BY COVER AND 4 BOLTS.
 - 3- FLANGE CONTACT FACES SHALL BE COATED WITH GREASE.
 - 4- ALL FLANGE BOLTS SHALL STRADDLE MAIN AXES.
 - 5- ALL ENGINEERING AND MANUFACTURING CHARACTERISTICS NOT MENTIONED ON THIS DRAWING ARE INDICATED ON THE FOLLOWING APPLICABLE DOCUMENTS :
 - A- CALCULATION BOOK
 - B- WELDING PROCEDURE SPECIFICATION (W.P.S.)
 - C- NON DESTRUCTIVE TEST CHECK LIST (N.D.T.)
 - D- PAINTING & GALVANIZING SPECIFICATION SHEETS
 - 6- HEADER PLUG THREADS SHALL BE COVERED BY ANTI SEIZE GREASE PROPER FOR 200°C TEMPERATURE.
 - 7- THE MATERIAL OF THE SLIDING PAD BETWEEN THE BUNDLE FRAME AND THE HEADER IS TEFLON(PTFE), FOR MORE INFORMATION, REFER TO DWG. NO. EI027-DMF-VD-ME-DWG-007

THE MAXIMUM ALLOWABLE MOMENTS AND FORCES PER EACH NOZZLE (IF LOADS ARE DIVIDED EQUALLY FOR NOZZLES ACCORDING TO 3rd API 681(7.1.10.1))

SIZE	Fx(N)	Fy(N)	Fz(N)	Mx(N.m)	My(N.m)	Mz(N.m)
4"	10020	8010	10020	2430	3660	2430
2"	3060	3990	3060	450	720	450

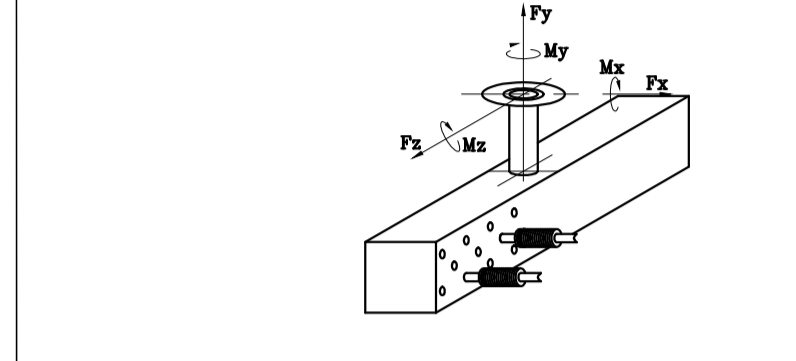

LATERAL DISPLACEMENT OF HEADERS (DIRECTION Z) INSIDE BUNDLE FRAME IN RELATION WITH EXPANSION FORCES ON NOZZLES (mm) (ACCORDING TO API681 7-1-1-2)

MAXIMUM DISPLACEMENT OF FRONT AND REAR HEADER(Z DIRECTION) INLET/OUTLET : ±9

NOZZLE ALIGNMENT TOLERANCES

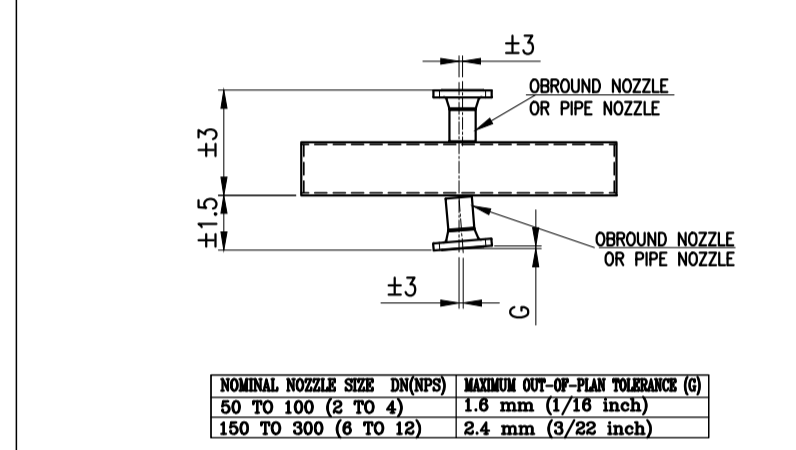

FIN TUBE DETAIL

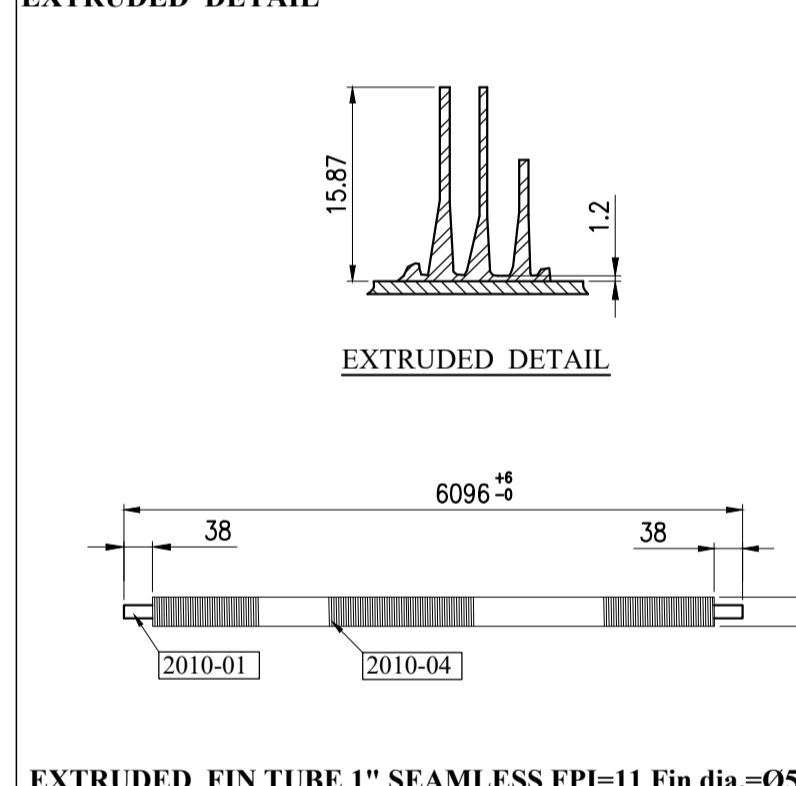

EXTRUDED FIN TUBE 1" SEAMLESS FPI=11 Fin dia.=Ø57.15

PART NO.	DESCRIPTION	DIMENSIONS			MATERIAL	QTY	UNIT WEIGHT (Kg)	TOTAL WEIGHT (Kg)	STD DWG	REV.
		DIA (mm)	LENGTH (mm)	THK (mm)						
2000-00	A TUBE BUNDLE INCLUDING :	-	-	-	-	2	2221.9	5444	-	-
2010-00	EXTRUDED FINNED TUBE INCLUDING :	-	-	-	-	-	-	2010.7	-	-
2010-01	BASE TUBE 1" (SEAMLESS-MIN WALL-BWG16)	25.4	6096	1.65	SA-334 Gr.6	140	6.0	913.2	-	-
2010-04	ALUMINUM TUBE	35.75	5212.08	4.9	AL-1000	140	7.8	1097.5	-	-
2011-00	INLET NOZZLE INCLUDING :	-	-	-	-	-	-	11.0	-	-
2011-01	PIPE NOZZLE 4" , SCH 160 (SEAMLESS)	107	-	13.49	SA-333 Gr.6	1	3.9	3.9	-	-
2011-02	FLANGE 4" (ANSI B16.5.300#WNRF)	254	88	-	SA-350 LF2 CL.1N	1	7.1	7.1	-	-
2012-00	OUTLET NOZZLE INCLUDING :	-	-	-	-	-	-	3.5	-	-
2012-01	NOZZLE 2" (ANSI B16.5.300#LWNRF)	165	198	16.6	SA-350 LF2 CL.1N	1	3.5	3.5	-	-
2013-00	FRONT HEADER INCLUDING :	-	-	-	-	-	-	448.8	-	-
2013-01	TUBE SHEET	-	2510	389	20	-	-	1	153.3	153.3
2013-02	PLUG SHEET	-	2510	389	20	-	-	1	153.3	153.3
2013-03	TOP PLATE	-	2510	100	20	-	-	1	39.4	39.4
2013-04	BOTTOM PLATE	-	2510	100	20	-	-	1	39.4	39.4
2013-05	END PLATE	-	349	100	20	-	-	2	6.5	11.0
2013-11	PARTITION	-	2470	100	12	-	-	2	23.3	46.6
2013-32	SLIDING PAD	-	10690	80	12	-	-	2	1.6	3.1
2013-33	FIXING	-	70	60	12	-	-	2	0.4	0.8
2014-00	REAR HEADER INCLUDING :	-	-	-	-	-	-	-	-	-
2014-01	TUBE SHEET	-	2510	328	20	-	-	1	139.3	139.3
2014-02	PLUG SHEET	-	2510	328	20	-	-	1	139.3	139.3
2014-03	TOP PLATE	-	2510	100	20	-	-	1	39.4	39.4
2014-04	BOTTOM PLATE	-	2510	100	20	-	-	1	39.4	39.4
2014-05	END PLATE	-	238	100	20	-	-	2	4.5	9.0
2014-11	PARTITION	-	2470	100	12	-	-	1	23.3	23.3
2014-32	SLIDING PAD	-	10690	80	12	-	-	2	1.6	3.1
2014-33	FIXING	-	70	60	12	-	-	2	0.4	0.8
2015-00	VENT INCLUDING :	-	-	-	-	-	-	-	-	-
2015-01	FLANGE LWN 1" 300# RF	124	146	-	14.3	-	-	2	2.0	4.0
2015-02	BLIND FOR FLANGE LWN 1" 300# RF	-	-	-	-	-	-	2	1.5	3.0
2015-03	GASKET FOR FLANGE LWN 1" 300# RF	-	-	-	-	-	-	-	-	-
2015-04	STUD BOLT FOR FLANGE LWN 1" 300# RF	M16	80	-	-	-	-	8	-	-
2015-05	NUT	M16	-	-	-	-	-	16	-	-
2016-00	DRAIN INCLUDING :	-	-	-	-	-	-	-	-	-
2016-01	FLANGE LWN 1" 300# RF	124	146	-	14.3	-	-	2	2.0	4.0
2016-02	BLIND FOR FLANGE LWN 1" 300# RF	-	-	-	-	-	-	2	1.5	3.0
2016-03	GASKET FOR FLANGE LWN 1" 300# RF	-	-	-	-	-	-	-	-	-
2016-04	STUD BOLT FOR FLANGE LWN 1" 300# RF	M16	80	-	-	-	-	8	-	-
2016-05	NUT	M16	-	-	-	-	-	16	-	-
2020-00	MISCELLANEOUS PARTS INCLUDING :	-	-	-	-	-	-	-	-	-
2020-01	PLUG (1 1/8" 12 UNF CL.2A)	-	-	-	-	-	-	62.3	-	-
2020-02	PLUG GASKET	3095.6	-	-	-	-	-	280	-	2296
2020-05	STAND FOR BRACKET	-	150	60	5	-	-	1	0.35	0.7

MARK NO.	SERVICE	SIZE	NOZZLE MATERIAL	FLANGE MATERIAL	RATING	TYPE	FACING	SCH. THK.	FLANGE FACE FINISHING	QTY. PER BUNDLE	ITEM
N1	INLET NOZZLE	4"	SA-333 Gr.6	SA-350 LF2 CL.1N	300W	LWN	RF	16.6	25-250 µm	1	2
N2	OUTLET NOZZLE	2"	SA-350 LF2 CL.1N	-	300W	LWN	RF	16.6	25-250 µm	1	2
V1,V2	VENT WITH BLIND & GASKET	1"	SA-350 LF2 CL.1N	-	300W	LWN	-	-	-	2	4
D1,D2	DRAIN WITH BLIND & GASKET	1"	SA-350 LF2 CL.1N	-	300W	LWN	-	-	-	2	4

APPLICABLE CODES AND STANDARDS	
SERVICE	PROPANE
MAXIMUM DESIGN TEMPERATURE (°C)	120
MINIMUM DESIGN AMBIENT TEMPERATURE (°C)	5
DESIGN PRESSURE (barg)	22+F.V.
TEST PRESSURE (barg)	3
CORROSION ALLOWANCE	0.480
WELD JOINT EFFICIENCY	0.6 FOR PARTITION / 0.85 FOR OTHER PARTS
HYDROTEST	YES
POST WELD HEAT TREATMENT	YES
N.D.T. EXAMINATION OF WELDED JOINTS	SEE NDT CHECK LIST
TUBE TO TUBE SHEET JOINT	STRENGTH WELD = EXPANDED
BUNDLE CAPACITY (m ³)	0.480
BUNDLE WEIGHT WITH FRAME (EMPTY) (Kg)	2920
BUNDLE WEIGHT WITH FRAME (FULL OF WATER) (Kg)	3400
ULTRASONIC TESTING (NOZZLE TO HEADER)	YES

REFERENCE DOCUMENTS		
TITLE	VENDOR DOCUMENT NO.	CLIENT DOCUMENT NO.
GENERAL ARRANGEMENT	1158-A01-1000-00	EI027-DMF-VD-ME-DWG-003
BUNDLE FRAME	1158-A01-2400-00	EI027-DMF-VD-ME-DWG-007
AIR COOLER DATA SHEET	1158-A01-0010-00	EI027-DMF-VD-ME-DSH-002
MECHANICAL CALCULATION	1158-A01-0020-00	EI027-DMF-VD-ME-CAL-006
WELDING PROCEDURE SPECIFICATION (W.P.S.)	1158-A01-0060-00	EI027-DMF-VD-QC-WPS-021
NON DESTRUCTIVE TEST CHECK LIST (N.D.T.)	1158-A01-0070-00	EI027-DMF-VD-QC-PRO-022

REV	DATE	DESCRIPTION	DRAWN BY	CHECKED BY	APPROVED BY	FINAL APPROVED BY
R2	07/22/2024	ISSUED FOR APPROVAL	F.SZ	S.S	J.B.L	A.GHZ
R1	06/26/2024	ISSUED FOR APPROVAL	F.SZ	S.S	J.B.L	A.GHZ
R0	06/02/2024	ISSUED FOR APPROVAL	F.SZ	S.S	J.B.L	A.GHZ

CLIENT: _____ CONTRACTOR: _____

ENBR TEKNOLOJİ

PROJECT : AIR COOLER FOR Toase-che Park Sanati Gohar Ofogh Petrochemical Co.

TUBE BUNDLE DRAWING 1158-A01-2000-00

DWG. NO. EI027-DMF-VD-ME-DWG-005

SCALE : N.T.S. SIZE : A1 REV. : 02

Factory : Km 14 special Karaj road

dt Damafin thermal technology

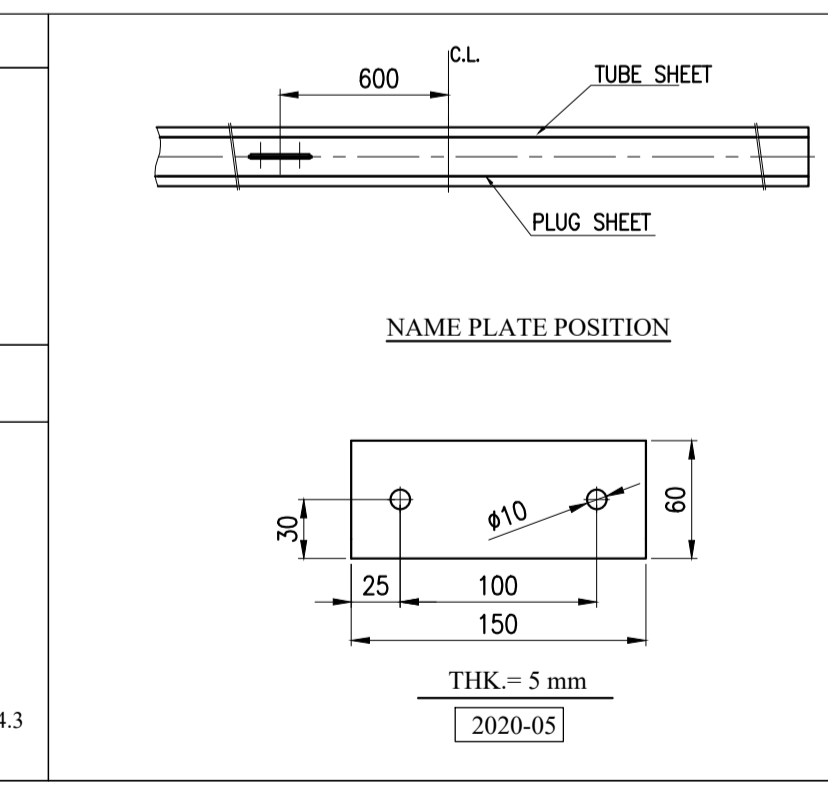
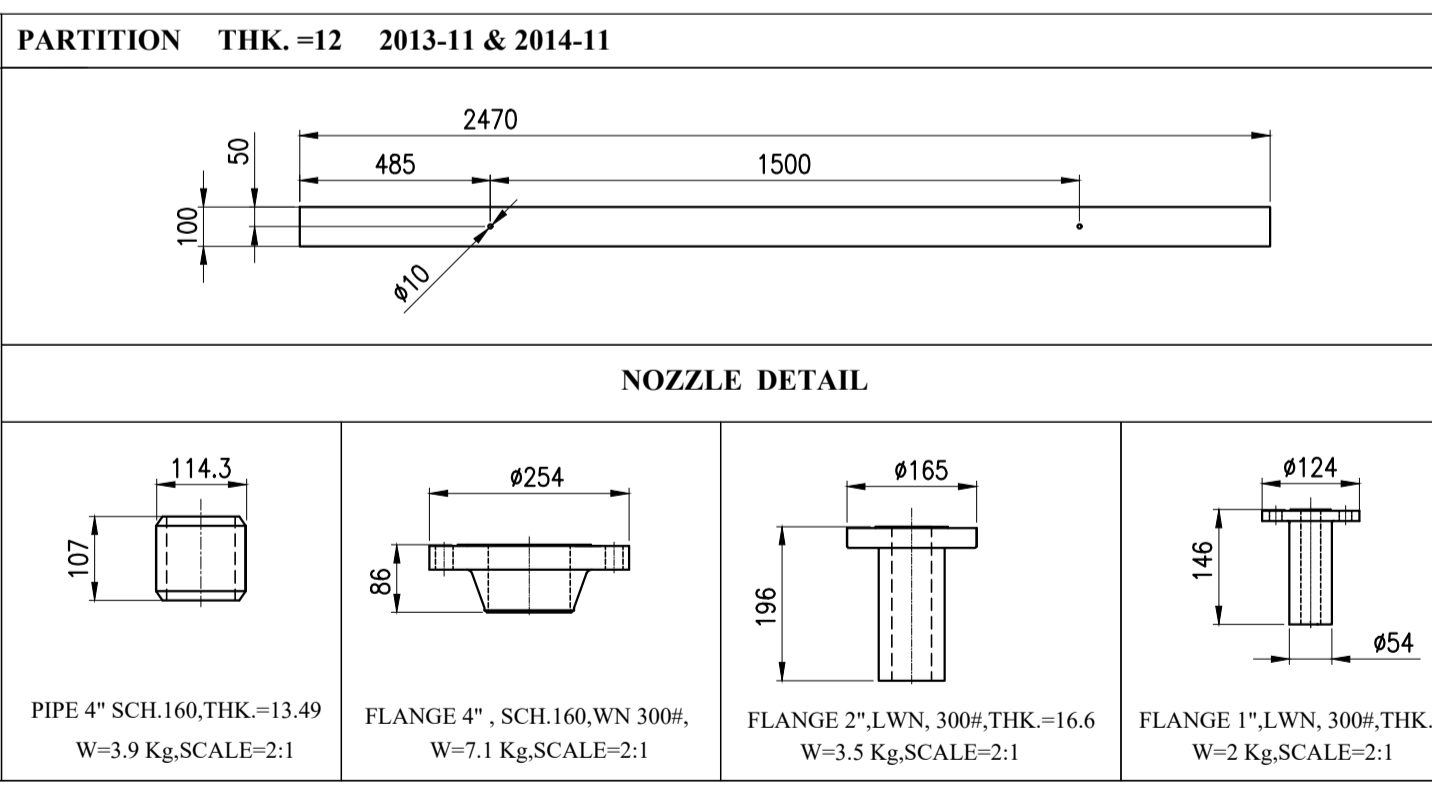
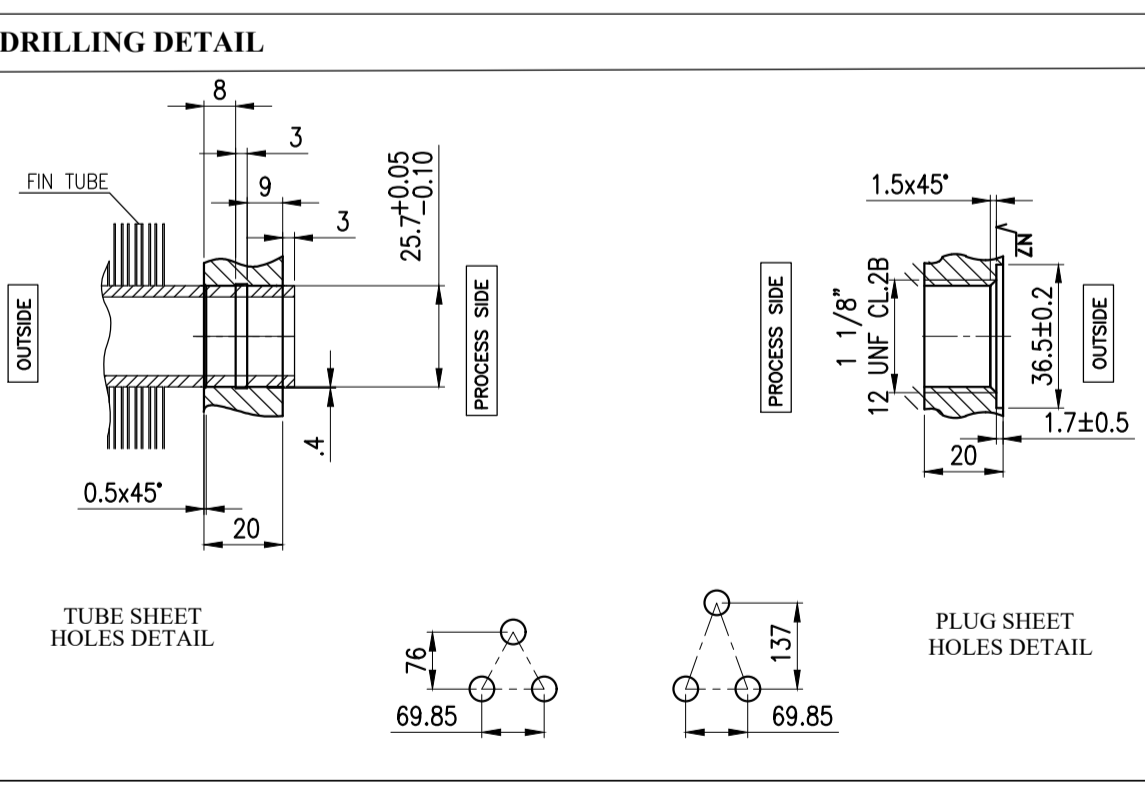
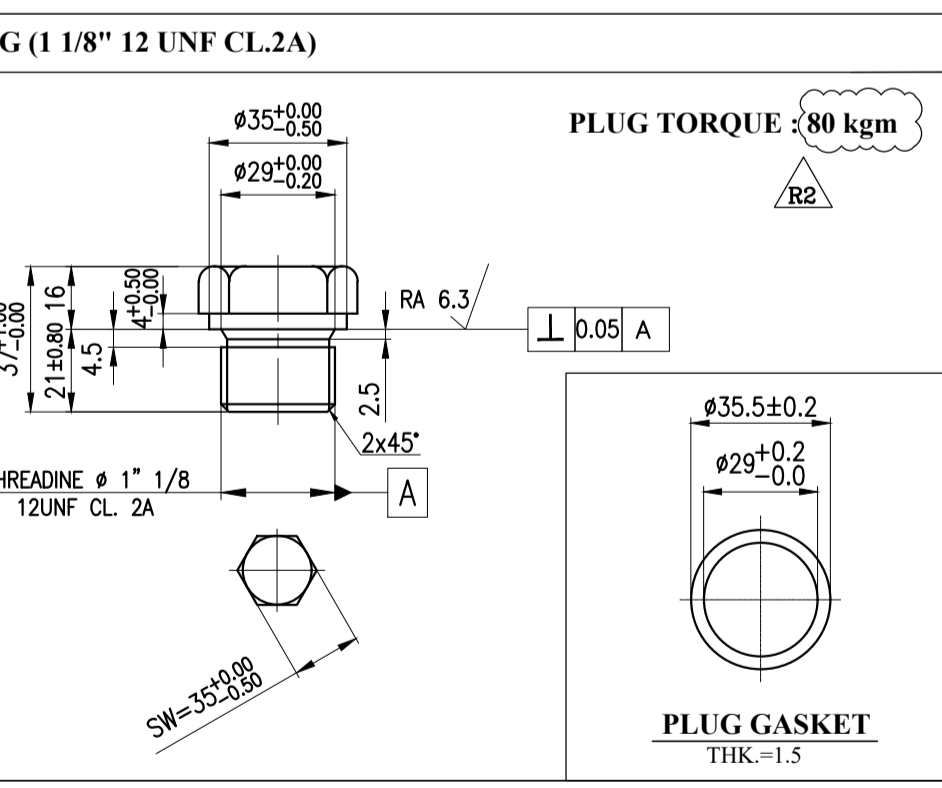
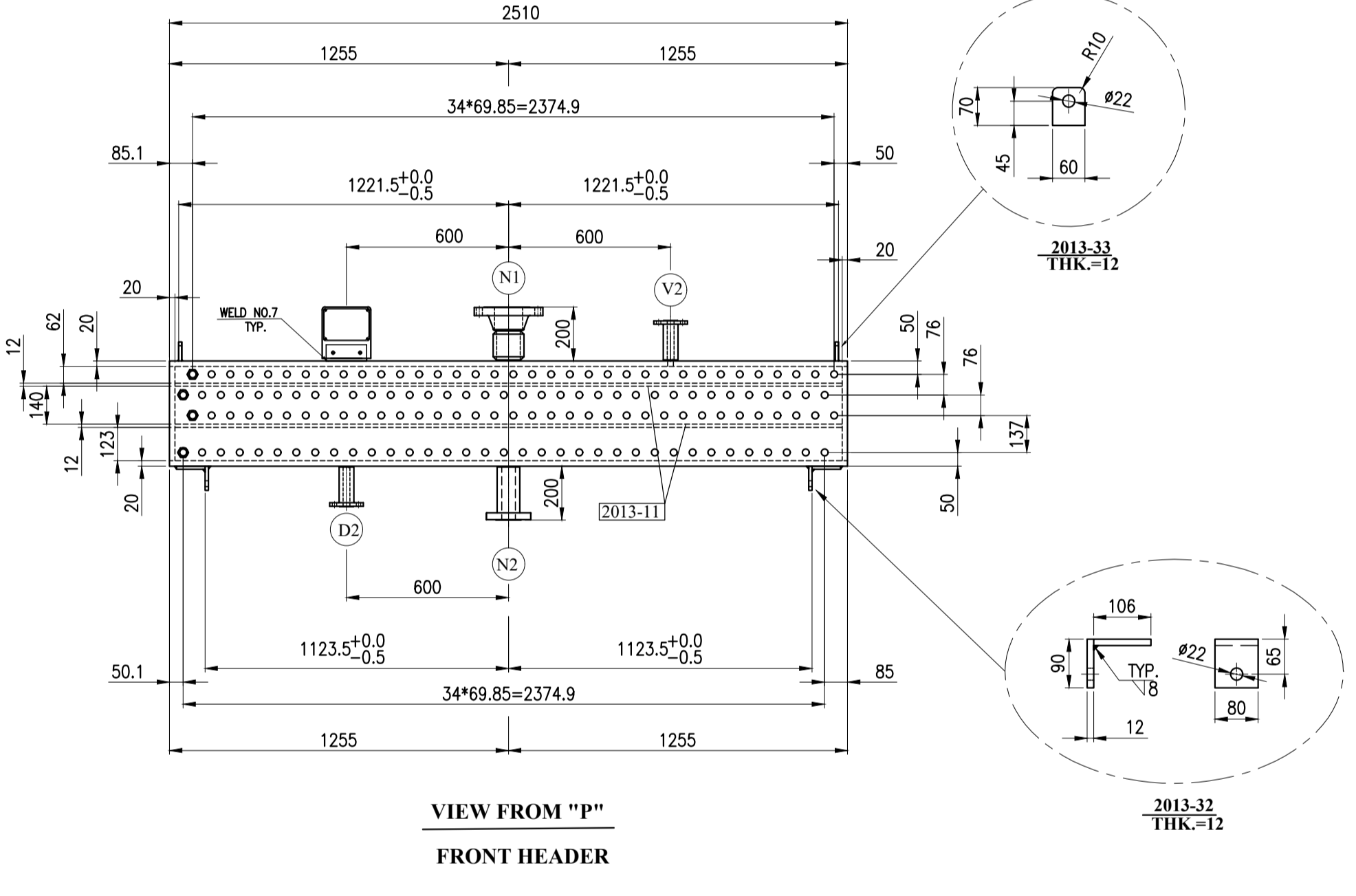
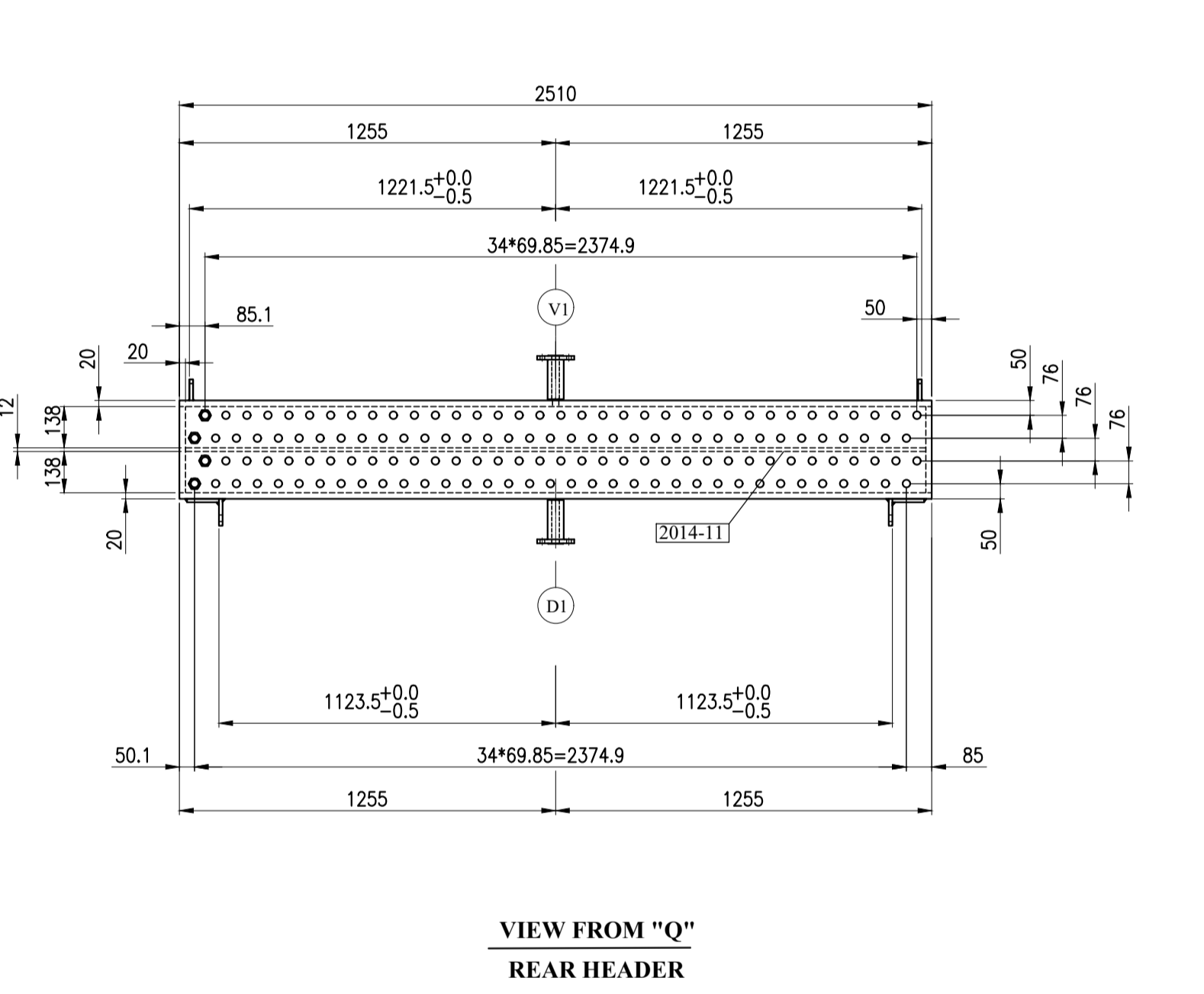
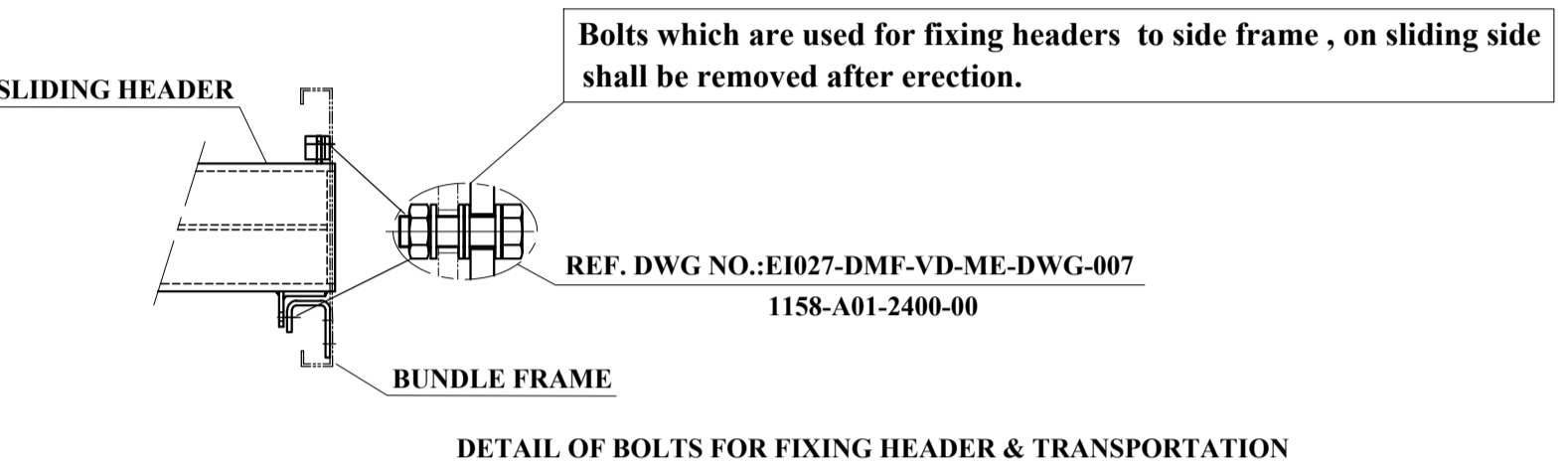

WELD NO.	WELD NO.	WELD NO.	WELD NO.	WELD NO.	WELD NO.	WELD NO.	WELD NO.
DS11-W010/01	DS11-W010/02	DS11-W011/01	DS11-W012/01	DS11-W012/02	DS11-W012/03	DS11-W014/01	DS11-W025/01