

FRONT VIEW CL. A-C
* THIS DIMENSION WILL BE FINALIZED AFTER APPROVED OF MOTOR DATA SHEET

SIDE VIEW

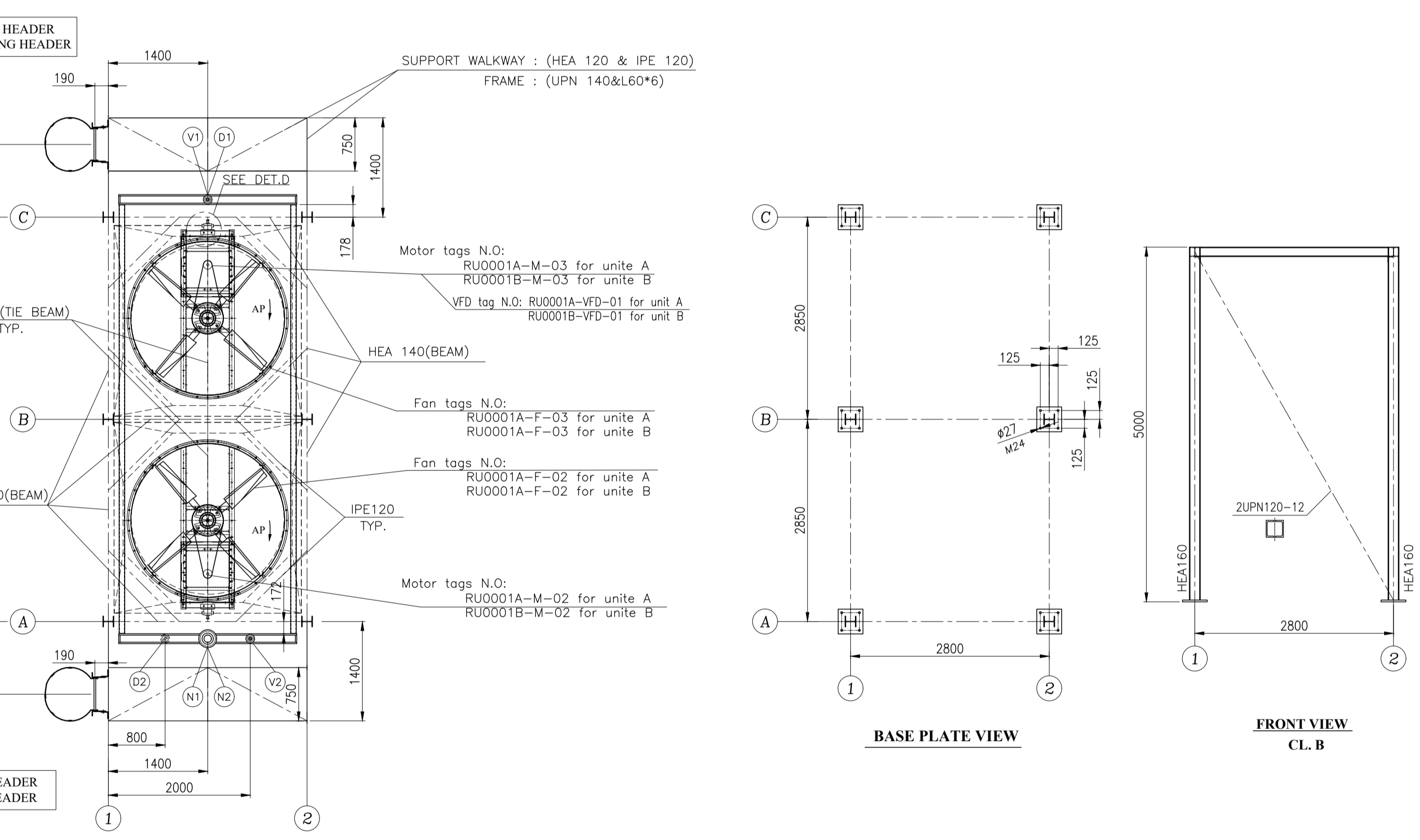

TOP VIEW

BASE PLATE VIEW

FRONT VIEW CL. B

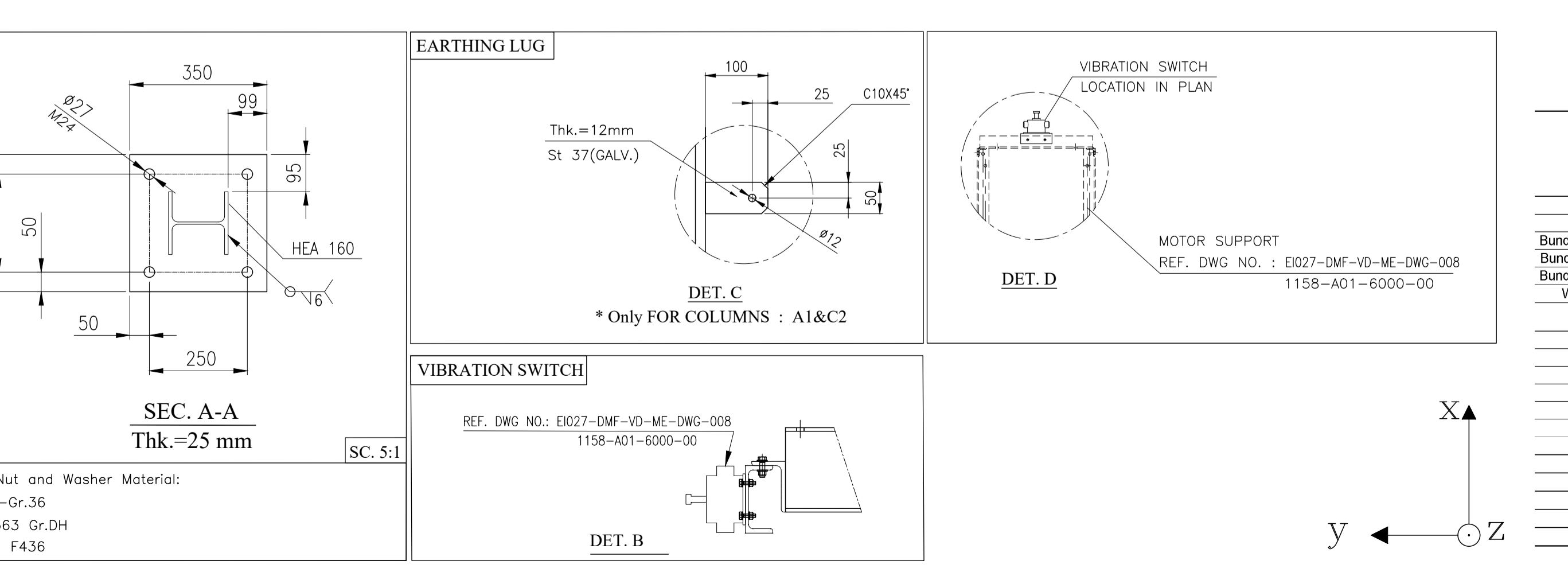

Anchor bolt, Nut and Washer Material:
Bolt: F1554-Gr.36
Nut: ASTM A563 Gr.DH
Washer: ASTM F436

REF. DWG NO.: E1027-DMF-VD-ME-DWG-008
1158-A01-6000-00

REF. DWG NO.: E1027-DMF-VD-ME-DWG-008
1158-A01-6000-00

REF. DWG NO.: E1027-DMF-VD-ME-DWG-008
1158-A01-6000-00

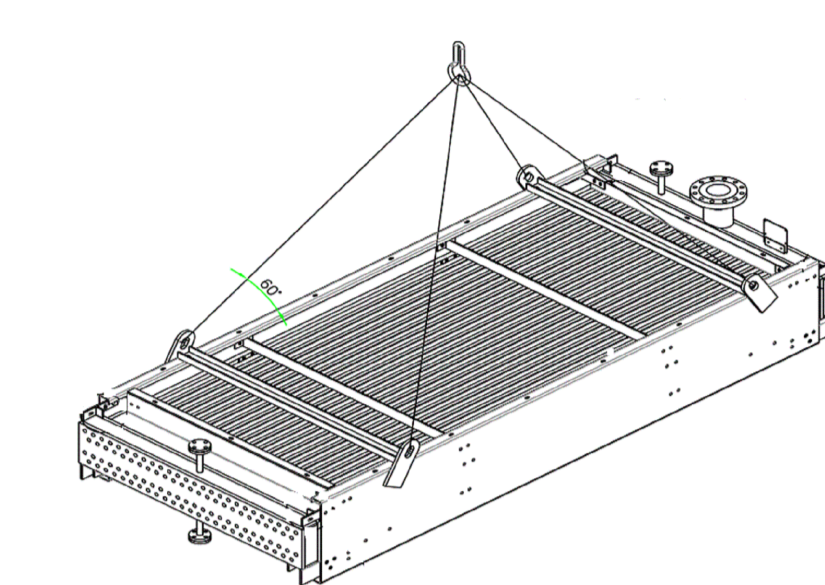

SCHEMATIC OF BUNDLE LIFTING

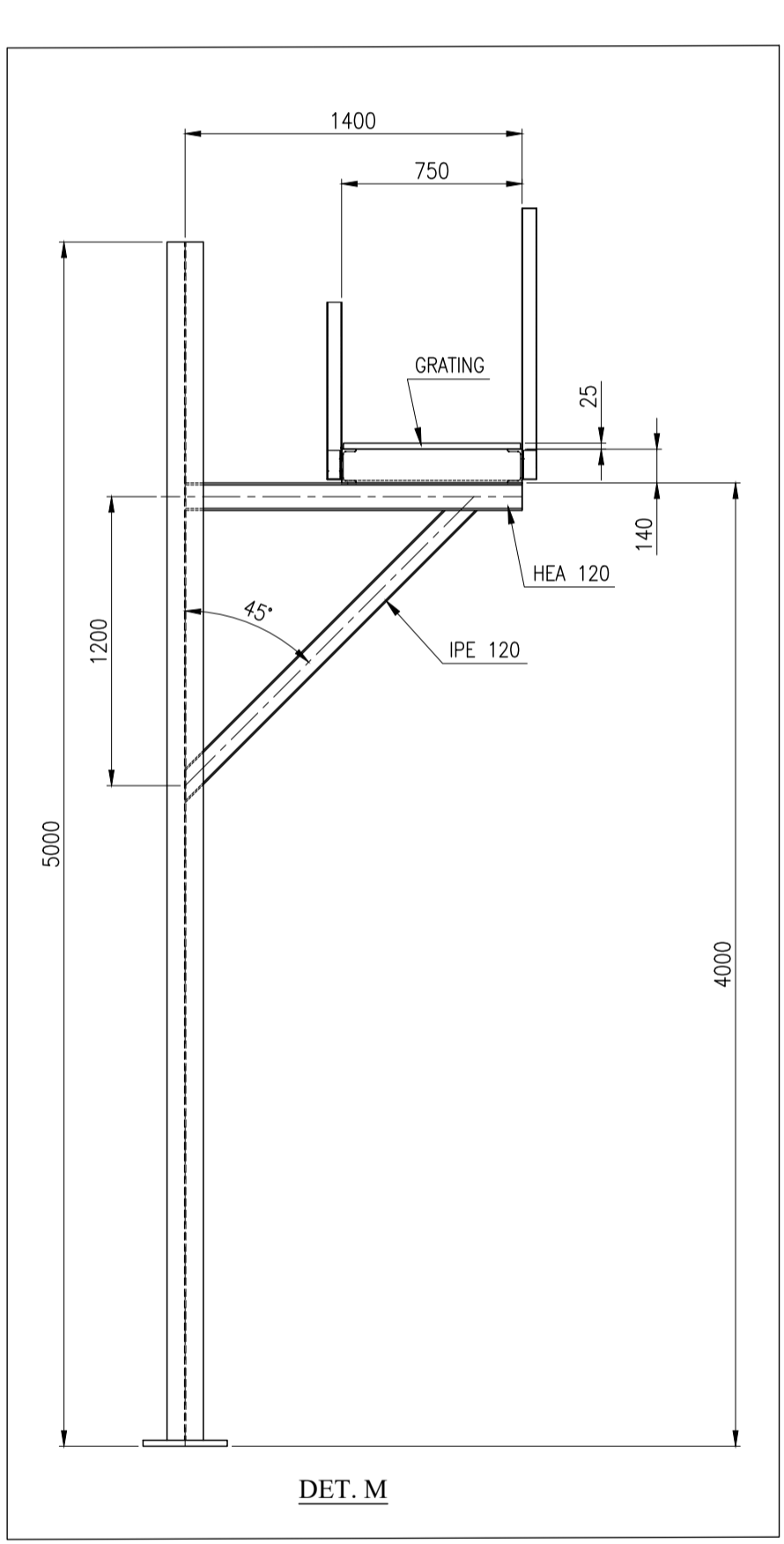

DET. M

Table 1. Weight of equipments For 1 Units (Total Units = 2)

	Total No in one Unit	Unit Weight (tonf)	Total No. for One Bay	Weight for One Bay (kgf)
Bundle Frame	1	1.091	1	1091
Tube Bundle & Headers	1	2.922	1	2922
Bundle frame & tube bundle(DRY)	1	4.013	1	4013
Bundle frame & tube bundle (OP)	1	4.222	1	4222
Bundle frame & tube bundle(HYD)	1	4.493	1	4493
Water in Tubes & Headers	1	0.48	1	480
Plenum	2	0.262	2	524
Fan Ring	2	0.13	2	260
Motor	2	0.07	2	140
Fan	2	0.0275	2	55
Speed Reducer	2	0.25	2	500
Machinery Mount	2	0.32	2	640
Fan Guard	2	0.0325	2	65
sum				2184
Fabrication Weight For 1 Units				11167
Operation Weight For 1 Units				11376
Hydrotest Weight For 1 Units				11647
Total Weight of Main structure, Ladder for 1 Units				4970

TABLE: Joint Reactions				
Joint Text	Output Case	Fx Kgf	Fy Kgf	Fz Kgf
A-1	DEAD	16.65	-45	861.98
A-1	DEAD	49.34	-158.83	1640.14
A-1	DEAD_OP	4.08	-14.37	92.37
A-1	DEAD_N	-1631.93	429.16	-2881.5
A-1	LIVE	3.34	25.54	1383.73
A-1	WX	31.57	329.34	352.72
A-1	WY	-387.76	93.94	-669.09
A-1	SNOW	9.74	-24.99	547.61
A-1	EQX	106.43	1146.34	-1764.17
A-1	EQY	-1561.76	337	-3289.21
A-1	EQO	210.24	2295.43	-353.83
A-1	EQVO	-3123.79	673.24	-6571.39
A-2	DEAD	-20.6	1.599E-13	380.54
A-2	DEAD	-33.06	-0.00000289	811.07
A-2	DEAD_OP	-0.21	-3.963E-07	35.27
A-2	DEAD_N	10.59	-1.13	-378.95
A-2	LIVE	-76.47	6.353E-13	402.18
A-2	WX	1.165E-12	49.87	8.288E-13
A-2	WY	-54.91	-1.269E-13	-353.83
A-2	SNOW	-19.58	-8.653E-07	221.21
A-2	EQX	0.004107	45.8	0.09216
A-2	EQY	-48.82	-0.38	-1465.12
A-2	EQO	0.00889	92.7	0.18
A-2	EQVO	-98.54	-0.78	-2927.34
A-3	DEAD	16.65	45	861.98
A-3	DEAD	49.34	158.83	1640.17
A-3	DEAD_OP	4.08	14.37	92.37
A-3	DEAD_N	39.17	235.02	482.86
A-3	LIVE	3.34	-25.54	1383.73
A-3	WX	-31.57	329.34	352.72
A-3	WY	-387.76	-93.94	-669.09
A-3	SNOW	9.74	24.99	547.61
A-3	EQX	-106.49	1146.49	1764.07
A-3	EQY	-1071.77	-428.48	-2570.23
A-3	EQO	-210.36	2295.75	3529.6
A-3	EQVO	-2144	-896.2	-5134.3
B-1	DEAD	34.11	-3.44	482.68
B-1	DEAD	174.23	-2.24	983.92
B-1	DEAD_OP	16.3	0.03128	81.45
B-1	DEAD_N	670.87	1.33	2555.04
B-1	LIVE	-43.74	-6.51	64.14
B-1	WX	-255.25	0.99	-374.63
B-1	WY	-1.33	-70.96	504.74
B-1	SNOW	24.65	-1.56	193.87
B-1	EQX	-985.73	4.1	-1834.5
B-1	EQY	-51.12	-28.6	2619.38
B-1	EQO	-1968.03	8.38	-3558.39
B-1	EQVO	-102.38	-57.85	5233.15
B-2	DEAD	-3.76E-15	-9.82	342.79
B-2	DEAD	-1.168E-10	-61.15	847.79
B-2	DEAD_OP	-1.602E-11	-8.01	77.09
B-2	DEAD_N	-0.0003857	-403.24	720.08
B-2	LIVE	8.844E-15	82.81	-147.91
B-2	WX	-56.07	3.583E-12	-6.399E-12
B-2	WY	-8.004E-14	-439.42	682.53
B-2	SNOW	-3.498E-11	3.21	131.34
B-2	EQX	0.02819	0.04229	-0.07544
B-2	EQY	0.006383	-1570.51	2804.88
B-2	EQO	0.2	0.08416	-0.15
B-2	EQVO	0.0007535	-3138.25	5603.81
B-3	DEAD	-34.11	-1.44	482.68
B-3	DEAD	-174.23	-2.24	983.9
B-3	DEAD_OP	-16.3	0.03128	81.45
B-3	DEAD_N	-670.07	1.26	1104.47
B-3	LIVE	43.74	-6.51	64.14
B-3	WX	-255.25	-0.99	374.63
B-3	WY	1.33	-70.96	504.74
B-3	SNOW	-24.65	-1.56	193.87
B-3	EQX	-985.73	-4.09	1834.58
B-3	EQY	-40.75	-28.68	1909.29
B-3	EQO	-1968.16	-8.15	3558.54
B-3	EQVO	-81.36	-57.83	3796.07

GENERAL DATA	
ITEM NO.	-
DESIGN CODE BUNDLE/STRUCTURE	ASME SEC.VIII DIV.1(2019), API 661-7th EDITION R2018
INLET PRESSURE/PRESSURE DRG. (ALLOWABLE/CALC)	19.8 Bar / (0.1/0.016) Bar
DESIGN PRESSURE	22+F.V. (barg)
HYDROSTATIC TEST PRESSURE	28.6 (bar)
TEMPERATURE IN/OUT(TUBE SIDE)	73.5°C/56.3°C
DESIGN TEMPERATURE	120 °C
MINIMUM DESIGN METAL TEMPERATURE	-45°C
AIR INLET/OUTLET TEMPERATURE (AIR SIDE)	48 / 62.28 °C
MINIMUM DESIGN AMBIENT TEMPERATURE	5 °C
CORROSION ALLOWANCE	3 mm
ULTRASONIC TEST	YES(Full)[See note 8]
RADIOGRAPHY	YES(Full)[See note 8]
STRESS RELIEVING	YES
BARE/FINNED SURFACE PER UNIT	68.101/1579.2 m ²
NUMBER OF BUNDLE PER BAY	1
NUMBER OF UNIT	2
NUMBER OF BAY PER UNIT	1
NOZZLE SIZE(INLET/OUTLET/RATING/TYP)	1x4"/1x2"/SCH.80/#300
PROCESS FLUID NAME	PROPANE
SERVICE	PROPANE
PASSES PER BUNDLE	4
FINNED-TUBES/BUNDLE	NO.140 TUBES OD=25.4 SEAMLESS MIN.W.BWG16,THK=1.65L=6096 mm
Tube to tube sheet joint	STRENGTH WELD + EXPANDED
Fin (Type,material, OD,PPI)	EXTRUDE.AL 1060,57,15.11
STEAM COIL	NO
LOUVER/TYP	NO/-
PLENUM / FAN RING	FORCED TYPE/CONICAL L/D=0.05
VIBRATION SWITCH	YES,(FOR EACHFAN) MANUAL & ELECTRIC RESET,Exd IC T5 Gb,IP65
FAN SPECIFICATION RPM/DIAMETER	362/7 Ft
Pitch angle (for fan)	6.6°
BLADE NO. / MATERIAL	4/ALUMINIUM
AIR QUANTITY FOR FAN	26.879 m ³ /s
STATIC PRESSURE	102.95 Pa
AIR TEMPERATURE IN/OUT	48°C/52.28°C
SPEED REDUCER TYPE	V BELT
REDUCTION RATIO	3.76
MOTOR TYPE	ELECTRIC-Exhb.IIB-T4-IP55
VOLTAGE/Freq./PHASES	400/50/3
RPM/KW	1500/7.5 Kw
Motor VFD per unit	50%
VFD POWER	YES/11 Kw
S.P.L. 1m all side of fan:	<85 dB(A)1m all sides

NOTES:
1) Loading Data
WIND :ASCE7-16,VELOCITY :125Km/h, EXPOSURE : C
Earthquake: Standard No. 2800,A=0.3,B=2.75,I=1.4,R=3.5,SOIL TYPE=IV
2) Fans
-100% AP(Adjustable pitch-manual)
3) Miscellaneous
- The Inlet Header Boxes Are Fixed In The Direction Of Fin Tubes,
Refer To Table For The Lateral Displacement In Y Direction
- Flange Face Detail : ASME ANSI B16.5
4) All Dimensions Are In Millimeter Unless Otherwise Specified.
5) All Dimensions Tolerances Are According to API 661.(Figure 10)
6) Bolts which are used for fixing headers to side frame , on sliding side should be removed after erection.
7) PROTECTION(SEE Galvanizing Specification and Inspection Procedure: E1027-DMF-VD-QC-PRO-024
8) RADIOGRAPHIC TEST (FULL/SPOT) SHALL BE IN COMPLIANCE WITH THE NDT PROCEDURE & WELD/NDT MAP E1027-DMF-VD-QC-PRO-023
9) 50% motors per unit to be VFD.

LOAD DEFINITION*

DEAD	DEAD LOAD(PLENUMS+FAN RINGS+FAN GUARDS+FAN+MOTOR+SPEED REDUCERS+GRATING+TUBE BUNDLE EMPTY)+HEADER WALK WAY
DEAD OP	WEIGHT OF LIQUID WITHIN EACH TUBE BUNDLE& STEAM COIL(WATER)
DEADS	SELF WEIGHT OF STRUCTURE
DEADN	NOZZEL LOAD
LIVE	WALKWAY LOAD 250 Kg/m ²
EQX	SEISMIC LOAD DIR.X
EQY	SEISMIC LOAD DIR.Y
WX	WIND LOAD DIR.X
WY	WIND LOAD DIR.Y
SNOW	66 Kg/m ²

* Further Definition Check the Steel Structure Calculation.Doc No.: E1027-DMF-VD-ST-CAL-004
1158-A01-0030-00

THE MAXIMUM ALLOWABLE MOMENTS AND FORCES PER EACH NOZZLE (IF LOADS ARE DIVIDED EQUALLY FOR NOZZLES ACCORDING TO 3xAPI 661(7.1.10.1)

SIZE	Fx(N)	Fy(N)	Fz(N)	Mx(N.m)	My(N.m)	Mz(N.m)
4"	10020	8010	10020	2430	3660	2430
2"	3060	3990	3060	450	720	450

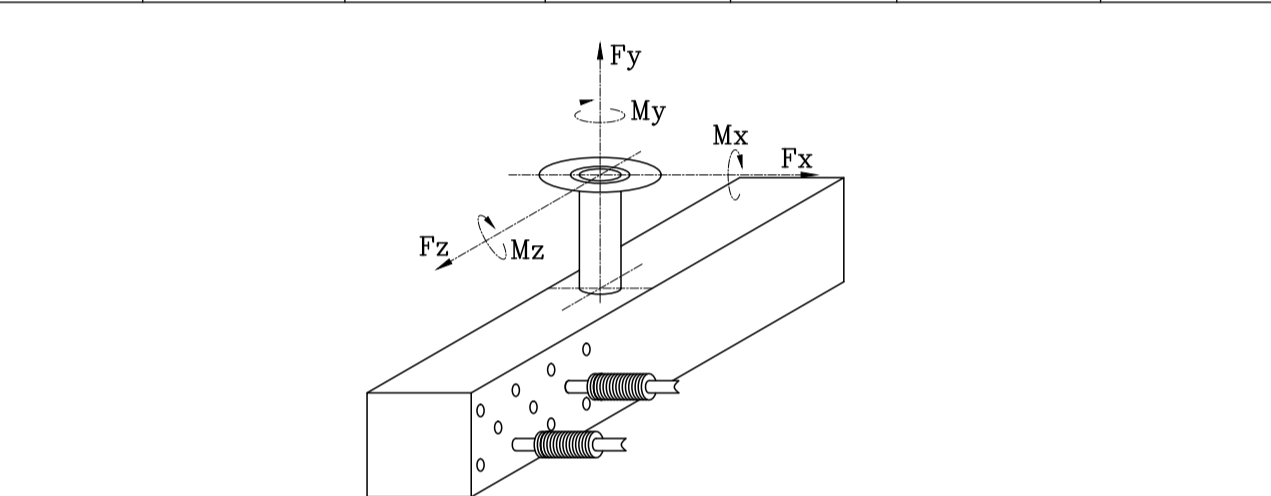

CONNECTIONS				
NO.	REP.	QTY. PER BAY/UNIT	DIA	DESIGNATION
N1	INLET NOZZLE/FLANGE	1/2	4"	FLANGE ANSI B16.5,#300,LWN,RF,SA-350 Q&B /SA-350 LF2 CL1,N,THK=13.49
N2	OUTLET NOZZLE/FLANGE	1/2	2"	FLANGE ANSI B16.5,#300,LWN,RF,SA-350 LF2 CL1,N,THK=16.6
V1&V2	VENT	2/4	1"	FLANGE ANSI B16.5,#300,LWN,RF,SA-350 LF2 CL1,N,THK=14.3
D1&D2	DRAIN	2/4	1"	FLANGE ANSI B16.5,#300,LWN,RF,SA-350 LF2 CL1,N,THK=14.3
1A	VIBRATION SWITCH	2/4	-	SEE FAN DRIVE ASSEMBLY DRAWING
2A	MOTOR(7.5Kw)	2/4	-	SEE FAN DRIVE ASSEMBLY DRAWING
3A	FAN	2/4	7ft	SEE FAN DRIVE ASSEMBLY DRAWING

LATERAL DISPLACEMENT OF HEADERS (DIRECTION X) INSIDE BUNDLE FRAME IN RELATION WITH EXPANSION FORCES ON NOZZLES (mm) (ACCORDING TO API661 7-1-1-2)

MAXIMUM DISPLACEMENT INLET/OUTLET : ±9

* FOR MORE DETAILS FOR EACH COMPONENT OF AIR COOLER REFER TO BELOW DRAWING & DOCUMENTS.

REFERENCED DWG&DOC.			
TITLE	VENDOR DOCUMENT NO.	CLIENT DOCUMENT NO.	
Tube Bundle Drawing	1158-A01-2000-00	E1027-DMF-VD-ME-DWG-005	
Bundle Frame Drawing	1158-A01-2400-00	E1027-DMF-VD-ME-DWG-007	
Fan Drive Assembly Drawing	1158-A01-5087-00	E1027-DMF-VD-ME-DWG-008	
Fan Ring Drawing	1158-A01-5167-00	E1027-DMF-VD-ME-DWG-009	
Support Mechanism Drawing	1158-A01-6307-00	E1027-DMF-VD-ME-DWG-010	
Plenum Drawing	1158-A01-5110-00	E1027-DMF-VD-ME-DWG-011	
Steel Structure Drawing	1158-A01-1100-00	E1027-DMF-VD-ST-DWG-013	
Header Walkway Drawing	1158-A01-1200-00	E1027-DMF-VD-ST-DWG-014	
Ladder Drawing	1158-A01-1520-00	E1027-DMF-VD-ST-DWG-015	
Surface Preparation and Painting Procedure for Air Cooler	1158-A01-GS01-00	E1027-DMF-VD-QC-PRO-024	

R#	DATE	DESCRIPTION	F.SZ	J.M.	J.B.L	A.GHZ
R8	04/08/2025	ISSUED FOR APPROVAL	F.SZ	J.M.	J.B.L	A.GHZ
R7	12/30/2024	ISSUED FOR APPROVAL	F.SZ	J.M.	J.B.L	A.GHZ
R6	12/28/2024	ISSUED FOR APPROVAL	F.SZ	J.M.	J.B.L	A.GHZ
R5	11/13/2024	ISSUED FOR APPROVAL	F.SZ	J.M.	J.B.L	A.GHZ
R4	09/22/2024	ISSUED FOR APPROVAL	F.SZ	J.M.	J.B.L	A.GHZ
R3	08/21/2024	ISSUED FOR APPROVAL	F.SZ	J.M.	J.B.L	A.GHZ
R2	08/10/2024	ISSUED FOR APPROVAL	F.SZ	J.M.	J.B.L	A.GHZ
R1	07/22/2024	ISSUED FOR APPROVAL	F.SZ	J.M.	J.B.L	A.GHZ
REV	06/30/2024	ISSUED FOR APPROVAL	F.SZ	J.M.	J.B.L	A.GHZ

CLIENT: **ENBR TEKNOLOJI**

CONTRACTOR: **dt Damafin thermal technology**

PROJECT :
AIR COOLER FOR
Toase-che Park Sanati Gohar Ofogh Petrochemical Co.
General Arrangement Drawing
1158-A01-1000-00
(Sheet 1 of 2)

DWG. NO. E1027-DMF-VD-ME-DWG-003
SCALE: N.T.S. SIZE: A1 REV.: R8
Factory : Km 14 special Karaj road

THIS DOCUMENT IS A CONFIDENTIAL NATURE IS THE PROPERTY OF DAMAFIN AND SHALL NOT BE REPRODUCED IN ANY MANNER, NOR USED FOR ANY PURPOSE WHATSOEVER, EXCEPT BY WRITTEN PERMISSION OF DAMAFIN.

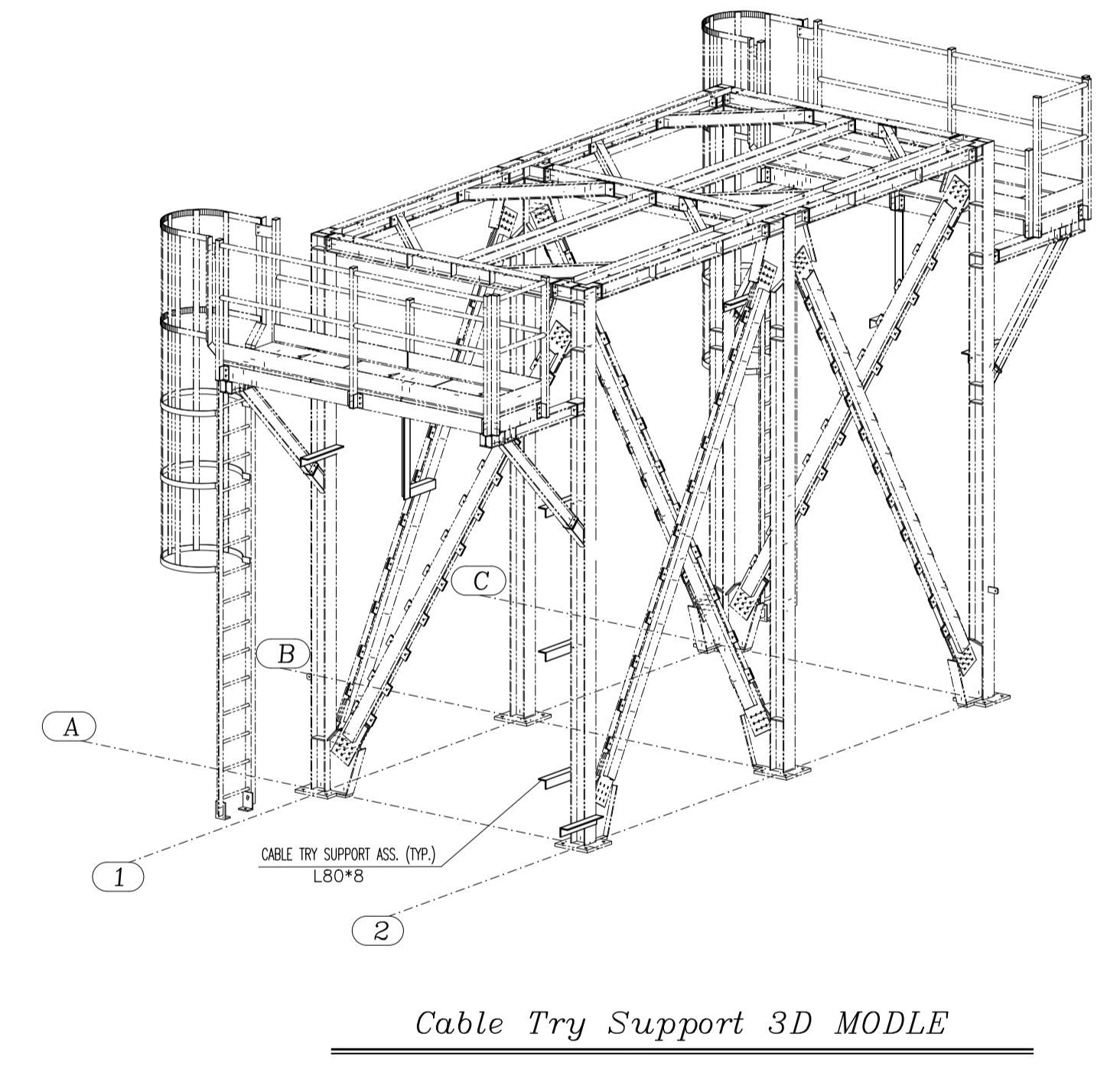
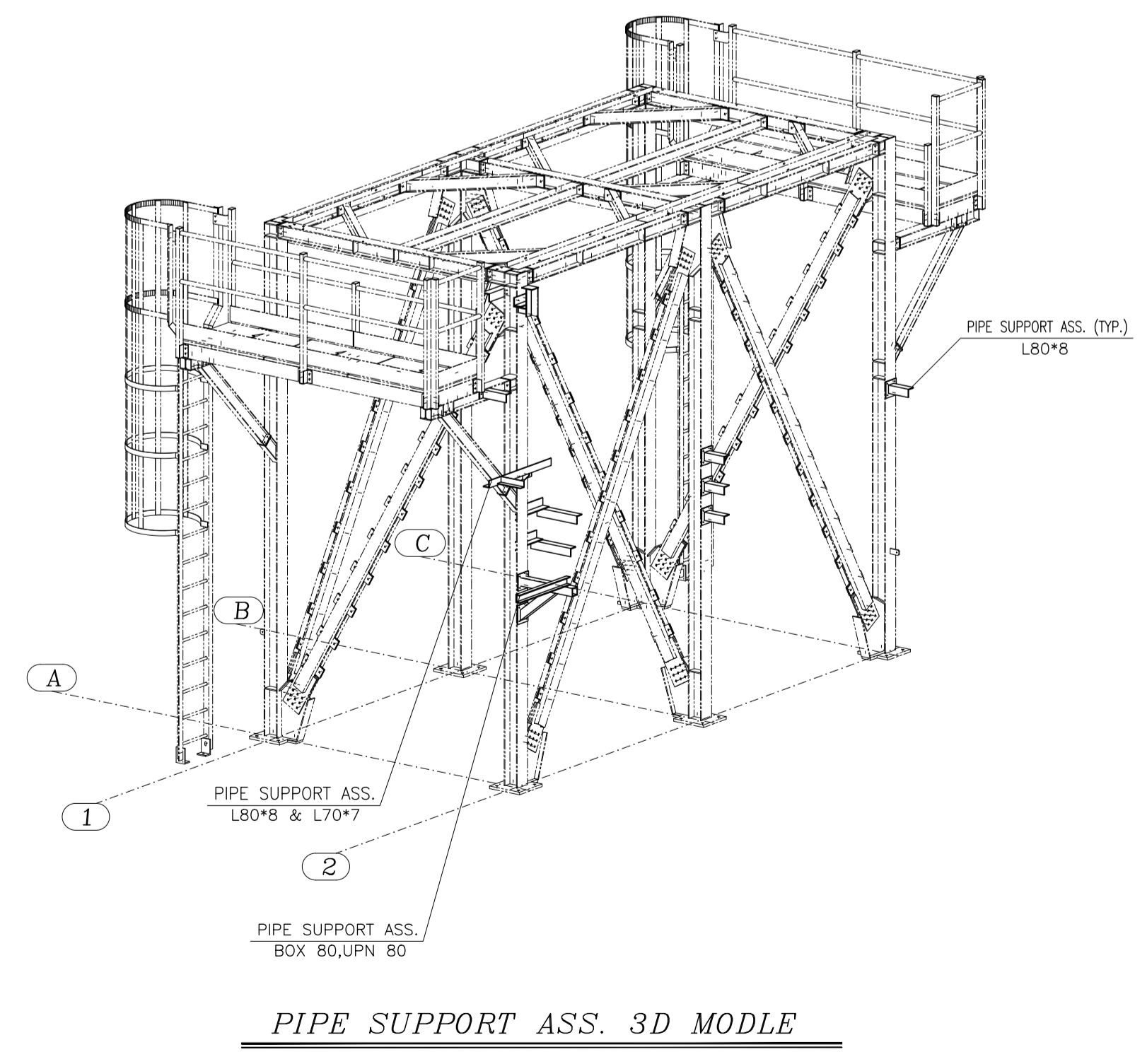
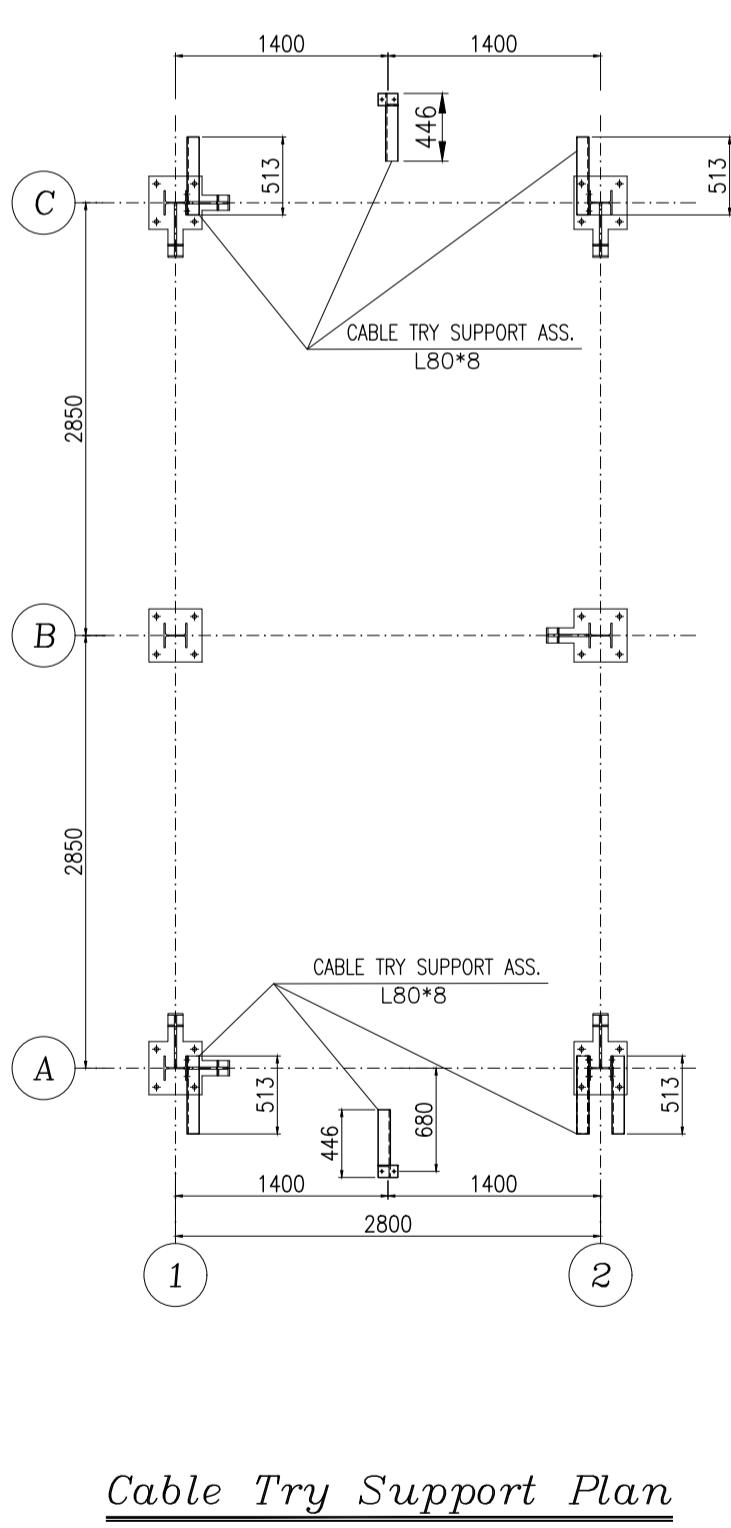
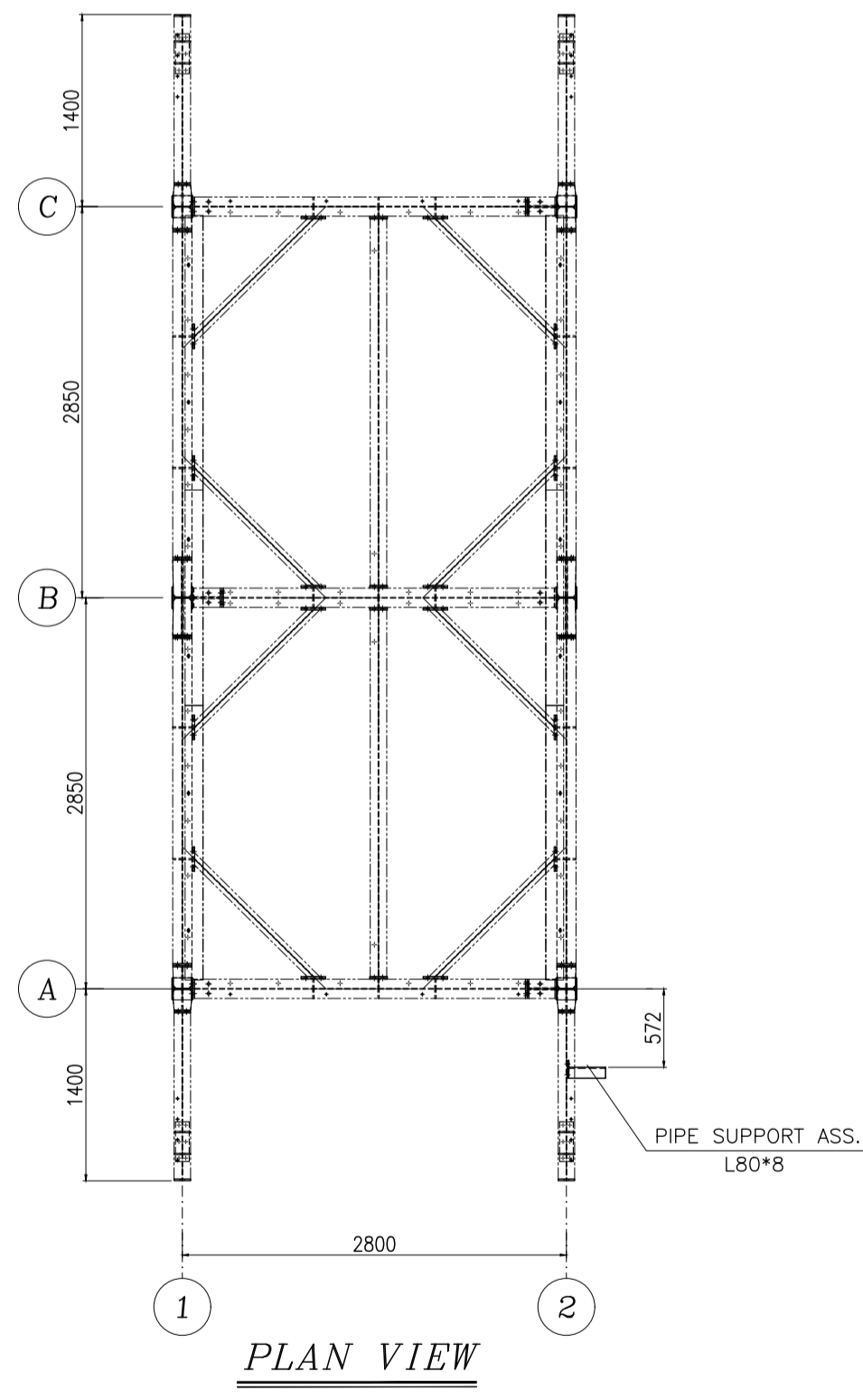
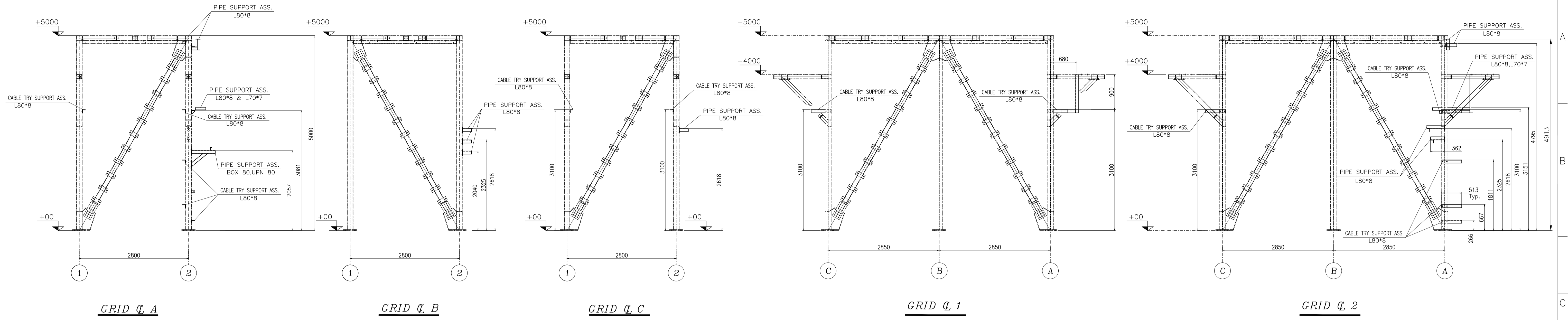

REV	DATE	DESCRIPTION	DRAWN BY	CHECKED BY	APPROVED BY	FINAL APPROVED BY
R8	04/08/2025	ISSUED FOR APPROVAL	F.SZ	J.M.	J.B.L	A.GHZ
R7	12/30/2024	ISSUED FOR APPROVAL	F.SZ	J.M.	J.B.L	A.GHZ
R6	12/28/2024	ISSUED FOR APPROVAL	F.SZ	J.M.	J.B.L	A.GHZ
R5	11/13/2024	ISSUED FOR APPROVAL	F.SZ	J.M.	J.B.L	A.GHZ

CLIENT: **ENBR TEKNOLOJI**

PROJECT: **AIR COOLER FOR Toase-che Park Sanati Gohar Ofogh Petrochemical Co. General Arrangement Drawing**
 1158-A01-1000-00
 (Sheet 2 of 2)

DWG. NO. **E1027-DMF-VD-ME-DWG-003**

SCALE: N.T.S. SIZE: A1 REV.: R8

CONTRACTOR: **dt Damafin thermal technology**
 Factory : Km 14 special Karaj road

THIS DOCUMENT OF A CONFIDENTIAL NATURE IS THE PROPERTY OF DAMAFIN AND SHALL NOT BE REPRODUCED IN ANY MANNER, NOR USED FOR ANY PURPOSE WHATSOEVER, EXCEPT BY WRITTEN PERMISSION OF DAMAFIN.