

FRONT VIEW  
CL. A.C.

\* THIS DIMENSION WILL BE FINALIZED AFTER APPROVED OF MOTOR DATA SHEET

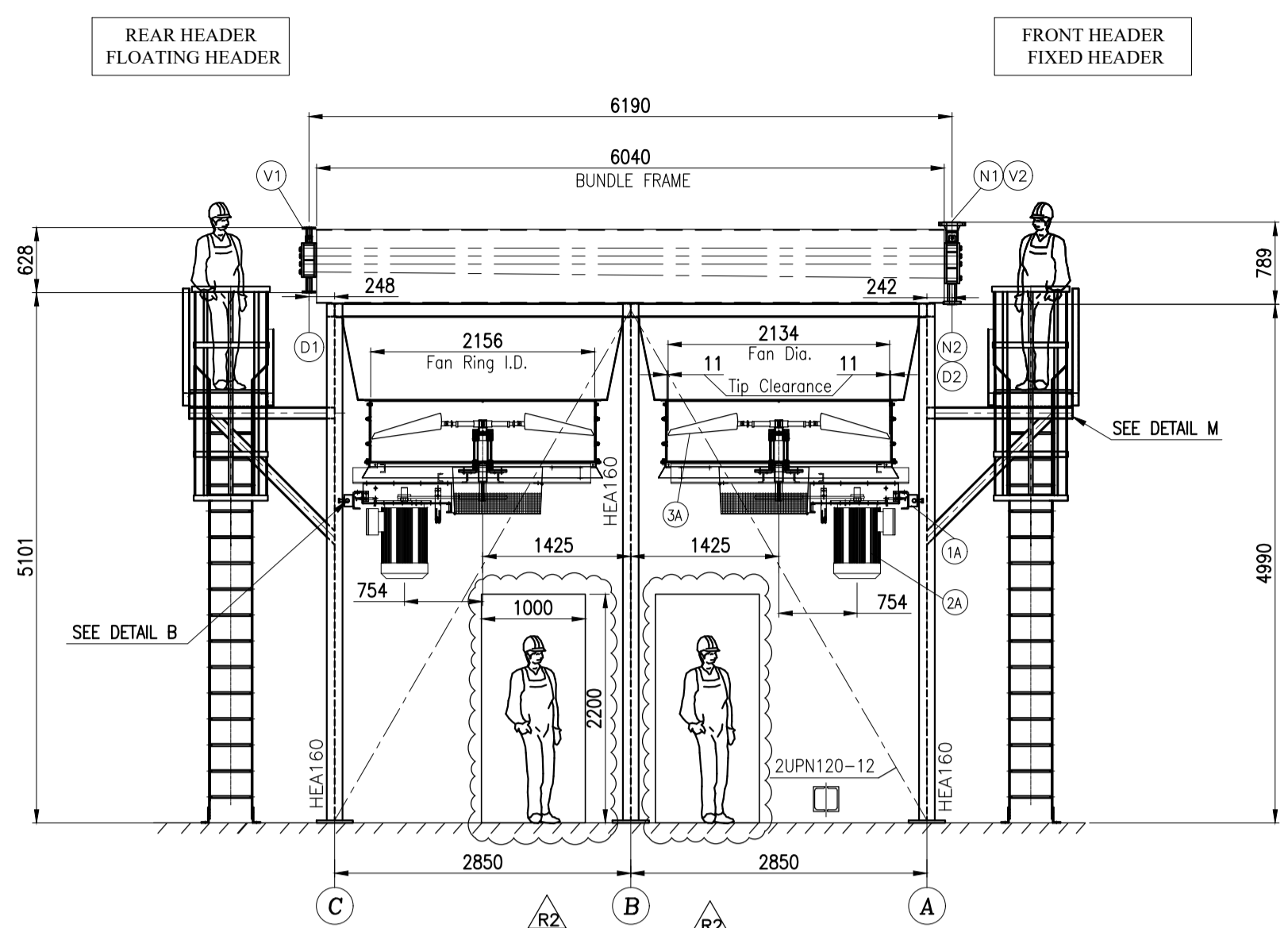

SIDE VIEW

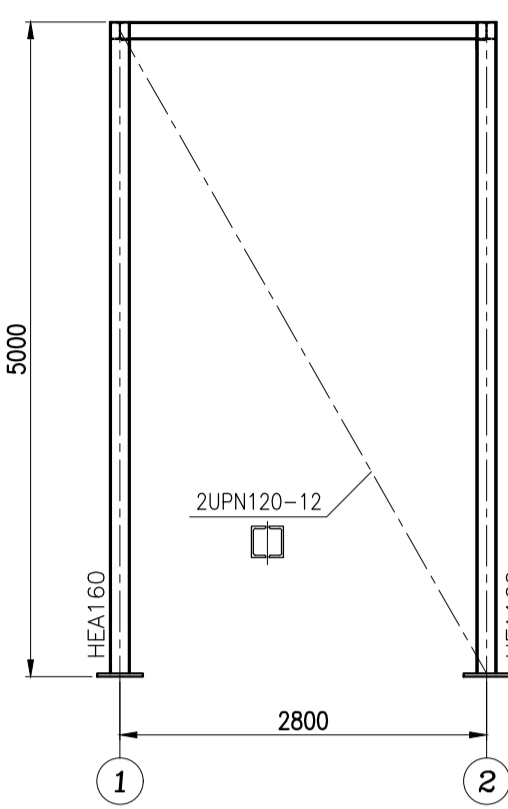

FRONT VIEW  
CL. B

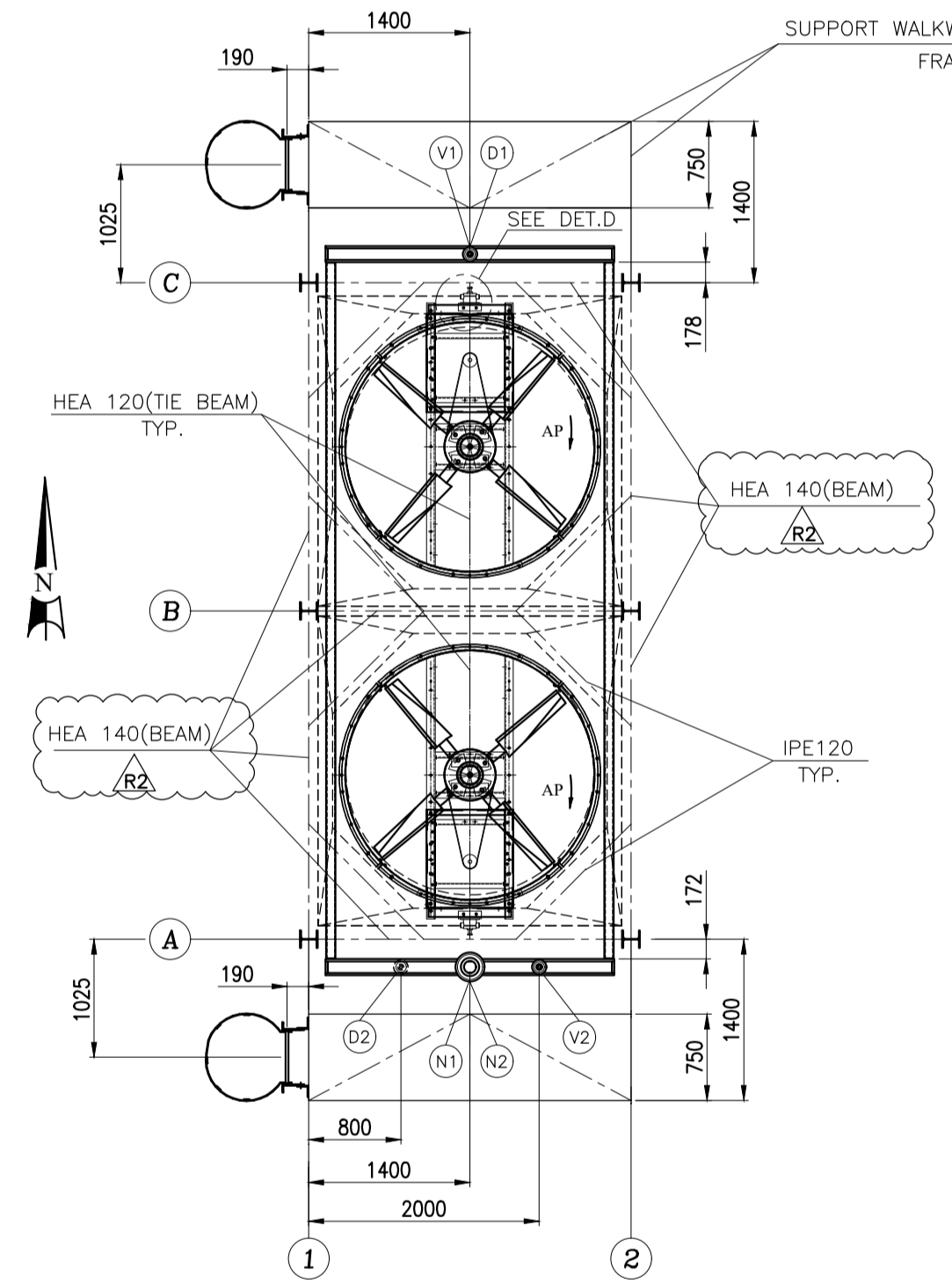

TOP VIEW

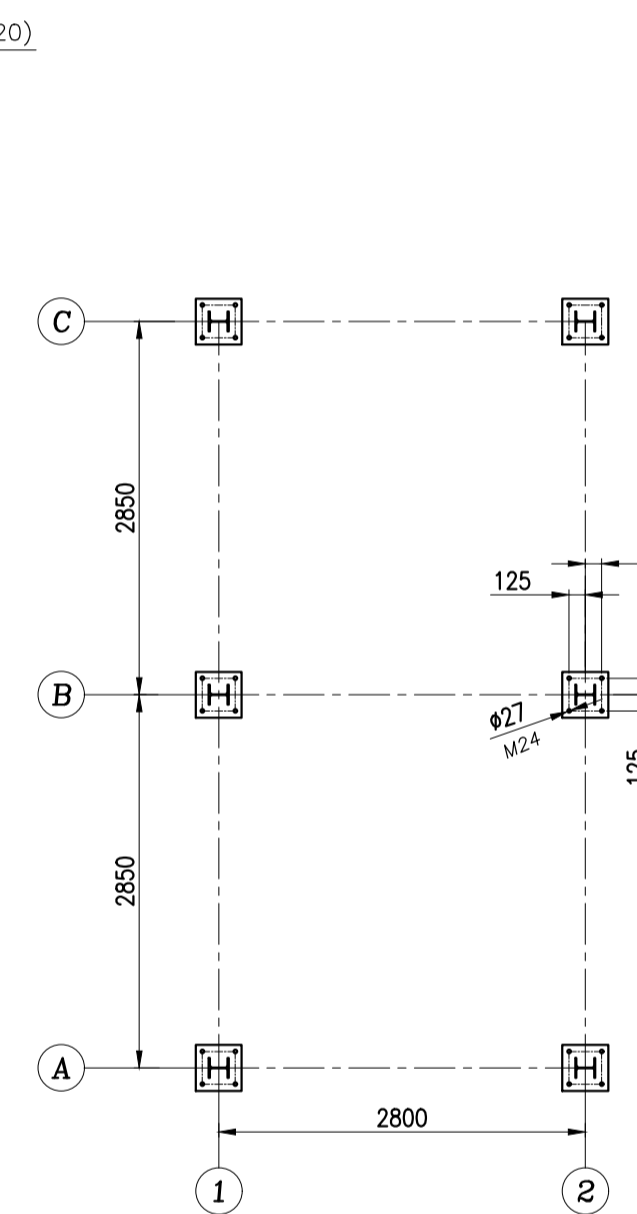

BASE PLATE VIEW

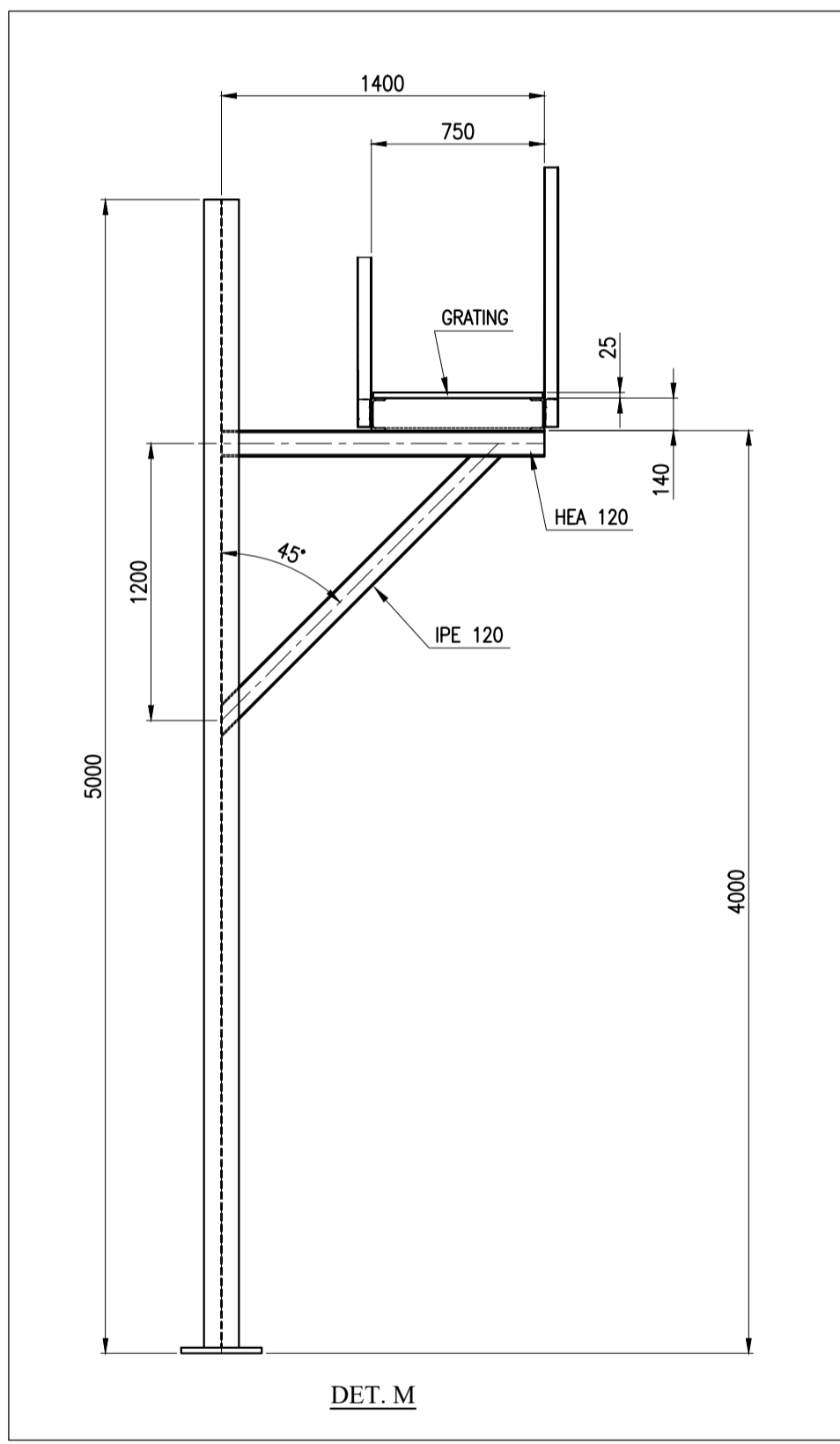

DET. M

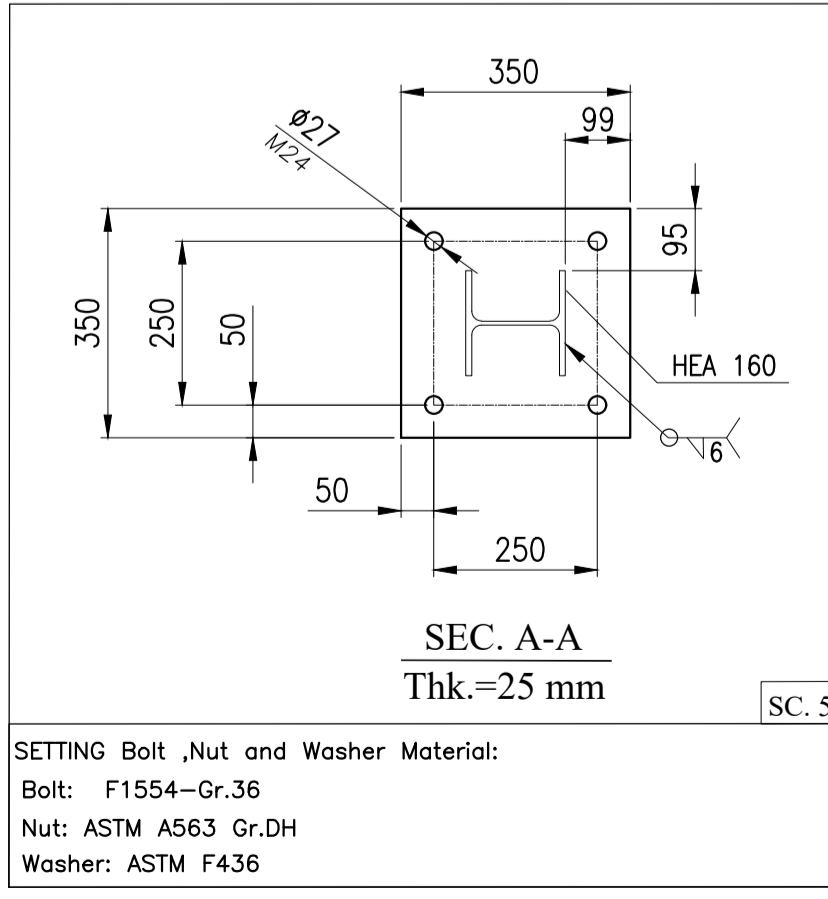

SEC. A-A  
Thk.=25 mm

SETTING Bolt, Nut and Washer Material:  
Bolt: F1554-Gr.36  
Nut: ASTM A563 Gr.DH  
Washer: ASTM F436

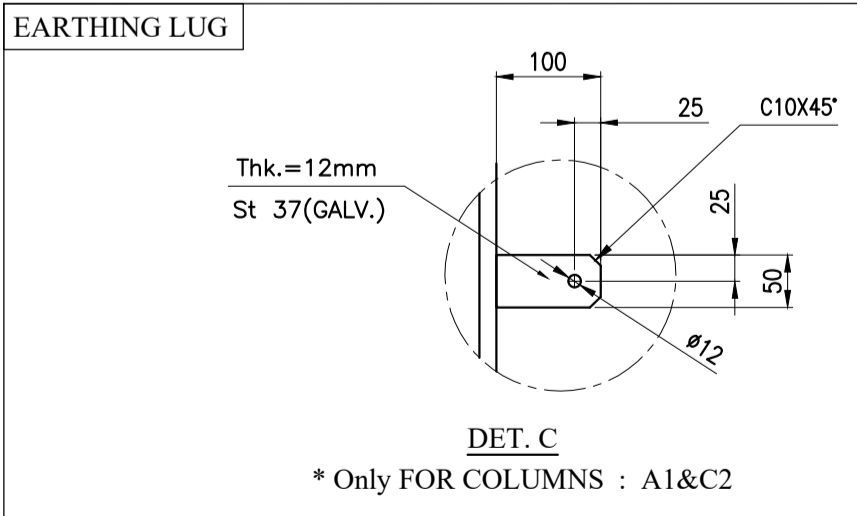

DET. C

\* Only FOR COLUMNS : A1&C2

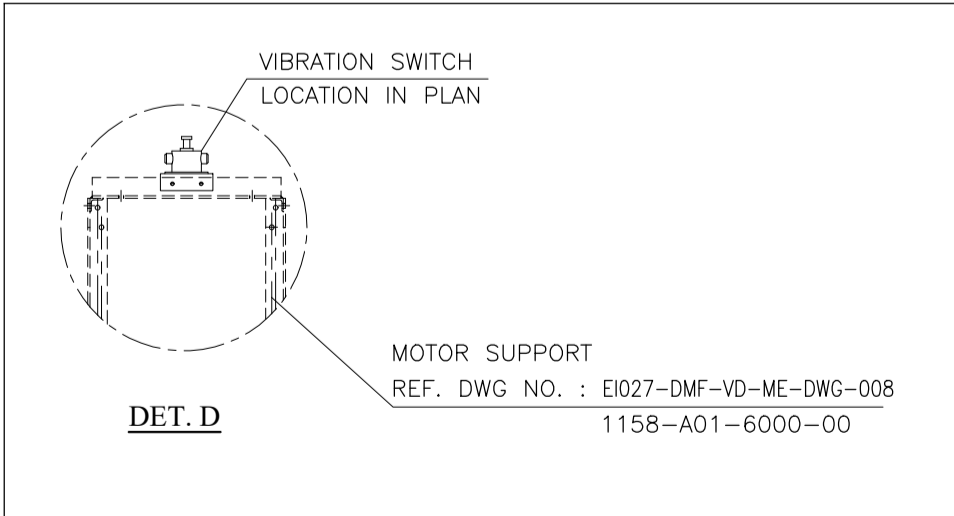

DET. D

REF. DWG NO. : E027-DMF-V0-ME-DWG-008  
1158-A01-6000-00

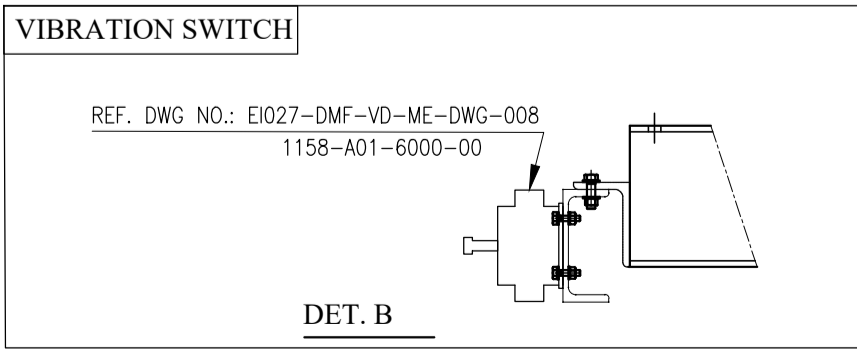

DET. B

Table 1. Weight of equipments For 1 Units (Total Units = 2)

Equipment	Total No in one Unit	Total Weight in one Unit (tonf)	Total No. for One Bay	Weight for One Bay (kgf)
Bundle Frame	1	0.865	1	865
Tube Bundle & Headers	1	2.635	1	2635
sum				<b>3500</b>
Water in Tubes & Headers	1	0.48	1	480
sum				<b>480</b>
Plenum	2	0.245	2	490
Fan Ring	2	0.13	2	260
Motor	2	0.07	2	140
Fan	2	0.0275	2	55
Speed Reducer	2	0.25	2	500
Machinery Mount	2	0.32	2	640
Fan Guard	2	0.0325	2	65
sum				<b>2160</b>
Fabrication Weight For 1 Units				5650
Operation Weight For 1 Units				6130
Motor Weight For 1 Units				6130
Total Weight of Main structure, Ladder for 1 Units				<b>6600</b>

TABLE: Joint Reactions

Joint	OutputCase	Fx	Fy	Fz
A-1	DEAD_S	16.65	-45	861.98
A-1	DEAD	49.34	-158.83	1640.14
A-1	DEAD_OP	4.08	-14.37	92.37
A-1	DEAD_N	-1631.93	429.16	-2881.5
A-1	LIVE	3.34	25.54	1383.73
A-1	WX	31.57	329.34	-352.72
A-1	WY	-387.76	93.94	-669.09
A-1	SNOW	9.74	-24.99	547.61
A-1	EQX	106.43	1146.34	-1764.17
A-1	EQY	-151.76	337	-3289.21
A-1	EQZO	212.24	2295.43	-3529.78
A-1	EQYO	-203.79	673.24	-6571.39
A-2	DEAD_S	-20.6	1.589E-13	380.54
A-2	DEAD	-33.06	-0.0000289	811.07
A-2	DEAD_OP	-0.21	-3.963E-07	55.27
A-2	DEAD_N	-10.59	-1.13	-378.95
A-2	LIVE	-76.47	6.353E-13	402.18
A-2	WX	1.165E-12	49.87	8.288E-13
A-2	WY	-54.91	-1.269E-13	-353.83
A-2	SNOW	-19.58	-8.653E-07	221.21
A-2	EQX	0.004107	45.8	0.09216
A-2	EQY	-48.82	-0.38	-1465.12
A-2	EQZO	0.00889	92.7	0.18
A-2	EQYO	-98.54	-0.78	-2927.34
A-3	DEAD_S	16.65	45	861.98
A-3	DEAD	49.34	158.83	1640.17
A-3	DEAD_OP	4.08	14.37	92.37
A-3	DEAD_N	39.17	235.02	482.86
A-3	LIVE	3.34	-25.54	1383.73
A-3	WX	-31.57	329.34	352.72
A-3	WY	-387.76	-93.94	-669.09
A-3	SNOW	9.74	24.99	547.61
A-3	EQX	-106.49	1146.49	1764.07
A-3	EQY	-1071.77	-428.48	-2570.23
A-3	EQZO	-210.36	2295.75	3529.6
A-3	EQYO	-2144	-856.2	-5134.3
B-1	DEAD_S	34.11	-1.44	482.68
B-1	DEAD	174.23	-2.24	983.92
B-1	DEAD_OP	16.3	0.03128	81.45
B-1	DEAD_N	-670.87	1.33	2555.04
B-1	LIVE	-43.74	-6.51	64.14
B-1	WX	-255.25	0.99	-374.63
B-1	WY	-1.33	-70.96	504.74
B-1	SNOW	24.65	-1.56	193.87
B-1	EQX	-985.73	4.1	-1834.5
B-1	EQY	-51.12	-28.6	2619.38
B-1	EQZO	-1968.03	8.18	-3658.39
B-1	EQYO	-102.38	-57.85	5233.15
B-2	DEAD_S	-3.76E-15	-9.82	342.79
B-2	DEAD	-1.168E-10	61.15	847.79
B-2	DEAD_OP	-1.602E-11	-8.01	77.09
B-2	DEAD_N	-0.0003857	-403.24	720.08
B-2	LIVE	8.844E-15	82.81	-147.91
B-2	WX	-56.07	3.583E-12	6.399E-12
B-2	WY	-8.004E-14	-439.42	682.53
B-2	SNOW	-3.498E-11	3.21	131.34
B-2	EQX	0.02819	0.04229	-0.07544
B-2	EQY	0.006383	-1570.51	2804.88
B-2	EQZO	-0.2	0.08416	-0.15
B-2	EQYO	0.0007535	-3138.25	5603.81
B-3	DEAD_S	-34.11	-1.44	482.68
B-3	DEAD	-174.23	-2.24	983.9
B-3	DEAD_OP	-16.3	0.03128	81.45
B-3	DEAD_N	-670.07	1.26	1104.47
B-3	LIVE	43.74	-6.51	64.14
B-3	WX	-255.25	-0.99	374.63
B-3	WY	1.33	-70.96	504.74
B-3	SNOW	-24.65	-1.56	193.87
B-3	EQX	-985.8	-4.09	1834.58
B-3	EQY	40.75	28.68	1900.29
B-3	EQZO	-1968.16	-8.15	3658.54
B-3	EQYO	-81.36	-57.83	3796.07

NOTES:  
1) Loading Data  
WIND :ASCE7-16,VELOCITY :125Km/h, EXPOSURE : C  
Earthquake: Standard No. 2800,A=0.3,B=2.75,I=1.4,R=3.5,SOIL TYPE=IV  
2) Fans  
-100% AP(Adjustable pitch-manual)  
3) Miscellaneous  
- The Inlet Header Boxes are Fixed In The Direction Of Fin Tubes,  
Refer To Table For The Lateral Displacement In Y Direction  
- Flange Face Detail : ASME ANSI B16.5  
4) All Dimensions Are In Millimeter Unless Otherwise Specified.  
5) All Dimensions Tolerances Are According to API 661.(Figure 10)  
6) Bolts which are used for fixing headers to side frame , on sliding side should be removed after erection.  
7) PROTECTION(SEE Galvanizing Specification and Inspection Procedure: EIO27-DMF-V0-QC-PRO-024  
8) RADIOGRAPHIC TEST (FULL/SPOT) SHALL BE IN COMPLIANCE WITH THE REQUIREMENTS OFNASME SEC. VIII DIV.1 UW-11 & UW-12.

LOAD DEFINITION \*

LOAD	DEFINITION
DEAD	DEAD LOAD(PLENUMS+FAN RINGS+FAN GUARDS+FAN+MOTOR+SPEED REDUCERS+GRATING+TUBE BUNDLE EMPTY)+HEADER WALK WAY
DEAD OP	WEIGHT OF LIQUID WITHIN EACH TUBE BUNDLE& STEAM COIL(WATER)
DEADS	SELF WEIGHT OF STRUCTURE
DEADN	NOZZEL LOAD
LIVE	WALKWAY LOAD 250 Kg/m2
EQX	SEISMIC LOAD DIR.X
EQY	SEISMIC LOAD DIR.Y
WX	WIND LOAD DIR.X
WY	WIND LOAD DIR.Y
SNOW	66 Kg/m2

\* Further Definition Check the Steel Structure Calculation.Doc No.: EIO27-DMF-V0-ST-CAL-004  
1158-A01-0030-00

THE MAXIMUM ALLOWABLE MOMENTS AND FORCES PER EACH NOZZLE (IF LOADS ARE DIVIDED EQUALLY FOR NOZZLES ACCORDING TO 3xAPI 661(7.1.10.1))

SIZE	Fx(N)	Fy(N)	Fz(N)	Mx(N.m)	My(N.m)	Mz(N.m)
4"	10020	8010	10020	2430	3660	2430
2"	3060	3990	3060	450	720	450

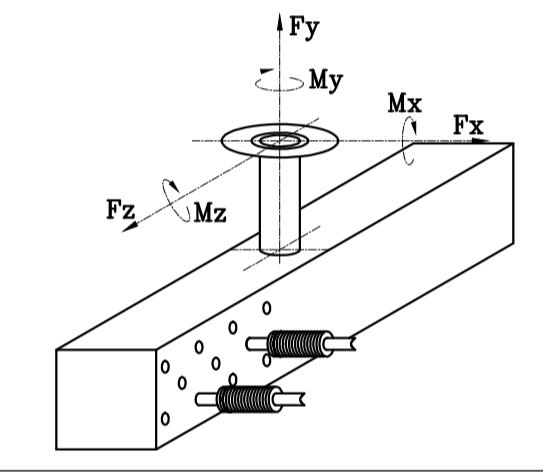

CONNECTIONS

NO.	REP.	QTY. PER BAY/UNIT	DIA	DESIGNATION
N1	INLET NOZZLE/FLANGE	1/2	4"	FLANGE ANSI B16.5,#300,LWN,RF,SCH.160,SA-333 Gr.6 /SA-350 LF2 CL.1N
N2	OUTLET NOZZLE/FLANGE	1/2	2"	FLANGE ANSI B16.5,#300,LWN,RF,SA-350 LF2 CL.1N
V1&V2	VENT	2/4	1"	FLANGE ANSI B16.5,#300,LWN,SA-350 LF2 CL.1 N
D1&D2	DRAIN	2/4	1"	FLANGE ANSI B16.5,#300,LWN,SA-350 LF2 CL.1 N
1A	VIBRATION SWITCH	2/4	-	SEE FAN DRIVE ASSEMBLY DRAWING
2A	MOTOR(7.5Kw)	2/4	-	SEE FAN DRIVE ASSEMBLY DRAWING
3A	FAN	2/4	7ft	SEE FAN DRIVE ASSEMBLY DRAWING

LATERAL DISPLACEMENT OF HEADERS (DIRECTION X) INSIDE BUNDLE FRAME IN RELATION WITH EXPANSION FORCES ON NOZZLES (mm) (ACCORDING TO API661 7-1-1-2) MAXIMUM DISPLACEMENT INLET/OUTLET : ±9

\* FOR MORE DETAILS FOR EACH COMPONENT OF AIR COOLER REFER TO BELOW DRAWING & DOCUMENTS.

REFERENCED DWG&DOC.

TITLE	VENDOR DOCUMENT NO.	CLIENT DOCUMENT NO.
Tube Bundle Drawing	1158-A01-2000-00	E027-DMF-V0-ME-DWG-005
Bundle Frame Drawing	1158-A01-2400-00	E027-DMF-V0-ME-DWG-007
Fan Drive Assembly Drawing	1158-A01-6000-00	E027-DMF-V0-ME-DWG-008
Fan Ring Drawing	1158-A01-5000-00	E027-DMF-V0-ME-DWG-009
Support Mechanism Drawing	1158-A01-5100-00	E027-DMF-V0-ME-DWG-010
Plenum Drawing	1158-A01-5110-00	E027-DMF-V0-ME-DWG-011
Steel Structure Drawing	1158-A01-1100-00	E027-DMF-V0-ST-DWG-013
Header Walkway Drawing	1158-A01-1200-00	E027-DMF-V0-ST-DWG-014
Ladder Drawing	1158-A01-1520-00	E027-DMF-V0-ST-DWG-015
Surface Preparation and Painting Procedure for Air Cooler	1158-A01-GS01-00	E027-DMF-V0-QC-PRO-024

REV	DATE	DESCRIPTION	DRAWN BY	CHECKED BY	APPROVED BY	FINAL APPROVED BY
R2	08/10/2024	ISSUED FOR APPROVAL	F.SZ	J.M.	J.B.L	A.GHZ
R1	07/22/2024	ISSUED FOR APPROVAL	F.SZ	J.M.	J.B.L	A.GHZ
R0	06/30/2024	ISSUED FOR APPROVAL	F.SZ	J.M.	J.B.L	A.GHZ

CLIENT: ENBR TEKNOLOJI

CONTRACTOR: dt Damafin thermal technology

PROJECT: AIR COOLER FOR Toase-che Park Sanati Gohar Ofogh Petrochemical Co.

General Arrangement Drawing  
1158-A01-1000-00

DWG. NO. EIO27-DMF-V0-ME-DWG-003  
SCALE: N.T.S. SIZE: A1 REV.: R2

Factory : Km 14 special Karaj road

THIS DOCUMENT IS A CONFIDENTIAL NATURE IS THE PROPERTY OF DAMAFIN AND SHALL NOT BE REPRODUCED IN ANY MANNER, NOR USED FOR ANY PURPOSE WHATSOEVER, EXCEPT BY WRITTEN PERMISSION OF DAMAFIN.