



Toase-ehe Park Sanati Gohar Ofogh
Petrochemical Co.
**CONCEPTUAL, BASIC and DETAIL DESIGN
ENGINEERING OF STYRENE PARK OFFSITE**



Document Title: General Arrangement Drawing

Document No.: EI027-HSE-VD -PI-DWG-001- R1

Rev. R1

Page 1 of 12

STYRENE PARK OFFSITE

Document Title:
General Arrangement Drawing

Rev.	Issued Date	DESCRIPTION	PREPARED	CHECKED	APPROVED
R1	07-11-2024	IFA	F.sh	M.O	A.M
R0	18-04-2024	IFA	F.sh	M.O	A.M



Toase-e Park Sanati Gohar Ofogh
Petrochemical Co.
**CONCEPTUAL, BASIC and DETAIL DESIGN
ENGINEERING OF STYRENE PARK OFFSITE**



Document Title: General Arrangement Drawing

Document No.: EI027-HSE-VD –PI–DWG–001- R1

Rev. R1

Page 2 of 12

REVISION RECORD SHEET

Page Page	Revisions							Page	Revisions						
	R0	R1	R2	R3	R4	R5	R6		R0	R1	R2	R3	R4	R5	R6
1	X	X						41							
2	X	X						42							
3	X	X						43							
4	X	X						44							
5	X	X						45							
6	X	X						46							
7	X	X						47							
8	X	X						48							
9		X						49							
10		X						50							
11		X						51							
12		X						52							
13								53							
14								54							
15								55							
16								56							
17								57							
18								58							
19								59							
20								60							
21								61							
22								62							
23								63							
24								64							
25								65							
26								66							
27								67							
28								68							
29								69							
30								70							
31								71							
32								72							
33								73							
34								74							
35								75							
36								76							
37								77							
38								78							
39								79							
40								80							

CONNECTION LIST

NO.	LOCATION	DESCRIPTION	SIZE
T-1	VESSEL SKID	CHILLER INLET	3"-150 ANSI RF
T-2	VESSEL SKID	CHILLER OUTLET	3"-150 ANSI RF
T-3	VESSEL SKID	FILTER DRYER INLET	1"-300 ANSI RF
T-4	COMPRESSOR SKID	OIL SEPARATOR PSV	1 1/2"-300 ANSI RF
T-5	VESSEL SKID	CONDENSER PSV	3"-300 ANSI RF
T-6	VESSEL SKID	CHILLER PSV	3"-300 ANSI RF
T-7	VESSEL SKID	INSTRUMENT AIR SUPPLY	1/2"-150 ANSI RF

WEIGHT	
CONDENSER	5600 KG
VESSEL SKID	7000 KG
COMPRESSOR SKID	3500 KG

- NOTES:
1. ALL DIMENSIONS ARE IN MM.
 2. FOR SKID INSTALLATION, REFER TO INSTRUCTION AND OPERATIONAL MANUAL.
 3. ANCHOR HOLES TOLERANCES ± 0.13 in (± 3.2 mm).
 4. CUSTOMER CONNECTION TOLERANCES: ± 1.00 in (± 25.4 mm).
 5. FLANGES ARE PER ANSI STD PER ASME B16.5.
 6. NON-SKID GRATING UNDER MAINTENANCE AREA IS NOT INCLUDED.
 7. PERSONAL PROTECTION, HEAT AND COLD CONSERVATION HEAT TRACING IS BY OTHER.

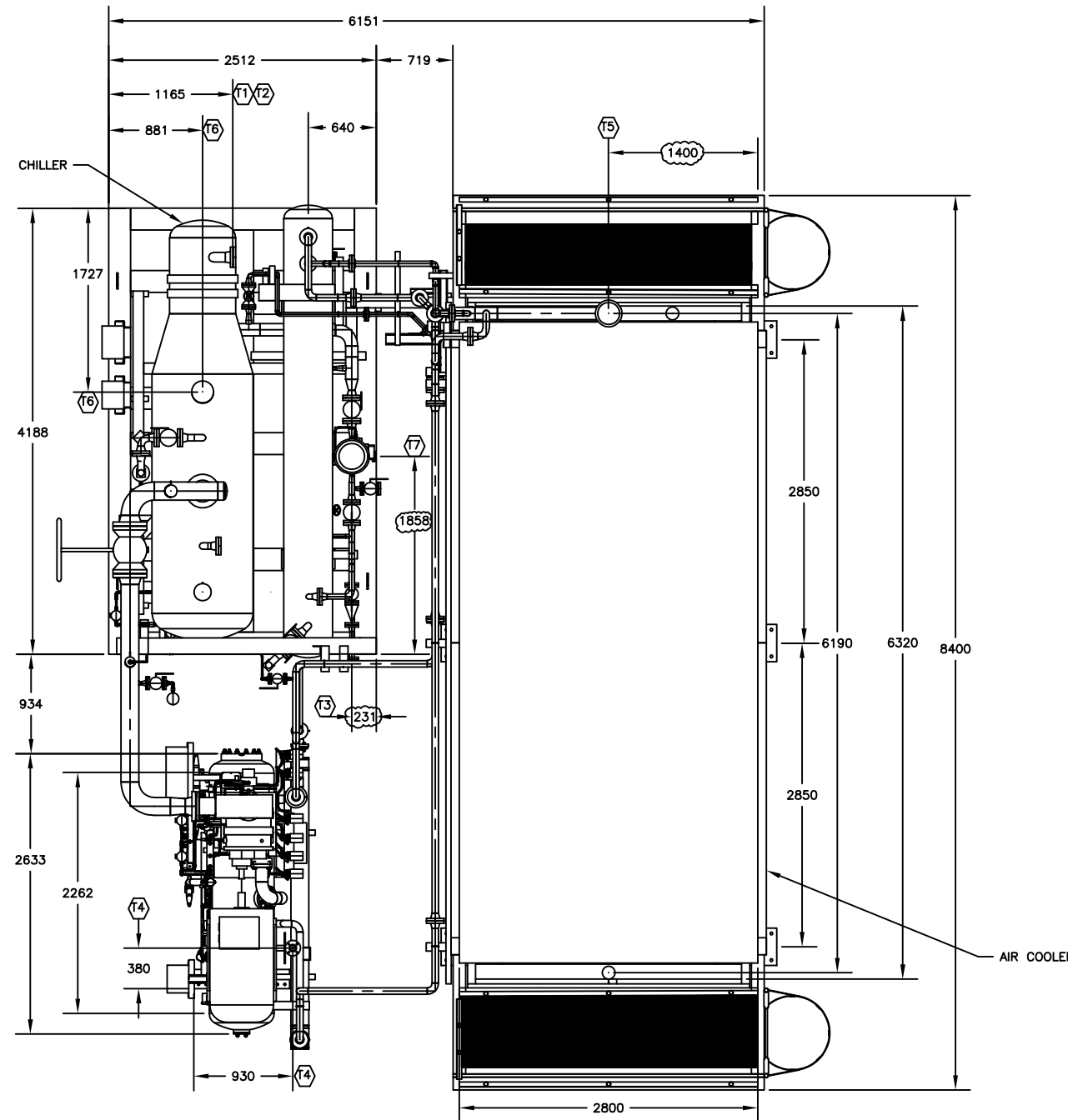
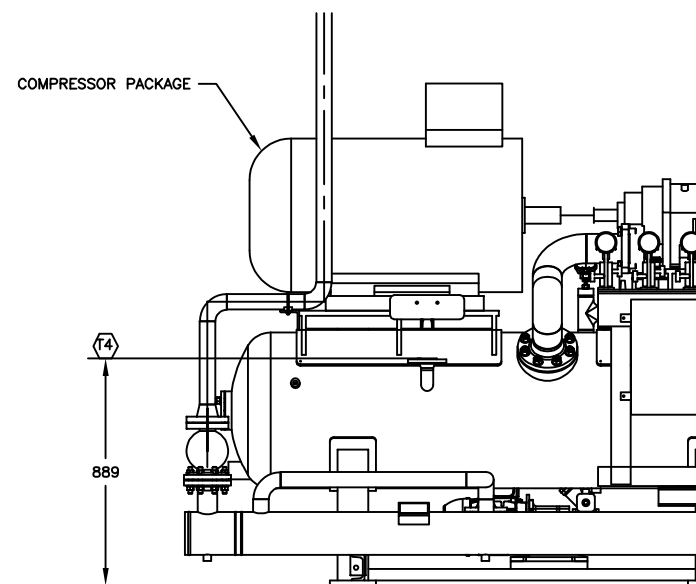
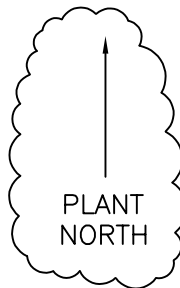

REV.	STATUS	DATE	PURPOSE OF ISSUE	PREP.	CHKD.	APPD.	AUTH.
5	F	31.10.24	FOR APPROVAL	AJD	AJD	IES	SES
4	F	16.09.24	FOR APPROVAL	AJD	AJD	IES	SES
3	F	22.08.24	FOR APPROVAL	AJD	AJD	IES	SES
2	F	22.07.24	FOR APPROVAL	AJD	AJD	IES	SES
1	F	19.07.24	FOR APPROVAL	AJD	AJD	IES	SES
0	F	05.04.24	FOR APPROVAL	AJD	AJD	IES	SES

CLIENT: SERVICE: LOCATION: UNIT TAG NO.:			
VENDOR LOGO			
Contract No.	P.O. No.	SCALE	
DRAWING TITLE: GENERAL ARRANGEMENT DRAWING			
DRAWING NO.	REV.	SHEET No.	SIZE
	5	1 OF 10	D

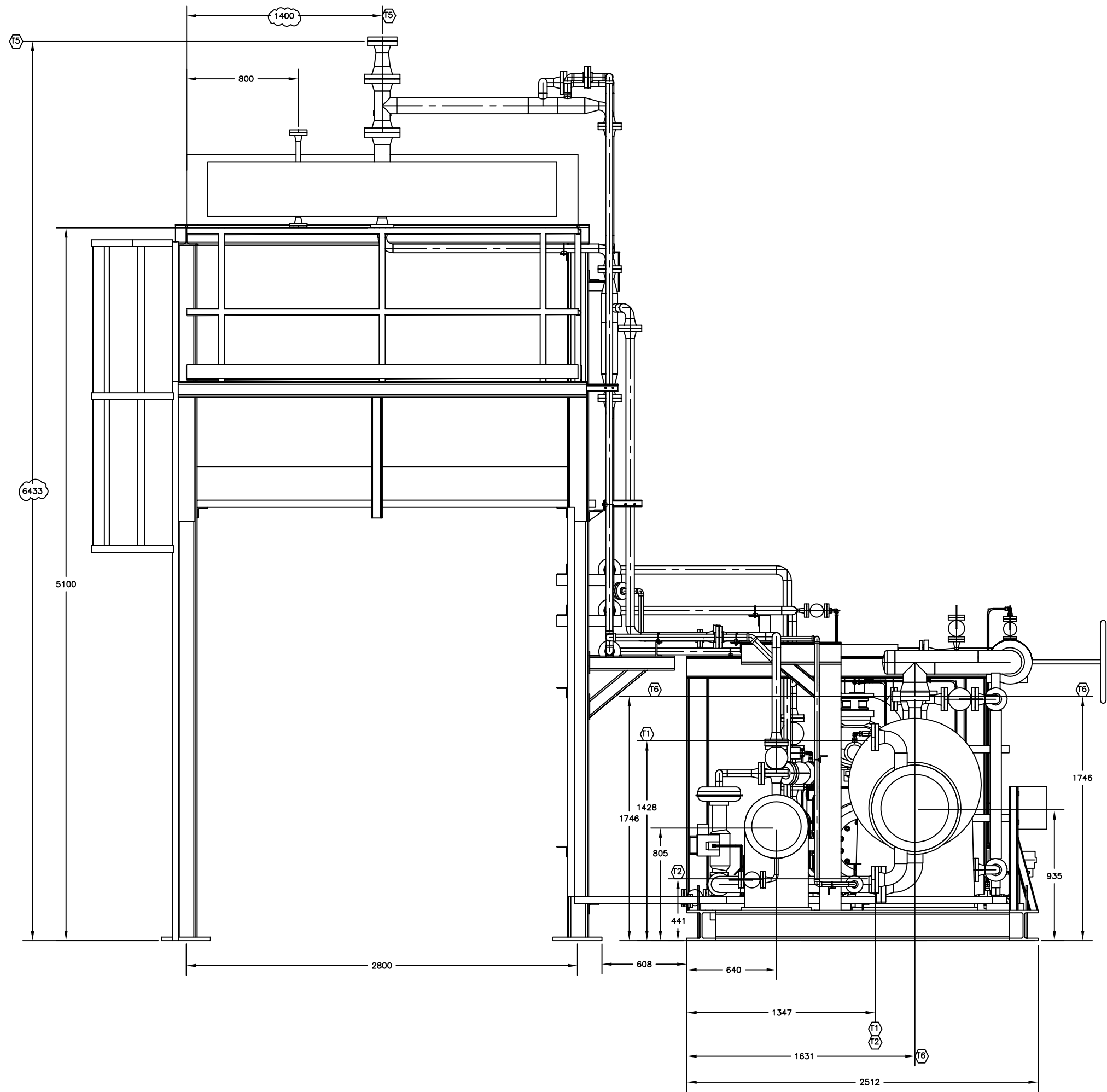

NOTES:
 1. FOR ALL APPLICABLE NOTES, PLEASE REFER TO SHEET 1.

REV.	STATUS	DATE	PURPOSE OF ISSUE	PREP.	CHKD.	APPD.	AUTH.
5	F	31.10.24	FOR APPROVAL	AJD	AJD	IES	SES
4	F	16.09.24	FOR APPROVAL	AJD	AJD	IES	SES
3	F	22.08.24	FOR APPROVAL	AJD	AJD	IES	SES
2	F	22.07.24	FOR APPROVAL	AJD	AJD	IES	SES
1	F	19.07.24	FOR APPROVAL	AJD	AJD	IES	SES
0	F	05.04.24	FOR APPROVAL	AJD	AJD	IES	SES

CLIENT: SERVICE: LOCATION: UNIT TAG NO.:			
VENDOR LOGO			
Contract No.	P.O. No.	SCALE	
DRAWING TITLE: GENERAL ARRANGEMENT DRAWING			
DRAWING NO.	REV.	SHEET No.	SIZE
	5	2 OF 10	D

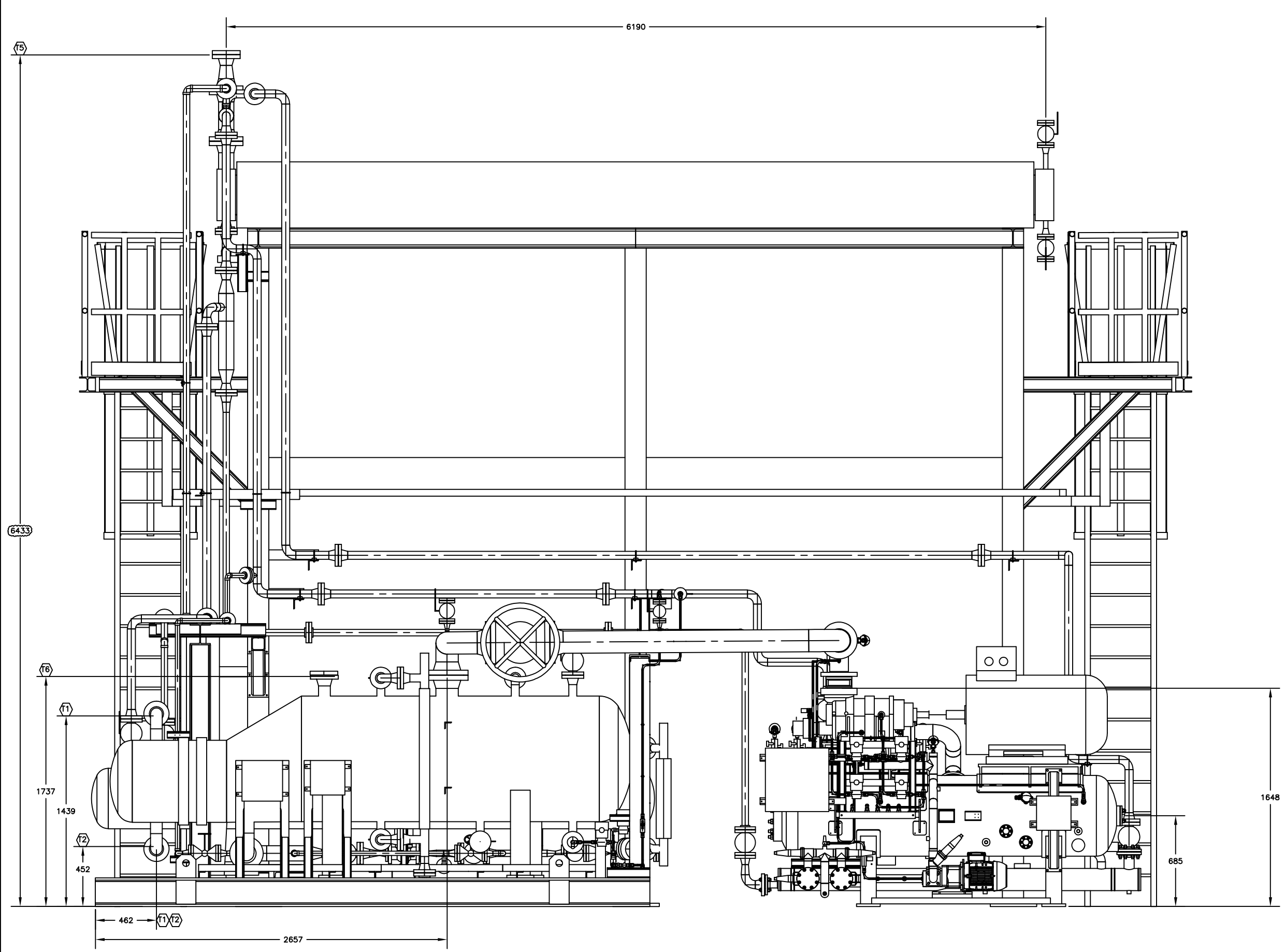

NOTES:
 1. FOR ALL APPLICABLE NOTES, PLEASE REFER TO SHEET 1.

REV.	STATUS	DATE	PURPOSE OF ISSUE	PREP.	CHKD.	APPD.	AUTH.
5	F	31.10.24	FOR APPROVAL	AJD	AJD	IES	SES
4	F	16.09.24	FOR APPROVAL	AJD	AJD	IES	SES
3	F	22.08.24	FOR APPROVAL	AJD	AJD	IES	SES
2	F	22.07.24	FOR APPROVAL	AJD	AJD	IES	SES
1	F	19.07.24	FOR APPROVAL	AJD	AJD	IES	SES
0	F	05.04.24	FOR APPROVAL	AJD	AJD	IES	SES

CLIENT: SERVICE: LOCATION: UNIT TAG NO.:							
VENDOR LOGO							
Contract No.	P.O. No.			SCALE			
DRAWING TITLE: GENERAL ARRANGEMENT DRAWING							
DRAWING NO.				REV.	SHEET No.	SIZE	
				5	3 OF 10	D	

NOTES:
 1. FOR ALL APPLICABLE NOTES, PLEASE REFER TO SHEET 1.

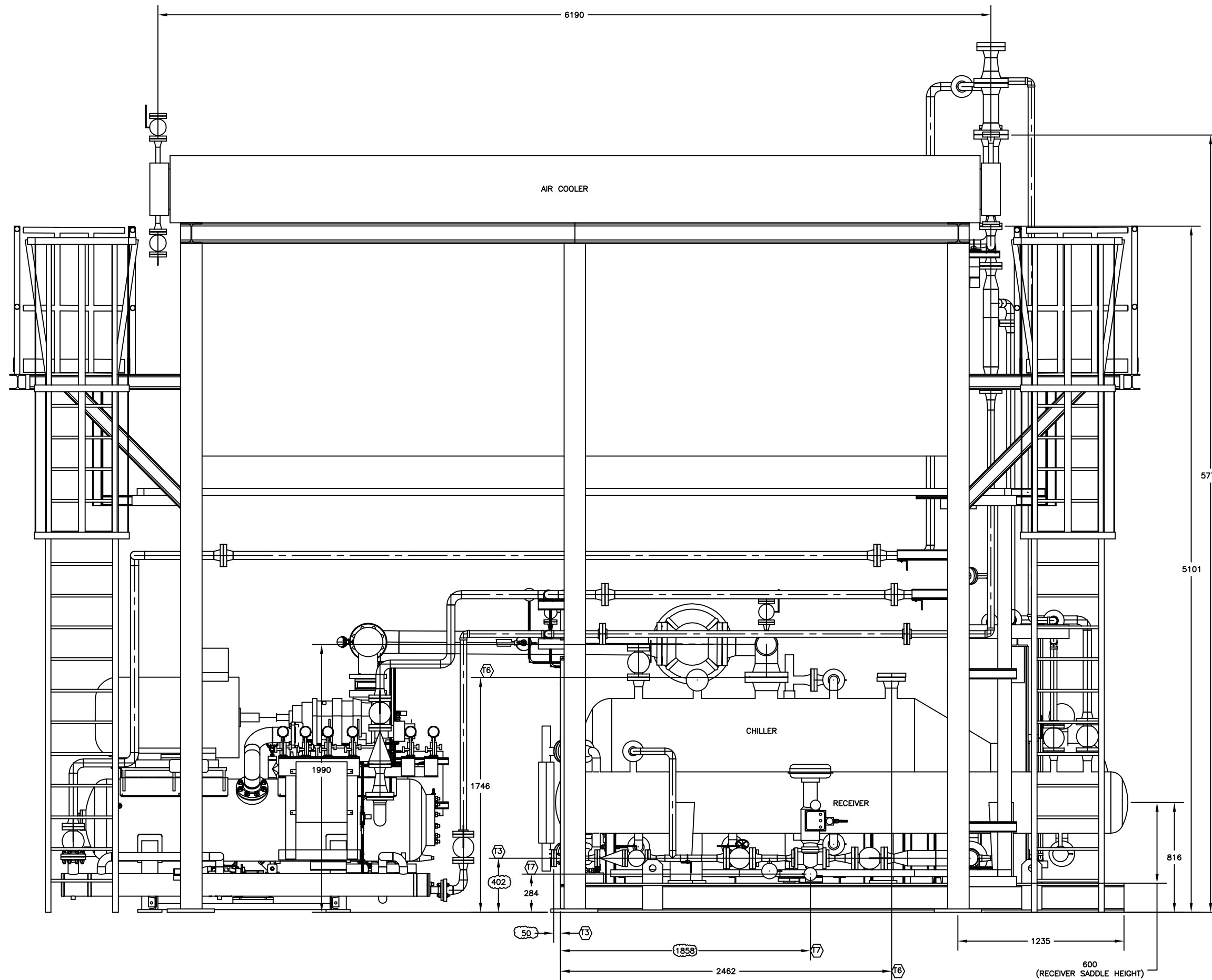

REV.	STATUS	DATE	PURPOSE OF ISSUE	PREP.	CHKD.	APPD.	AUTH.
5	F	31.10.24	FOR APPROVAL	AJD	AJD	IES	SES
4	F	16.09.24	FOR APPROVAL	AJD	AJD	IES	SES
3	F	22.08.24	FOR APPROVAL	AJD	AJD	IES	SES
2	F	22.07.24	FOR APPROVAL	AJD	AJD	IES	SES
1	F	19.07.24	FOR APPROVAL	AJD	AJD	IES	SES
0	F	05.04.24	FOR APPROVAL	AJD	AJD	IES	SES

CLIENT: SERVICE: LOCATION: UNIT TAG NO.:		
VENDOR LOGO		
Contract No.	P.O. No.	SCALE
DRAWING TITLE: GENERAL ARRANGEMENT DRAWING		
DRAWING NO.	REV.	SHEET No. SIZE
	5	4 OF 10 D

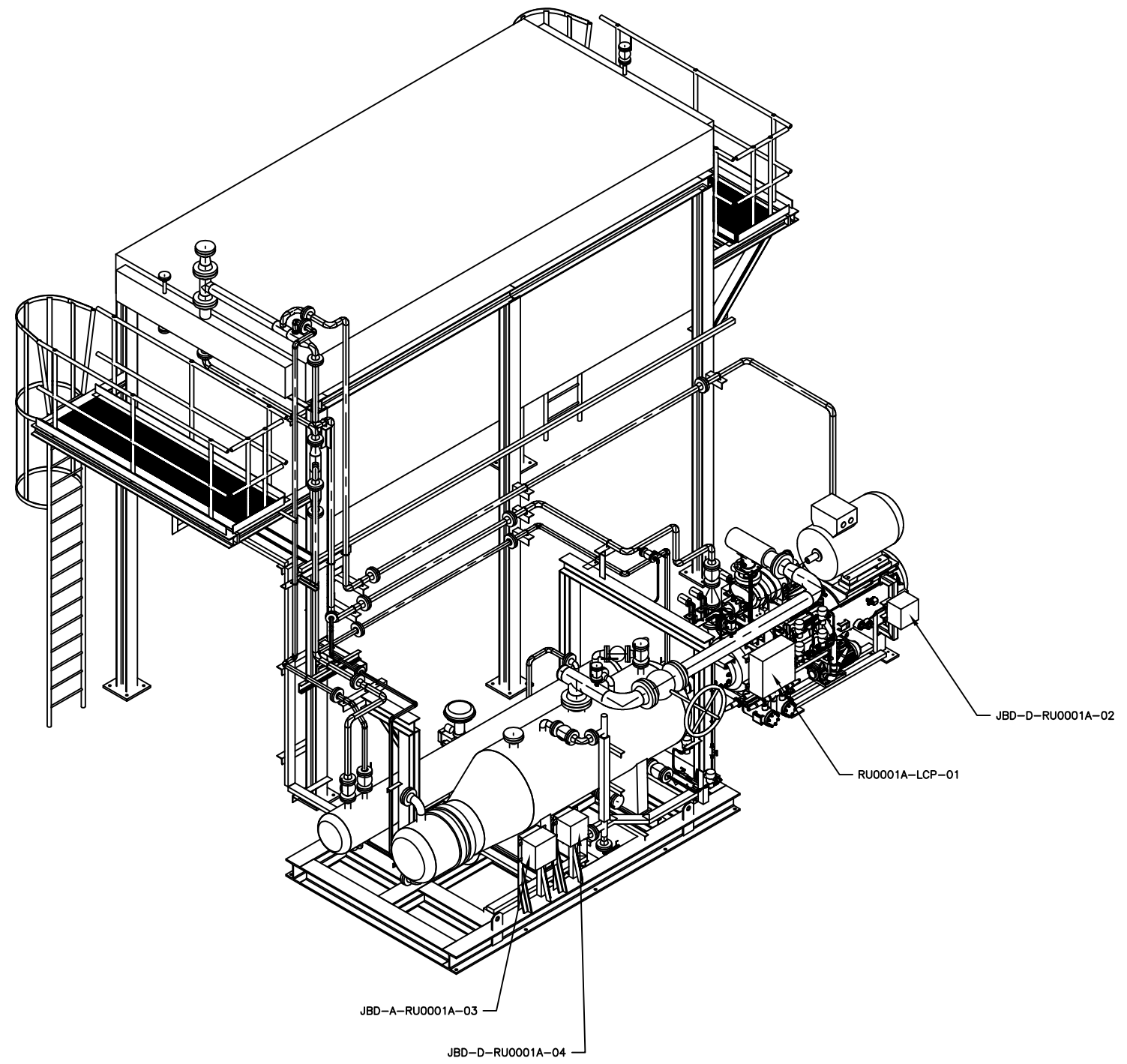

NOTES:
 1. FOR ALL APPLICABLE NOTES, PLEASE REFER TO SHEET 1.

REV.	STATUS	DATE	PURPOSE OF ISSUE	PREP.	CHKD.	APPD.	AUTH.
5	F	31.10.24	FOR APPROVAL	AJD	AJD	IES	SES
4	F	16.09.24	FOR APPROVAL	AJD	AJD	IES	SES
3	F	22.08.24	FOR APPROVAL	AJD	AJD	IES	SES
2	F	22.07.24	FOR APPROVAL	AJD	AJD	IES	SES
1	F	19.07.24	FOR APPROVAL	AJD	AJD	IES	SES
0	F	05.04.24	FOR APPROVAL	AJD	AJD	IES	SES

CLIENT: SERVICE: LOCATION: UNIT TAG NO.:			
VENDOR LOGO			
Contract No.	P.O. No.	SCALE	
DRAWING TITLE:			
DRAWING NO.	REV.	SHEET No.	SIZE
	5	5 OF 10	D

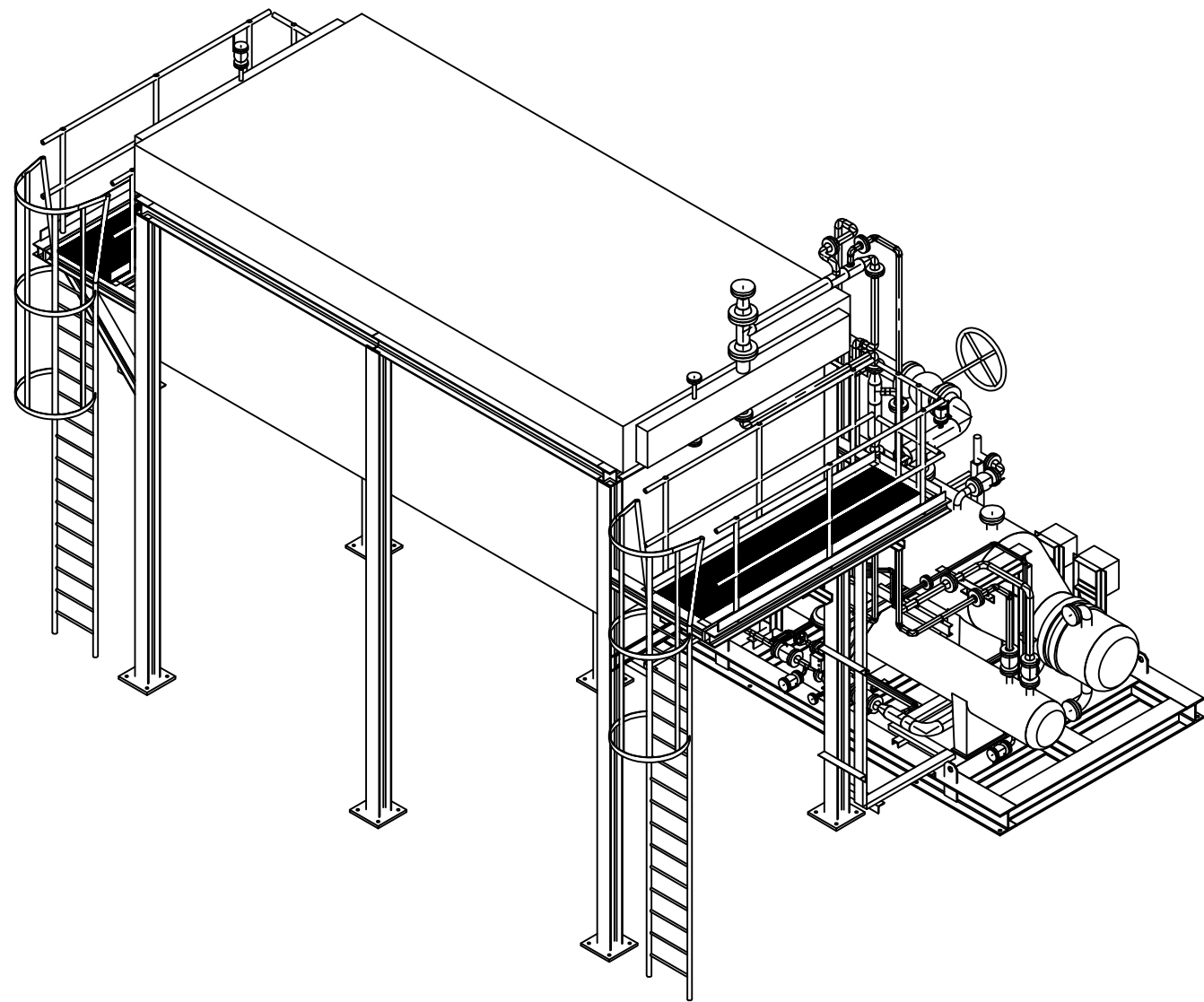

NOTES:

1. FOR ALL APPLICABLE NOTES, PLEASE REFER TO SHEET 1.

5	F	31.10.24	FOR APPROVAL	AJD	AJD	IES	SES
4	F	16.09.24	FOR APPROVAL	AJD	AJD	IES	SES
3	F	22.08.24	FOR APPROVAL	AJD	AJD	IES	SES
2	F	22.07.24	FOR APPROVAL	AJD	AJD	IES	SES
1	F	19.07.24	FOR APPROVAL	AJD	AJD	IES	SES
0	F	05.04.24	FOR APPROVAL	AJD	AJD	IES	SES
REV.	STATUS	DATE	PURPOSE OF ISSUE	PREP.	CHKD.	APPD.	AUTH.

CLIENT: SERVICE: LOCATION: UNIT TAG NO.:							
VENDOR LOGO							
Contract No.	P.O. No.			SCALE			
DRAWING TITLE: GENERAL ARRANGEMENT DRAWING							
DRAWING NO.				REV.	SHEET No.	SIZE	
				5	6 OF 10	D	

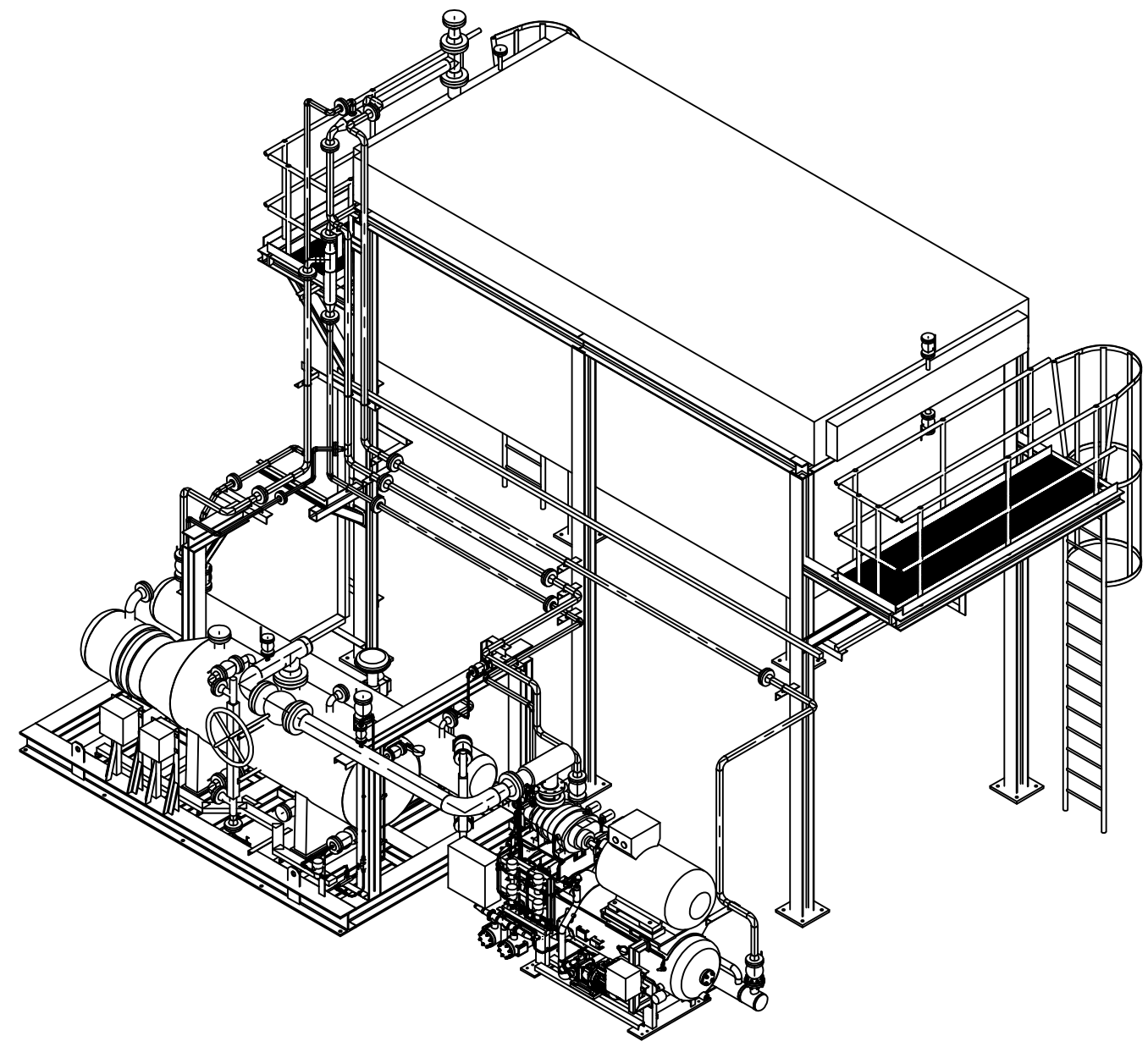

NOTES:

1. FOR ALL APPLICABLE NOTES, PLEASE REFER TO SHEET 1.

5	F	31.10.24	FOR APPROVAL	AJD	AJD	IES	SES
4	F	16.09.24	FOR APPROVAL	AJD	AJD	IES	SES
3	F	22.08.24	FOR APPROVAL	AJD	AJD	IES	SES
2	F	22.07.24	FOR APPROVAL	AJD	AJD	IES	SES
1	F	19.07.24	FOR APPROVAL	AJD	AJD	IES	SES
0	F	05.04.24	FOR APPROVAL	AJD	AJD	IES	SES
REV.	STATUS	DATE	PURPOSE OF ISSUE	PREP.	CHKD.	APPD.	AUTH.
CLIENT: SERVICE: LOCATION: UNIT TAG NO.:							
VENDOR LOGO							
Contract No.		P.O. No.		SCALE			
DRAWING TITLE: GENERAL ARRANGEMENT DRAWING							
DRAWING NO.				REV.	SHEET No.	SIZE	
				5	7 OF 10	D	

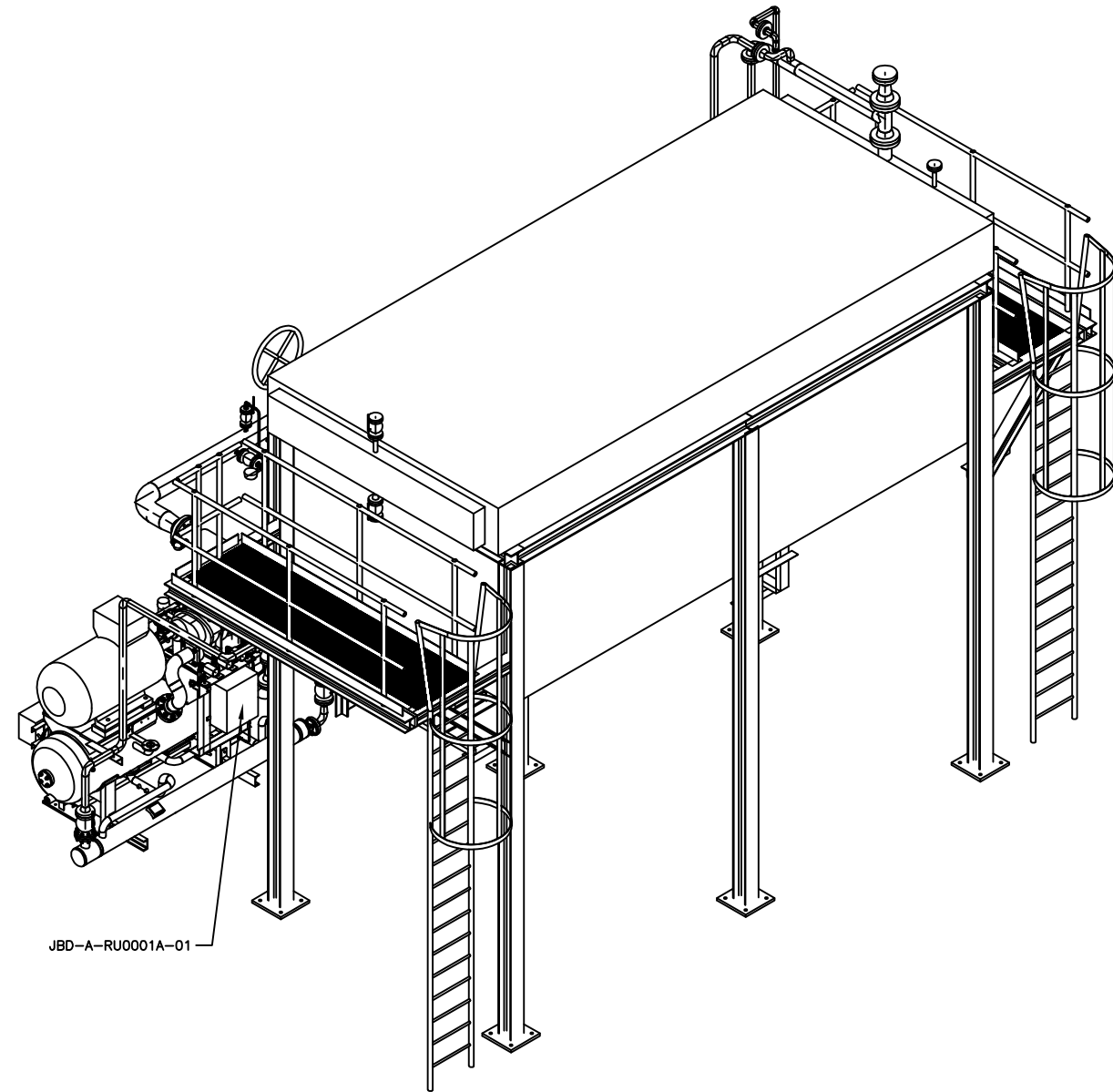

JBD-A-RU0001A-01

NOTES:

1. FOR ALL APPLICABLE NOTES, PLEASE REFER TO SHEET 1.

REV.	STATUS	DATE	PURPOSE OF ISSUE	PREP.	CHKD.	APPD.	AUTH.
5	F	31.10.24	FOR APPROVAL	AJD	AJD	IES	SES
4	F	16.09.24	FOR APPROVAL	AJD	AJD	IES	SES
3	F	22.08.24	FOR APPROVAL	AJD	AJD	IES	SES
2	F	22.07.24	FOR APPROVAL	AJD	AJD	IES	SES
1	F	19.07.24	FOR APPROVAL	AJD	AJD	IES	SES
0	F	05.04.24	FOR APPROVAL	AJD	AJD	IES	SES

CLIENT: SERVICE: LOCATION: UNIT TAG NO.:							
VENDOR LOGO							
Contract No.	P.O. No.			SCALE			
DRAWING TITLE: GENERAL ARRANGEMENT DRAWING							
DRAWING NO.				REV.	SHEET No.	SIZE	
				5	8 OF 10	D	

NOTES:
 1. FOR ALL APPLICABLE NOTES, PLEASE REFER TO SHEET 1.
 2. ANCHOR BOLT & LIFTING LUG LOCATION DETAILS ARE SHOWN IN THIS SHEET.

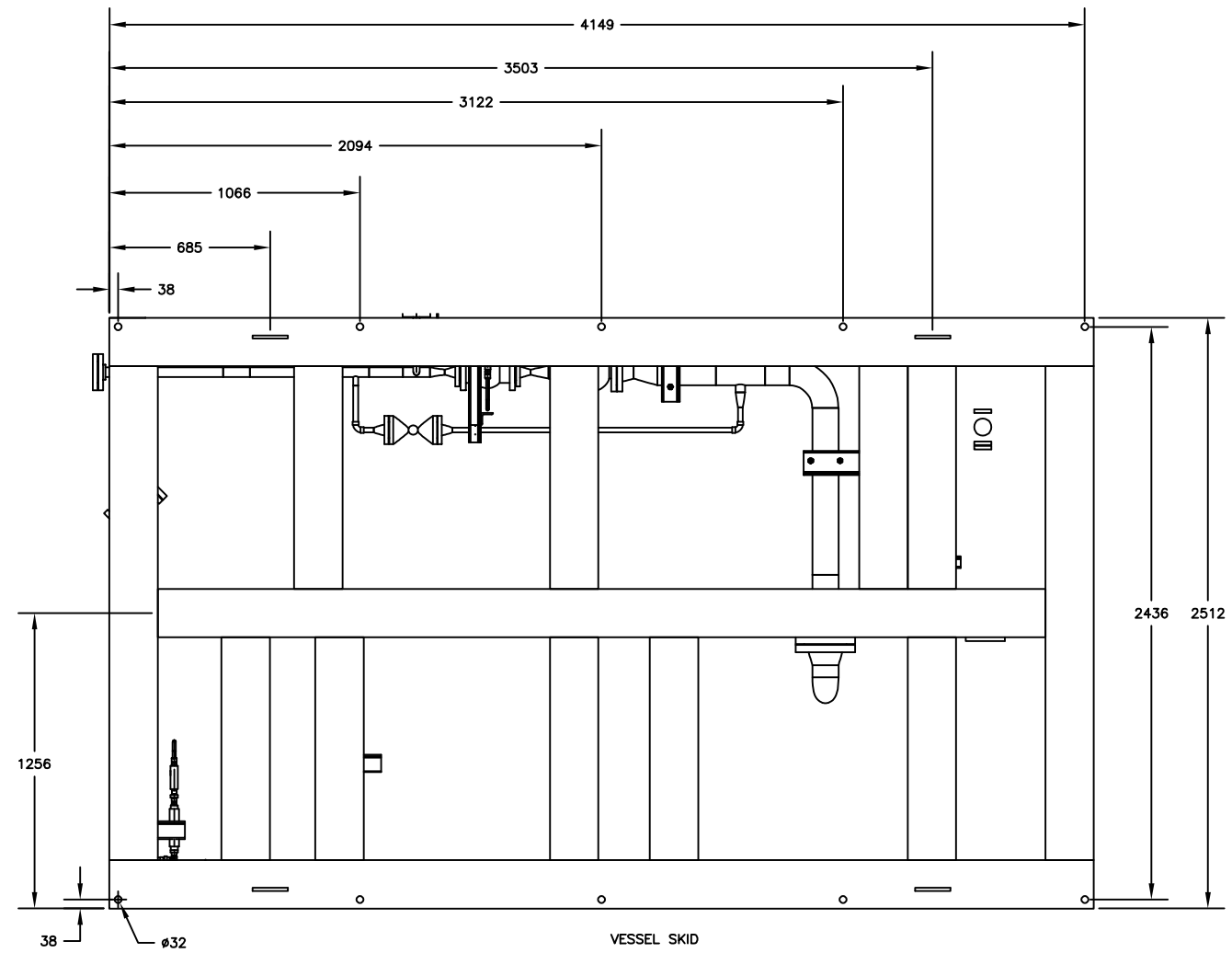
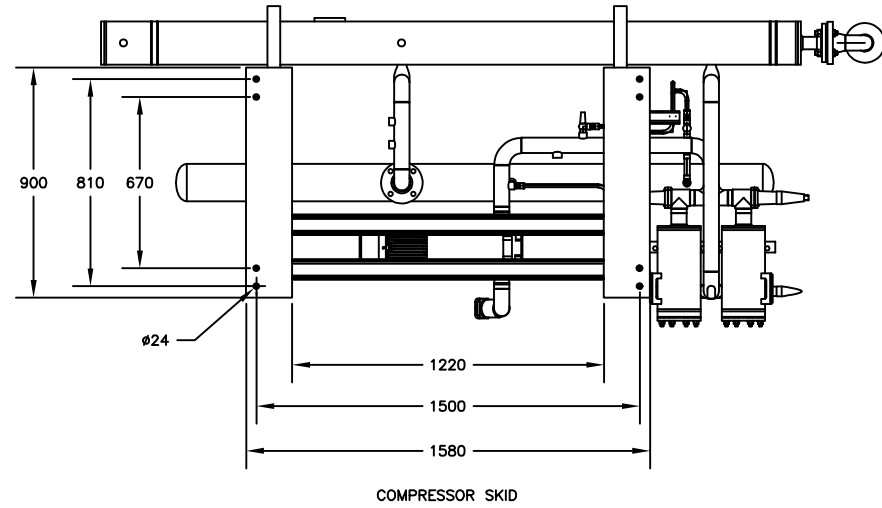

BOTTOM VIEW

REV.	STATUS	DATE	PURPOSE OF ISSUE	PREP.	CHKD.	APPD.	AUTH.
5	F	31.10.24	FOR APPROVAL	AJD	AJD	IES	SES
4	F	16.09.24	FOR APPROVAL	AJD	AJD	IES	SES
3	F	22.08.24	FOR APPROVAL	AJD	AJD	IES	SES
2	F	22.07.24	FOR APPROVAL	AJD	AJD	IES	SES
1	F	19.07.24	FOR APPROVAL	AJD	AJD	IES	SES
0	F	05.04.24	FOR APPROVAL	AJD	AJD	IES	SES

CLIENT: SERVICE: LOCATION: UNIT TAG NO.:		
VENDOR LOGO		
Contract No.	P.O. No.	SCALE
DRAWING TITLE: GENERAL ARRANGEMENT DRAWING		
DRAWING NO.	REV.	SHEET No. SIZE
	5	9 OF 10 D

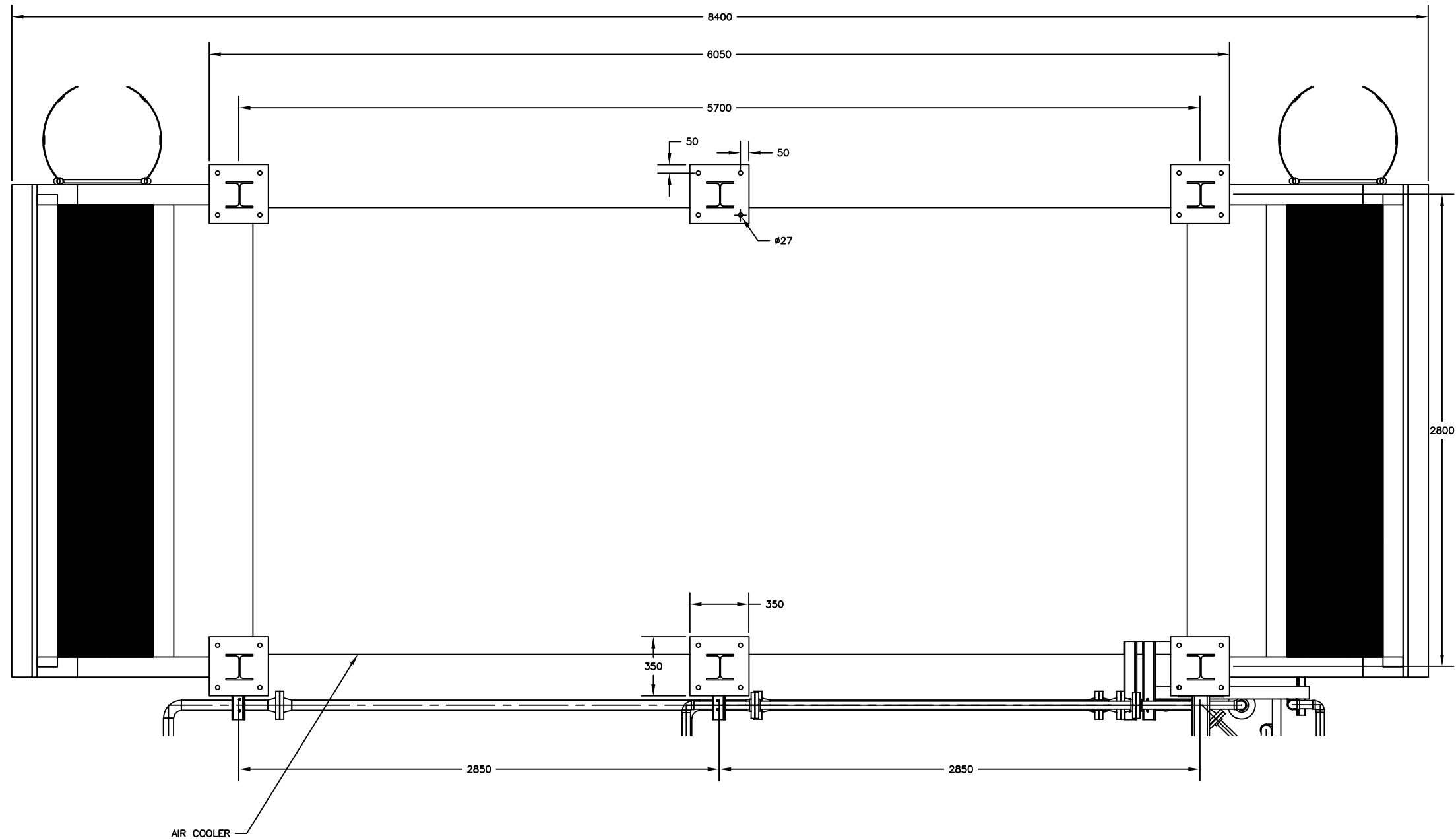

BOTTOM VIEW

NOTES:

1. FOR ALL APPLICABLE NOTES, PLEASE REFER TO SHEET 1.
2. ANCHOR BOLT LOCATION DETAILS ARE SHOWN IN THIS SHEET.

REV.	STATUS	DATE	PURPOSE OF ISSUE	PREP.	CHKD.	APPD.	AUTH.
5	F	31.10.24	FOR APPROVAL	AJD	AJD	IES	SES
4	F	16.09.24	FOR APPROVAL	AJD	AJD	IES	SES
3	F	22.08.24	FOR APPROVAL	AJD	AJD	IES	SES
2	F	22.07.24	FOR APPROVAL	AJD	AJD	IES	SES
1	F	19.07.24	FOR APPROVAL	AJD	AJD	IES	SES
0	F	05.04.24	FOR APPROVAL	AJD	AJD	IES	SES

CLIENT: SERVICE: LOCATION: UNIT TAG NO.:							
VENDOR LOGO							
Contract No.	P.O. No.			SCALE			
DRAWING TITLE: GENERAL ARRANGEMENT DRAWING							
DRAWING NO.				REV.	SHEET No.	SIZE	
				5	10 OF 10	D	