



Toase-eh Park Sanati Gohar Ofogh  
Petrochemical Co.  
**CONCEPTUAL, BASIC and DETAIL DESIGN  
ENGINEERING OF STYRENE PARK OFFSITE**



Document Title: Air Cooler Thermal Data Sheet

Document No.: EI027-DMF-VD-ME-DSH-002

Rev. R1

Page 1 of 4

# STYRENE PARK OFFSITE

**Document Title:**  
**Air Cooler Thermal Data Sheet**

Rev.	Issued Date	DESCRIPTION	PREPARED	CHECKED	APPROVED
R1	1-JUL-2024	IFA	H.Torshizi	H.Torshizi	B.Sheikhbeigi
R0	22-JUN-2024	IFA	H.Torshizi	H.Torshizi	B.Sheikhbeigi



Toase-che Park Sanati Gohar Ofogh  
Petrochemical Co.  
**CONCEPTUAL, BASIC and DETAIL DESIGN  
ENGINEERING OF STYRENE PARK OFFSITE**



Document Title: Air Cooler Thermal Data Sheet

Document No.: EI027-DMF-VD-ME-DSH-002

Rev. R1

Page 2 of 4

**REVISION RECORD SHEET**

Page	Revisions							Page	Revisions						
	R0	R1	R2	R3	R4	R5	R6		R0	R1	R2	R3	R4	R5	R6
1	X	X						41							
2	X	X						42							
3	X	X						43							
4	X							44							
5								45							
6								46							
7								47							
8								48							
9								49							
10								50							
11								51							
12								52							
13								53							
14								54							
15								55							
16								56							
17								57							
18								58							
19								59							
20								60							
21								61							
22								62							
23								63							
24								64							
25								65							
26								66							
27								67							
28								68							
29								69							
30								70							
31								71							
32								72							
33								73							
34								74							
35								75							
36								76							
37								77							
38								78							
39								79							
40								80							

Manufacturer		Heat exchanged (kW)	257.
Model no.		Surface/Item-Finned tube (m2)	1579.2
Customer		Bare tube (m2)	68.101
Plant location		MTD, Eff. (Deg. C)	6.8
Service		Transfer rate-Finned (W/m2-K)	25.561
Type draft	FORCED	Bare tube, service (W/m2-K)	592.73
Bay size (WxL) (m)	2.65 x 6.4	Bare tube, clean (W/m2-K)	679.13
No. of bays/items	1		

### Basic design data

Pressure design code	ASME VIII div 1	Structural code	UBC 97
Tube bundle code stamped	No.	Flammable service	Yes.
Heating coil code stamped	No.	Lethal/toxic service	No.

### Performance Data - Tube Side

Fluid name		Propane		In		Out	
Total fluid entering (kg/hr)	3015.5	Total flow rate (Liq/Vap) (kg/hr)	0.0000 / 3015.5	3015.5 /	0.0000		
Dew/bubble point (Deg. C)	/	Water/Steam (kg/hr)	0.0000 /	0.0000	0.0000 /	0.0000	
Latent heat (kJ/kg)		Noncondensables (kg/hr)		0.0000		0.0000	
Inlet pressure (bar)	19.800	Molecular Wt. (Vap/Non-cond)	/		/		
Pressure drop (All/Calc) (bar)	0.100 / 0.018	Density (Liq/Vap) (kg/m3)	435.84 /	40.275	435.93 /	46.071	
Velocity (Allow/Calc) (m/s)	/	Specific heat (Liq/Vap) (kJ/kg-C)	3.6067 /	2.2738	3.6049 /	2.3920	
Inside fouling resistance (m2-K/W)	0.000170	Thermal cond. (Liq/Vap) (W/m-C)	0.0764 /	0.0253	0.0764 /	0.0238	
Temperature (Deg. C)	In 73.50 / Out 56.32	Viscosity (Liq/Vap) (cP)	0.0730 /	0.0106	0.0730 /	0.0103	

### Performance Data - Air Side

Air inlet temperature (Deg. C)	48.00	Face velocity (m/s)	3.15
Air flow rate/item (m3/s)	45.529	Minimum design ambient temp (Deg. C)	5.00
Mass velocity (kg/s-m2)		Altitude (m)	20.000
Air outlet temperature (Deg. C)	52.28	Static pressure (Pa)	102.95
Air flow rate/fan (m3/s)	26.879		

### Design, Material, and Construction

Design pressure (barG)	22 + F.V	<b>Heating Coil</b>	NO.
Test pressure (barG)		No. of tubes	
Design temperature (Deg. C)	120.00	Tube outside diameter (mm)	
Min. design metal temp. (Deg. C)		Tube material	
<b>Tube bundle</b>		Fin material and type	
Size (WxL) (m)	2.5 X 6.4	Fin thickness (mm)	
No./Bay	1	ASME Code, Sec. VIII, Div. 1	
Number of tube rows	4	Heating fluid	
Bundles in parallel	1	Heating fluid flow rate (kg/hr)	
Bundles in series		Temperature (In/Out) (Deg. C)	/
Structure mounting	Grade	Inlet pressure (bar)	
Pipe rack beams		Pressure drop (All/Calc) (kPa)	/
Ladders, walkways, platforms		Design temperature (Deg. C)	
Structure surface prep.		Design pressure (bar)	
Header surface prep.		Inlet/Outlet nozzle	/
<b>Louver</b>	NO.	<b>Header</b>	
Material		Type	Plug
Action control		Material	SA-516 Gr70(N)
Action type		Corrosion Allowance (mm)	3
		No. of passes	4
		Tube / Tubesheet	Strength weld

## API 661 Air-Cooled Heat Exchanger - Specification Sheet

Job No. _____	Page _____ Page 2 of 2	Item No. _____ Air Cooler
Page _____	Page 2 of 2	By _____
Date _____	June 30, 2024	Revision _____
Proposal No. _____	02612N	R1
Inquiry No. _____	_____	Contract No. _____
_____	_____	Order No. _____

### Design, Material, and Construction (continued)

<b>Header (continued)</b>				No./Bundle	140
Slope / Split	1% on last pass / No			Length	(m) 6.096
Plug material	SA 350 LF2 CL.1			Pitch	(mm) 69.850
Gasket material	Soft Iron			Layout	Triangular
<b>Nozzle</b>	No.	Size, (in)	Rating/Facing	<b>Fin</b>	
Inlet	1	4	#300	Type	Extruded
Outlet	1	2	#300	Material	Aluminum
Vent				Thickness (Base / Tip)	(mm) 1 / 0.24
Drain				Selection temp.	(C) _____
Chemical Cleaning				Outside diameter	(mm) 57.150
Min. Wall Thk.				Fin density	(fin/meter) 433.1
<b>Tube</b>				ASME Code, Sec. VIII, Div. 1	_____
Material			SA-334 6	Customer Specifications	_____
Tube outside diameter	(mm)		25.400		
Min wall thickness	(mm)		1.651		

### Mechanical Equipment

<b>Fan</b>				RPM	1500
Manufacturer	Axial Fans Int Srl (or equivalent)			Service factor	_____
No./Bay			2	Enclosure	Exec / IP55
RPM	(Revs/min.)			Voltage	400
Diameter	(ft)		7	Phase	3
No. of blades				Cycle	50
Angle	(degrees)			Fan noise level	(dB) max 85
Pitch adjustment			100% Manual	<b>Speed Reducer</b>	
Blade material			Aluminium	Type	V- belt
Hub material			Manufacturer Standard	Manufacturer	_____
@design temp	(kW)			No./Bay	2
@min. ambient temp				Service factor	_____
Tip speed				Speed ratio	_____
<b>Driver</b>				Support	_____
Type			Electrical	Vib. switch	YES
Manufacturer			OME ELECTRIC OR AVL	Enclosure	_____
No./Bay					
Driver (1)	(kW)		7.5		

### Controls - Air Side

Air recirculation	_____	Louvers	_____
Degree control of outlet process temp. (Max. Cooling), +/-	_____ / _____	Positioner	_____
Action on control signal failure	_____	Signal air pressure (bar)	_____
Fan pitch	_____	From	_____ To _____
Louvers	_____	From	_____ To _____
Actuator air supply	_____	Supply air pressure (bar)	_____
Fan	_____	From	_____ To _____
		From	_____ To _____

### Shipping

Plot area (WxL)	(m) 2.65 x 6.4	Total weight, Dry / Wet (Kg)	( Based On HTRI) 11,800 / 12,300
Bundle weight	(kg) _____	Shipping	(kg) _____
Bay	(kg) _____		

**1) STD. nominated power.**

# STYRENE PARK OFFSITE



---

## Document Title: Axial Fan Data Sheet

R2	18-08-2024	IFA	F.Aghaienezhad	J.Beigloo	A.Gholizadeh
R1	06-08-2024	IFA	F.Aghaienezhad	J.Beigloo	A.Gholizadeh
R0	22-06-2024	IFA	F.Aghaienezhad	J.Beigloo	A.Gholizadeh
<b>Rev.</b>	<b>Issued Date</b>	<b>DESCRIPTION</b>	<b>PREPARED</b>	<b>CHECKED</b>	<b>APPROVED</b>

### REVISION RECORD SHEET

Page Page	Revisions							Page	Revisions						
	R0	R1	R2	R3	R4	R5	R6		R0	R1	R2	R3	R4	R5	R6
1	X	X	X					41							
2	X	X	X					42							
3	X	X						43							
4	X	X	X					44							
5	X	X						45							
6	X	X	X					46							
7	X	X						47							
8	X	X						48							
9	X	X						49							
10	X	X						50							
11								51							
12								52							
13								53							
14								54							
15								55							
16								56							
17								57							
18								58							
19								59							
20								60							
21								61							
22								62							
23								63							
24								64							
25								65							
26								66							
27								67							
28								68							
29								69							
30								70							
31								71							
32								72							
33								73							
34								74							
35								75							
36								76							
37								77							
38								78							
39								79							
40								80							

	<p style="text-align: center;">Toase-eh Park Sanati Gohar Ofogh Petrochemical Co. <b>CONCEPTUAL, BASIC and DETAIL DESIGN ENGINEERING OF STYRENE PARK OFFSITE</b></p>		 	
	<p style="text-align: center;">Document Title: Axial Fan Data Sheet</p>			
	<p>Document No.: EI027-DMF-VD-ME-DSH-016- R2</p>		<p>Rev. R2</p>	<p>Page 3 of 10</p>

<b>AXIAL FAN DATA SHEET (PROJECT 1158) Qty = 4</b>			
<b>BASIC DATA</b>			
1	Item No.		Air Cooler
2	Quantity	Manual Adjustable Pitch	100%
		Automatic Adjustable Pitch	-
3	Positioner		NO
4	BEARING BLOCK		YES
5	Blade Material	Aluminum (ASTM,B-179)	YES
		Fiber glass	NO
6	Type of Air cooler/ Inlet		FORCED / CONICAL L/D=0.05
7	Fan Diameter		7/ 2134 (ft /mm)
8	Fan Ring Diameter		2156 (mm)
9	Fan Ring Height		600 (mm)
10	Altitude		20 (m)
11	Relative Humidity		65 (%)
12	Temperature inlet /outlet		48 /52.28 ( ° C)
13	Actual flow		26.879 (m3/s)
14	Actual static pressure		102.95 (Pa)
15	Fan RPM		382 (rpm)
16	Tip speed		42.7 (m/s)
17	Motor power rating		7.5 (KW)
18	Noise level (at one meter)		85 (db)
19	Min Temperature		5 ° C



Via A. Gramsci, 62 - 28050 Pombia (NO) Italy - Phone +39-0321-968311 - Fax +39-0321-958992  
 9660 Grunwald Road - Beasley Texas 77417 - Phone +1 -281-275 8390 - Fax +1 -281-275 8388

Kai Xuan Hua Yuan, 111 Zhong Cao Road, Shanghai 200030, P.R.China - Phone +86-2164-686460 - Fax +86-2164-686460

Customer Name	Job Reference
Job Name	
Item Number	Date <b>8/6/2024</b>

### CHARACTERISTICS

Required Volume	<b>26.87</b> m <sup>3</sup> /sec	Required Static Pressure	<b>102.95</b> Pa
Pressure recovery	<b>0.00</b> Pa	Fan static pressure	<b>102.95</b> Pa
Velocity pressure	<b>28.98</b> Pa	Total pressure	<b>131.93</b> Pa
Air Temperature	<b>48.0</b> °C	Site Elevation	<b>20.0</b> m
Inlet Air Humidity (%)	<b>65.0</b>	Inlet Air Density	<b>1.068</b> kg/m <sup>3</sup>
Fan diameter	<b>2134</b> mm	Fan ring diameter	<b>2156</b> mm
Blade Airfoil	<b>24L</b> ALU	Rotor hub type	<b>B3</b>
Speed	<b>382.0</b> RPM	Blade Tip Speed	<b>42.68</b> m/sec
N° blades	<b>4</b>	Blade Operating Freq. +/-5%	<b>722</b> cpm
Static efficiency	<b>61.4</b> %	Total efficiency	<b>78.7</b> %
Blade pitch angle	<b>8.5</b> (°)	Rotor shaft power	<b>4.5</b> kW
Min. Ambient Temperature	<b>5.0</b> °C	Rotor shaft power @ 5.0 °C	<b>5.3</b> kW
		Rotor shaft power @ API point	<b>6.0</b> kW
Pressure Margin (%)	<b>65</b> <sup>1</sup> / <b>95</b> <sup>2</sup>	Volume Margin (%)	<b>28</b> <sup>1</sup>
Tip Clearance/D	<b>0.005</b>	Inlet	<b>Conical L/D=0.05</b>
Diffuser angle (°)		Diffuser:Length/D	
Inlet Obstacle a/A		Inlet Obstacle x/D	
Outlet Obstacle a/A		Outlet Obstacle x/D	
Installation Type	<b>Forced</b>	Aerod axial force	<b>472</b> N
Rotor total weight	<b>52</b> kg		
Rotor inertia PD <sup>2</sup>	<b>35</b> kg x m <sup>2</sup>		
Max residual unbalance	<b>13.1</b> N		
Blade Failure Load	<b>3847</b> N		
2 Blades Failure Load	<b>5441</b> N		
Xs Static deflection	<b>55</b> mm	Xr Running deflection	<b>43</b> mm

<sup>1</sup> according to API <sup>2</sup> at Design Pitch Angle

### NOISE CHARACTERISTICS

Tolerance on sound values +/- 2 dB(A)

PWL (± 2)	SPL @	Inlet / outlet (± 2)	Side (± 2)
<b>86</b> dB(A)	<b>1.0</b> m From Fan	<b>78</b> dB(A)	<b>65.8</b> dB(A)

Octave [Hz]	31.5	63	125	250	500	1000	2000	4000	8000
-------------	------	----	-----	-----	-----	------	------	------	------

**ROTOR MODEL 2134- 4-24L/B3T**

**PAC**

All data must be approved by Cofimco

Fantastic.NET 2008.2.2





Via A. Gramsci, 62 - 28050 Pombia (NO) Italy - Phone +39-0321-968311 - Fax +39-0321-958992  
9660 Grunwald Road - Beasley Texas 77417 - Phone +1 -281-275 8390 - Fax +1 -281-275 8388

Kai Xuan Hua Yuan, 111 Zhong Cao Road, Shanghai 200030, P.R.China - Phone +86-2164-686460 - Fax +86-2164-686460

Customer Name

Job Reference

Job Name

Item Number

Date **8/6/2024**

### STATIC PRESSURE vs VOLUME CURVE

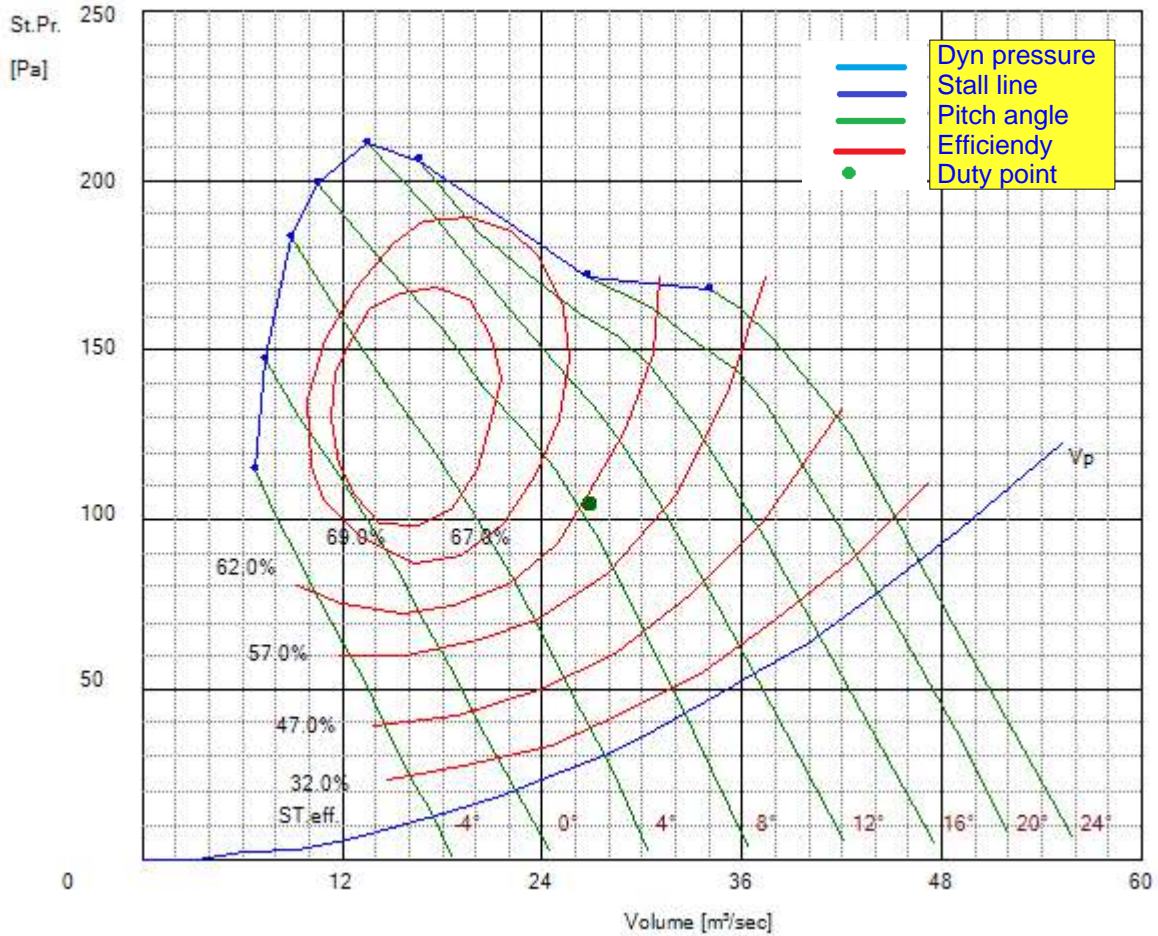

Inlet Air Density 1.068 kg/m<sup>3</sup>  
382 RPM = 42.68 m/sec  
Pressure recovery 0.00 Pa  
Rotor shaft power 4.5 kW  
PWL (± 2) 86 dB(A)

**ROTOR MODEL 2134- 4-24L/B3T**

**PAC**

All data must be approved by Cofimco

Fantastic.NET 2008.2.2



Via A. Gramsci, 62 - 28050 Pombia (NO) Italy - Phone +39-0321-968311 - Fax +39-0321-958992  
9660 Grunwald Road - Beasley Texas 77417 - Phone +1 -281-275 8390 - Fax +1 -281-275 8388

Kai Xuan Hua Yuan, 111 Zhong Cao Road, Shanghai 200030, P.R.China - Phone +86-2164-686460 - Fax +86-2164-686460

Customer Name

Job Reference

Job Name

Item Number

Date **8/6/2024**

### FAN POWER vs VOLUME CURVE

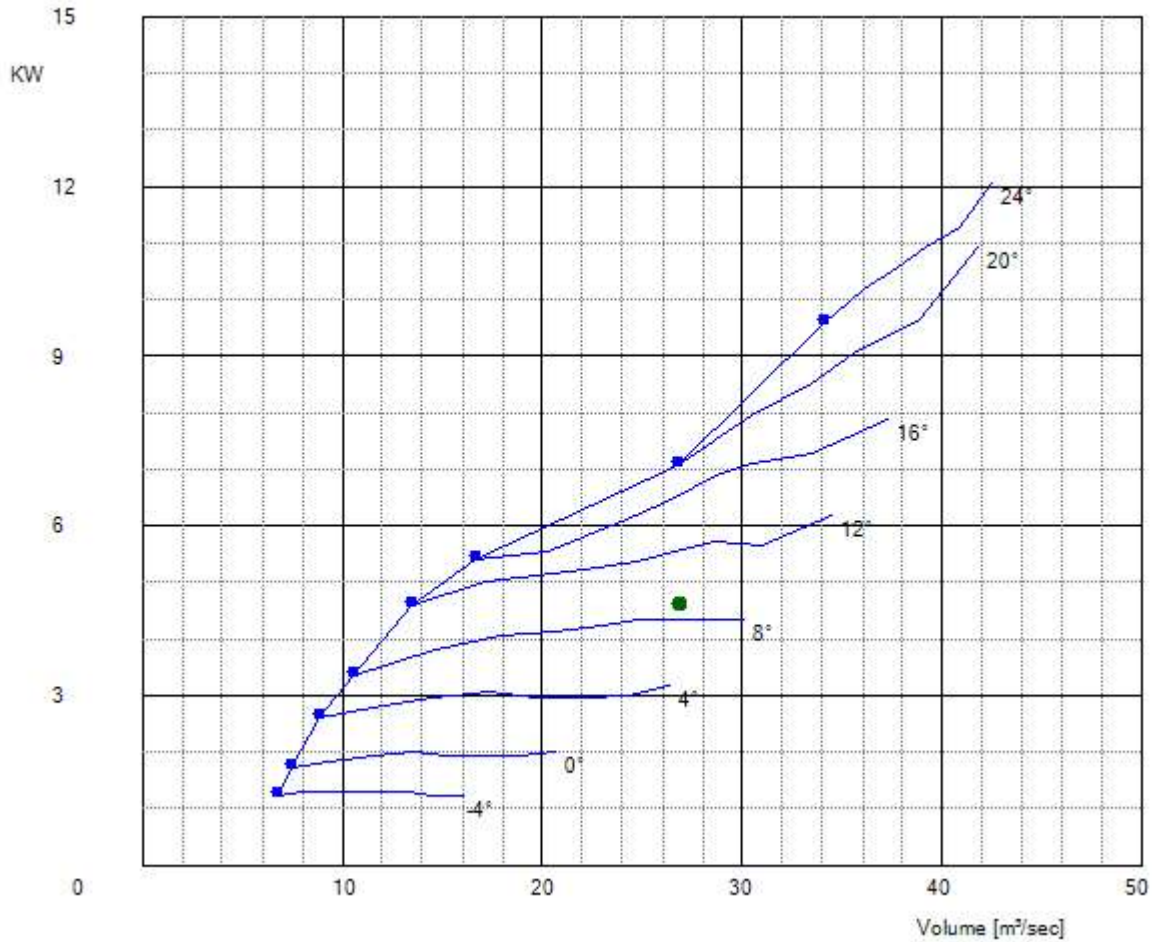

Inlet Air Density 1.068 kg/m<sup>3</sup>  
382 RPM = 42.68 m/sec  
Pressure recovery 0.00 Pa  
Rotor shaft power 4.5 kW

**ROTOR MODEL 2134- 4-24L/B3T**

**PAC**

All data must be approved by Cofimco

Fantastic.NET 2008.2.2



Via A. Gramsci, 62 - 28050 Pombia (NO) Italy - Phone +39-0321-968311 - Fax +39-0321-958992  
9660 Grunwald Road - Beasley Texas 77417 - Phone +1 -281-275 8390 - Fax +1 -281-275 8388

Kai Xuan Hua Yuan, 111 Zhong Cao Road, Shanghai 200030, P.R.China - Phone +86-2164-686460 - Fax +86-2164-686460

Customer Name

Job Reference

Job Name

Item Number

Date **8/6/2024**

### TORQUE CURVE

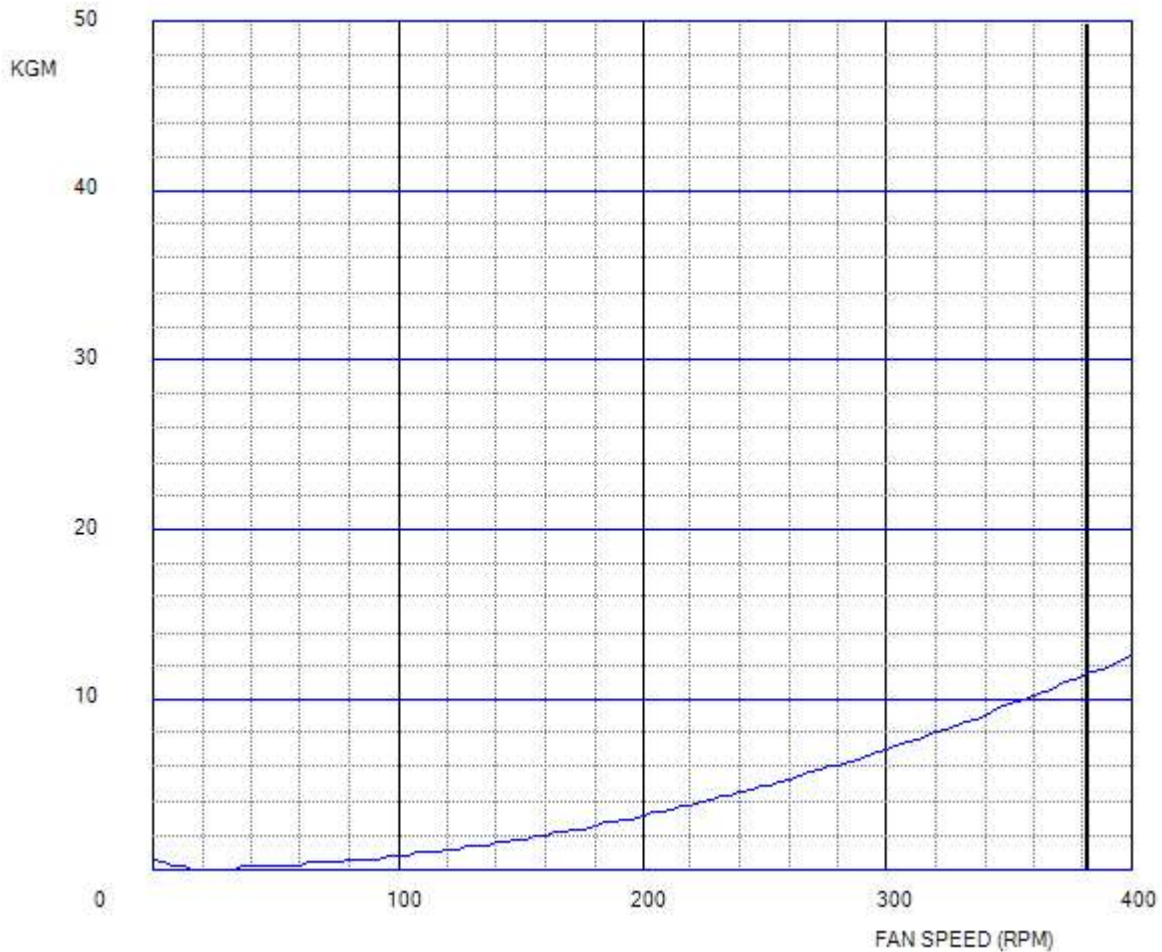

Rotor shaft power 4.5 kW  
RPM = 382.0  
Torque @ 382.0 rpm = 11.5 kgm

**ROTOR MODEL 2134- 4-24L/B3T**

**PAC**

All data must be approved by Cofimco

Fantastic.NET 2008.2.2



Via A. Gramsci, 62 - 28050 Pombia (NO) Italy - Phone +39-0321-968311 - Fax +39-0321-958992  
9660 Grunwald Road - Beasley Texas 77417 - Phone +1 -281-275 8390 - Fax +1 -281-275 8388

Kai Xuan Hua Yuan, 111 Zhong Cao Road, Shanghai 200030, P.R.China - Phone +86-2164-686460 - Fax +86-2164-686460

Customer Name

Job Reference

Job Name

Item Number

Date **8/6/2024**

### CAMPBELL DIAGRAM

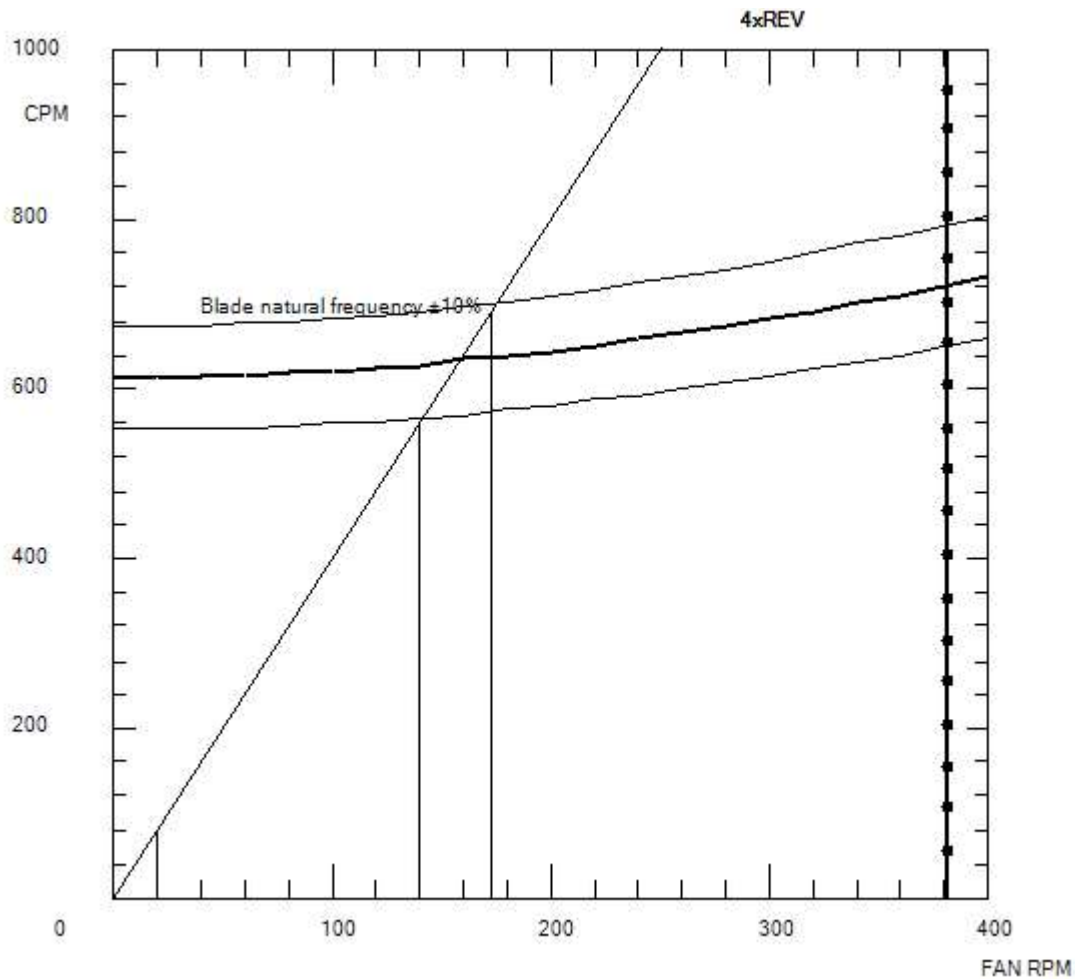

N° blades 4

382 RPM = 42.68 m/sec

**ROTOR MODEL 2134- 4-24L/B3T**

**PAC**

All data must be approved by Cofimco

Fantastic.NET 2008.2.2



Via A. Gramsci, 62 - 28050 Pombia (NO) Italy - Phone +39-0321-968311 - Fax +39-0321-958992  
 9660 Grunwald Road - Beasley Texas 77417 - Phone +1 -281-275 8390 - Fax +1 -281-275 8388

Kai Xuan Hua Yuan, 111 Zhong Cao Road, Shanghai 200030, P.R.China - Phone +86-2164-686460 - Fax +86-2164-686460

Customer Name

Job Reference

Job Name

Item Number

Date **8/6/2024**

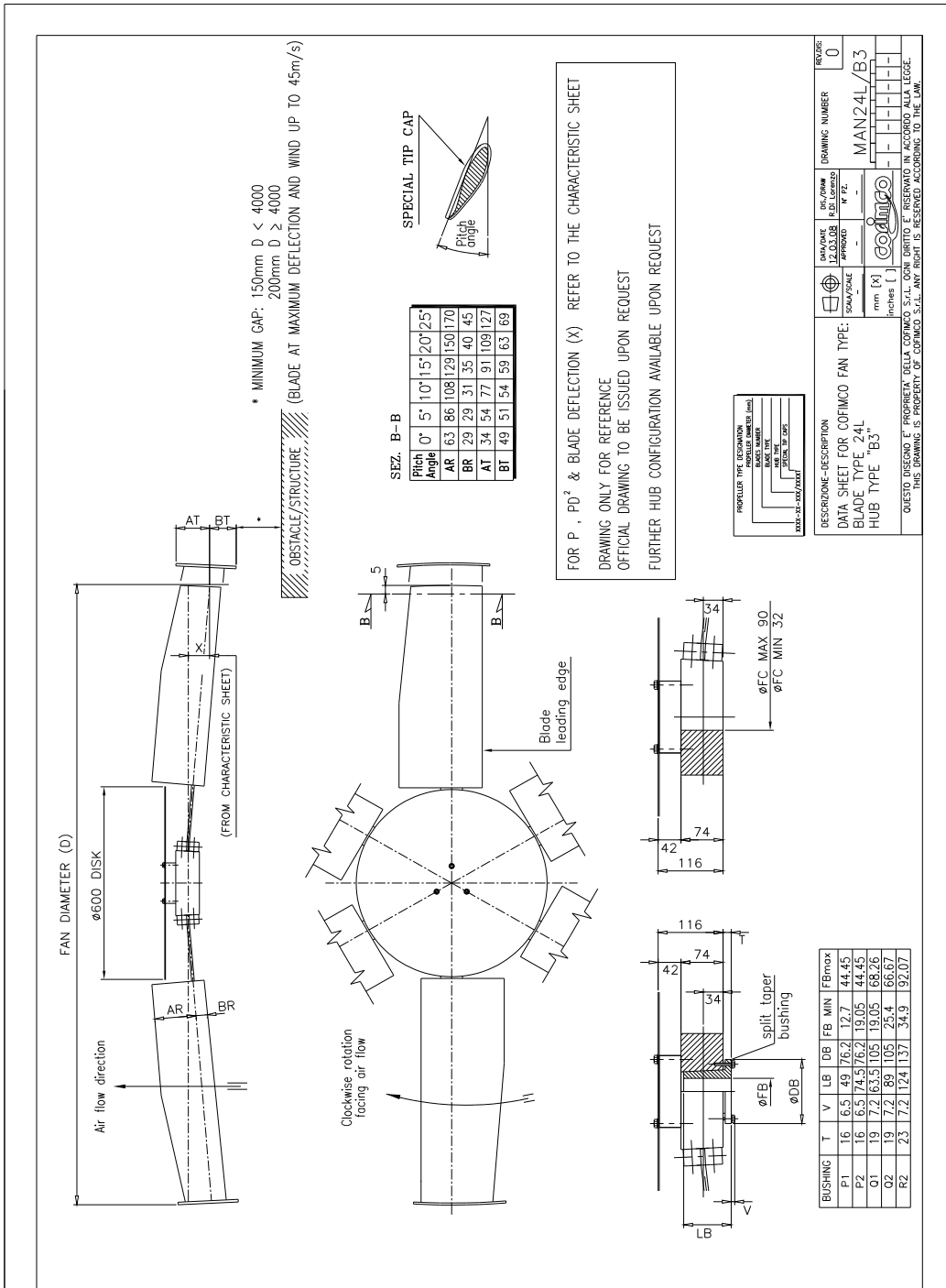

**ROTOR MODEL 2134- 4-24L/B3T**

**PAC**

All data must be approved by Cofimco

Fantastic.NET 2008.2.2



Toase-eh Park Sanati Gohar Ofogh  
Petrochemical Co.  
**CONCEPTUAL, BASIC and DETAIL DESIGN  
ENGINEERING OF STYRENE PARK OFFSITE**



**dt** Damafin  
thermal technology

Document Title: Electrical Motor Data Sheet

Document No.: EI027-DMF-VD-EL-DSH-017-R4

Rev. R4

Page 1 of 3

# STYRENE PARK OFFSITE

## Document Title: Electrical Motor Data Sheet

R4	24-11-2024	IFA	F.Aghaienezhad	J.Beigloo	A.Gholizadeh
R3	06-11-2024	IFA	F.Aghaienezhad	J.Beigloo	A.Gholizadeh
R2	06-10-2024	IFA	F.Aghaienezhad	J.Beigloo	A.Gholizadeh
R1	11-08-2024	IFA	F.Aghaienezhad	J.Beigloo	A.Gholizadeh
R0	22-06-2024	IFA	F.Aghaienezhad	J.Beigloo	A.Gholizadeh
<b>Rev.</b>	<b>Issued Date</b>	<b>DESCRIPTION</b>	<b>PREPARED</b>	<b>CHECKED</b>	<b>APPROVED</b>



Toase-che Park Sanati Gohar Ofogh  
Petrochemical Co.  
**CONCEPTUAL, BASIC and DETAIL DESIGN  
ENGINEERING OF STYRENE PARK OFFSITE**



Document Title: Electrical Motor Data Sheet





Document No.: EI027-DMF-VD-EL-DSH-017-R4

Rev. R4

Page 2 of 3

**REVISION RECORD SHEET**

Page Page	Revisions							Page	Revisions						
	R0	R1	R2	R3	R4	R5	R6		R0	R1	R2	R3	R4	R5	R6
1	X	X	X	X	X			41							
2	X	X	X	X	X			42							
3	X	X	X	X	X			43							
4		X	X					44							
5		X	X					45							
6		X	X					46							
7		X	X					47							
8		X	X					48							
9		X	X					49							
10		X	X					50							
11		X						51							
12		X						52							
13		X						53							
14		X						54							
15								55							
16								56							
17								57							
18								58							
19								59							
20								60							
21								61							
22								62							
23								63							
24								64							
25								65							
26								66							
27								67							
28								68							
29								69							
30								70							
31								71							
32								72							
33								73							
34								74							
35								75							
36								76							
37								77							
38								78							
39								79							
40								80							

 	<b>Toase-eh Park Sanati Gohar Ofogh Petrochemical Co.</b> <b>CONCEPTUAL, BASIC and DETAIL DESIGN ENGINEERING OF STYRENE PARK OFFSITE</b>	 
	Document Title: Electrical Motor Data Sheet	
	Document No.: EI027-DMF-VD-EL-DSH-017-R4	Rev. R4      Page 3 of 3

MOTOR BASIC DATA (1158)		
INSTALLATION SITE		
QUANTITY/ Tag number	4/ RU0001A-M-02, RU0001A-M-03, RU0001B-M-02, <b>RU0001B-M-03</b>	
BRAND-MODEL	Marathon- E3ABL	
RATED POWER	7.5 kw	
SUPPLY VOLTS	400±5%	
FREQUENCY	50±2%	
NUMBER OF POLE	4	
WINDING CONNECTIONS/ROTATION	Delta	
COUPLING TYPE	V-Belt(Belt & Pulley)	
NOMIAL SPEED	1500 rpm	
DUTY CATEGORY	S1	
INVERTER DUTY	YES	
ALTITUDE	20 m	
AMBIENT TEMPRATURE MIN/MAX	5/48 C	
RELATIVE HUMIDITY (RH)	65%	
STARTING METHOD	2-DOL /2-VFD	
CABLE GLAND SUPPLIED	YES	
DIRECTION OR ROTATION	Both	
ISULATION CLASS/TEMP. RISE	F/B	
COOLING	(IC 411)	
AREA CLASSIFICATION	Ex db IIB T4	
WINDING TEMPERATURE . DETECTORS (PTC RELAY)	N.A	
ANTI-CONDANATION HEATER (SPACE HEATER)	N.A	
MOUNTING (TYPE OF INSTALATION)	IMV3	
PROTECTION DEGREE FOR MOTOR/FOR TERMINAL BOX	IP55//IP55	
ROTOR CAGE MATERIAL (AL)	CAST IRON	
PAINT SYSTEM	STANDARD COLOR-RAL (5015)	
CABLE TYPE AND SIZE (FEEDER CABLE BY CLIENT)	MAIN	18~21 mm
	HEATER	N.A
	PTC	N.A
THERED (GLAND) ENTRY	MAIN	2XM32
	HEATER	N.A
	PTC	N.A
EARTH TERMINALS	IN & EXT	
MAX NOISE LEVEL (AT ONE METER)	< 85	
LIFTING DEVICE	YES	
DRAIN PLUGS	NO	
NO OF PHASE	3	
IE (EFFICIENCY CLASS)	IE=3	
PF (COS &)	0.84	
TYPE TEST	NO	
MOTOR SUITABLE FOR VCDS (Y/N)	NO	
CURVE & OUTLINE & COMPLETE CATALOUGE (Y/N)	YES	

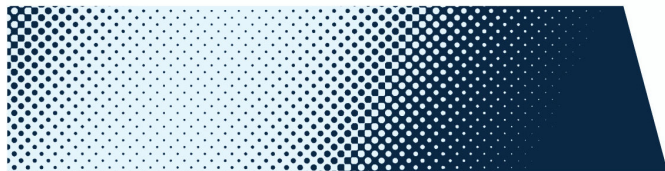

<b>Accreditation (National)</b>	IEC 60079									
<b>Hazardous Classification</b>	Ex db IIB T4									
<b>Series Model Type</b>	E3ABL									
<b>Frame Size</b>	132M									
<b>Rated Output Power</b>	7.5 kW									
<b>Rated Speed</b>	1465 r/min									
<b>Number of Poles</b>	4 Pole									
<b>Number of Phases</b>	3 Phase									
<b>Voltage</b>	400 V									
<b>Frequency</b>	50 Hz									
<b>Duty Cycle</b>	S1									
<b>Service Factor</b>	1.00									
<b>Operating Altitude</b>	1000 masl									
<b>Insulation Class</b>	F (155°C)									
<b>Temperature Rise</b>	80K (B class)									
<b>Ambient Temperature</b>	-15°C ~ 50°C									
<b>Method of Cooling</b>	IC411 (TEFC - Totally Enclosed Fan Cooled)									
<b>Degree of Protection (Ingress Level)</b>	IP55									
<b>Material of Construction</b>	Cast Iron									
<b>Connection</b>	Δ/Y									
<b>Full Load Current [ I<sub>N</sub> ]</b>	14.43									
<b>Locked Rotor Current [ I<sub>L</sub> / I<sub>N</sub> ]</b>	7.50									
<b>Full Load Torque [ T<sub>N</sub> ]</b>	48.89 Nm									
<b>Locked Rotor Torque [ T<sub>L</sub> / T<sub>N</sub> ]</b>	2.0									
<b>Breakdown Torque [ T<sub>B</sub> / T<sub>N</sub> ]</b>	2.3									
<b>Efficiency Class</b>	IE3									
<b>Load</b>										
<b>Efficiency</b>	<table border="1"><thead><tr><th>100% load</th><th>75% load</th><th>50% load</th></tr></thead><tbody><tr><td>90.4%</td><td>90.3%</td><td>89.7%</td></tr><tr><td>0.84</td><td>0.79</td><td>0.69</td></tr></tbody></table>	100% load	75% load	50% load	90.4%	90.3%	89.7%	0.84	0.79	0.69
100% load	75% load	50% load								
90.4%	90.3%	89.7%								
0.84	0.79	0.69								
<b>Power Factor (cos φ)</b>										
<b>Bearing Configuration (DE / NDE)</b>	Ball Bearing / Ball Bearing									
<b>Bearing Series Type</b>	<b>DE:</b> 6208-2Z/C3 <b>NDE:</b> 6208-2Z/C3									
<b>Bearing Lubrication Type</b>	Grease - ESSO UNIREX N2									
<b>Vibration</b>	1.6 mm/sec									
<b>Moment of inertia (kg.m<sup>2</sup>)</b>	0.0488									
<b>Direction of Rotation</b>	CW or CCW									
<b>Sound Pressure Level</b>	75 dB(A)									
<b>Final Colour</b>	RAL 5010									
<b>Paint Specification</b>	2 Pack Epoxy									
<b>Mounting Options</b>	B5 /V3									
<b>Terminal Box Position</b>	Top Terminal Box									

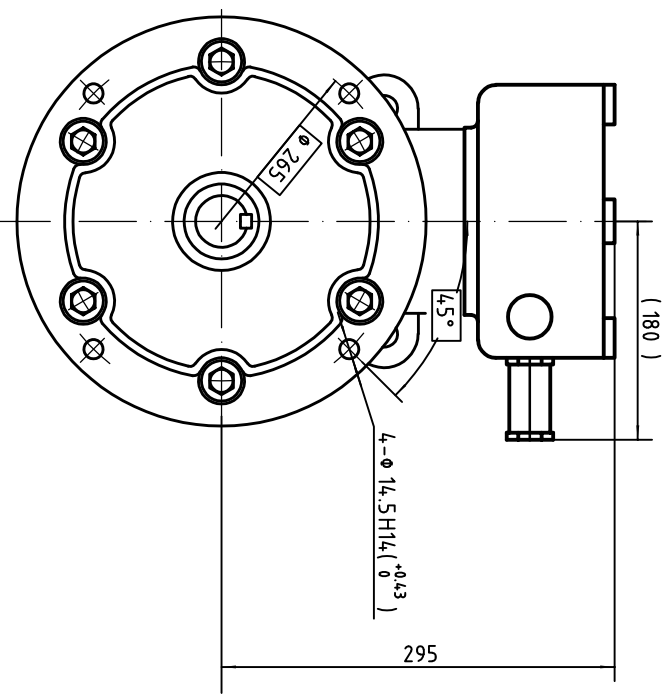
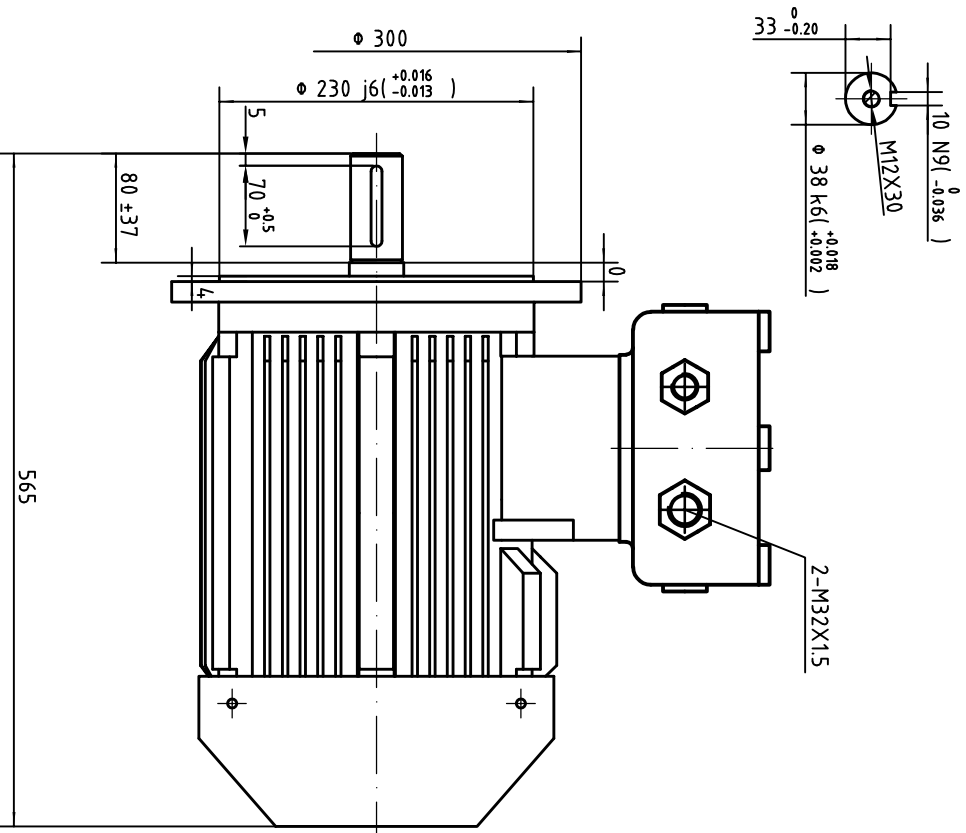

Note: Cable Gland not Included

DRAWING REVISION	REVISION BY	DATE
E00	APPROVED BY	DATE
E00 DESCRIPTION		

COPYRIGHT © MARATHON MOTOR ELECTRIC, INC. ALL RIGHTS RESERVED.  
 MARATHON MOTOR ELECTRIC, INC. CONCEPTS AND DRAWINGS ARE THE PROPERTY OF MARATHON MOTOR ELECTRIC, INC. AND ARE NOT TO BE REPRODUCED OR TRANSMITTED IN ANY FORM OR BY ANY MEANS, ELECTRONIC OR MECHANICAL, INCLUDING PHOTOCOPYING, RECORDING, OR BY ANY INFORMATION STORAGE AND RETRIEVAL SYSTEM, WITHOUT PERMISSION IN WRITING FROM MARATHON MOTOR ELECTRIC, INC.

DRAWN BY	DATE	DESCRIPTION
APPROVED BY	DATE	E3ABL 132M B5
REFERENCE	MATERIAL	PROCESS/FINISH
FIRST ANGLE PROJECTION	SIZE B	DRAWING NUMBER
		SHEET

**marathon**  
Motors

**TORQUE/CURRENT-SPEED DIAGRAM**

<b>Motore / Motor</b>	<b>E3ABL 132M 4</b>	
Potenza nominale / Rated power	7.50	kW
Poli / Pole	4	
Tensione - Frequenza / Voltage - Frequency	400 - 50	V - Hz
Corrente / Rated current	14.43	A
Velocità / Speed	1462	rpm
Coppia / Torque	48.99	Nm

— COPPIA - TORQUE    — CORRENTE - CURRENT

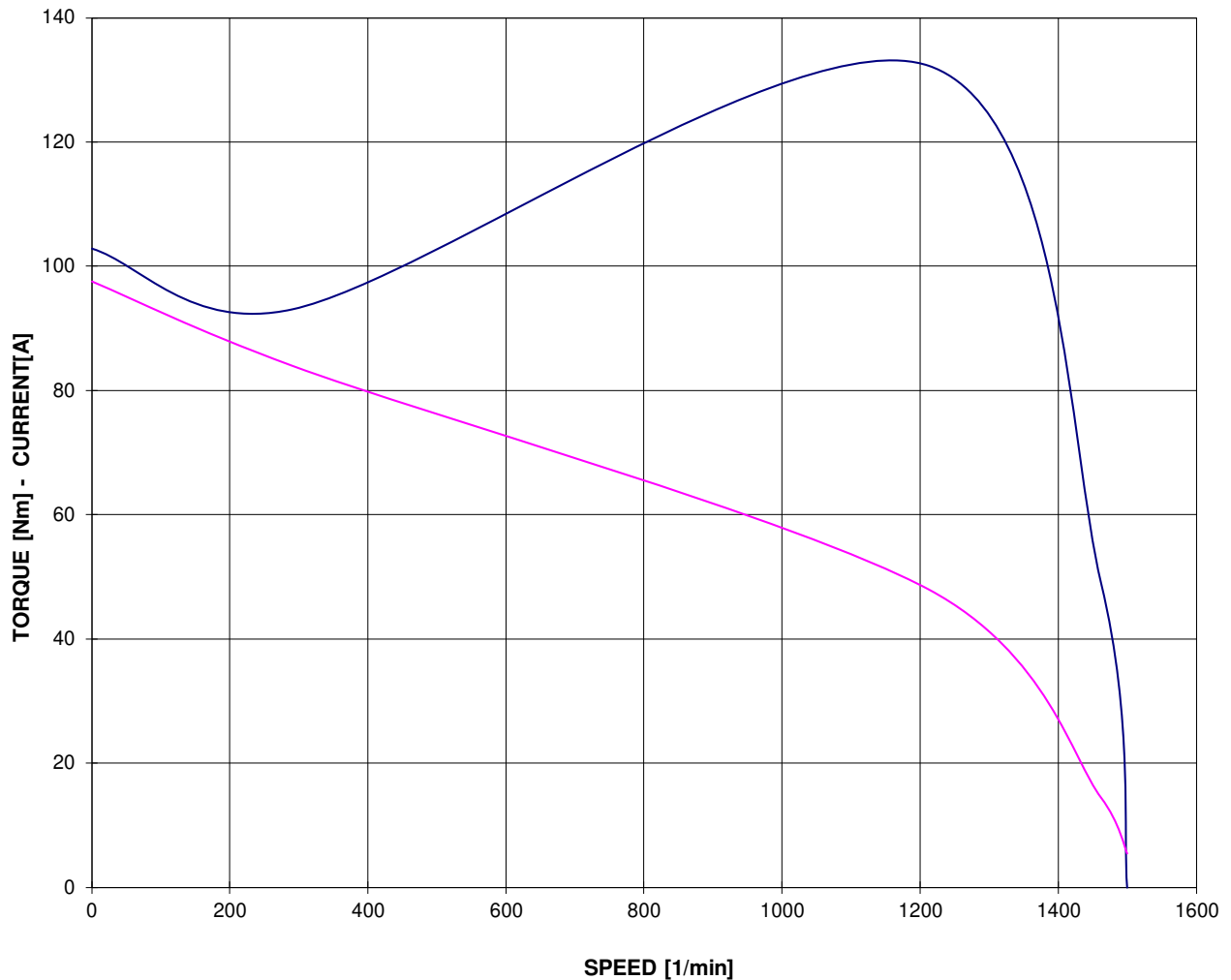

Data obtained by calculation method

**TORQUE/CURRENT-SPEED DIAGRAM (Reduced voltage)**

<b>Motore / Motor</b>	<b>E3ABL 132M 4</b>	
Potenza nominale / Rated power	7.50	kW
Poli / Pole	4	
Tensione - Frequenza / Voltage - Frequency	400 - 50	V - Hz
Corrente / Rated current	14.43	A
Velocità / Speed	1462	rpm
Coppia / Torque	48.99	Nm

— COPPIA - TORQUE                      — CORRENTE - CURRENT  
— COPPIA - TORQUE 80% Un            — CORRENTE - CURRENT 80% Un

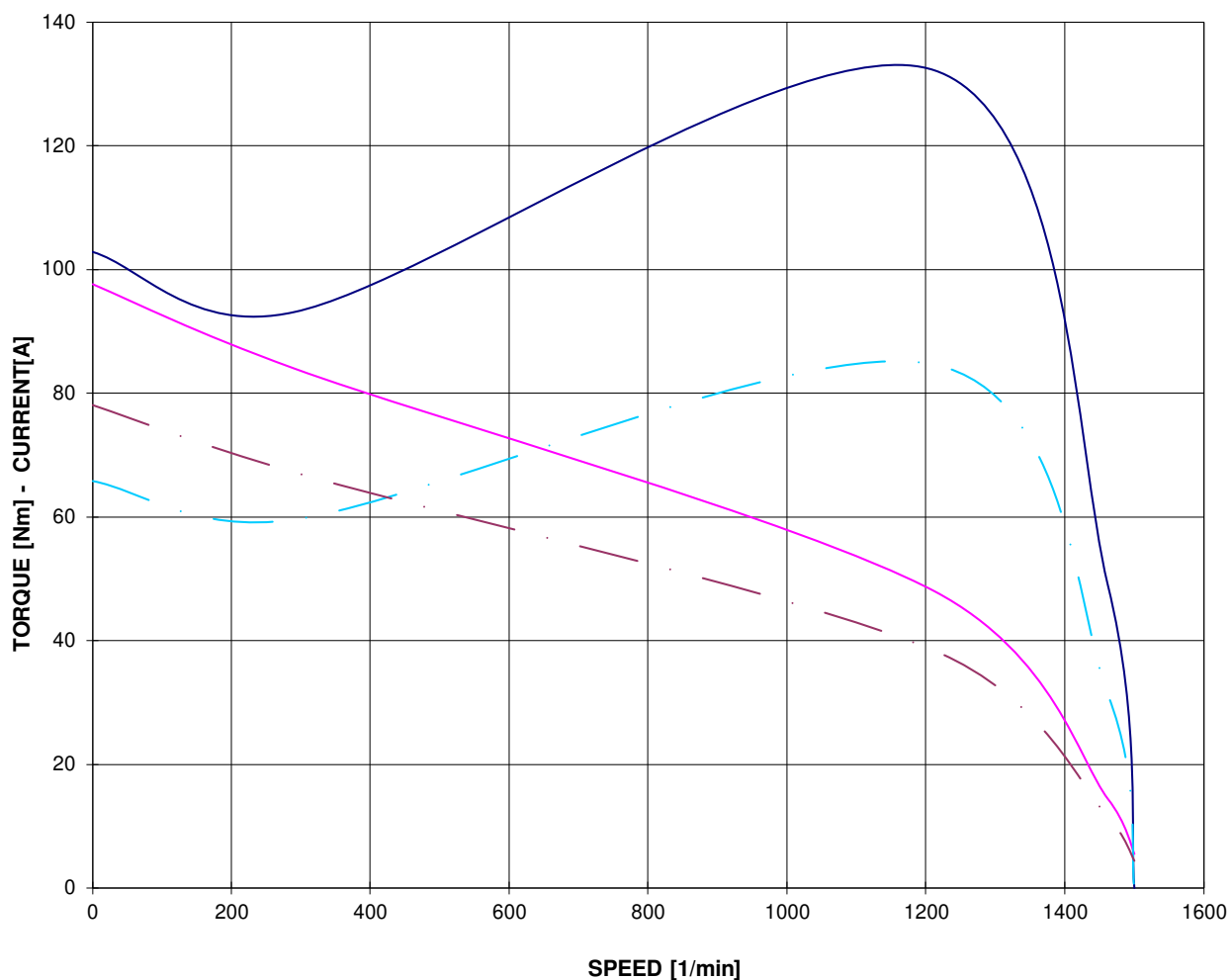

Data obtained by calculation method

**PERFORMANCE CURVES**

<b>Motore / Motor</b>	<b>E3ABL 132M 4</b>	
Potenza nominale / Rated power	7.50	kW
Poli / Pole	4	
Tensione - Frequenza / Voltage - Frequency	400 - 50	V - Hz
Corrente / Rated current	14.43	A
Velocità / Speed	1462	rpm
Coppia / Torque	48.99	Nm

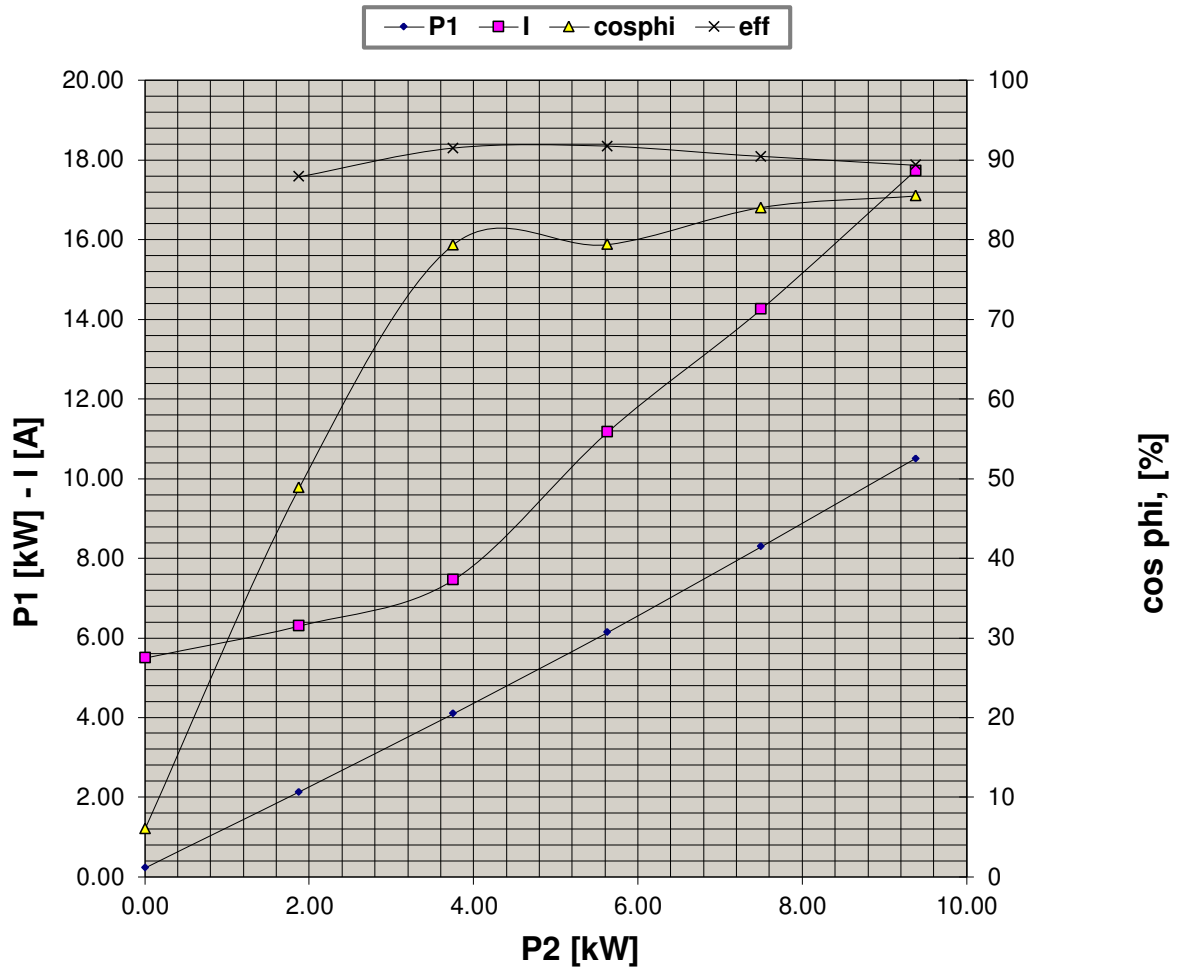

Data obtained by calculation method

**THERMAL WITHSTAND CURVE**

Cliente / Customer 0

Impianto / Plant -  
ITEM -

Numero d'offerta / Offer Number 2024

<b>Motore / Motor</b>	<b>E3ABL 132M 4</b>	
Potenza nominale / Rated power	7.50	kW
Poli / Pole	4	
Tensione - Frequenza / Voltage - Frequency	400 - 50	V - Hz
Corrente / Rated current	14.43	A
Velocità / Speed	1462	rpm
Coppia / Torque	48.99	Nm

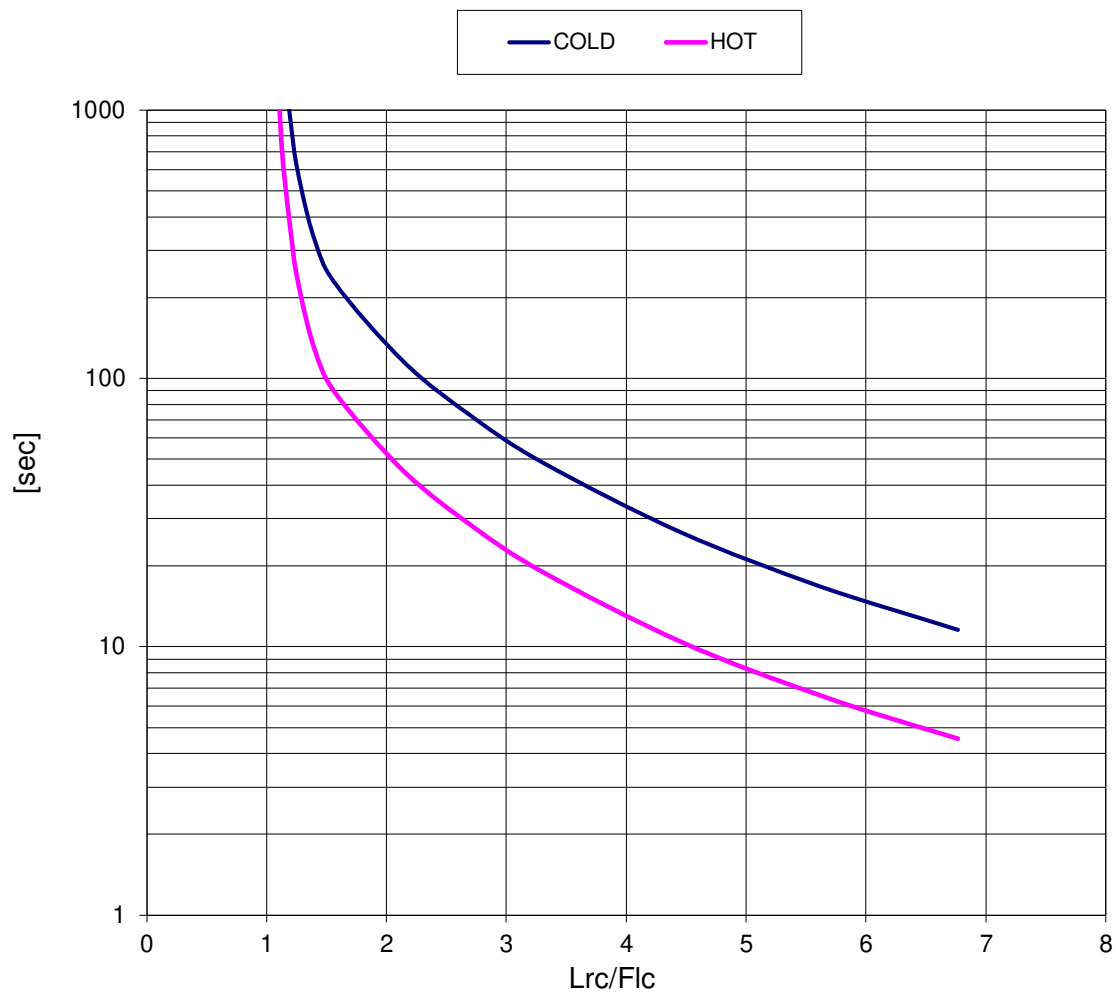

Data obtained by calculation method

**THERMAL WITHSTAND CURVE (Reduced voltage)**

<b>Motore / Motor</b>	<b>E3ABL 132M 4</b>	
Potenza nominale / Rated power	7.50	kW
Poli / Pole	4	
Tensione - Frequenza / Voltage - Frequency	400 - 50	V - Hz
Corrente / Rated current	14.43	A
Velocità / Speed	1462	rpm
Coppia / Torque	48.99	Nm

— COLD (100% Un)   
 — HOT (100% Un)   
 — COLD (80% Un)   
 — HOT (80% Un)

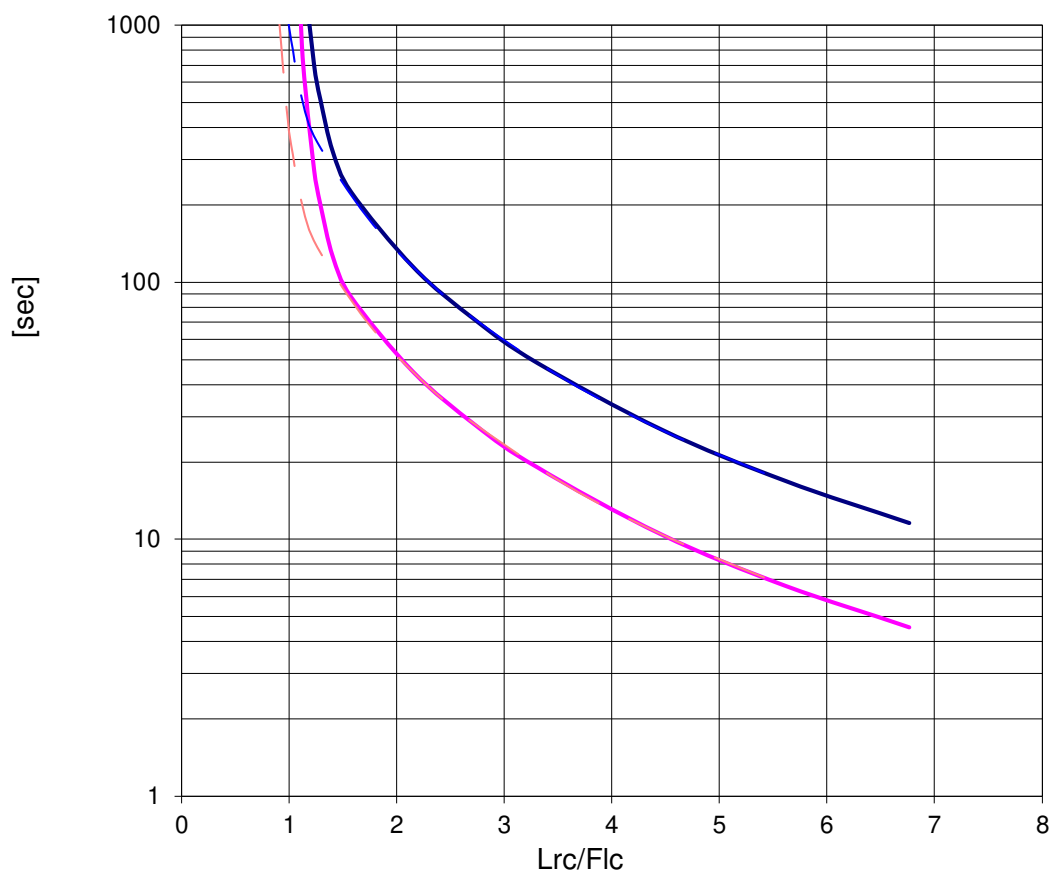

Data obtained by calculation method



Toase-eh Park Sanati Gohar Ofogh  
Petrochemical Co.  
**CONCEPTUAL, BASIC and DETAIL DESIGN  
ENGINEERING OF STYRENE PARK OFFSITE**



Document Title: Belt & Pulley Data Sheet

Document No.: EI027-DMF-VD-ME-DSH-018-R2

Rev. R2

Page 1 of 5

# STYRENE PARK OFFSITE

**Document Title:**  
**Belt & Pulley Data Sheet**

R2	06-10-2024	IFA	F.Aghaienezhad	J.Beigloo	A.Gholizadeh
R1	31-08-2024	IFA	F.Aghaienezhad	J.Beigloo	A.Gholizadeh
R0	22-06-2024	IFA	F.Aghaienezhad	J.Beigloo	A.Gholizadeh
<b>Rev.</b>	<b>Issued Date</b>	<b>DESCRIPTION</b>	<b>PREPARED</b>	<b>CHECKED</b>	<b>APPROVED</b>



Toase-eh Park Sanati Gohar Ofogh  
 Petrochemical Co.  
**CONCEPTUAL, BASIC and DETAIL DESIGN  
 ENGINEERING OF STYRENE PARK OFFSITE**



Document Title: Belt & Pulley Data Sheet





Document No.: EI027-DMF-VD-ME-DSH-018-R2

Rev. R2

Page 2 of 5

**REVISION RECORD SHEET**

Page Page	Revisions							Page	Revisions						
	R0	R1	R2	R3	R4	R5	R6		R0	R1	R2	R3	R4	R5	R6
1	X	X	X					41							
2	X	X	X					42							
3	X	X	X					43							
4	X	X	X					44							
5			X					45							
6								46							
7								47							
8								48							
9								49							
10								50							
11								51							
12								52							
13								53							
14								54							
15								55							
16								56							
17								57							
18								58							
19								59							
20								60							
21								61							
22								62							
23								63							
24								64							
25								65							
26								66							
27								67							
28								68							
29								69							
30								70							
31								71							
32								72							
33								73							
34								74							
35								75							
36								76							
37								77							
38								78							
39								79							
40								80							

 	<b>Toase-eh Park Sanati Gohar Ofogh Petrochemical Co.</b> <b>CONCEPTUAL, BASIC and DETAIL DESIGN ENGINEERING OF STYRENE PARK OFFSITE</b>	 
	Document Title: Belt & Pulley Data Sheet	
	Document No.: EI027-DMF-VD-ME-DSH-018-R2	Rev. R2

DATA SHEET FOR PULLEY BELT TRANSMISSION			
BASIC DATA FOR TRANSMISSIONS			
1	Customer items/DTT items	AIR COOLER	
2	Belt type	V-Belt	
3	Total quantity of belt		2Set
4	Motor power	(KW)	7.5
5	Motor frame size		-
6	Speed motor	(rpm)	1440
7	Speed fan	(rpm)	382
8	Speed ratio		3.76
9	Minimum service factor		1.4
10	Real service factor		1.8
11	Min. Max. Center Distance	(mm)	835 ±85
12	Center distance	(mm)	754.3
13	Belt width<QTY	(mm)	-- /2Set
14	Belt order info		CAPXPA2332
15	Belt drive life	(Hours)	V- belt estimated life~20000
16	Transmitted power	(kW)	13.75
17	Driver	QTY	2
		code	PBT106SPA2
		Pitch Dia	(mm) 106
		Pitch of Groove	(mm) -
		Number of Grooves	2
		Width	-
		Bush no	1610
		Bore	(mm) -
Material/Weight	GG20 /-		
18	Driven	QTY	2
		code	PBT400SPA2
		Pitch Dia	(mm) 400
		Pitch of Groove	(mm) -
		Number of Grooves	2
		Width	-
		Bush no	2517
		Bore	(mm) -
Material/Weight	GG 20 /-		
19	Deflection force	(N)	-
20	Deflection	(mm)	-
21	Maximum tension	(N)	561
22	Noise	dB(A)	85



## INPUT DATA

<b>Transmission type</b>	2 Pulleys power transmission
<b>Product family</b>	NEXT®
<b>Type</b>	Narrow Raw Edge (XPZ,XPA,XPB,XPC)
<b>Section</b>	XPA

<b>Power [kW]</b>	7.50
<b>Speed [RPM]</b>	1440.0
<b>Torque [Nm]</b>	49.7
<b>Required service factor</b>	1.4

## BELT

<b>Code</b>	CAPXPA2332
<b>Length [mm]</b>	2332.00
<b>Number of belts / ribs [-]</b>	2

## RESULT

<b>Resulting service factor</b>	1.8
<b>Transmissible power [kW]</b>	13.75
<b>Linear speed [m/s]</b>	8.0
<b>Center-to-center [mm]</b>	754.3

## PULLEYS

	Solid hub pulley code	Taper bushing code	External	Number of ribs	Pulley diameter [mm]	X [mm]	Y [mm]
<b>Driver</b>	PT106SPA2	PBT106SPA2	No	2	106.00	0	0
<b>Driven</b>	PT400SPA2	PBT400SPA2	No	2	400.00	754.26	0

	Transmission ratio	Speed [RPM]	Wrap angle [°]	Power [kW]	Torque [Nm]	Static shaft load [N]
<b>Driver</b>	--	1440.0	157.5	7.50	49.7	1693.3
<b>Driven</b>	0.26	381.6	202.5	7.50	187.7	1693.3

## TENSIONING

Maximum tension [N]	561	Minimum tension [N]	432
		Vibration frequency method	
Free segment length [mm]		New belt frequency [Hz]	Run-in belt frequency [Hz]
<b>Driver-Driven</b>	739.8	52 ± 2%	46 ± 2%

06 October, 2024

**MESSRS: Damafin Thermal Technology Co.**  
**Iran - Tehran - 14th km of Tehran-Karaj special road –**  
**Iran Khodro South Boulevard - Zamyad Street - No 4**

**Letter of conformity & Declaration of anti-static properties**

**Ref. order: PAE03029, 1158**

Here enclosed we testify that the below mentioned belts:

Item code	Description	Quantity
CAPXPA2332	SIT NEXT® MC NARROW V-BELT Section XPA, Datum length Ld (mm) 2332	8

Are conform to Standards ISO 13050, and are antistatic according to ISO 9563 (Timing belts) and BS3790-1995, ISO 1813: 1998 (E) (V-Belts).

All belts have been inspected according SIT Spa ISO 9001 quality procedure.

Yours Faithfully,

Emiliano Dalla Nave  
Sales Export Manager



SIT S.p.A. 20090 CUSAGO (MI) - Italy  
Viale A. Volta, 2 - Tel. 02.89144.1 (r.a.)  
Fax 02.89144.291 - 02.89144.299



Toase-eh Park Sanati Gohar Ofogh  
Petrochemical Co.  
**CONCEPTUAL, BASIC and DETAIL DESIGN  
ENGINEERING OF STYRENE PARK OFFSITE**



**dttdamafin**  
thermal technology

Document Title: Vibration Switch Data Sheet

Document No.: EI027-DMF-VD-IN-DSH-019-R4

Rev. R4

Page 1 of 8

# STYRENE PARK OFFSITE

**Document Title:  
Vibration Switch Data Sheet**

R4	01-05-2025	IFA	F.Aghaienezhad	J.Beigloo	A.Gholizadeh
R3	02-11-2024	IFA	F.Aghaienezhad	J.Beigloo	A.Gholizadeh
R2	06-10-2024	IFA	F.Aghaienezhad	J.Beigloo	A.Gholizadeh
R1	17-09-2024	IFA	F.Aghaienezhad	J.Beigloo	A.Gholizadeh
R0	22-06-2024	IFA	F.Aghaienezhad	J.Beigloo	A.Gholizadeh
<b>Rev.</b>	<b>Issued Date</b>	<b>DESCRIPTION</b>	<b>PREPARED</b>	<b>CHECKED</b>	<b>APPROVED</b>



Toase-eh Park Sanati Gohar Ofogh  
Petrochemical Co.  
**CONCEPTUAL, BASIC and DETAIL DESIGN  
ENGINEERING OF STYRENE PARK OFFSITE**



Document Title: Vibration Switch Data Sheet





Document No.: EI027-DMF-VD-IN-DSH-019-R4

Rev. R4

Page 2 of 8

**REVISION RECORD SHEET**

Page Page	Revisions						Page	Revisions							
	R0	R1	R2	R3	R4	R5		R6	R0	R1	R2	R3	R4	R5	R6
1	X	X	X	X	X			41							
2	X	X	X	X	X			42							
3	X	X	X	X	X			43							
4		X	X	X	X			44							
5		X	X	X	X			45							
6		X	X	X	X			46							
7		X	X	X	X			47							
8		X	X	X	X			48							
9		X						49							
10								50							
11								51							
12								52							
13								53							
14								54							
15								55							
16								56							
17								57							
18								58							
19								59							
20								60							
21								61							
22								62							
23								63							
24								64							
25								65							
26								66							
27								67							
28								68							
29								69							
30								70							
31								71							
32								72							
33								73							
34								74							
35								75							
36								76							
37								77							
38								78							
39								79							
40								80							

 	<b>Toase-eh Park Sanati Gohar Ofogh Petrochemical Co.</b> <b>CONCEPTUAL, BASIC and DETAIL DESIGN ENGINEERING OF STYRENE PARK OFFSITE</b>	 
	Document Title: Vibration Switch Data Sheet	
	Document No.: EI027-DMF-VD-IN-DSH-019-R4	Rev. R4

Vibration Switch Data sheet										
Basic Data					Manufacturer Data					
1	PROJECT- Customer item	1158			1	Manufacturer / Origin	SAMI/ WIKA/Italy			
2	Quantity	4			2	Type - Model	VBS SPDT without M20*2.5			
3	Tag No.	VS-RU0001A-01A VS-RU0001A-01B VS-RU0001B-01A VS-RU0001B-01B			3	Enclosure material	Cast aluminum painted			
4	Area classification	IEC	Yes			4	Certification	According to 2014/34/EU ATEX Exd IIC T5		
5		NEMA	Yes			5	Working	HORIZONTAL	Yes	VERTICAL
6	Enclosure	Exd			6	Wiring entry(type-size)	M20			
7	Reset	Electric	NO	Manual	YES	7	CABLE GLAND	M20*1.5		
8	Switch contacts	SPDT	YES	DPDT	NO	8	RANGE	0-5g		
9	Protection	IP 65			9	TEMP CLASS	T5			
10	Zone - Gas group	2			10	Normal Operation Temp	(-20, 55) °C			
11	RANGE - SET POINT	(0- 5 g)								
12	Temperature class	IIB-T3			11	Set point adjust	2g			
13	Ambient temp. min/max	(5 To 48) °C			12	RESET	MANUAL			
14	Humidity (RH) (%)	80%			13	PROTECTION	IP65			
15	Altitude (m)	20			14	Installation	With fixing base or bracket. The vibration sensitive axle is perpendicular or axial to the switch fixing base			
16	Contact rating	24VDC, 1A			15					
17	Start-up delay	N.A			16					
18	MOUNTING	Yes			17					
19	Housing	CAST ALUMINIUM			18					
20	Thered size - TYPE	M20 @ 1.5			19					

# Compact vibration switch, flameproof enclosure Ex D Model VBS

WIKA data sheet PR XX.XX



for further approvals see  
page 4

## Applications

- Monitor excess of vibrations in machinery equipments
- Safety-critical applications in chemical and petrochemical industries, oil and gas, power generation, including nuclear power plants, water/wastewater, mining
- Ventilation / Air conditioning
- Pumps & compressors, turbines
- Engines, motors & generators

## Special features

- Robust switch enclosure from aluminium alloy
- Frequency sensitivity up to 60 Hz (< 3600 RPM)
- SPDT or DPDT contacts, up to AC 380 Vac, 15 A
- Calibration: up to 5 g with outer calibration screw

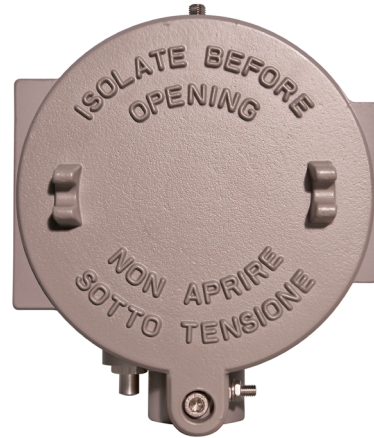

Model VBS

## Description

The Vibration switches have been developed to protect the rotating equipments against increase in vibration due to operating anomalies or failures that could damage the entire machinery.

The high quality of the products and manufacturing in accordance with ISO 9001 ensure reliable monitoring of your machine. During the production phase the switches are 100% calibrated and tested.

The switches are of mechanical type. The robust switch enclosure from aluminium alloy can withstand the rough and corrosive operating conditions of the process industry.

To adjust the set point simply open the access cover plate. The access to the terminal block for the electrical connection is protected by a screw-on lid, which is secured with a screw-

type lock against unauthorised intervention.

The vibration switches have a frequency sensitivity up to 60Hz and can be calibrated up to 5g acceleration directly in field.

Vibrations Switches contain a spring inside the body.

The excessive vibration, beyond a defined range, causes the movement of the spring, which consequently activates the switch through magnetic attraction.

The position of the magnet in relation to the spring can be changed to match the desired threshold value.

Disengaging the magnet from the spring will reset the Vibration Switch.

In order to ensure operation as flexible as possible, the Vibration switches are fitted with micro switches which enable the switching of an electrical load of up to AC 380V 15A directly.

## Specifications

Specifications	
<b>Enclosure material</b>	High resistance aluminium alloy. Max copper content: 1%
<b>Ignition protection</b>	CESI Flameproof, Ex d IIC T6 or T5 Gb
<b>Switch enclosure</b>	Epoxy resin coated and tamper-proof junction box and terminal box provided together with the equipment
<b>Peak vibration range</b>	5 g
<b>Calibration</b>	0 to 5g with outer calibration screw <sup>1)</sup>
<b>Frequency sensitivity</b>	0 to 60 Hz (0 ÷ 3600 RPM)
<b>Mechanical protection</b>	IP 65 & CE mark
<b>Working axes</b>	2 Axis only (A-B see picture)
<b>Ambient Temperature</b>	<ul style="list-style-type: none"> <li>■ -20°C +40°C for temperature class T6</li> <li>■ -20°C +55°C for temperature class T5</li> </ul>
<b>Capacity of contacts</b>	<ul style="list-style-type: none"> <li>■ SPDT 15A @ 0÷380 Vac</li> <li>■ DPDT 10A @ 0÷250 Vac</li> </ul>
<b>Start-up delay</b>	Optional reset coil required <sup>2)</sup>
<b>Reset</b>	<ul style="list-style-type: none"> <li>■ Local reset is provided as standard</li> <li>■ Electrical Remote Reset can be supplied as optional</li> </ul>
<b>Weight</b>	3 kg (including bracket and fixing screws)
<b>Earth screws</b>	Internal and external
<b>Terminal box</b>	Suitable for cable up to 2,5 mm <sup>2</sup>
<b>Installation</b>	With fixing base or bracket. The vibration sensitive axle is perpendicular or axial to the switch fixing base
<b>Label</b>	Laser-engraved stainless steel nameplate fixed to the body, containing the following information: <ul style="list-style-type: none"> <li>■ Manufacturer name</li> <li>■ Model</li> <li>■ Serial Number</li> <li>■ Range</li> <li>■ Purchase Order number</li> <li>■ Tag number</li> </ul>
<b>Reset coil</b>	<ul style="list-style-type: none"> <li>■ None</li> <li>■ 115/120 Vac</li> <li>■ 220/230 Vac</li> <li>■ 24 Vdc</li> </ul>
<b>Electrical connection</b>	<ul style="list-style-type: none"> <li>■ M20 X 1,5</li> <li>■ ¾" NPT-F</li> <li>■ 1/2" NPT-F</li> </ul>
<b>Switch contacts</b>	<ul style="list-style-type: none"> <li>■ SPDT</li> <li>■ DPDT</li> </ul>

<sup>1)</sup> The vibration switches are provided with a standard pre-set factory set-point. The set-point of the instrument strongly depends on the intensity of the natural vibration produced by the equipment during the normal operation. The final calibration of the vibration switch must be done on field according to the peculiarity of machinery on which the device is installed. For this reasons, due to the huge variables that depend on the equipment and application, WIKA does not provide any customized set-point or any calibration certificate of the instrument.

<sup>2)</sup> Apply voltage to the reset coil to stop bounces for at least 20 seconds after the machine has started

# Dimensions

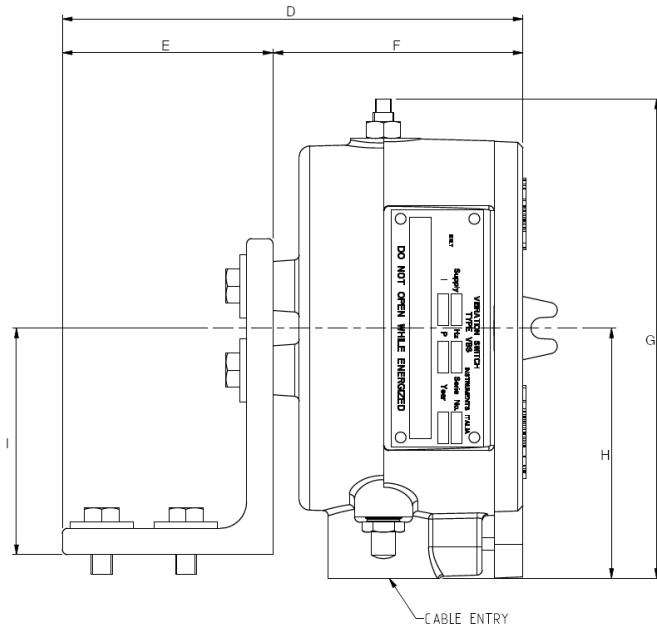
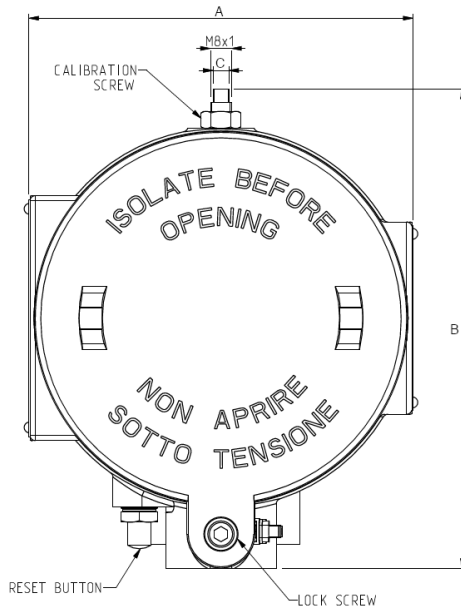

Dimensions in mm [in]								
A	B	C	D	E	F	G	H	I
146 [5.75]	182 [7.16]	6 [0.24]	175 [6.89]	80 [3.15]	95 [3.74]	182 [7.16]	95 [3.74]	86 [3.38]

Single Switch Connection Electrical Diagram

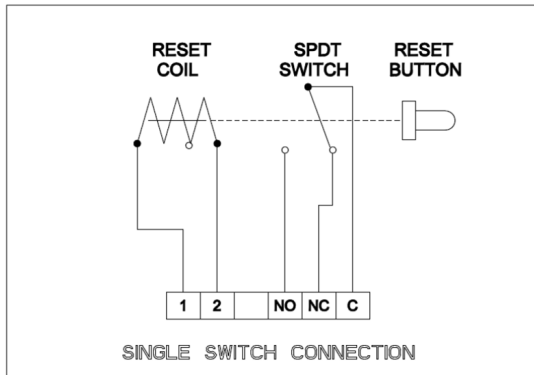

Double Switch Connection Electrical Diagram

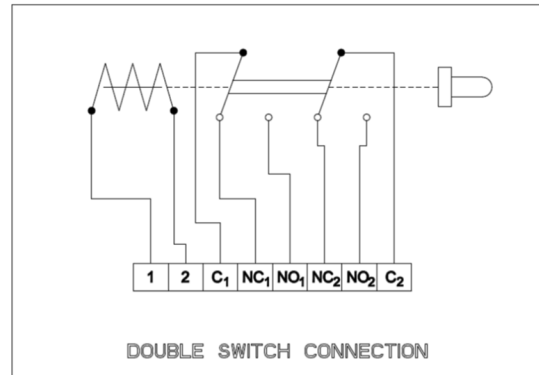

## Ordering Information

Item Number	Reset coil	Switch contacts	Electrical connections
81647076	24 VDC	DPDT	¾" NPT-F + ½" NPF-F adapter
81647079	24 VDC	DPDT	¾" NPT-F direct
81647080	24 VDC	DPDT	M20x1,5 + Cable gland 11-18mm adapter
81647083	24 VDC	DPDT	M20x1,5 direct
81647077	24 VDC	SPDT	¾" NPT-F + ½" NPF-F adapter
81647078	24 VDC	SPDT	¾" NPT-F direct
81647081	24 VDC	SPDT	M20x1,5 + Cable gland 11-18mm adapter
81647082	24 VDC	SPDT	M20x1,5 direct
81647168	110 VAC	DPDT	¾" NPT-F + ½" NPF-F adapter
81647165	110 VAC	DPDT	¾" NPT-F direct
81647087	110 VAC	DPDT	M20x1,5 + Cable gland 11-18mm adapter
81647084	110 VAC	DPDT	M20x1,5 direct
81647167	110 VAC	SPDT	¾" NPT-F + ½" NPF-F adapter
81647166	110 VAC	SPDT	¾" NPT-F direct
81647086	110 VAC	SPDT	M20x1,5 + Cable gland 11-18mm adapter
81647085	110 VAC	SPDT	M20x1,5 direct
81647170	220 VAC	DPDT	¾" NPT-F + ½" NPF-F adapter
81647173	220 VAC	DPDT	¾" NPT-F direct
81647174	220 VAC	DPDT	M20x1,5 + Cable gland 11-18mm adapter
81647177	220 VAC	DPDT	M20x1,5 direct
81647171	220 VAC	SPDT	¾" NPT-F + ½" NPF-F adapter
81647172	220 VAC	SPDT	¾" NPT-F direct
81647175	220 VAC	SPDT	M20x1,5 + Cable gland 11-18mm adapter
81647176	220 VAC	SPDT	M20x1,5 direct
81647072	Without	DPDT	¾" NPT-F + ½" NPF-F adapter
81647068	Without	DPDT	¾" NPT-F direct
81647074	Without	DPDT	M20x1,5 + Cable gland 11-18mm adapter
81647071	Without	DPDT	M20x1,5 direct
81647073	Without	SPDT	¾" NPT-F + ½" NPF-F adapter
81647069	Without	SPDT	¾" NPT-F direct
81647075	Without	SPDT	M20x1,5 + Cable gland 11-18mm adapter
81647070	Without	SPDT	M20x1,5 direct

## Approvals

Logo	Description	Country
CE	<ul style="list-style-type: none"><li>- EU Declaration of conformity</li><li>- RoHS directive</li><li>- ATEX directive</li><li>- II 2G</li></ul>	European Union

Approvals and certificates, see website

© 04/2021 WIKA Alexander Wiegand SE & Co. KG, all rights reserved.  
The specifications given in this document represent the state of engineering at the time of publishing.  
We reserve the right to make modifications to the specifications and materials.





Toase-eh Park Sanati Gohar Ofogh  
Petrochemical Co.  
**CONCEPTUAL, BASIC and DETAIL DESIGN  
ENGINEERING OF STYRENE PARK OFFSITE**



**dttdamafin**  
thermal technology

Document Title: VFD Data Sheet

Document No.: EI027-DMF-VD-EL-DSH-042

Rev. R0

Page 1 of 6

# STYRENE PARK OFFSITE

**Document Title:  
VFD Data Sheet**

Rev.	Issued Date	DESCRIPTION	PREPARED	CHECKED	APPROVED
R0	17-09-2024	IFA	F.Aghaienezhad	J.Beigloo	A.Gholizadeh



Toase-eh Park Sanati Gohar Ofogh  
 Petrochemical Co.  
**CONCEPTUAL, BASIC and DETAIL DESIGN  
 ENGINEERING OF STYRENE PARK OFFSITE**



Document Title: VFD Data Sheet

Document No.: EI027-DMF-VD-EL-DSH-042

Rev. R0

Page 2 of 6

**REVISION RECORD SHEET**

Page Page	Revisions							Page	Revisions						
	R0	R1	R2	R3	R4	R5	R6		R0	R1	R2	R3	R4	R5	R6
1	X							41							
2	X							42							
3	X							43							
4	X							44							
5	X							45							
6	X							46							
7								47							
8								48							
9								49							
10								50							
11								51							
12								52							
13								53							
14								54							
15								55							
16								56							
17								57							
18								58							
19								59							
20								60							
21								61							
22								62							
23								63							
24								64							
25								65							
26								66							
27								67							
28								68							
29								69							
30								70							
31								71							
32								72							
33								73							
34								74							
35								75							
36								76							
37								77							
38								78							
39								79							
40								80							



PRODUCT-DETAILS

# ACS880-01-025A-3

## LV AC industrial wall-mounted single drive, IEC: Pn 11 kW, 25 A, 400 V (ACS880-01-025A-3)



General Information	
Global Commercial Alias	ACS880-01-025A-3
Product ID	3AUA0000107992
ABB Type Designation	ACS880-01-025A-3
EAN	6438177557197
Catalog Description	LV AC industrial wall-mounted single drive, IEC: Pn 11 kW, 25 A, 400 V (ACS880-01-025A-3)
Long Description	<p>The ACS880-01 drives are customized to meet the particular needs of specific industries, such as oil and gas, mining, metals, chemicals, cement, power plants, material handling, pulp and paper, sawmills, marine, water and wastewater, food and beverage, and automotive. They can control a wide range of applications, including cranes, extruders, winches, winders, conveyors, mixers, compressors, centrifuges, test benches, elevators, extruders, pumps and fans.</p> <p>The ACS880-01 comes in one compact package for easy installation and commissioning. The drive can be installed on the wall as standard and in a cabinet as an option. The drive offering includes enclosure classes up to IP55, making it suitable for most environments and installations. ACS880-01 drives have all the essential features built-in. These features include as standard a choke for harmonic filtering as well as options like a brake chopper, EMC filter and communication protocol adapter, functional safety, external output filters and I/O extension modules.</p>

### Ordering

Country of Origin	Finland (FI)
Customs Tariff Number	85044085
HS Code	850440-- Electrical transformers, static converters (for example, rectifiers) and inductors.- Static converters
Invoice Description	ACS880-01-025A-3 PN: 11.0 kW, IN: 25 A
Made To Order	Yes
Minimum Order Quantity	1 piece
Order Multiple	1 piece
Quote Only	No
Selling Unit of Measure	piece

## Dimensions

Product Net Weight	8.4 kg 18.519 lb
Product Net Depth / Length	249 mm 9.803 in
Product Net Height	409 mm
Product Net Width	155 mm 6.102 in
Package Level 1 Depth / Length	574 mm
Package Level 1 Height	304 mm
Package Level 1 Width	256 mm
Package Level 1 Units	1 carton

## Technical

Number of Phases	3
Degree of Protection	IP21
Enclosure Type NEMA	Type1
Altitude	4000 m 5 ... 95
Sound dB (A)	59 dB(A)
Multiple Battery Information	Lithium Coin, CR2032, 220 mAh, 3 V, 2 pcs, 6 g
Frequency (f)	47.5 ... 63 Hz
Frame Size	R2
Input Voltage (U <sub>in</sub> )	380 ... 415 V
Mounting Type	Wall-mounted
Communication Protocol	CAN DeviceNet EtherNet/IP MODBUS Other Bus Systems PROFIsafe PROFIBUS PROFINET IO
Number of Hardware Interfaces	Industrial Ethernet 0 Other 4 Parallel 0 PROFINET 0 RS-232 0 RS-422 0 RS-485 1 Serial TTY 0 USB 1
Includes	Control unit PC connection
Analog Inputs	2
Analog Outputs	2
Number of Digital In/Outputs	6 / 2

Output Current, Heavy-Duty Use ( $I_{HD}$ )	17 A
Output Current, Light-Overload Use ( $I_{LD}$ )	24 A
Output Current, Normal Use ( $I_n$ )	25 A
Output Power, Heavy-Duty Use ( $P_{HD}$ )	7.5 kW
Output Power, Light-Overload Use ( $P_{LD}$ )	11 kW
Output Power, Normal Use ( $P_n$ )	11 kW
Apparent Power Output	17 kV·A
Efficiency Level	IE2
Standby Loss	23 W
Complete Drive Module Efficiency (61800-9-2)	

Operating Point Frequency / Current	Absolute Loss	Relative Loss	Efficiency
0 / 25 %	126 W	0.7 %	87.9 %
0 / 50 %	168 W	1.0 %	91.3 %
0 / 100 %	301 W	1.7 %	92.2 %
50 / 25 %	135 W	0.8 %	93.4 %
50 / 50 %	185 W	1.1 %	95.2 %
50 / 100 %	342 W	2.0 %	95.6 %
90 / 50 %	203 W	1.2 %	97.0 %
90 / 100 %	412 W	2.4 %	97.0 %

Temperature Rating Maximum 40 °C

### Classifications

ETIM 8	EC001857 - Frequency converter =< 1 kV
ETIM 9	EC001857 - Frequency converter =< 1 kV
UNSPSC	39122001

### Environmental

SCIP	090be974-b30f-4eaa-b924-275d6a7f6686 Finland (FI)
Simplified SCIP	05ba9c4c-0f14-4b63-8f0d-9dfe97cea5ce Belgium (BE)
	fe7f4acc-a128-4e0d-bb0e-9401a4fbb99c Netherlands (NL)
	c8260a35-2ae0-4c51-8f1f-f45f223f38d1 Denmark (DK)
	2ba4b589-d362-4a71-960c-db11fa23c371 Spain (ES)
	16d426ed-87d2-41b8-a6a6-becce45ad9b6 Portugal (PT)
	83eb23c1-e520-4509-b458-e0f3f5d3e025 Estonia (EE)

WEEE Category 5. Small Equipment (No External Dimension More Than 50 cm)

### Additional Information

Product Name	Frequency converter
--------------	---------------------

---

## Categories

---

Drives → Low Voltage AC Drives → Industrial Drives → ACS880 single drives → ACS880-01 - Wall-mounted single drive

