



Toase-eh Park Sanati Gohar Ofogh
Petrochemical Co.
**CONCEPTUAL, BASIC and DETAIL DESIGN
ENGINEERING OF STYRENE PARK OFFSITE**



Document Title: Compressor Package Outline Drawing

Document No.: EI027-HSE-VD –ME–DWG–002- R0

Rev. R0

Page 1 of 3

STYRENE PARK OFFSITE

Document Title:

Compressor Package Outline Drawing

Comments:

- 1) Part List Schedule with Numbering Procedure to be added .
- 2) All Dimensions in side view , Top View to be considered.
- 3) Overall Dimensions to be submitted.
- 4) Weight with Active Part , Shipping , Total to be submitted.

R0	03-02-2024	IFA	F.SH	M.O	A.M
Rev.	Issued Date	DESCRIPTION	PREPARED	CHECKED	APPROVED



Toase-eh Park Sanati Gohar Ofogh
Petrochemical Co.
**CONCEPTUAL, BASIC and DETAIL DESIGN
ENGINEERING OF STYRENE PARK OFFSITE**



Document Title: Compressor Package Outline Drawing

Document No.: EI027-HSE-VD –ME–DWG–002- R0

Rev. R0

Page 2 of 3

REVISION RECORD SHEET

Page Page	Revisions							Page	Revisions						
	R0	R1	R2	R3	R4	R5	R6		R0	R1	R2	R3	R4	R5	R6
1	X							41							
2	X							42							
3	X							43							
4								44							
5								45							
6								46							
7								47							
8								48							
9								49							
10								50							
11								51							
12								52							
13								53							
14								54							
15								55							
16								56							
17								57							
18								58							
19								59							
20								60							
21								61							
22								62							
23								63							
24								64							
25								65							
26								66							
27								67							
28								68							
29								69							
30								70							
31								71							
32								72							
33								73							
34								74							
35								75							
36								76							
37								77							
38								78							
39								79							
40								80							

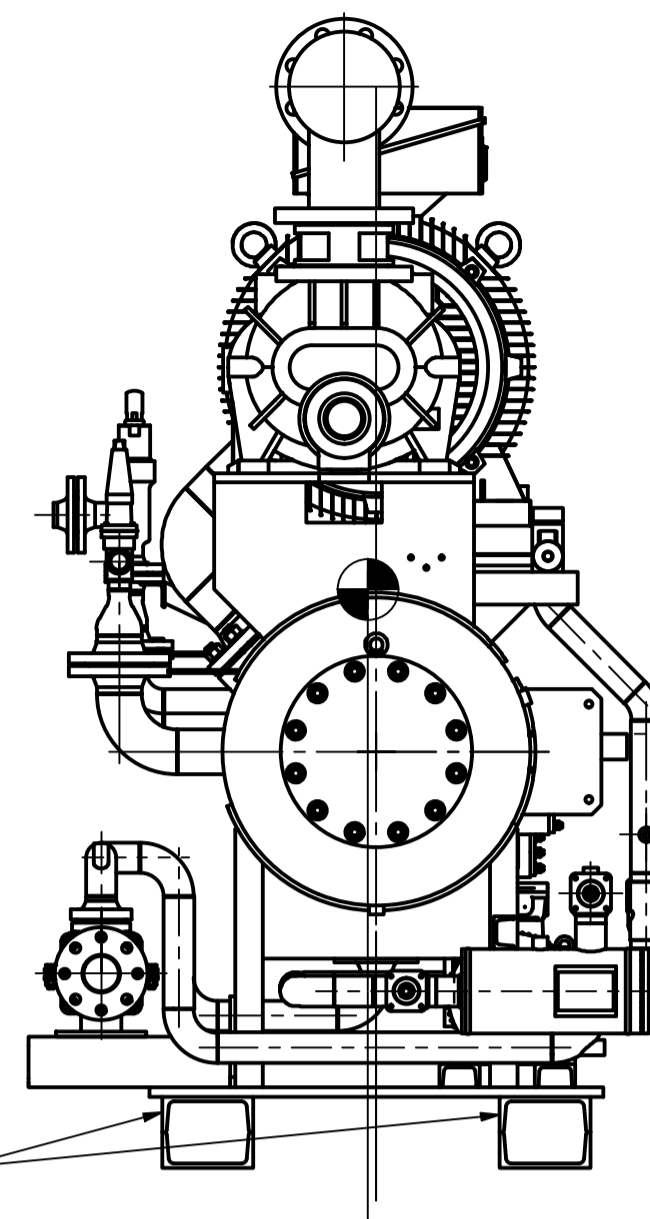
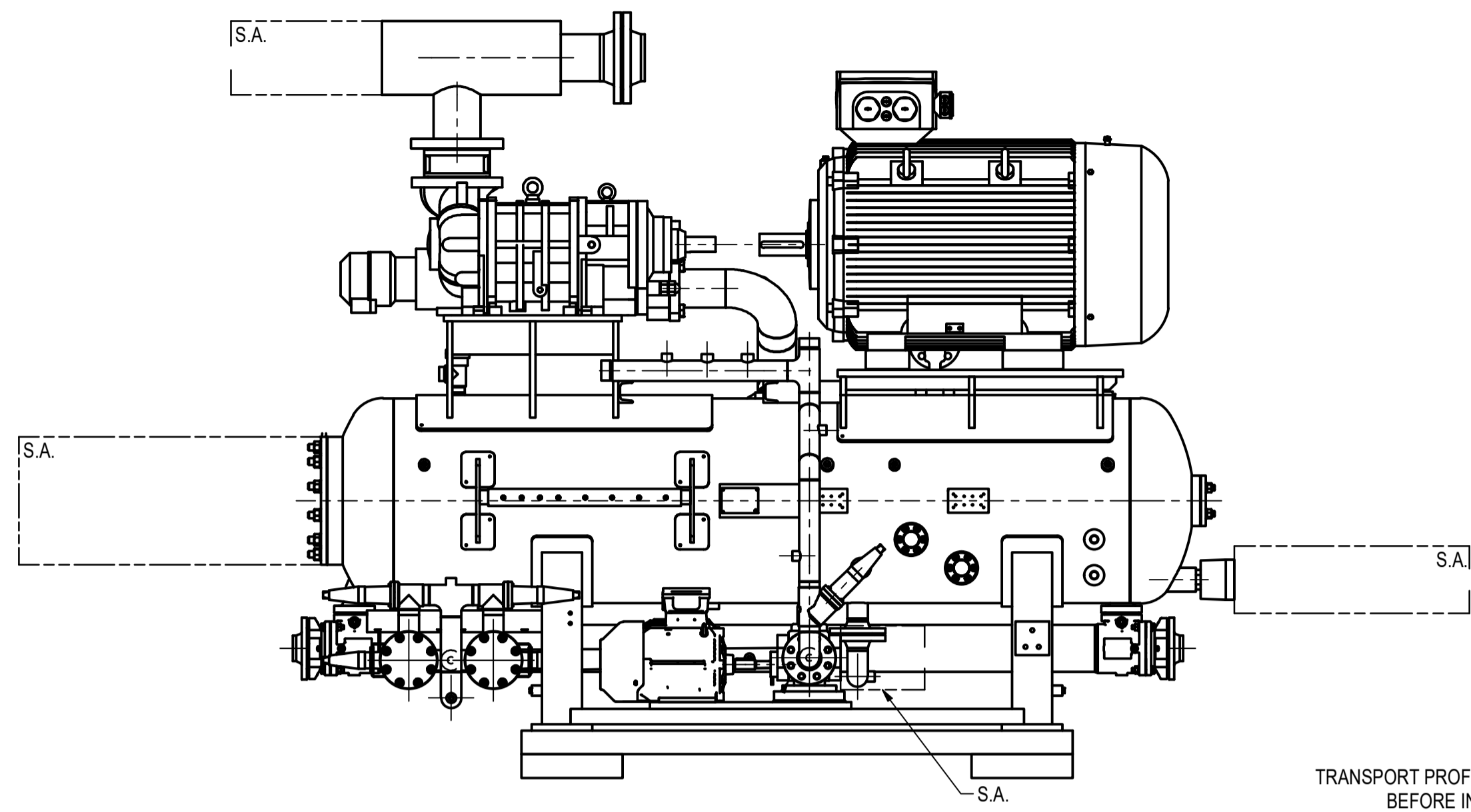

TRANSPORT PROFILES, REMOVE BEFORE INSTALLATION!

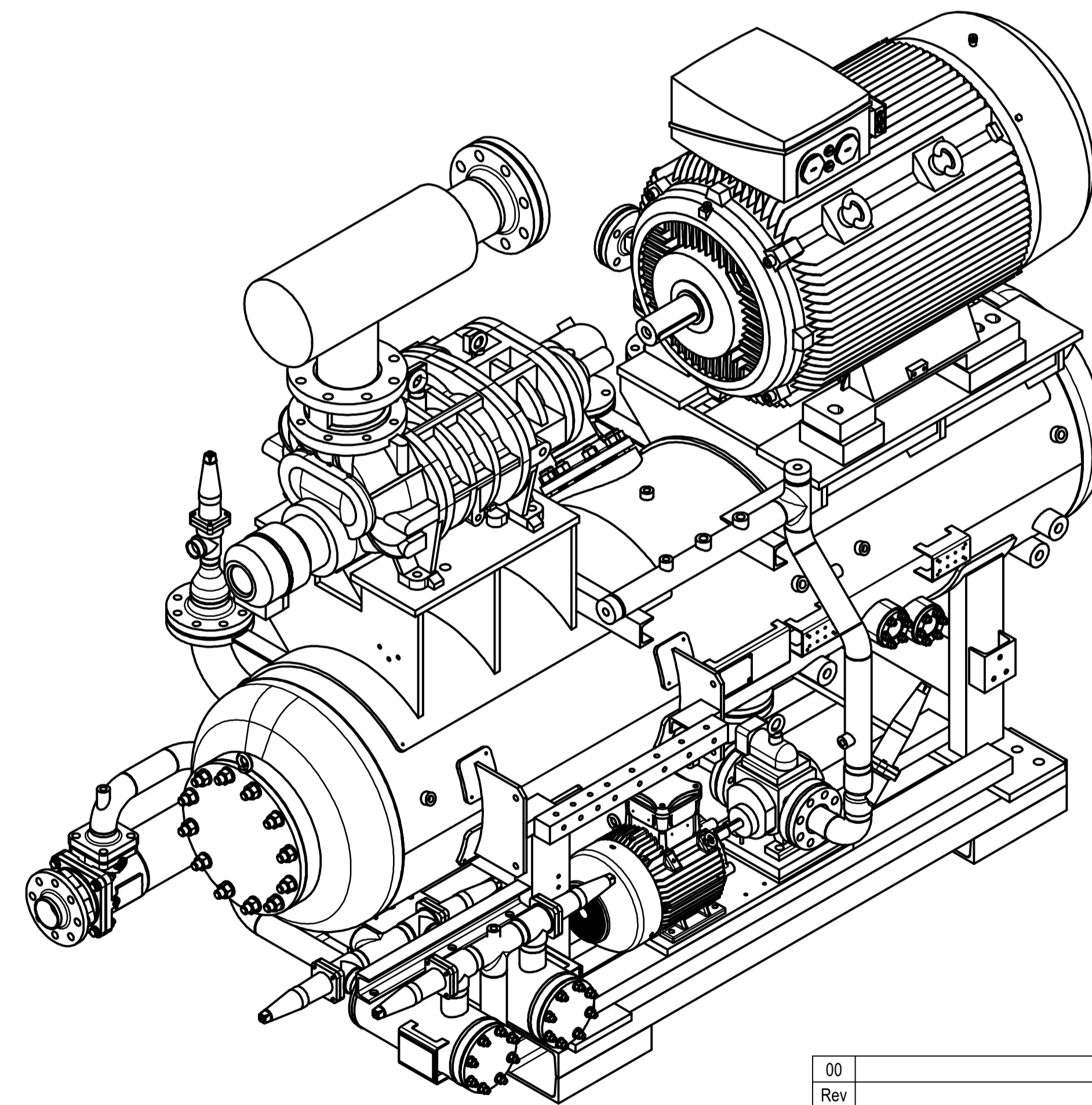
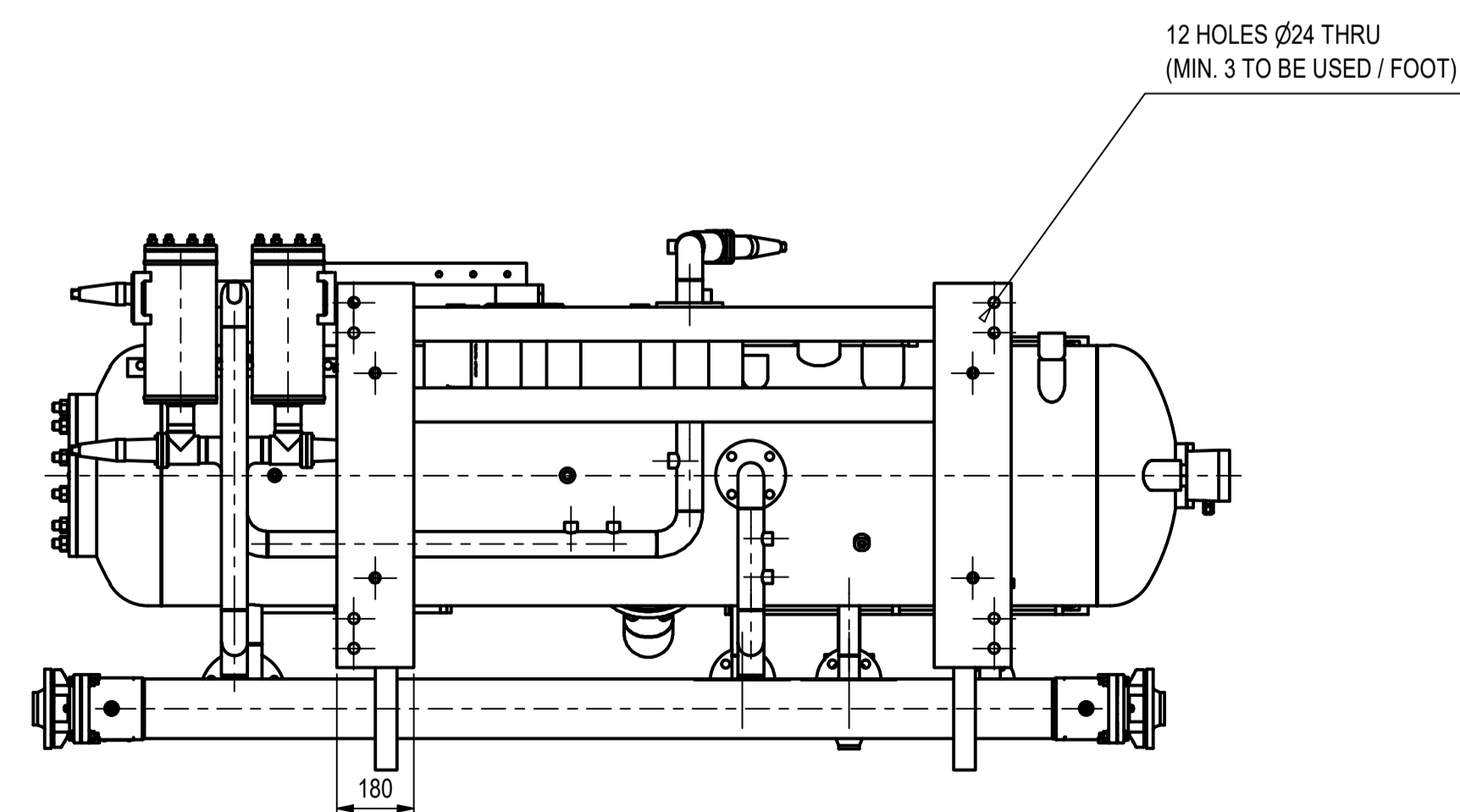
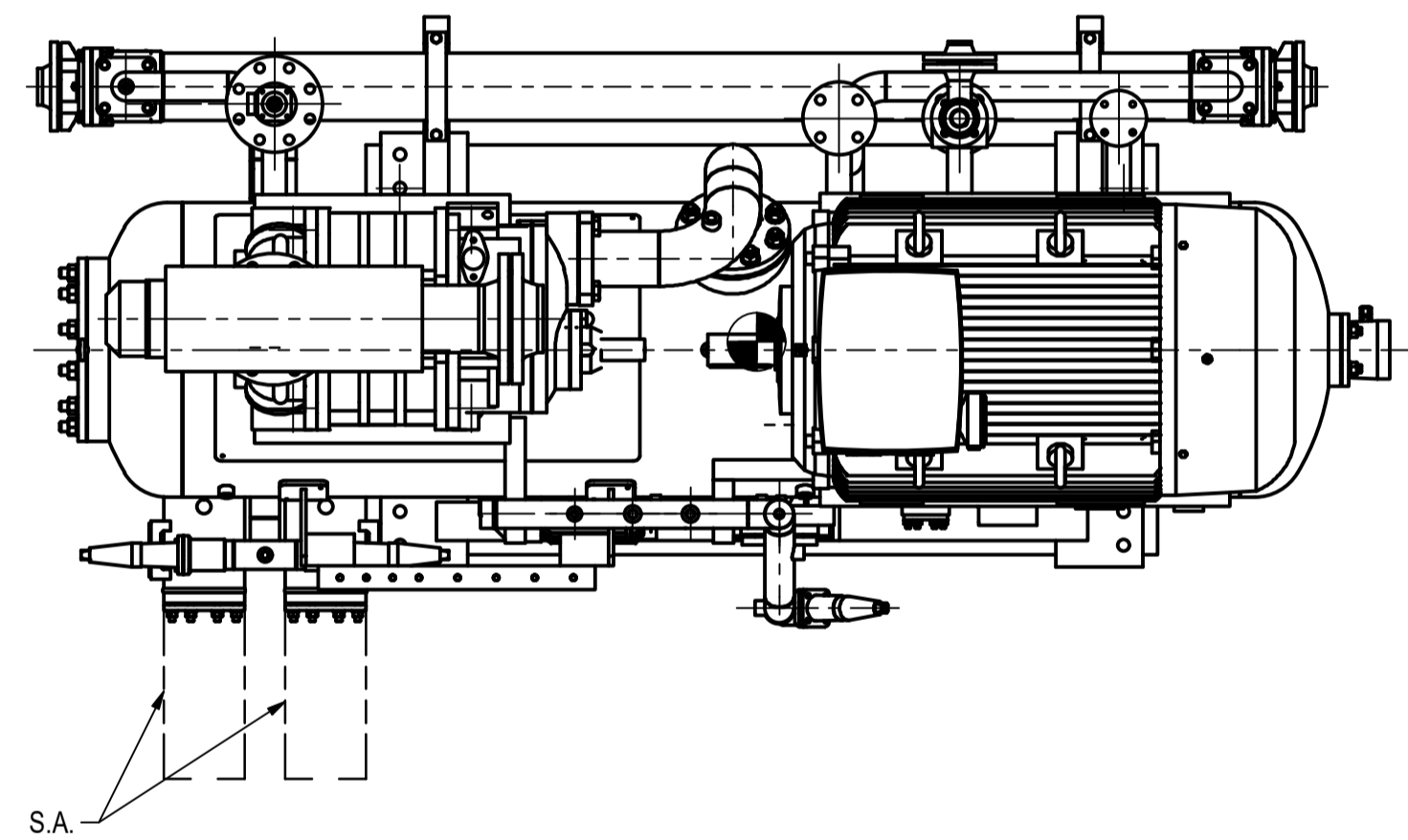
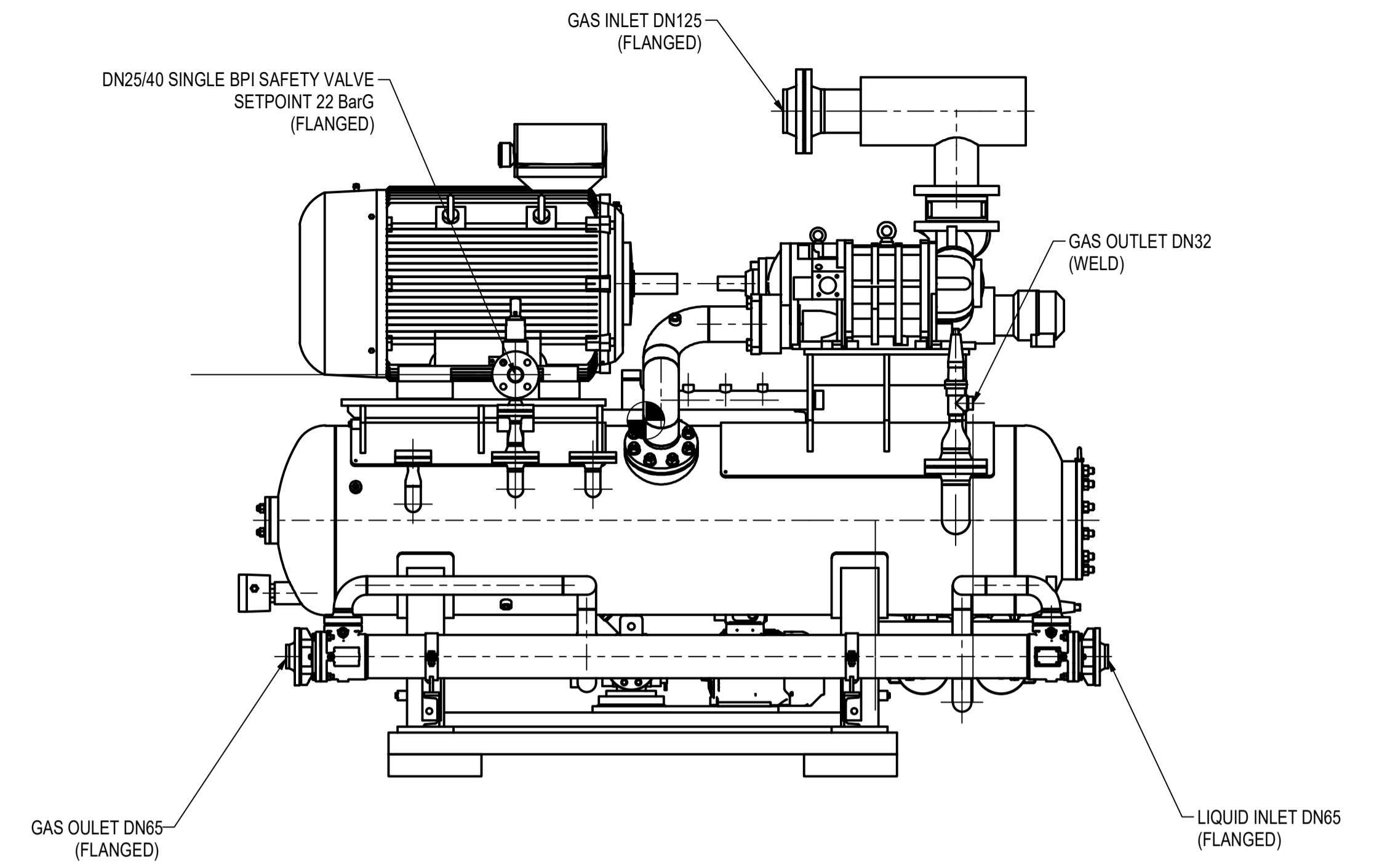

S.A. = SERVICE AREA

= CENTER OF GRAVITY

For more accurate transport dimensions, please contact Mayekawa Europe one week in advance of foreseen shipment date.

Weight information (Approx.):

Empty weight (kg): 3300 Max. operating weight (kg): 3500

Paint information:

Unit color (RAL): 7035 Motor in the unit color: Yes No

Paint system:

00	First issue	JCR	MEM	29/01/2024
Rev	Description	Drw	App	Date App

Revision table

MAYEKAWA	MAYEKAWA EUROPE N.V. Leuvensesteenweg, 605 1930 Zaventem - Belgium	Customer: Proj. nr.: Proj. name: Ext. dwg. nr.:	Ext. Rev.:
-----------------	--	--	------------

Status: **Released**

General arrangement for customer

Drawn: JCR 29/01/2024	Checked: MEM 31/01/2024	Approved:	Eng:	Scale: 1:15	Replaces:
GLOVA Code				Size: A1	Sheet: 1 of 1
<small>Unless mentioned, all dimensions in mm Rc = Int. BSPT taper (ISO 7) Rp = Int. BSPT parallel (ISO 7) R = Ext. BSPT (ISO 7)</small>					Rev: 00

THIS DOCUMENT MUST BE TREATED AS CONFIDENTIAL. IT MUST NOT BE COPIED, DISTRIBUTED TO OTHERS OR ITS CONTENTS BE USED OR COMMUNICATED EITHER IN WHOLE OR IN PART WITHOUT PERMISSION OF MAYEKAWA EUROPE N.V. ALL RIGHTS ARE RESERVED.