

NOTES

1. UNLESS OTHERWISE NOTED ALL DIMENSIONS ARE IN MILLIMETERS.

* FOR ONE SET					
PART NO.	PART NAME	MATERIAL	REGULAR QUANTITY	SPARE QUANTITY	REMARK
3	GUIDE RAIL	SAS16-70M	2		t12 x 63.7 x 1412
2	GUIDE RAIL	SAS16-70M	2		t12 x 28.4 x 1412
1	FULL SUPPORT	SAS16-70	4		t10 x #595.2

BILL OF MATERIAL

REV.	ISSUE DATE	DESCRIPTION	PREPARED	CHECKED	APPROVED
R1	07.13.2024	ISSUED FOR APPROVAL (IFA)	D.SH.	M.O.	A.M.
R0	06.27.2024	ISSUED FOR APPROVAL (IFA)	D.SH.	M.O.	A.M.

CLIENT

CONSULTING ENGINEER

PROJECT:

DRAWING TITLE:  
**BUNDLE DETAIL DRAWING FOR  
 CHILLER (EVAPORATOR) (1/2)**

DRAWING NO.	REV.	SIZE	SCALE	SHEET
EIO27-HSE-VD-ME-DWG-008	R1	A3	NTC	3 of 8







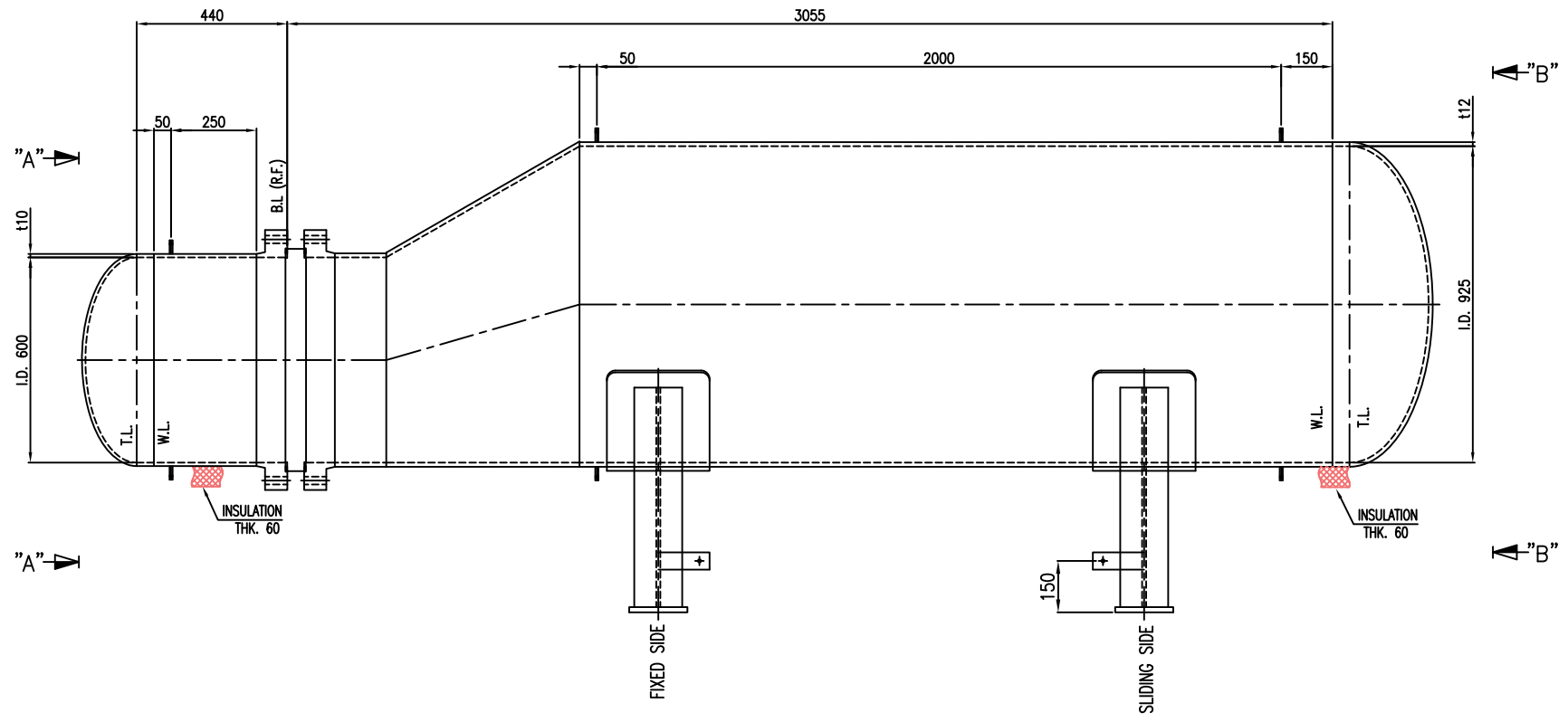

ELEVATION VIEW

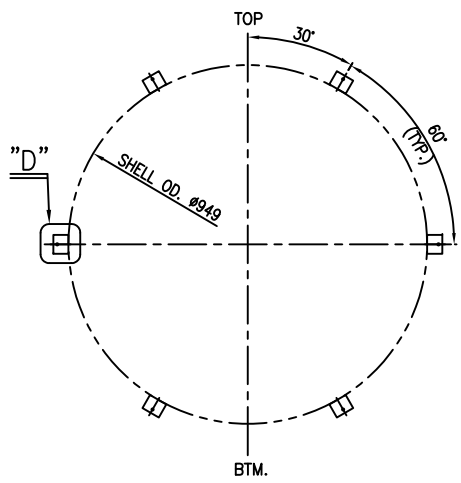

VIEW "B"- "B"

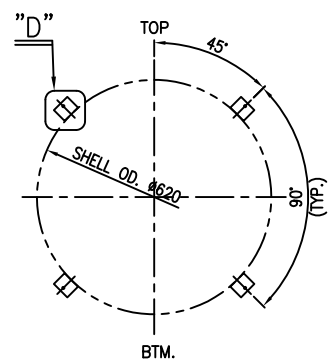

VIEW "A"- "A"

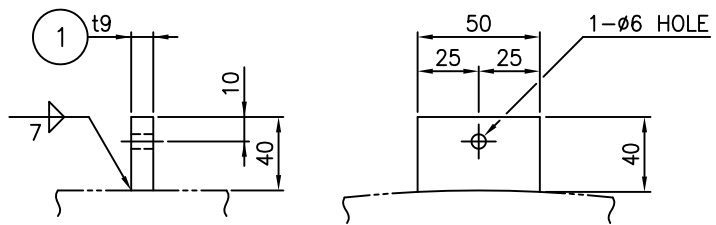

DETAIL "D"

**NOTES**  
1. UNLESS OTHERWISE NOTED ALL DIMENSIONS ARE IN MILLIMETERS.

\* FOR ONE SET

PART NO.	PART NAME	MATERIAL	REGULAR QUANTITY	SPARE QUANTITY	SPECIFICATION	REMARK
1	INSUL. SUPT CLIP	SAS16-70N	16		19 x 40 x 50	

**BILL OF MATERIAL**

REV.	ISSUE DATE	DESCRIPTION	PREPARED	CHECKED	APPROVED
R0	06.27.2024	ISSUED FOR APPROVAL (IFA)	D.SH.	M.O.	A.M.

CLIENT

CONSULTING ENGINEER

PROJECT:

DRAWING TITLE:  
**INSULATION CLIP DRAWING FOR  
CHILLER (EVAPORATOR)**

DRAWING NO.	REV.	SIZE	SCALE	SHEET
EI027-HSE-VD-ME-DWG-008	R0	A3	NTC	7 of 8

